



Address 100 Barr Harbor Drive
PO Box C700
W. Conshohocken, PA
19428-2959 | USA

Phone 610.832.9500
Fax 610.832.9666
Web www.astm.org

Committee D02 on PETROLEUM PRODUCTS AND LUBRICANTS

Chairman: KENNETH O. HENDERSON, Cannon Instrument Co., 2139 High Tech Road, State College, PA 16803, (814) 353-8000, Fax: (814) 353-8007, e-mail: kenohenderson@worldnet.att.net
First Vice-Chairman: BEN R. BONAZZA, 3457 WOODVALLEY DRIVE, LAPEER, MI 48446 (810) 664-6769 e-mail: bbonazza@charter.net
Second Vice-Chairman: JANET L. LANE, ExxonMobil Research & Engrg., 600 Billingsport Rd, Paulsboro, NJ 08066-0480 (856) 224-3302, Fax: (856) 224-3616, e-mail: janet.l.lane@exxonmobil.com
First Secretary: RALPH A. CHERRILLO, Shell Global Solutions (US) Inc., Westhollow Tech Ctr., 3333 Highway 6 South, Houston, TX 77082 (281) 544-8789, Fax: (281) 544-8150, e-mail: ralph.cherrillo@shell.com
Second Secretary: MICHAEL A. COLLIER, Petroleum Analyzer Co. LP, PO Box 206, Wilmington, IL 60481, (815) 458-0216, Fax: (815) 458-0217, e-mail: Michael.collier@pacpl.com
Staff Manager: DAVID R. BRADLEY, (610) 832-9681, Fax: (610) 832-9668, e-mail: dbradley@astm.org

June 12, 2009

Reply to:
Rick Graziano
The Lubrizol Corporation
29400 Lakeland Blvd.
Wickliffe, OH 44092
(440) 347-2058
(440) 347-2878 (FAX)
ricki.graziano@lubrizol.com

ASTM D02.B0.03 L-60-1 Surveillance Panel
Members and Guests:

Attached for your review and comment are the unconfirmed minutes of the May 13, 2009 L-60-1 Surveillance Panel meetings held at the U.S. Army TACOM facility in Warren, MI. They have been updated, as of 6/12/09, to reflect the approval of the L-60-1 Gear Case Assembly drawings which were corrected as directed. Please direct any corrections or comments to my attention.

Sincerely,

Rick Graziano
Chairman
L-60-1 Surveillance Panel

Attachments

**Report of Meeting
L-60-1 Surveillance Panel
TACOM- Main Conference Room #210, Warren, MI
May 13, 2009**

Sign-in/Review of Membership: The meeting was called to order at 9:00 a.m. The sign-in sheet is included as **Attachment # 1**. A review of membership was performed. Membership list to be updated as Allen Comfort from RDTA-PD/MS10 US Army has replaced Rachel Augusti as SP voting member. '6' voting members present.

Review of Meeting Agenda

The meeting agenda is included as **attachment # 2**.

Approval of minutes

- February 11, 2009 L-60-1 Surveillance Panel Meeting

Motion 1 ⇒ -Motion by Mr. Smith/Second Mr. Koglin, minutes approved as written unanimously with no abstentions. Vote 6-0-0.

Summary of Meeting Discussions

Rating experiment planned for summer workshop

See PowerPoint attachment (new rating experiment procedure) for details as **attachment # 3**.

The next Rater workshop is scheduled at Lubrizol the week of July 20th. The new rating experiment procedure will be used at this workshop.

Mr. Lind – each rater should use this procedure at a workshop at least twice.

The experiment can take up to 3-4 workshops before every rater has used the new procedure.

D5704, Figure A2.1 in Section 6.1.15 assembly drawing

See PowerPoint attachment for details as **attachment # 3**.

Rick Graziano reviewed the current drawing and the updated drawing.

Updated drawing needs to be corrected. The small gear is identified as '26' in drawing and should be changed to "31".

The panel would like to see the part numbers referenced in the drawing (V-ring).

Overall the panel likes the updated drawing. Mr. Gropp asked if we should take a motion to approve the updated drawings.

Motion 2 ⇒ - Motion by Mr. Koglin /Second by Mr. Koehler, to accept updated drawing with editorial change. Vote 6-0-0.

Chairman's comments: The drawing has been updated to include the corrections discussed at the meeting; they have been reviewed and have been approved as of 6/12/09.

New Business

None

Motion 3 ⇒ Motion for meeting adjournment by Mr. Lind/Second by Mr. Koehler. The meeting was adjourned at 9:30a.m.

Respectfully submitted,

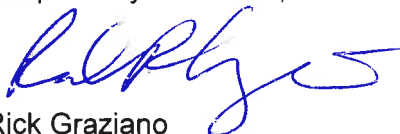

Rick Graziano
L-60-1 Surveillance Panel Chairman

ASTM L-60-1 Surveillance Panel Membership/Mailing List

Meeting Date: February 11, 2009

Initials*	Name	Voting Status	Company Name & Address	Phone & Fax & E-Mail
	Anderson, Greg	Non-voting	Falex Corporation 1020 Airpark Drive Sugar Grove, Illinois 60554-9585	Phone: 630-556-3669 Fax: 630-556-3679 E-Mail:
	Aguetti, Rachel	voting	AMSTRO-TAR-D/210 6501 E.11 Mile Rd Warren, MI 48397-5000	Phone: 586-574-4222 Fax: 586-574-4244 E-Mail: rachel.jackman@us.army.mil
	Bartlett, Don	Non-voting	The Lubrizol Corporation 29400 Lakeland Boulevard Wickliffe, Ohio 44092	Phone: 440-347-2388 Fax: 440-347-2878 E-Mail: dtb@lubrizol.com
	Bell, Don	Non-voting	Afton Chemical Corporation 500 Spring Street Richmond, Virginia 23219	Phone: 804-788-6332 Fax: 804-788-6342 E-Mail: Don.Bell@aftonchemical.com
	Bryson, Tom	Voting	Mack Trucks 13302 Pennsylvania Avenue Hagerstown, Maryland 21740	Phone: 301-790-5454 Fax: 301-790-6744 E-Mail: tom.bryson@macktrucks.com
	Chambers, Harold	Non-voting	43945 Merrill Rd. Sterling Hts., MI 48314	Phone: (586) 770-4694 Fax: E-Mail: haroldchambers@gmail.com

Attachment /
Page 147
Reference L-60-1
5-13-09

* Initial to indicate attendance at subject meeting

ASTM L-60-1 Surveillance Panel Membership/Mailing List

Meeting Date: February 11, 2009

Initials*	Name	Voting Status	Company Name & Address	Phone & Fax & E-Mail
A.C.	Comfort, Allen	Non-voting Voting	AMSTA-TR-D/210 (Allen Comfort) U S Army Tank, Automotive, and Armament Command Warren, Michigan 48397-5000	Phone: 586-574-4225 Fax: 586-574-4244 E-Mail: comfarte@castaeem-ammc.mil <i>allen.comfort@us.army.</i>
	Purnell, Keith	Non-voting	Performance Review Institute 161 Thornhill Road Warrendale, Pennsylvania 15086-7527	Phone: 724-772-1616 X8182 Fax: 724-772-1699 E-Mail: kpurnell@sae.org
	Duckstein, Bob <i>Retired</i>	Non-voting	Parc Technical Services Inc. 100 William Pitt Way Pittsburgh, Pennsylvania 15238	Phone: 412-826-5115 Fax: 412-826-5443 E-Mail: rhd@usaor.net
	Eliot, Stephen W.	Non-Voting	Commercial Vehicle Lubricants ExxonMobil Lubricants & Specialties Leesburg, Virginia	Phone: 703-669-9916 Fax: 703-669-9917 E-Mail: stephen.w.eliot@exxonmobil.com
	Farber, Frank	Non-voting	ASTM Test Monitoring Center 6555 Penn Avenue Pittsburgh, Pennsylvania 15206	Phone: 412-365-1030 Fax: 412-365-1047 E-Mail: fmf@astmtmc.cmu.edu
	Fett, Gregory	Voting	DANA, P.O. Box 955 Toledo, Ohio 43697 3939 Technology Drive Maumee, Ohio 43537	Phone: (419) 887-3296 Fax: E-Mail: greg.fett@dana.com

Attachment 1
Page 2 of 7
Reference L60-1
5-13-09

* Initial to indicate attendance at subject meeting

ASTM L-60-1 Surveillance Panel Membership/Mailing List

Meeting Date: February 11, 2009



Initials*	Name	Voting Status	Company Name & Address	Phone & Fax & E-Mail
	Graziano, Rick	Voting	The Lubrizol Corporation 29400 Lakeland Boulevard Wickliffe, Ohio 44092	Phone: 440-347-2058 Fax: 440-347-2878 E-Mail: ricki.graziano@lubrizol.com
<i>RG</i>	Greene, Galen	Non-voting	The Lubrizol Corporation 29400 Lakeland Boulevard Wickliffe, Ohio 44092	Phone: 440-347-2394 Fax: 440-347-2878 E-Mail: galen.greene@lubrizol.com
<i>JG</i>	Gropp, Jerry	Non-voting	The Lubrizol Corporation 29400 Lakeland Boulevard Wickliffe, Ohio 44092	Phone: 440-347-1223 Fax: 440-347-1555 E-Mail: jerrold.gropp@lubrizol.com
	Guzikowski, Joe	Non-voting	DANA P.O. Box 955 Toledo, Ohio 43697 3939 Technology Drive Maumee, Ohio 43537	Phone: 419-887-3425 Fax: E-Mail: joe.guzikowski@dana.com
	Haire, Mike	Voting	Chevron 100 Chevron Way Richmond, California, 94802	Phone: 510-242-2740 Fax: 804-788-6358 E-Mail: mhaire@chevron.com
<i>SH</i>	Higuchi, Sam	Non-voting	Afton Chemical Corporation 500 Spring Street Richmond, Virginia 23219	Phone: 804-788-5375 Fax: 804-788-6358 E-Mail: samuel.higuchi@aftonchemical.com

Attachment 1
Page 367
Reference L-60-1
5-13-09

* Initial to indicate attendance at subject meeting

ASTM L-60-1 Surveillance Panel Membership/Mailing List

Meeting Date: February 11, 2009

Initials*	Name	Voting Status	Company Name & Address	Phone & Fax & E-Mail
	Huron, John	Non-voting	Chevron Oronite 4502 Centerview Drive, Suite 210 San Antonio, Texas 78228	Phone: 210-731-5609 Fax: 210-731-5689 E-Mail: HURO@ChevronTexaco.com
	Kanga, Percy R.	Non-Voting	Commercial Vehicle, Marine & Gas Engine Lubricants ExxonMobil Research & Engineering 600 Billingsport Road Paulsboro, NJ. 08066	Phone: 856-224-2094 Fax: 856-224-3613 E-Mail: percy.r.kanga@exxonmobil.com
	Koehler, Brian	Voting	Southwest Research Institute Road Bldg.209 San Antonio, TX. 78238-5166	Phone: (210) 522-3588 Fax: (210) 684-7523 E-Mail: bkoehler@swri.org
	Koglin, Cory	Voting	Afton Chemical Corporation 500 Spring Street Richmond, Virginia 23219	Phone: 804-788-5305 Fax: 804-788-6358 E-Mail: cory.koglin@afonchemical.com
	Lind, Don	Voting	ASTM Test Monitoring Center 6555 Penn Avenue Pittsburgh, Pennsylvania 15206	Phone: 412-365-1034 Fax: 412-365-1047 E-Mail: dml@astmtmc.cmu.edu
	Marougy, Thelma	Voting	Eaton Corporation 26201 Northwestern Highway Southfield, Michigan 48037	Phone: 248-354-6985 Fax: 248-354-2739 E-Mail: thelmaemarougy@eaton.com

Attachment 1
 Page 4 of 7
 Reference L-60-1
 5-13-09

* Initial to indicate attendance at subject meeting

ASTM L-60-1 Surveillance Panel Membership/Mailing List

Meeting Date: February 11, 2009

Initials*	Name	Voting Status	Company Name & Address	Phone & Fax & E-Mail
	Marty, Steve	Non-voting	Southwest Research Institute 6220 Culebra Road San Antonio, Texas 78238	Phone: 210-522-5929 Fax: 210-680-1777 E-Mail: smarty@swri.edu
	McGlone, Bruce	Voting	AtvinMeritor 2135 West Maple Troy, Michigan 48084	Phone: 248-435-9929 Fax: 248-435-1411 E-Mail: mcglonbf@meritorauto.com
	Reitmann, Kevin	Non-voting	PerkinElmer Fluid Sciences 5404 Bandera Road San Antonio, Texas 78238	Phone: 210-706-1546 Fax: 210-523-4614 E-Mail: Kevin.Reitmann@perkinelmer.com
	Shah, Rajesh	Non-voting	Koehler Instrument Company 1595 Sycamore Avenue Bohemia, New York 11716	Phone: 516-589-3800 Fax: 516-589-3815 E-Mail:
	Smith, Dale	Voting Non-voting	Parc Technical Services Inc. 100 William Pitt Way Pittsburgh, Pennsylvania 15238	Phone: 412-423-1120 X 403 Fax: 412-826-5444 E-Mail: Dale.Smith@intertek.com
	Sullivan, Bill	Non-voting	WTSullivan, Inc. 5 Scheiber Drive Brick, New Jersey 08723	Phone: 908-930-3512 Fax: 267-220-7750 E-Mail: wtsullivan@comcast.net

Attachment 1
Page 5 of 7
Reference L-60-1
5-13-09

* Initial to indicate attendance at subject meeting

ASTM L-60-1 Surveillance Panel Membership/Mailing List

Meeting Date: February 11, 2009

Initials*	Name	Voting Status	Company Name & Address	Phone & Fax & E-Mail
	Ved. shintan	Non-voting	Ford- Trans & Driveline Lubrication 35500 Plymouth Rd. Livonia, MI 48150	Phone: 313-805-9695 Fax: 267-220-7750 E-Mail: cved@ford.com
	Vettel, Paula	Voting	D. A. Stuart Company 4580 Weaver Parkway Warrenville, Illinois 60555	Phone: 630-393-8859 Fax: 630-393-8577 E-Mail: pvettel@dastuart.net
	Villahermosa, Luis	Non-voting	AMSTA-TR-D/210 (Luis Villahermosa) U S Army Tank, Automotive, and Armament Command Warren, Michigan 48397-5000	Phone: 586-574-4207 Fax: 586-574-4123 E-Mail: villahel@cc.tacom.army.mil
	Whitton, Claire	Non-voting	Ethyl Research Center 500 Spring Street P. O. Box 2158 Richmond, Virginia 23218-2158	Phone: 804-788-5052 Fax: 804-788-6243 E-Mail: Claire_Whitton@ethyl.com
	Zakarian, Jack	Non-voting	Chevron Products Company 100 Chevron Way Richmond, California 94802-0627	Phone: 510-242-3595 Fax: 510-242-3758 E-Mail: jaza@chevron.com
	Mr. Wen Tung Lu	Non-voting	Research Institute of Petroleum (RIPP) No. 18 Xue Yuan Rd. PO Box 914-19 Beijing, China	Phone: 011-86-10-8236-8182 Fax: 011-86-139-1117-7663 E-Mail: luwt@ripp-sinopec.com

Attachment 1
 Page 667
 Reference L-60-1
 5-13-09

* Initial to indicate attendance at subject meeting

ASTM L-60-1 Surveillance Panel Membership/Mailing List

Meeting Date: February 11, 2009

Initials*	Name	Voting Status	Company Name & Address	Phone & Fax & E-Mail
	Mr. HaiQing Song	Non-voting	Research Institute of Petroleum (RIPP) No. 18 Xue Yuan Rd. PO Box 914-19 Beijing, China	Phone: 011-86-10-8236-8743 Fax: 011-86-10-8231-1290 E-Mail: songhq@ripp-sinopec.com
	Mr. Jing Chun Xie	Non-voting	Engine Test Lab Lanzhou Lube Oil R&D Institute No. 369 Yu Men St. XiGu Dist. Lanzhou 730060 GanSu Prov. China	Phone: 011-86-931-793-3713 Fax: 011-86-139-9319-2560 E-Mail: xjc@lubertdi.com.cn

Juan Pett Non

General Motors

248-800-6448

Pontiac Powertrain

Juan.Pett@gm.com

John Dharte Non

AAM

248-299-6478

Dhartej@aam.com

Bill Kearney Non

AFTON CHEMICAL

248-350-0640

bill.kearney@afonchemical.com

BRIDGET BROSANAN Non

AMSTRD-TAR/D 210

586.574.4221

bridget.brosnan@us.army.mil

Attachment	1
Page	767
Reference	L-60-1
	5-13-09

* Initial to indicate attendance at subject meeting

L-60-1 Surveillance Panel

May 13, 2009

9:00 a.m. – 10:00 a.m.

TACOM- Main Conference Room #210 – Warren, MI

Agenda

- I. Call to order
- II. Membership and agenda review
- III. Approval of meeting minutes
 - February 11, 2009
- IV. Rating experiment planned for winter rating workshop
 - TMC to update panel on upcoming Rater Workshop
- V. Updating figure A2.1 of the D5704
 - RPG to discuss update to figure A2.1
- VI. New Business
- VII. Adjournment

Attachment	2
Page	141
Reference	L-60-1
	5-13-09

L-60-1 Surveillance Panel Meeting
May 13, 2009
9:00 a.m. – 10:00 a.m.
TACOM- Main Conference Room #210 – Warren, MI

L-60-1 Surveillance Panel
May 13, 2009
9:00 a.m. – 10:00 a.m.
TACOM- Main Conference Room #210– Warren, MI

Agenda

- I. Call to Order
- II. Agenda and Membership Review
- III. Approval of Meeting Minutes
 - February 11, 2009
- IV. Rating Experiment - Rating Workshop
 - TMC to update panel on upcoming rater workshop
- V. Updating figure A2.1 of the D5704
- VI. New Business
- VII. Adjournment

2

Attachment	<u>3</u>
Page	<u>147</u>
Reference	<u>L-60-1</u> <u>S-13-09</u>

L-60-1 Surveillance Panel Voting Members

Rick Graziano	The Lubrizol Corporation (Chairman)
Rachel Agusti	AMSTA-TR-D/210 US Army
Tom Bryson	Volvo Power Train Corporation
Greg Fett	Dana Corporation
Mike Haire	Chevron Global Lubricants
Brian Koehler	Southwest Research Institute
Cory Koglin	Afton Chemical Company
Don Lind	ASTM Test Monitoring Center
Thelma Marougy	Eaton Corporation
Bruce McGlone	ArvinMeritor Materials Engineering
Paula Vettel	D.A. Stuart Company

Total 11 Voting Members

3

L-60-1 Surveillance Panel

May 13, 2009

9:00 a.m. – 10:00 a.m.

TACOM- Main Conference Room – Warren, MI

Agenda

- I. Call to Order
- II. Agenda and Membership Review
- III. **Approval of Meeting Minutes**
 - February 11, 2009
- IV. Rating Experiment - Rating Workshop
 - TMC to update panel on upcoming rater workshop
- V. Updating figure A2.1 of the D5704
- VI. New Business
- VII. Adjournment

4

Attachment	<u>3</u>
Page	<u>247</u>
Reference	<u>L-60-1</u>
	<u>5-13-09</u>

L-60-1 Surveillance Panel
May 13, 2009
9:00 a.m. – 10:00 a.m.
TACOM- Main Conference Room #210– Warren, MI

Agenda

- I. Call to Order
- II. Agenda and Membership Review
- III. Approval of Meeting Minutes
 - February 11, 2009
- IV. **Rating Experiment - Rating Workshop**
 - TMC to update panel on upcoming rater workshop
- V. Updating figure A2.1 of the D5704
- VI. New Business
- VII. Adjournment

5

Rating Experiment Planned for Winter Rating Workshop

- Purpose of experiment is to test a refinement to the L-60-1 ACV rating procedure
- The process was initially developed at the summer workshop
- Surveillance Panel approved a motion on 8/13/08 to conduct a round robin type evaluation by cycling reference gears from lab to lab
- All raters are encouraged to participate but only the values generated by the high volume raters will be used to gauge the effectiveness

6

Attachment	<u>3</u>
Page	<u>347</u>
Reference	<u>L-60-1</u>
	<u>S-13-08</u>

Rating Experiment Planned for Winter Rating Workshop

- Lubrizol drafted the rating procedure and a 9/25/08 SP teleconference was held to discuss details
- The major improvement involves orienting the gear at a fixed position relative to the light making any adjustments from a horizontal position while rating (see next slide)
- Teleconference Attendees:
 - TMC - Don Lind
 - PARC - Ralph Kozlowski
 - SwRI - Art Sanchez, Jesse Rodriguez, Frank Lopez
 - Afton - Pat Adams, Cory Koglin, Wes Stocks
 - Lubrizol - Don Bartlett, Pete Radonich, Rick Graziano, Galen Greene, Chris Schenkenberger
- For the purpose of making sure the experiment is run properly, it was decided to conduct the work at the winter rating workshop

7

Rating Experiment Planned for Winter Rating Workshop

L-60 Rating Procedure

1. Handle the gears at the gear teeth lands to avoid any contact of the rated area.
2. Use a cool white type fluorescent 4500 K color temperature light with a minimum illumination level of 200 foot-candles for rating gears.
3. Place one white 8 1/2" X 11" U.S. letter size paper on the base of the rating surface.
4. Wipe a 3/4 inch wide area across the diameter of the face of the gear along the keyway. Wipe the gear five times in the same direction.
5. Place the gear on the clear plastic holder with the keyway vertical, front side up. Do not tilt or adjust the gear from the flat orientation while rating.
6. Position the light 8 ± 0.5 inches level above the gear with the near edge of the light projecting downward directly over the center-bore of the gear.
7. Rate the bottom half of the gear looking directly down on the gear, from above the near edge of the light. Do not rate the gear teeth or the spacer bushing contact area.
8. Rotate the gear 180 degrees and rate the other half of the gear.
9. Turn the gear over and repeat the rating procedure for the back side.
10. Use any of the three Rating Scales (A, B or C) for Non-Rubbing Parts in CRC Manual No. 20 to determine the varnish rating.
11. Do not use new test parts, such as a gear or the washer nut area of the test gear as a 10.0 rating reference point.
12. Repeat both large and small gear with the same procedure.

8

Attachment	3
Page	4/6
Reference	L60-1
	5-13-05

L-60-1 Surveillance Panel
 May 13, 2009
 9:00 a.m. – 10:00 a.m.
 TACOM- Main Conference Room #210 – Warren, MI

Agenda

- I. Call to Order
- II. Agenda and Membership Review
- III. Approval of Meeting Minutes
 - February 11, 2009
- IV. Rating Experiment - Rating Workshop
 - TMC to update panel on upcoming rater workshop
- V. **Updating figure A2.1 of the D5704**
- VI. New Business
- VII. Adjournment

9

D5704, Figure A2.1 – Exploded View of Gear Case

A2.1 EXPLODED VIEW OF GEAR CASE ASSEMBLY

A2.1 Gear Case Assembly Parts List (see Fig. A2.1):

(1) Lower Shaft (Shaft) Inert Thread	(51) Shimless Steel Ball	(37) Bearing Housing
(2) Upper Shaft (Shaft) Inert Thread	(52) Shimless Steel-Copper Washer	(38) Ball Cap, 4.0 in by 4.0 in
(3) Gear Case Support	(53) Ball Pin	(39) Ball Cap Nut Cover
(4) Pin (Pin) Housing	(54) Cageless Washer	(40) Shimless Steel Cover
(5) Seal Sleeve, CH 0002	(55) Shimless Steel Flat Washer, 7/8 in	(41) Gear Housing Ball (Right-Hand Thread)
(6) Spring Washer	(56) Shimless Steel Flat Washer, 1/2 in by 1/2 in	(42) Gear Housing Ball (Left-Hand Thread)
(7) Gear Case	(57) Cotter Pin	(43) O-Ring, 1/8 in ID
(8) Cap Screw, 7/8 in-20 by 1/2 in	(58) Upper Spring Washer	(44) Gear Case Cover Plate
(9) Seal Tube	(59) Lower Spring Washer	(45) Seal Washer, 2.0 in
(10) O-Ring, 2.125 in ID	(60) Housing Cover	(46) Cap Screw, 1/2 in by 4.0 in
(11) Seal, CR0002	(61) Shimless Steel Cap Screw, 1/2-20 by 1/2 in	(47) Seal Tube Gasket
(12) Seal Pin	(62) Shimless Steel Flat Washer, 1/2 in	
(13) Shimless Steel Flat Washer, 1/2 in	(63) Ball Housing	

• V-ring location...

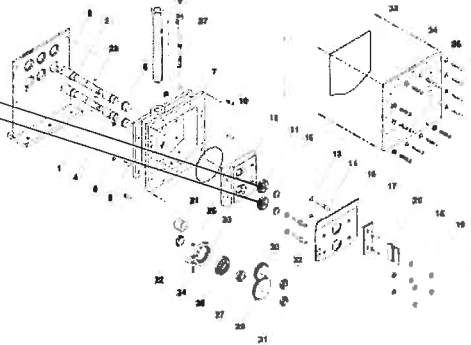

FIG. A2.1 Exploded View of Gear Case Assembly

10

Attachment 3
 Page 517
 Reference L-60-1
5-13-09

A2. EXPLODED VIEW OF GEAR CASE ASSEMBLY

A2.1 Gear Case Assembly Parts List (see Fig. A2.1)

- | | | |
|------------------------------------|--|--|
| 1) Lower Shaft (Right-Hand Thread) | 14) Stainless Steel Flat Washer 5/16" x 3/4" | 27) 8-14 Tef Bearing |
| 2) Upper Shaft (Left-Hand Thread) | 15) Stainless Steel #3 | 28) Gear Bushing |
| 3) Gear Case Support | 16) Stainless Steel External Retainer | 29) 2-11 by 1/8" x 3/8" Pin |
| 4) Gear Case Bushing | 17) Baffle Plate | 30) Cap-Screw 10-32 by 3/4" |
| 5) Gear Case (99024) | 18) Catalyst Housing | 31) Gear Retaining Nut (Right-Hand Thread) |
| 6) Spacer Washer | 19) Stainless Steel Flat Washer 1/16" x 1/4" | 32) Gear Retaining Nut (Left-Hand Thread) |
| 7) Gear Case | 20) Stainless Steel Hex Nut 5/16" x 1/8" | 33) O-Ring 1.5" O.D. |
| 8) Cap Screw 5/16" x 24 by 3/4" | 21) Catalyst | 34) Gear Case Cover-Right |
| 9) Vent Tube | 22) Upper Spacer Bushing | 35) 10-24 Washer 2 1/2" |
| 10) O-Ring 1 1/2" x 1/32" | 23) Lower Spacer Bushing | 36) Cap Screw 10-32 by 3/4" |
| 11) O-Ring 1.58" | 24) Gear Case | 37) Vent Tube Baffle |
| 12) Seal Plate | 25) Stainless Steel Cap Screw 10-32 by 3/4" | |
| 13) V-Ring | 26) Stainless Steel Hex Nut #10-32 | |

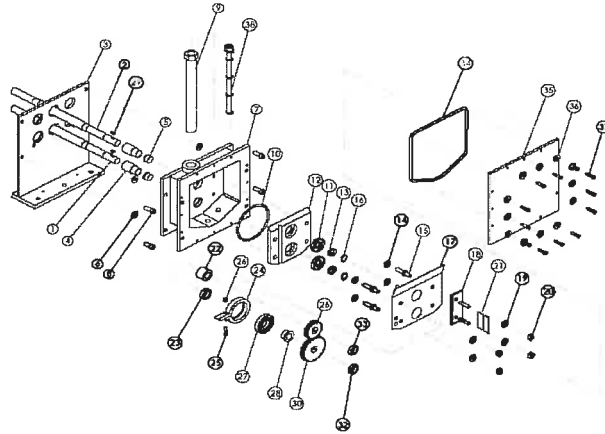

11

D 5704 - 08

A2. EXPLODED VIEW OF GEAR CASE ASSEMBLY

A2.1 Gear Case Assembly Parts List (see Fig. A2.1)

- | | | |
|------------------------------------|--|--|
| 1) Lower Shaft (Right-Hand Thread) | 14) Stainless Steel Flat Washer 5/16" x 3/4" | 27) Test Bearing (8-14) |
| 2) Upper Shaft (Left-Hand Thread) | 15) Stainless Steel External Retainer | 28) Gear Bushing |
| 3) Gear Case Support | 16) Baffle Plate | 29) 2-11 by 1/8" x 3/8" Pin |
| 4) Gear Case Bushing | 17) Catalyst Housing | 30) Cap-Screw 10-32 by 3/4" |
| 5) Gear Case (99024) | 18) Stainless Steel Flat Washer 1/16" x 1/4" | 31) Gear Retaining Nut (Right-Hand Thread) |
| 6) Spacer Washer | 19) Stainless Steel Hex Nut 5/16" x 1/8" | 32) Gear Retaining Nut (Left-Hand Thread) |
| 7) Gear Case | 20) Catalyst | 33) O-Ring 1.5" O.D. |
| 8) Cap Screw 5/16" x 24 by 3/4" | 21) Upper Spacer Bushing | 34) Gear Case Cover-Right |
| 9) Vent Tube | 22) Lower Spacer Bushing | 35) 10-24 Washer 2 1/2" |
| 10) O-Ring 1 1/2" x 1/32" | 23) Gear Case | 36) Cap Screw 10-32 by 3/4" |
| 11) O-Ring 1.58" | 24) Stainless Steel Cap Screw 10-32 x 3/4" | 37) Vent Tube Baffle |
| 12) Seal Plate | 25) Stainless Steel Hex Nut #10-32 | |
| 13) V-Ring (99114) | | |

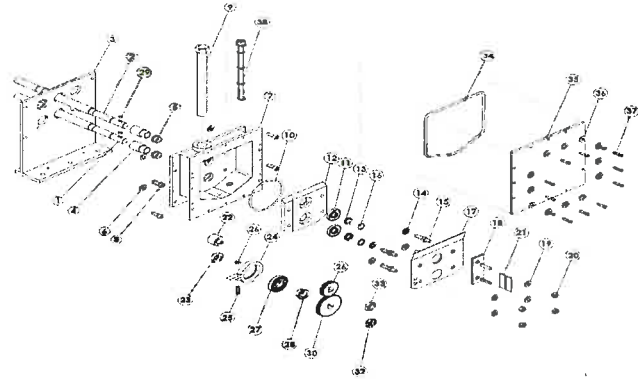

FIG. A2.1 Exploded View of Gear Case Assembly

12

Attachment 3
 Page 667
 Reference L-60-1
5-13-09

L-60-1 Surveillance Panel
May 13, 2009
9:00 a.m. – 10:00 a.m.
TACOM- Main Conference Room #210 – Warren, MI

Agenda

- I. Call to Order
- II. Agenda and Membership Review
- III. Approval of Meeting Minutes
 - February 11, 2009
- IV. Rating Experiment - Rating Workshop
 - TMC to update panel on upcoming later workshop
- V. Updating figure A2.1 of the D5704
- VI. **New Business**
- VII. Adjournment

13

Attachment	<u>3</u>
Page	<u>267</u>
Reference	<u>L-60-1</u>
	<u>5-13-09</u>