

STANDARD TEST METHOD FOR EVALUATION OF THE LOAD CARRYING PROPERTIES OF LUBRICANTS USED FOR FINAL DRIVE AXLES, UNDER CONDITIONS OF HIGH SPEED AND SHOCK LOADING¹

*This procedure has been updated with Information Letter 07-1 on May 9, 2007
This includes revised drawings with y axis changes, hold for next information letter.*

1. Scope

1.1 This test method is commonly referred to as the L-42 test². This test method is used for determining the anti-scoring properties of final drive axle lubricating oils when subjected to high-speed and shock conditions.

1.2 The values stated in foot-pound units are to be regarded as standard; e.g. torque is stated in foot-pound units, the values for temperature are stated in degrees Fahrenheit, and the test lubricant sample volume is stated in pints. The values given in parentheses are mathematical conversions to SI units that are provided for information purposes only, and are not considered standard. SI units are provided for all parameters except where there is no direct equivalent such as the units for screw threads, national pipe threads/diameters, and tubing size.

1.3 *This procedure does not purport to address all of the safety concerns, if any, associated with its use. It is the responsibility of the user of this procedure to establish appropriate safety and health practices and determine the applicability of regulatory limitations prior to use. Specific hazard information is given in Sections 4 and 7.*

2. Referenced Documents

2.1 ASTM Standards³

D 235 Specification for Mineral Spirits (Petroleum Spirits) (Hydrocarbon Dry Cleaning Solvent)

E 29 Practice for Using Significant Digits in Test Data to Determine Conformance with Specifications

2.2 Society of Automotive Engineers Standards⁴

SAE J308-Information Report on Axle and Manual Transmission Lubricants

SAE J2360 Lubricating Oil, Gear (Metric) Military Use

2.3 Other Documents:

Coordinating Research Council (CRC) Rating Manual No. 21⁵

Dana Model 44 Maintenance Manual (See Section 8)⁶

3. Terminology

3.1 Definitions of Terms Specific to This Procedure:

3.1.1 Scoring, n - On the ring and the pinion gear teeth, the displacement of metal by local momentary welding from the gear tooth, resulting in the development of a matt, or frosted dull surface (CRC Manual 21)⁵.

3.1.2 Drive Side, n - The concave side of the pinion and the convex side of the ring gear which are in contact during acceleration in a forward gear (CRC Manual 21)⁵.

3.1.3 Coast Side, n - The convex side of the pinion and the concave side of the ring gear which are in contact during deceleration in a forward gear (CRC Manual 21)⁵.

4. Summary of Test Method

4.1 Charge a specially prepared light duty hypoid rear axle (Dana Model 44 ASTM Part No. 044AA100-1)⁶ with the lubricant sample to be tested. Mount the axle between two load absorbing dynamometers which are driven with a V-8 gasoline engine through a manual transmission.

4.2 Condition the test axle with light loads at different speed, torque and temperature conditions on both the drive and coast sides of the gears. (**Warning** - High-Speed rotating Equipment, Electrical Shock, High-Temperature Surfaces.). After conditioning, subject the test axle to high speed and shock loadings at higher temperatures.

4.3 Rate the drive and coast side of the pinion and ring gears at the end of test (EOT) for scoring distress.

5. Significance and Use

5.1 Final drive axles are often subjected to severe service where they encounter high speed shock load conditions, characterized by sudden accelerations and decelerations. This severe service can lead to scoring distress on the ring gear and pinion surface. This test method measures anti-scoring properties of final drive lubricants.

5.2 This test method is used or referred to in the following documents:

5.2.1 American Petroleum Institute (API) Publication 1560- Lubricant Service Designations for Automotive Manual Transmissions, Manual Transaxles, and Axles⁷.

5.2.2 SAE J308-Information Report on Axle and Manual Transmission Lubricants⁴.

5.2.3 SAE J2360 – Lubricating Oil, Gear Multipurpose (Metric) Military Use⁴.

6. Apparatus

6.1 This test method provides a description of essential apparatus features, including mandatory equipment type and performance specifications where established

6.2 *Test Axle* - The test unit consists of a Dana model 44 rear axle, 45 to 11 (4.09) ratio, and uncoated gears. (Dana ASTM part number 044AA100-1⁶. See 10.1.)

6.3 *Cover Plate*: Modify the rear cover plate of the test unit to provide an inspection port and thermocouple fitting. Locate the thermocouple fitting by using the locating fixture shown in Figure A2.1. An optional ¼ in NPT (National Pipe Thread) drain fitting may be added.

6.4 *Axle Shaft Assemble*: Use a Ford Axle shaft assembly, (Dana Part No. 26762-14X) or equivalent with this test method.

6.5 *Hinge Plate Stand Assembly*: Mount and secure the test unit in place on the hinge plate assembly, see. A2.6, A2.7, A2.8, and A2.9.

6.6 *Temperature Control System*: The temperature control apparatus consists of a thermocouple, a temperature recording system, temperature controller and a cooling system that is able to maintain lubricant temperature at specified conditions.

6.6.1 *Thermocouple*: Install the thermocouple such that the thermocouple tip is flush with the cover plate lip by placing the cover plate face on a flat surface and inserting the thermocouple into the cover plate until the thermocouple tip is flush with the flat surface. For recording and control of the test lubricant temperature, use a 1/8 in. (3.2 mm) diameter J or K type closed tip style thermocouple.

6.6.2 *Temperature Recording System*: Throughout the test, ensure the temperature recording system records the temperature of the test oil at a minimum frequency of 1 Hz.

6.6.3 *Temperature Controller*: Proportional-Integral-Derivative (PID) type; percent output adjustable.

6.6.4 *Axle Cooling*—Use three spray nozzles to distribute water over the cover plate and axle housing as shown in Fig. A2.2. Actuate the water control valve by the temperature PID control system.

6.6.4.1 Depending on how the system is plumbed, use spray nozzles⁸ in any combination of the following part numbers: Straight Male NPT (Part No. 3/8GG-SS22), 90° Male NPT (Part No. 3/8GGA-SS22), Straight Female NPT (Part No. 3/8G-SS22), and 90° Female NPT (Part No. 3/8GA-SS22).

6.6.4.2 Use a single control valve to control the cooling water supply. The control shall be a ½ in. two-way, C linear trim, air to close, Research Control valve. Use a single PID loop to maintain the axle lubricant temperature control for both the Standard and Canadian version test. A separate PID loop control for each version is not permitted. See Annex A1.

6.6.4.3 Use *only* 3/8 or ½ in. line material to the spray nozzles.

6.6.4.4 Use a minimum supply water pressure of 25 psig (172 kPa) to the control valve.

6.6.4.5 Use an axle containment box as shown in Fig. A2.10. The purpose is to contain water.

6.6.4.6 Use a locating pin or stop block as an indexing device to ensure that all subsequent axle installations are consistently installed perpendicular with the axle housing cover to engine and transmission drive-shaft centerline.

6.7 *Torque Meter:* Include in the test equipment a torque meter installed in the drive shaft (see Fig. A2.3, A2.4, and A2.5) to measure the torque applied to the pinion. Install a Himmelstein⁹ inline torque meter Model numbers MCRT28061T(1-4) or MCRT2661TN(1-4) without a foot mount and a range of 10,000 lb-in (1130 N-m) shall be installed to measure pinion torque. Additional suffix letters only indicate allowable options.

6.8 *Signal Conditioning*—Use a Himmelstein Models 701 or 711 strain gage conditioner for signal conditioning. Set the low pass cut-off frequency at 10Hz.

6.9 *Digital Data Acquisition System:* System requires capability of measuring a minimum of five channels at sampling frequencies outlined in Section 10.

6.9.1 Do not use hardware or software filtering for the pinion torque channel during data acquisition periods of the test.

6.10 *Dynamometers:* Two axle dynamometers (Midwest Dynamatic, Model 3232)¹⁰ with suitable control equipment capable of maintaining specified test conditions.

6.11 *Engine Speed Control:* - System requires a device to maintain steady state conditions and also provide adjustable throttle acceleration and deceleration rates to attain specified shock loading torques.

6.11.1 Throttle Controller system – Use a Foxboro/Jordan¹¹ Controller, Model AD7530. Use a power transformer from Acme Electric Corp PN T-1-81058 or equivalent, primary volts 120X240, secondary volts 16/32 center tap, 0.500 kVA in conjunction with the Foxboro/Jordan Controller.

6.12 *Connecting Shafts*: Use connecting shafts of equal length ± 1 in. (25.4 mm) and less than 30 in. (762 mm) long from flange face to flange face. Use a tubing diameter of 3.5 ± 0.2 in. (88.9 ± 5.1 mm) OD, with a wall thickness of 0.095 ± 0.005 in. (2.41 ± 0.13 mm) if tubing is required to fabricate the shafts. Ensure the shafts are dynamically (spin) balanced and strong enough to handle torques up to 2,100 lbf-ft. Use an operating angle of $0 \pm 0.5^\circ$.

6.13 *Power Train*: The power train consists of a gasoline powered V-8 GM performance Ramjet 5.7L marine engine coupled with a five speed manual transmission capable of supplying specified shock loading torques. The engine and transmission operating angle shall be $0 \pm 0.5^\circ$.

6.13.1 All recommended replacement parts are available through local General Motors dealers. A list of these replacement parts are shown in Table 1. Do not make modifications to the engine that would affect the engines factory displacement or compression ratio.

Table 1
Recommended Power Train Replacement Parts List

Parts	Part Number
Ramjet Engine Includes ECM	12495515
Five Speed Transmission	15747134
Bell housing	15998496
Clutch Assembly	15002591
Throw Out Bearing	15705563
Dip stick	10190942
Dip stick Tube	12552920
Flywheel	10105832
Flywheel Bolt (6 req.)	12337973
Pilot Bearing	14061685
Master Cylinder	15727261
Actuating Cylinder	15046288
Pulley, Water Pump	14023155
Pulley, Crankshaft	14023147
Belt	9433720
Starter	10496873
Engine Control Unit	12489488
Throttle body from 2000 Corvette.	17113669
Throttle body TPS Connector	P/N 12116247

Throttle Body actuator motor Connector

P/N 12167121

K&N Inlet air Filter

P/N RD6020

6.14 *Drive Shaft*: - Welded steel tubing, 3.5 ± 0.2 in, (88.9 ± 0.51 mm) outside diameter, 0.095 ± 0.005 in. (2.41 ± 0.13 mm) wall thickness, 34.5 ± 1 in. (876.3 ± 25.4 mm) long from center weld to center weld. (See Figs.A2.3, A2.4, and A2.5). Dynamically (spin) balance the drive shaft and torque meter. The operating angle shall be $0 \pm 0.5^\circ$.

6.14.1 *Transmission U-Joint*: (Spicer 5-178X)¹².

6.14.2 *Pinion U-Joint*: (Spicer 5-153X).

6.14.3 *Flange Yoke*: Connects transmission yoke through u-joint to drive shaft.

6.14.4 *Pinion Drive Shaft Slip Yoke*: Connects the drive shaft through the u-joint to the axle yoke.

6.14.5 *Flange Adaptor*: Manufacture flange adaptor to specifications in Figs. A2.4 and A2.5.

6.15 *Spring Plate*: Manufacture spring plates to specification as shown in Fig. A2.8

6.16 *Spring Plate Rod Connection*: Mount a rod connecting the spring plate to the gear stand using $\frac{1}{2}$ in (0.953 cm). spherical rod ends, Figs. A2.6 and A2.7.

7. Reagents and Materials

7.1 *Sealing Compound* - Sealing Compound, where necessary, use Permatex No. 2 or equivalent.

7.2 *Cleaning Solvent – Cleaning Solvent*—Use solvent meeting ASTM D 235 – Type II, Class C requirements for Aromatic Content (0-2% vol.), Flash Point ($142^\circ\text{F}/61^\circ\text{C}$, min) and Color (not darker than +25 on Saybolt Scale or 25 on Pt-Co Scale). (**Warning.** Health Hazard, Combustible.) Obtain a Certificate of Analysis for each batch of solvent from the supplier.

7.3 *Contact Pattern Marking Compound* - Wayne Metal Working Compound # M 99B 111A¹³ or equivalent.

7.4 *Test Oil* – Use 3.5 pt (1655 cc) of test lubricant.

8. Preparation of Apparatus

8.1 *Cleaning of Reusable Hardware*: Clean as necessary with cleaning solvent, 7.2, all reusable parts including: axle shafts, thermocouples, axle housing cover, and all associated drain pans and funnels used for the addition of and collection of test oil.

8.2 Preparation of axle

8.2.1 Pretest contact pattern procedure: Record coast side pattern as received from manufacturer. Contact patterns shall be L2F+1, L2F0, L2F-1, L3F+1, L3F0, and L3F-1 for gear batch B6L544/P4L806. These contact patterns are only recommended for all other gear batches.

8.2.2 Record break and turn.

8.2.3 Record the backlash reported from the manufacturer. The readings shall be between .004 and .012 in. (0.102 to 0.305 mm).

8.2.3.1 Measure and record backlash at four equally spaced locations. Report the average and the four readings.

8.2.4 Proceed to 8.2.9 if contact pattern and backlash are acceptable. Proceed to 8.2.5 if the contact pattern or backlash needs adjustment.

8.2.5 Follow Dana Model 44 Maintenance Manual if contact pattern or backlash needs to be adjusted.

8.2.6 Assemble the gear unit using Dana Model 44 Maintenance Manual. Apply gear contact pattern grease on the drive and coast side of the ring. Place a 30 ± 5 lbf-ft. (40.7 ± 6.8 N-m) turning torque on the ring and pinion. Rotate ring and pinion through the gear contact pattern grease on the drive and coast side.

8.2.7 Proceed to Section 8.2.8 if the contact pattern and backlash are acceptable. If the contact pattern requires further adjustment, repeat Sections 8.2.5 and 8.2.6 until an acceptable pattern is obtained.

8.2.8 Measure and record backlash at four equally spaced locations. Report the average and the four readings.

8.2.9 Clean the gear with cleaning solvent, 7.2, when gear contact pattern and backlash are at acceptable levels.

8.2.10 *Cleaning*: Wash the test unit in cleaning solvent, 7.2, paying particular attention to the pinion bearing to remove all preservative oil. Blow dry with clean dry compressed air.

8.2.11 Lubricate the carrier bearing, pinion bearings, differential gears, and the ring and pinion gears using the test lubricant.

8.2.12 Thoroughly drain the lubricant added in 8.2.11 by placing the pinion in a vertical position with the yoke up and the cover off for a minimum of 5 min prior to addition of test oil.

8.2.13 Install test unit on stand with pinion and axle shaft center lines horizontal. The operating angle shall be $0 \pm 0.5^\circ$. After installing the axle, ensure that the hinge plate assembly is free.

8.2.14 Connect the dynamometers and drive shaft to the test unit.

8.2.15 Fill the differential housing at or prior to this point with 3.5 ± 0.1 pints (1655 \pm 50mL) of test lubricant.

9. Calibration and Standardization

9.1 *Reference Oils:*

9.1.1 To correctly evaluate non-reference oil test performance, test stands shall first be calibrated by completing tests using reference oils available from the ASTM Test Monitoring Center (TMC), see A4. Laboratories wishing to calibrate test stands shall participate in the referencing and stand calibration program administered by the TMC. Reference oils are distributed by the TMC for calibration. Report all reference oil test data to the TMC.

9.1.2 Do not submit reference oils to physical or chemical analyses for identification purposes. Identifying the oils by analyses could undermine the confidentiality required to operate an effective blind reference oil system. Therefore, reference oils are supplied with the explicit understanding that they will not be subjected to analyses other than those specified within this Test method unless specifically authorized by the TMC. In such cases where analyses are authorized, supply written confirmation of the circumstances involved, the data obtained, and the name of the TMC person authorizing the analysis to the TMC.

9.2 *Test Stand Calibration* - Calibration is established upon satisfactory completion of a reference oil test sequence that meets established reference oil targets. Each calibration sequence will consist of 3 operationally valid and statistically acceptable calibration tests. Each operationally valid test will be considered statistically acceptable if the end of test pinion coast side scoring meets the Shewhart limits as published by the Test Monitoring Center. Specific Shewhart limits are defined for each gear batch and reference oil combination. Repeat any operationally valid calibration test in the calibration sequence with an end of test pinion coast side scoring value exceeding the Shewhart limits until acceptable pinion scoring results are achieved. Conduct a discrimination oil test on the test stand every 6 months from the completion of the last test in the calibration sequence or after 4 calibration sequences. The end of test pinion coast side scoring value of the discrimination oil test shall be a minimum of twice the average value of the 3 acceptable reference oil tests for the test to be considered acceptable. If a second discrimination oil test is needed, this discrimination oil test if acceptable, will count as 1 of the 15 non-reference oil tests. Repeat the calibration sequence, consisting of the 3 reference oil tests and the discrimination oil test, if both discrimination oil tests do not meet the above requirements. For all reference oil tests, the end of test coast side pinion scoring shall be equal to or greater than the end of test ring coast side scoring for the test to be acceptable.

9.2.1 *New Test Stand Calibration* - A new test stand is considered calibrated upon satisfactory completion of reference oil tests, as prescribed by the TMC that meet established reference oil targets. TMC requires new test stand inspection for compliance with this test method.

9.2.2 *In-Service Stand Calibration* - Calibrate previously referenced test stands:

9.2.2.1 After every fifteenth non-referenced oil test, or

9.2.2.2 After three months since the last acceptable reference oil test sequence, or

9.2.2.3 After a test stand is moved, or

9.2.2.4 After changing axle batches, or

9.2.2.5 After changing throttle settings, or

9.2.2.6 After changing torque settings, or

9.2.2.7 After major computer changes, or

9.2.2.8 After a test not conforming to this test method was run in the stand since the last acceptable reference test.

9.3 *Reference oil test frequency*--Reference oil test frequency may be adjusted due to the following reasons:

9.3.1 *Procedural Deviations* – On occasions when a laboratory becomes aware of a significant deviation from the test method, such as might arise during an in-house review or a TMC inspection, the laboratory and the TMC shall agree on an appropriate course of action to remedy the deviation. This action may include the shortening of existing reference oil calibration periods.

9.3.2 *Parts and Fuel Shortages* – Under special circumstances, such as industry-wide parts or fuel shortages, the surveillance panel may direct the TMC to extend the time intervals between reference oil tests. These extensions shall not exceed one regular calibration period.

9.3.3 *Reference Oil Test Data Flow* – To ensure continuous severity and precision monitoring, calibration tests are conducted periodically throughout the year. There may be occasions when laboratories conduct a large portion of calibration tests in a short period of time. This could result in an unacceptably large time frame when very few calibration tests are conducted. The TMC can shorten or extend calibration periods as needed to provide a consistent flow of reference oil test data.

Adjustments to calibration periods are made such that laboratories incur no net loss (or gain) in calibration status.

9.3.4 *Special Use of the Reference Oil Calibration System* – The surveillance panel has the option to use the reference oil system to evaluate changes that have potential impact on test severity and precision. This option is only taken when a program of donated tests is not feasible. The surveillance panel and the TMC shall develop a detailed plan for the test program. This plan requires all reference oil tests in the program to be completed as close to the same time as possible, so that no laboratory/stand calibration is left in an excessively long pending status. In order to maintain the integrity of the reference oil monitoring system, each reference oil test is conducted so as to be interpretable for stand calibration. To facilitate the required test scheduling, the surveillance panel may direct the TMC to lengthen and shorten reference oil calibration periods within laboratories such that the laboratories incur no net loss (or gain) in calibration status.

9.4 *Donated Reference Oil Test Programs* – The Surveillance Panel is charged with maintaining effective reference oil test severity and precision monitoring. During times of new parts introductions, new or re-blended reference oil additions, and procedural revisions, it may be necessary to evaluate the possible effects on severity and precision levels. The surveillance panel may choose to conduct a program of donated reference oil tests in those laboratories participating in the monitoring system, in order to quantify the effect of a particular change on severity and precision. Typically, the surveillance panel requests its panel members to volunteer enough reference oil test results to create a robust data set. Broad laboratory participation is needed to provide a representative sampling of the industry. To ensure the quality of the data obtained, donated tests are conducted on calibrated test stands. The surveillance panel shall arrange an appropriate number of donated tests and ensure completion of the test program in a timely manner.

9.5 Designate a sequential test run number, for each stand, before the start of each test. All test starts, including aborted tests and operationally invalid tests, shall retain their test run number.

9.6 *Instrument Calibration* - Calibrate the wheel and pinion speed measuring systems and axle oil temperature control system at a minimum of every three months or 60 non-reference oil tests, whichever occurs first. Perform an instrument calibration against a known standard traceable to either the National Institute of Standards and Technology (NIST) or to a physical constant.

9.6.1 Calibrate the pinion torque measuring device, using a dead weight calibration, prior to each reference oil test sequence. Perform the calibration on both the positive (drive) and negative (coast) side of zero.

9.7 *Engine Throttle Body Calibration*

9.7.1 Warm the engine up until the coolant temperature is greater than 150°F (65.6°C).

9.7.2 Connect a voltmeter to the throttle position sensor (TPS) to measure the TPS voltage sent to the engine ECM.

9.7.3 Adjust the Foxboro/Jordon zero potentiometer to close the throttle until engine idle speed is

at 675 ± 75 r/min (71 ± 8 rad/s). Record the TPS voltage.

9.7.4 Set the throttle controller at 100% output, adjust the Foxboro/Jordon “span” potentiometer until the observed TPS voltage is 1.3 ± 0.1 V higher than the voltage recorded in Section 9.7.3.

10. Procedure for Conducting the Test

10.1 The test axles are batch specific. See TMC Memo 94-200 for approved gear batches and test targets.

10.2 Gear Conditioning-- All ramp targets should be reached in approximately five min. Minimize drive torque to prevent drive side scoring.

10.2.1 Conditioning 1:

10.2.1.1 Set the axle oil temperature control equipment at a set point of 225°F (107.2°C). When the axle oil temperature reaches set point, maintain the temperature within $225 \pm 10^{\circ}\text{F}$ ($107.2 \pm 5.6^{\circ}\text{C}$) until conditioning is complete.

10.2.1.2 Shift Gears: With the engine at operating temperature set the engine idle speed to 700 ± 200 r/min (73 ± 21 rad/s). Prior to shifting gears set the engine speed manual output to achieve approximately 2000 r/min (209 rad/s). With no load on the dynamometers smoothly shift the transmission through the gears (without bucking the axle) allowing the engine to recover to approximately 1500 r/min (157 rad/s) between shifts. Shift through the gears until 1:1 ratio (4th gear) is reached.

10.2.1.3 Ramp & Condition: Set data acquisition to record pinion torque, wheel speed and axle temperature at a minimum of 1Hz. Accelerate both wheels to a speed of 575.5 (60 ± 0.5 rad/s) wheel r/min (pinion speed 2352 ± 20 r/min (246 ± 2 rad/s)). Apply a dynamometer excitation to achieve a pinion torque of 60 ± 20 lbf-ft (81 ± 27 N-m). When both conditions are met, begin conditioning phase 1 and maintain for 10 ± 0.5 min. At the end of this steady state operation lock dynamometer excitation at the output necessary to achieve 60 lbf-ft (81 N-m). Immediately proceed to 10.2.2.

10.2.2 Conditioning 2:

10.2.2.1 Set data acquisition to record pinion torque and wheel speed at a minimum of 10Hz and axle temperature at a minimum of 1Hz. While maintaining the fixed dynamometer excitation, slowly cycle the wheel speed from 575 ± 20 r/min (60 ± 0.5 rad/s) to 385 ± 20 r/min (40 ± 0.5 rad/s). Maintain the fixed dynamometer excitation settings and control throttle movement slowly enough to maintain pinion torque values sufficient to properly condition the drive and coast side of the axle.

Complete four cycles then immediately proceed to 10.2.3. The total time of the four cycles shall not exceed 5 min.

Note 1: It is believed that if the shape of both drive and coast segments of Conditioning 2 and Conditioning 4 are flat topped in nature (without any spikes in the acceleration or deceleration torque that would indicate a shock) the torque values found from this data stream will be a better representation of the gear conditioning.

10.2.3 Conditioning 3:

10.2.3.1 Maintain the axle oil temperature control at $225^{\circ} \pm 10^{\circ}\text{F}$ ($107.2^{\circ} \pm 5.6^{\circ}\text{C}$).

10.2.3.2 Ramp & Condition: Set data acquisition to record pinion torque, pinion speed and axle temperature at a minimum of 1Hz. Accelerate both wheels to a speed of 815 ± 5 (85 ± 0.5 rad/s) wheel r/min. Apply a dynamometer excitation to achieve a pinion torque of 70 ± 20 lbf-ft (95 ± 27 N-m). When both conditions are met, maintain for 20 ± 0.5 min. At the end of this steady state operation lock dynamometer excitation at the output necessary to achieve 70 lbf-ft (95 N-m). Immediately proceed to 10.2.4.

10.2.4 Conditioning 4:

10.2.4.1 Set data acquisition to record pinion torque and wheel speed at a minimum of 10Hz and axle temperature at a minimum of 1Hz. While maintaining the fixed dynamometer excitation, slowly cycle the wheel speed from 815 ± 20 r/min (85 ± 2 rad/s) to 670 ± 20 r/min (70 ± 2 rad/s). Maintain the fixed dynamometer excitation settings and control throttle movement slowly enough to maintain pinion torque values sufficient to properly condition the drive and coast side of the axle. Complete four cycles then immediately proceed to 10.2.4.2. The total time of the four cycles shall not exceed 5 min.

10.2.4.2 Shift transmission into neutral to avoid additional coast side conditioning. Bring engine r/min down to idle.

10.2.5 Inspection 1: (**Warning:** Differential is extremely hot. Hot oil can produce vapors.)

10.2.5.1 Inspect ring gear and report approximate drive and coast percent scoring. Inspection should take approximately 5 min. Make an effort to minimize the time spent during the inspection.

10.3 Shock Series 1:

10.3.1 Shock Series 1 Preparation:

10.3.1.1 Set the engine speed manual output to achieve approximately 2000 r/min (209 rad/s), prior to shifting gears. With no load on the dynamometers smoothly shift the transmission through

the gears (without bucking the axle) allowing the engine to recover to approximately 1500 rpm (157 rad/s) between shifts. Shift through the gears until 1:1 ratio (4th gear) is reached. Set temperature control set point to 200° F (93.3°C).

10.3.1.2 Set data acquisition to record pinion torque, wheel speed and axle temperature at a minimum of 1Hz. Slowly accelerate the driveline until wheel speed is 530±5 r/min (55±0.5 rad/s) (pinion speed 2168±20 r/min (227±2 rad/s)). Apply dynamometers excitation to maintain 50±10 lbf-ft (68±14 N-m). pinion torque.

10.3.1.3 Differential housing oil temperature shall be 200±5° F (93.3±2.8°C) at the start of Shock Series 1. See A1.2.2.2 for L-42 Canadian Version test.

10.3.1.4 Once pinion speed, pinion torque, and axle lubricant temperature reach steady state, lock dynamometer excitation at the output necessary to maintain 50±10 lbf-ft (68±14 N-m), turn off axle oil temperature control, and proceed immediately to 10.3.2.

10.3.2 Shock Series 1 Procedure:

10.3.2.1 Turn the axle cooling water off after the ramp-up of Shock Series 1. Ensure that the axle cooling water is off during the shocks. See A1.2.2.3 for L-42 Canadian Version test.

10.3.2.2 Record axle oil temperature at the start of Shock Series 1 on the appropriate form. Maintain the fixed dynamometer excitation until the transmission is shifted into neutral at end of Shock Series 1 in 10.3.2.3

10.3.2.3 Set data acquisition to acquire pinion torque data at a minimum of 100 Hz, wheel speed at a minimum of 10 Hz and axle temperature at a minimum of 1Hz While maintaining the fixed dynamometer excitation begin cycling the wheel speed from 530±20 r/min (55±2 rad/s) to 1050±20 r/min (110±2 rad/s). Complete five cycles, ending by accelerating the engine to bring the pinion torque back to near 0, then proceed to 10.3.2.4.

10.3.2.4 Shift transmission into neutral to avoid additional coast side conditioning. Bring engine speed down to idle.

10.4 Inspection 2: (**Warning:** Differential is extremely hot. Hot oil can produce vapors.)

10.4.1 Inspect ring gear and report approximate drive and coast percent scoring. Inspection should take approximately 5 min. Make every effort to minimize the time spent during the inspection to maintain the axle temperature. Do not cool the axle at the end of shock series 1. Ensure the cooling water remains turned off for the remainder of the test. Table A1.1 shows alternative test versions.

10.5 Shock Series 2:

10.5.1 Shock Series 2 Preparation:

10.5.1.1 If the axle oil temperature is greater than 280°F (137.8°C) after Inspection 2, allow the axle oil temperature to cool (*without cooling water*) until axle oil temperature is less than or equal to 280°F (137.8°C) before shifting transmission through the gears. If the axle oil temperature is less than or equal to 280°F (137.8°C) after Inspection 2, proceed immediately to 10.5.1.2.

10.5.1.2 Set the engine speed manual output to achieve approximately 2000 r/min (209 rad/s) prior to shifting gears. With no load on the dynamometers smoothly shift the transmission through the gears (without bucking the axle) allowing the engine to recover to approximately 1500 rpm (157 rad/s) between shifts. Shift through the gears until 1:1.67 ratio (3rd gear) is reached.

10.5.1.3 Set data acquisition to record pinion torque, wheel speed and axle temperature at a minimum of 1Hz. Slowly accelerate the driveline until wheel speed is 530±5 r/min (55±0.5 rad/s) (pinion speed 2168±20 r/min (227±2 rad/s)). Apply dynamometers excitation to achieve 70±10 lbf-ft (95±14 N-m) pinion torque. When steady state operation is achieved lock dynamometer excitation at the output necessary to maintain 70±10 lbf-ft (95±14 N-m).

10.5.1.4 Record axle oil temperature at the start of Shock Series 2 on the appropriate form. Axle oil temperature shall be less than or equal to 280°F (137.8°C) at the start of Shock Series 2. See A1.2.2.4 for L-42 Canadian Version test.

10.5.1.5 Set data acquisition to acquire pinion torque data at a minimum of 100 Hz, wheel speed at a minimum of 10 Hz and axle temperature at a minimum of 1Hz While maintaining the fixed dynamometer excitation begin cycling the wheel speed from 530±20 r/min (55±2 rad/s) to 630±20 r/min (66±2 rad/s). Complete ten cycles, ending by accelerating the engine to bring the pinion torque back to near 0, then proceed to 10.5.1.6.

10.5.1.6 Shift transmission into neutral to avoid additional coast side conditioning. Bring engine speed down to idle.

10.5.1.7 Record end of test time and test minutes in the appropriate test fields.

10.6 Tear down Procedure: (**Warning:** The axle is very hot. Use caution.)

10.6.1 Disconnect dynamometers and drive shafts. Perform end of test procedures.

10.6.2 Check backlash in four equally spaced locations and record measurements On the appropriate form.

10.6.3 Disassemble axle for rating of ring and pinion.

10.6.4 Clean ring and pinion with cleaning solvent, see 7.2 and dry.

11. Determination of Test Results

11.1 *Part Rating:*

11.1.1 Rate and report both drive and coast side of pinion and ring gear for percent of total tooth area that exhibits scoring, see CRC manual 21⁵. Compare the percent scoring for the non-reference oil tests to the percent scoring for the three most recent acceptable reference oil tests.

11.1.2 For a valid rating ensure that the individual rating the test has participated in an ASTM gear rater calibration workshop within the previous twelve months.

11.2 A non-reference oil test that has not been run in a calibrated test stand or not conducted on approved hardware or both is considered non-interpretable. Note on the cover page of the test report that the test is non-interpretable and that it has not been conducted in a valid manner in accordance with the test method.

11.3 Reference oil tests, other than the discrimination oil test, and non-reference oil tests shall exhibit end of test pinion coast side scoring shall be equal to or greater than the end of test ring coast side scoring.

11.4 Reference oil tests, other than the discrimination oil tests, and non-reference oil tests that exhibit drive side scoring shall be considered non-interpretable.

11.5 Test Validity—The test is determined to be operationally valid if the percent deviation of the critical operating parameters and number of shutdowns are within the limits specified and defined in Annex A5.

11.6 Round test results according to Practice E 29.

12. Interpretation of Operational Data

12.1 *Data Stream Interpretation:* Fig. A2.11 through A2.21 are required in the final test report. Examples shown are meant to display all data collected and optimize the resolution of the data. The X and Y axis may be rescaled to achieve this.

12.1.1 *Lubricant Temperature:*

12.1.1.1 The initial oil temperature for each test sequence shall consist of the average of the first five sec of data during the sequence.

12.1.1.2 The maximum oil temperature for each test sequence is the single maximum value experienced during the sequence.

12.1.1.3 Referring to Fig A.21, plot all data collected from the start of Conditioning 1 to the end of Shock Series 2. Use the X axis as the elapse time data.

12.1.2 *Wheel Speeds:*

12.1.2.1 During Conditioning 1, see Fig. A211 location (A) and Conditioning 3, see Fig. A2.12 location (D), the reported wheel speeds shall be the average over the steady-state sequence.

12.1.2.2 Referring to Fig. A2.11 and Fig. A2.12, during Conditioning 2 or 4, the value of the maximum and minimum single scan conditioning 2 and 4 wheel speeds are located at (B₁-B₃ & C₁-C₄) and (E₁-E₃ and F₁-F₄) respectively. For both conditioning 2 and 4, independently report the maximum, minimum, and average of the single scan maximum speeds and the maximum, minimum, and average of the single scan minimum speeds by including all peaks and valleys not connected to a steady state operating condition phase.

12.1.2.3 Referring to Fig. A2.13, during Shock Series 1, the value of the maximum and minimum single scan Shock Series 1 wheel speeds are to be found at locations (G₁-G₅) and (H₁-H₄) respectively. Report the maximum, minimum, and average of the single scan maximum speeds and the maximum, minimum, and average of the single scan minimum speeds by including all peaks and valleys not connected to a steady state operating condition phase.

12.1.2.4 Referring to Fig. A2.14, during Shock Series 2, the value of the maximum and minimum single scan Shock Series 2 wheel speeds are to be found at locations (I₁-I₁₀) and (J₁-J₉) respectively. Report the maximum, minimum, and average of the single scan maximum speeds and the maximum, minimum, and average of the single scan minimum speeds by including all peaks and valleys not connected to a steady state operating condition phase.

12.1.3 *Pinion Torque Conditioning 1 - 4:*

12.1.3.1 During Conditioning 1, see Fig. A2.15 location (K) and Conditioning 3, see Fig. A2.16 location (N), the reported pinion torque is the average torque over the steady state sequence.

12.1.3.2 Refer to Fig. A2.17, Conditioning 2 pinion torque, and Fig. A2.18, Conditioning 4 pinion torque. Locations (L₀-L₇) and locations (M₀-M₇) represent the zero line crossings for the pinion torque. The drive side gear contact segments are between points 1 and 2, 3 and 4, and 5 and 6, and 7 and beyond. The coast side gear contact segments are between points 0 and 1, 2 and 3, 4 and 5 and 6 and 7.

12.1.3.3 Referring to Fig. A2.17 and Fig. A2.18, Conditioning 2 pinion torque and conditioning 4 pinion torque, the maximum and minimum single scan conditioning 2 and 4 pinion torque values are located at (B₁-B₃ and C₁-C₄) and (E₁-E₃ and F₁-F₄) respectively. For both conditioning 2 and 4, independently report the maximum, minimum, and average of the single scan maximum pinion torques and the maximum, minimum, and average of the single scan minimum pinion torques by including all peaks and valleys not connected to a steady state operating condition phase. Ignore the drive side gear contact segments beyond zero crossings 7 since their stop times are not well defined.

12.1.4 *Pinion Torque - Shock Series 1:*

12.1.4.1 Referring to Fig. A2.19, the zero pinion torque crossings (O₀-O₉) are located where the pinion torque value crosses zero. The coast side gear contact segments are between points 0 and 1, 2 and 3, 4 and 5, 6 and 7, and 8 and 9. The drive side gear contact segments are between points 0 and prior, 1 and 2, 3 and 4, 5 and 6, and 7 and 8.

12.1.4.2 Referring to Fig. A2.19, during Shock Series 1, the value of the maximum and minimum single scan Shock Series 1 pinion torques are to be found at locations (P₁-P₅) and (Q₁-Q₅) respectively. Report the maximum, minimum, and average of the single scan maximum pinion torques and the maximum, minimum, and average of the single scan minimum pinion torques.

12.1.4.3 Calculate and report the maximum, minimum, and average drive side gear contact segment time. Calculate and report the maximum, minimum, and average coast side gear contact segment time. For these time calculations, ignore the first drive side segment and the last coast side segment since zero crossings are not well defined.

12.1.5 *Pinion Torque – Shock Series 2:*

12.1.5.1 Referring to Fig. A2.20, the zero pinion torque crossings (R₀-R₁₉) are located where the pinion torque value crosses zero. The coast side gear contact segments are between points 0 and 1, 2 and 3, 4 and 5, 6 and 7, 8 and 9, 10 and 11, 12 and 13, 14 and 15, 16 and 17, and 18 and 19. The drive side gear contact segments are between points 0 and prior, 1 and 2, 3 and 4, 5 and 6, 7 and 8, 9 and 10, 11 and 12, 13 and 14, 15 and 16, and 17 and 18.

12.1.5.2 Referring to Fig. A2.20, during Shock Series 2, the value of the maximum and minimum single scan Shock Series 2 pinion torques are to be found at locations (S₁-S₁₀) and (T₁-T₁₀) respectively. Report the maximum, minimum, and average of the single scan maximum pinion torques and the maximum, minimum, and average of the single scan minimum pinion torques.

12.1.5.3 Calculate and report the maximum, minimum, and average drive side gear contact segment time. Calculate and report the maximum, minimum, and average coast side gear contact segment time. For these time calculations, ignore the first drive side segment and the last coast side segment since zero crossings are not well defined.

12.1.6 *Total Test Time*

12.1.6.1 Calculate and report total test time starting from the beginning of Conditioning 1 to the end of Shock 2.

13. Report

13.1 For reference oil tests, the standardized report form set and data dictionary for reporting the test results and for summarizing the operational data are required. Fill out the report forms according to the formats shown in the Data Dictionary. Report forms and data dictionary are available on the ASTM Test Monitoring Center Web Page at <http://astmtmc.cmu.edu/> or can be obtained in hardcopy format from the TMC.

13.2 When reporting reference oil test results to the TMC, transmit by facsimile the complete report form package within five days of test completion. Within 30 days of test completion, mail a copy of the final test report to the TMC. Electronic transfer of test results is also permitted for approved laboratories (see 13.3).

ASTM Test Monitoring Center
6555 Penn Avenue
Pittsburgh, PA 15206-4489

13.3 *Electronic Transmission of Test Results*—Electronic transfer of reference and non-reference oil test report data may be done utilizing the Flat File Transmission Format contained in Section 2 of the ASTM Data Communications Committee Test Report Transmission Model, available from the ASTM TMC.

13.4 *Deviations from Test Operational Limits*—Report all deviations from specified test operational limits on the appropriate form.

13.5 When reporting the stand set-up version, use the L-42 data dictionary format of yyyyymmdd-x.
where;

yyyyymmdd is the date the calibration sequence is started,

and x is a number that starts with one and is incremented each time a change is made that requires that calibration sequence to be started over.

Changing the torque settings is an example of a change that would require the calibration sequence to start over.

14. Precision and Bias

14.1.1 Test precision is established on the basis of operationally valid reference oil test results monitored by the TMC.

14.1.2 *Intermediate Precision conditions*-conditions where test results are obtained with the same test method using the same oil, with changing conditions such as operators, measuring equipment, test stands, test engines and time.

Note 2-Intermediate precision is the appropriate term for this test method rather than repeatability, which defines more rigorous within-laboratory conditions.

14.1.2.1 *Intermediate Precision Limit (i.p.)*—The difference between two results obtained under intermediate precision conditions that would, in the long run, in the normal and correct conduct of the test method, exceed the values shown in Table 2 in only one case in twenty. When only a single test result is available, the Intermediate Precision Limit can be used to calculate a range (test result \pm Intermediate Precision Limit) outside of which a second test result would be expected to fall about one time in twenty.

14.1.3 *Reproducibility Conditions*—conditions where test results are obtained with the same test method using the same test oil in different laboratories with different operators using different equipment.

14.1.3.1 *Reproducibility Limit (R)*—The difference between two results obtained under reproducibility conditions that would, in the long run, in the normal and correct conduct of the test method, exceed the values shown in Table 2 in only one case in twenty. When only a single test result is available, the Reproducibility Limit can be used to calculate a range (test result \pm Reproducibility Limit) outside of which a second test result would be expected to fall about one time in twenty.

Table 1 Reference Oil Statistics ^A

Variable, Merits	Intermediate Precision		Reproducibility	
	$s_{i.p.}^B$	$i.p.^C$	s_R^B	R^C
Scoring	5.49	15.37	5.49	15.37

^A These statistics are based on results obtained on TMC Reference Oil 116 as of May 7, 2007

^B s = standard deviations.

^C This value is obtained by multiplying the standard deviation by 2.8.

14.2 *Bias:*

14.2.1 No estimate of bias is possible, as the behavior of a lubricant is determined only under the specific conditions of the test and no absolute standards exist.

15. Keywords

15.1 final drive axle; L-42; extreme pressure lubricants; automotive gear oils, hypoid gear lubricants.

A1 L-42 Test Versions

A1.1 Test versions - This test method has two commonly used versions. The test procedures and conditions described previously in this test method will be referred to as the standard version. All versions maintain the same test procedures, pinion loads, and wheel speed conditions. The differences occur in the axle oil temperature only. Table A1.1 below describes each version.

Table A1.1 Test Versions^{A,B}

Test Version	Shock Series 1 <u>Starting Temperature</u>	Shock Series 2 <u>Starting Temperature</u>
Standard	200+/-5°F (93.3±2.8°C)	See Section 10.5.1.1
Canadian	175+/-5°F (79.4±2.8°C)	200+/-5°F (93.3±2.8°C)

NOTE 3: In shock series 2 for the Canadian test method, the cooling water control set point is set to 200°F (93.3°C). The maximum rise above the starting temperature during the shock sequence is to be 15° (8.3°C), or the test is considered non-interpretable.

^A Both versions use the same wheel speed, load conditions, and test procedures (except Note 3) which are described in Section 10.

^B The Canadian test version is typically used for evaluation of 75Wxx lubricants.

A1.2 L-42 Canadian Version Test Requirements

A1.2.1 *Calibration Test Acceptance* (see Section 9):

A1.2.1.1 Calibration status of the L-42 Canadian Version test is determined by successfully calibrating a test stand according to the L-42 Standard Version test requirements detailed in Section 9. In other words, a stand that is calibrated for the L-42 Standard Version test is automatically calibrated for the L-42 Canadian Version test.

A1.2.2. *Test Procedure*:

A1.2.2.1 Operate the test as outlined in 10.1 through 10.5 of the L-42 Standard Version test with the exceptions of the following sections. The procedure modifications listed in this annex refer to the corresponding section of the L-42 Standard Version test.

A1.2.2.2 Differential housing oil temperature is 175±5° F (79.4±2.8°C) at the start of Shock Series1, see 10.3.1.3.

A1.2.2.3 Ensure that the axle cooling water remains turned on through out the remainder of the test, see 10.3.2.1.

A1.2.2.4 Set and maintain the differential housing oil temperature at 200±5° F (93.3±2.8°C), see 10.5.1.1.

ANNEXES
(Mandatory Information)

A2. System Drawings

The following drawings are shown to assist the users of this test method.

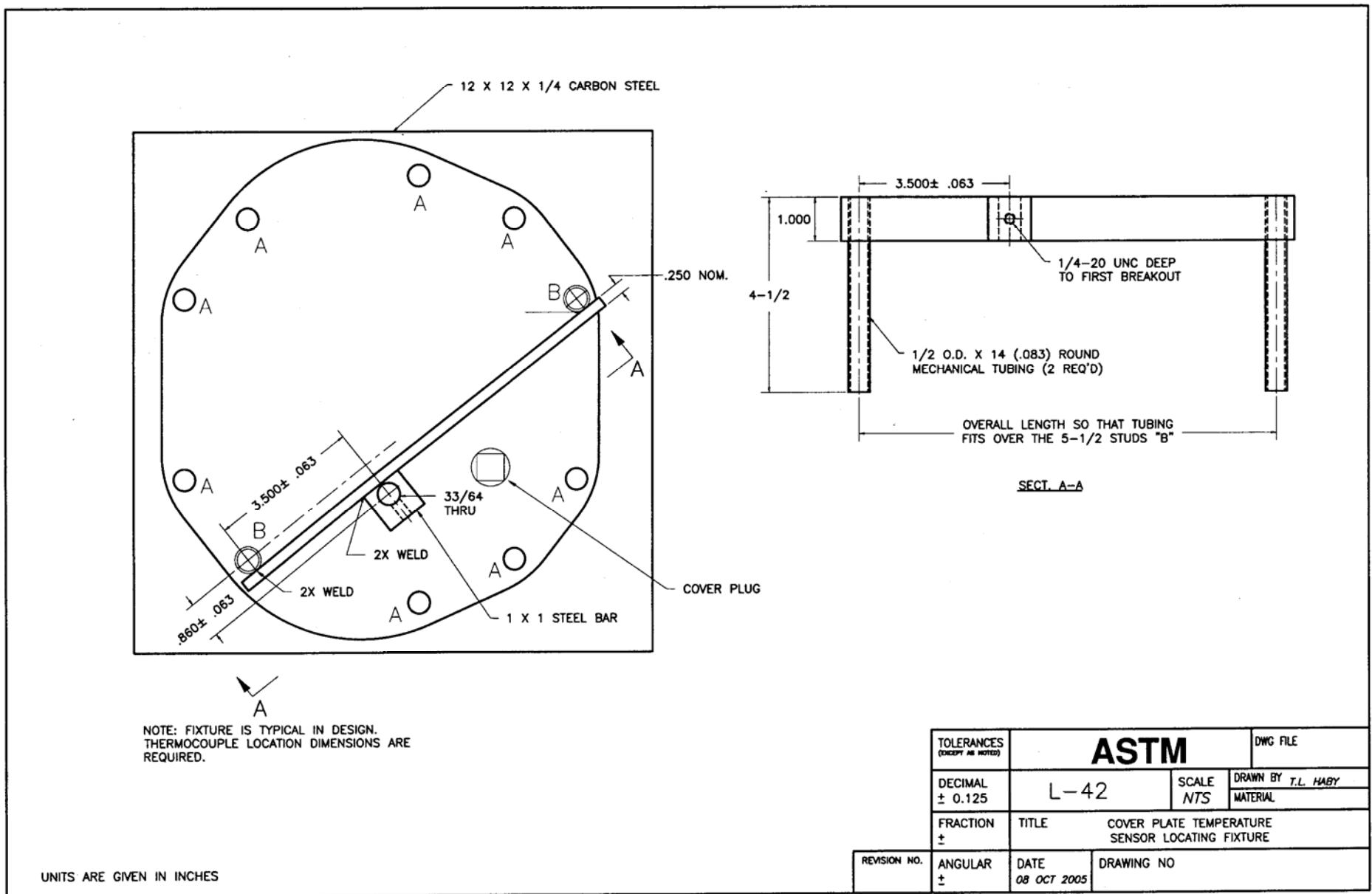

FIG. A2.1 Cover Plate Temperature Sensor Locating Device

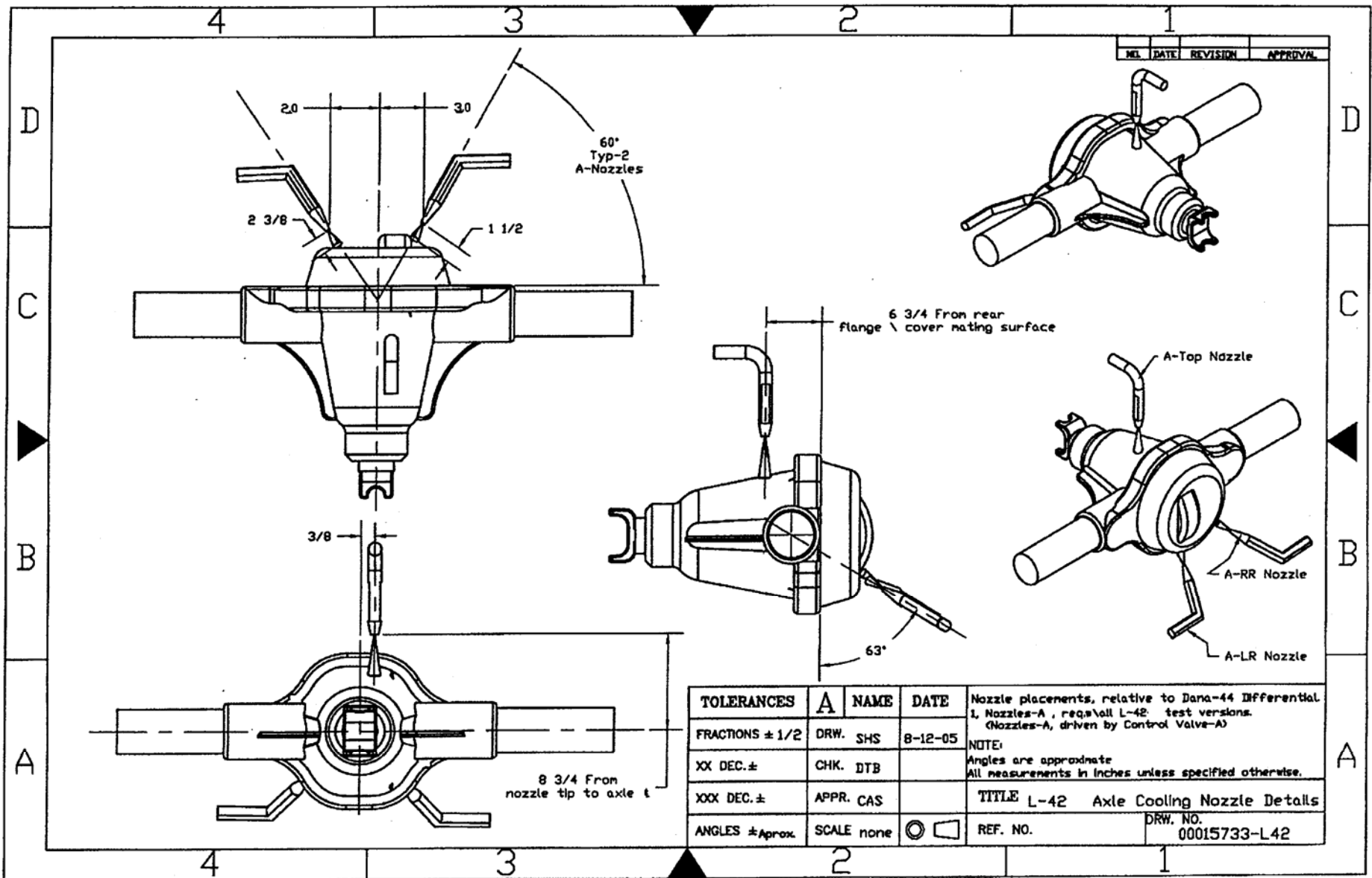

FIG. A2.2 Location of Spray Nozzles On Axle

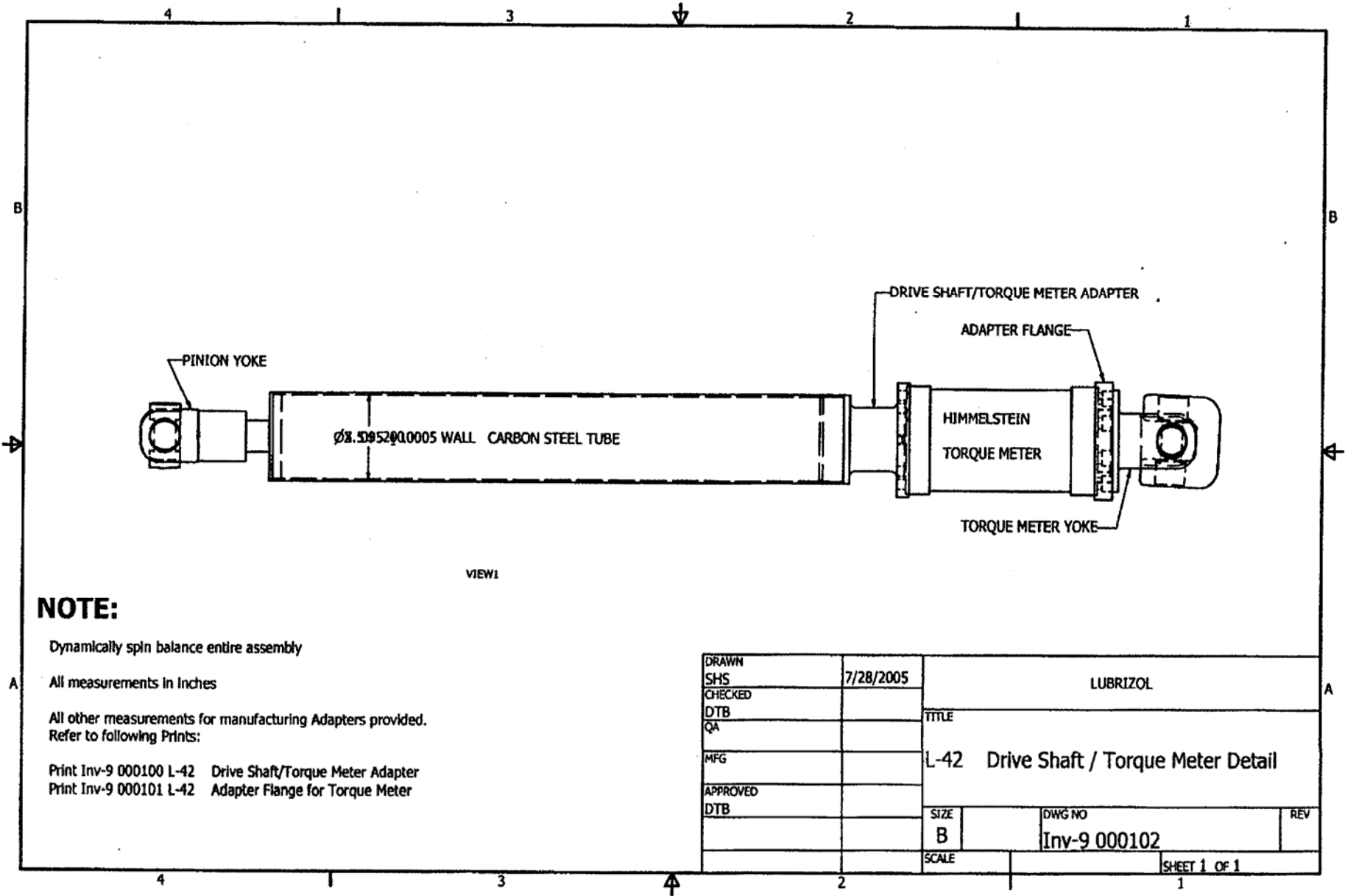

FIG. A2.3 Drive Shaft Torque Meter Assembly

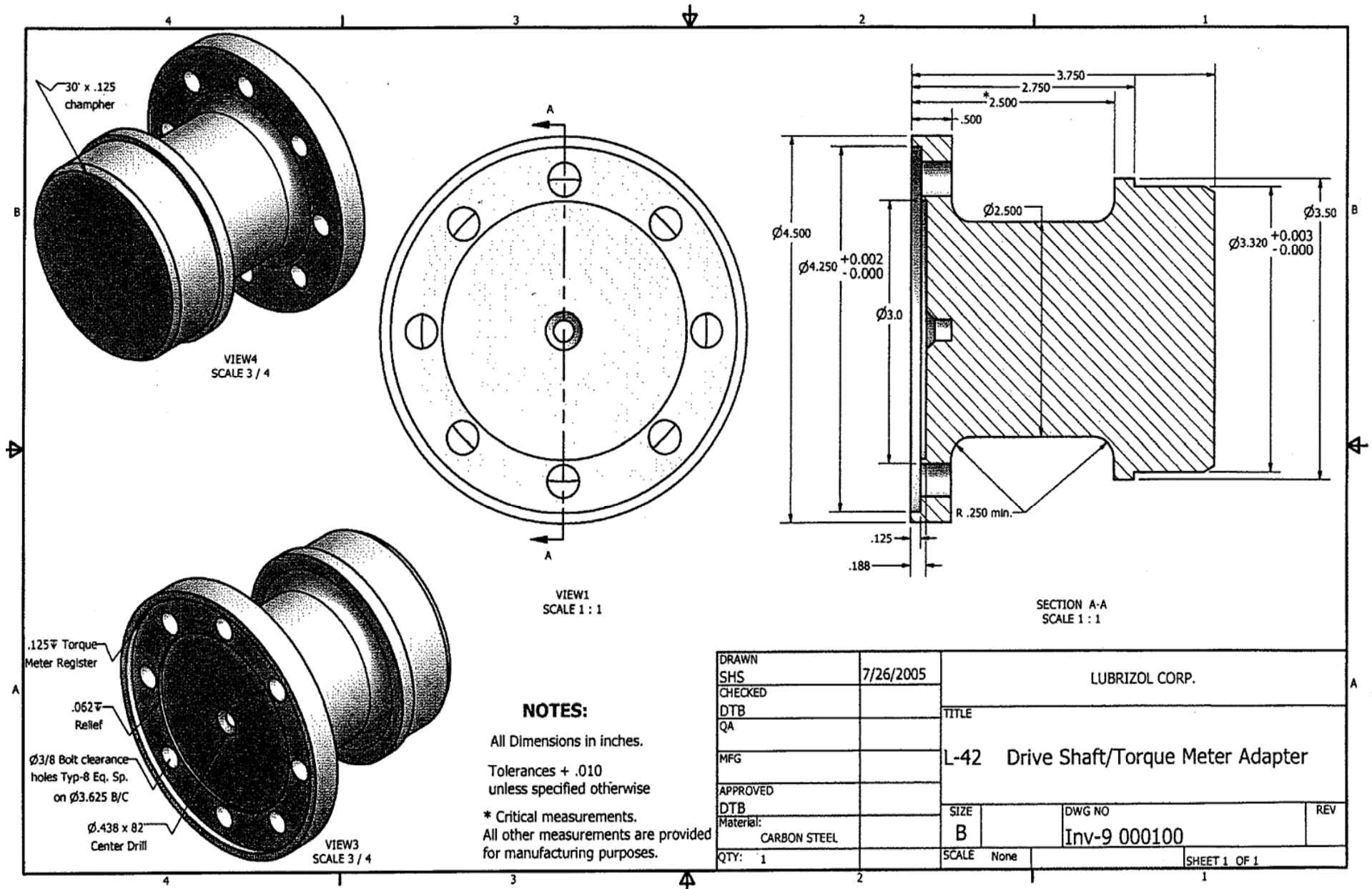

FIG. A2.4 Torque Meter Adapter

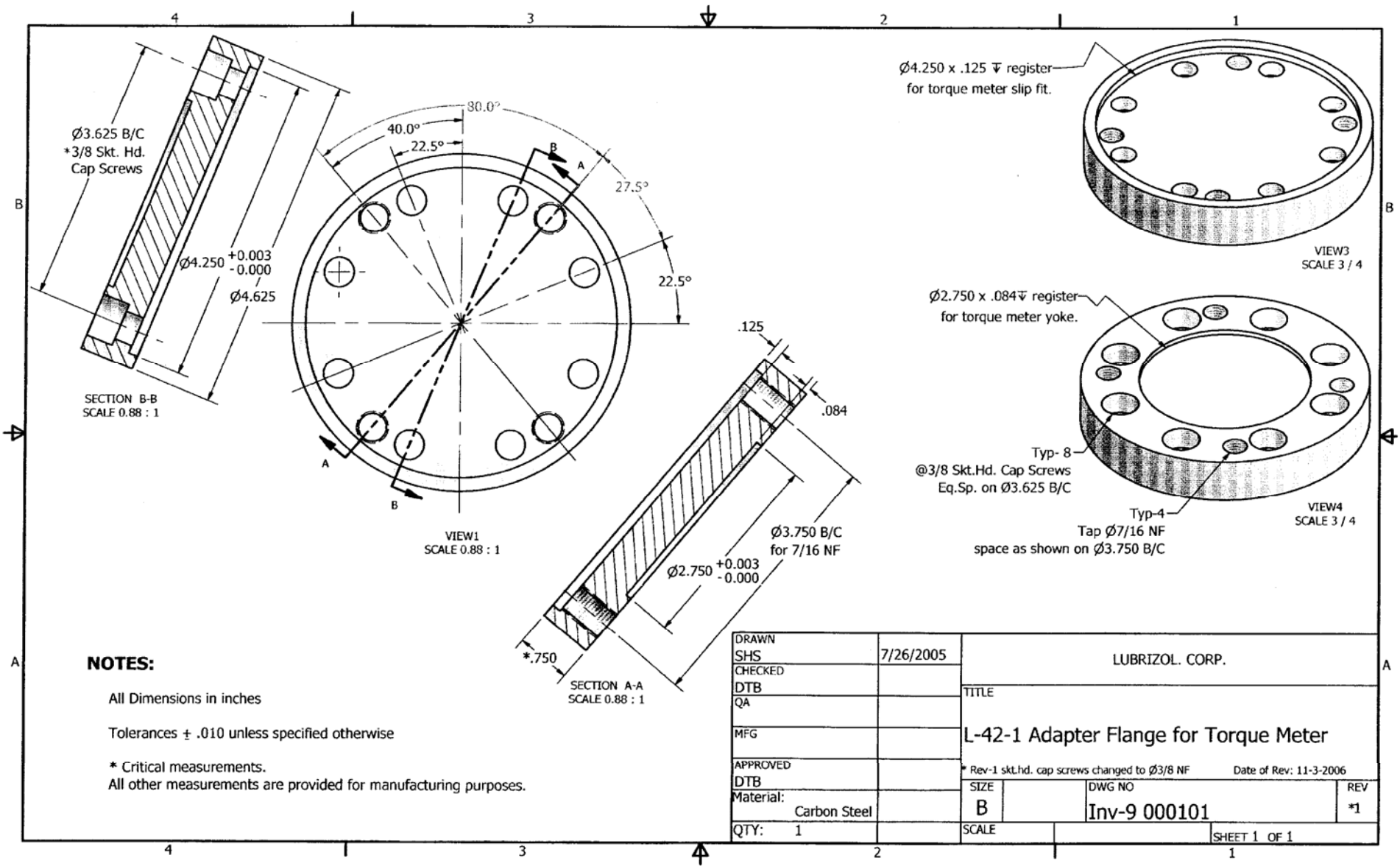

FIG. A2.5 Torque Meter Adapter Flange

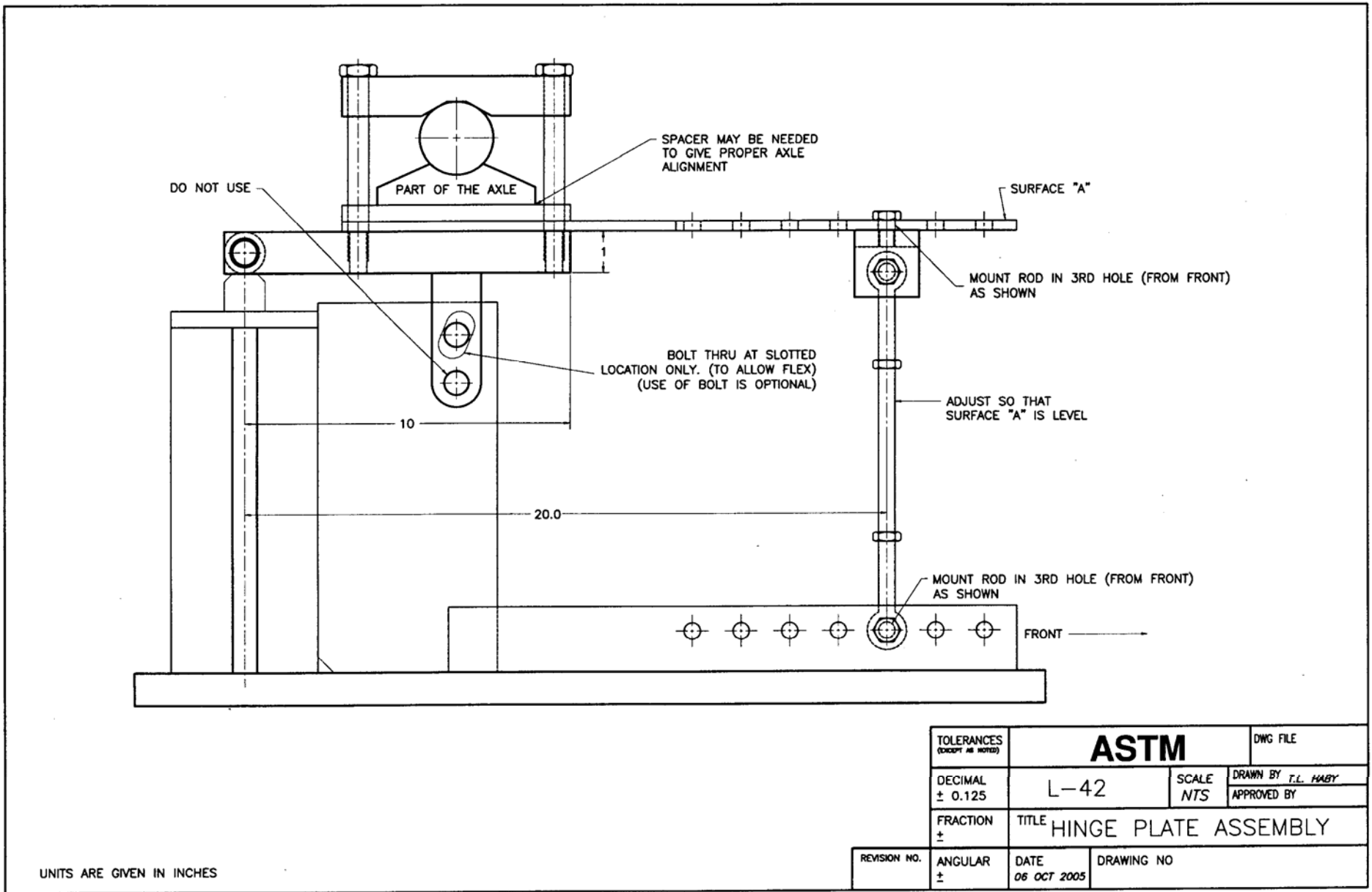
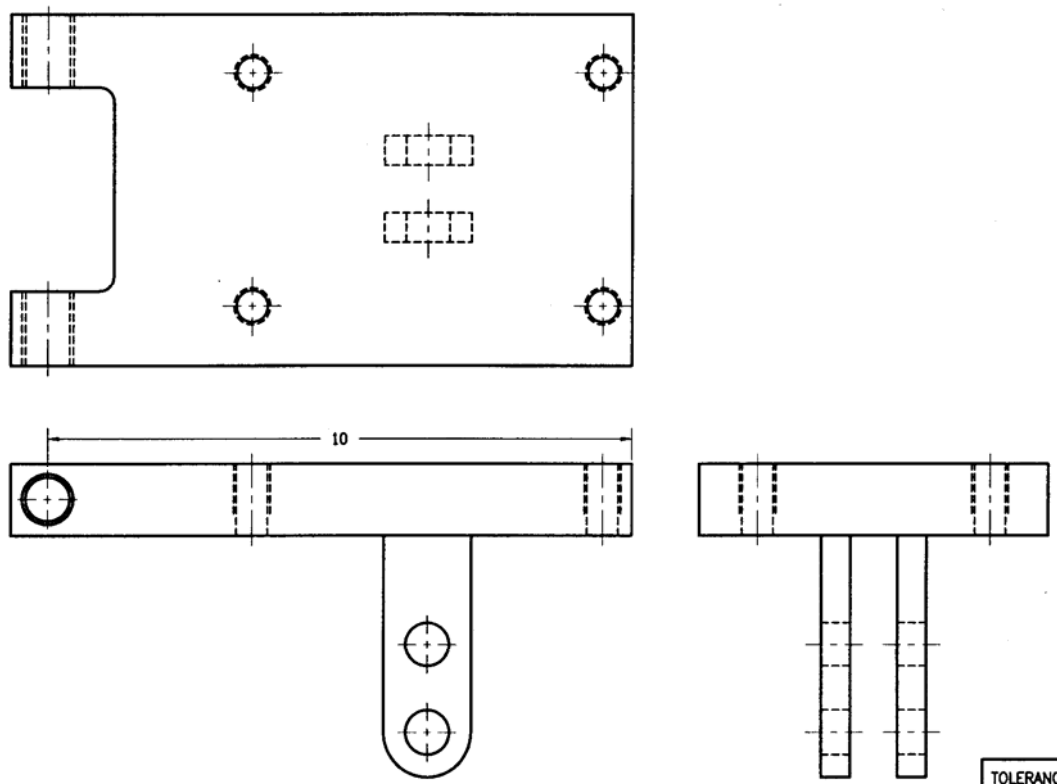

FIG. A2.6 Hinge Plate Stand Assembly



UNITS ARE GIVEN IN INCHES

TOLERANCES (EXCEPT AS NOTED)		ASTM		DWG FILE
DECIMAL ± 0.125	L-42	SCALE NTS	DRAWN BY <i>T.L. HADY</i>	
FRACTION ±	TITLE HINGE PLATE			
REVISION NO.	ANGULAR ±	DATE 08 OCT 2005	DRAWING NO	

FIG. A 2.7 Hinge Plate

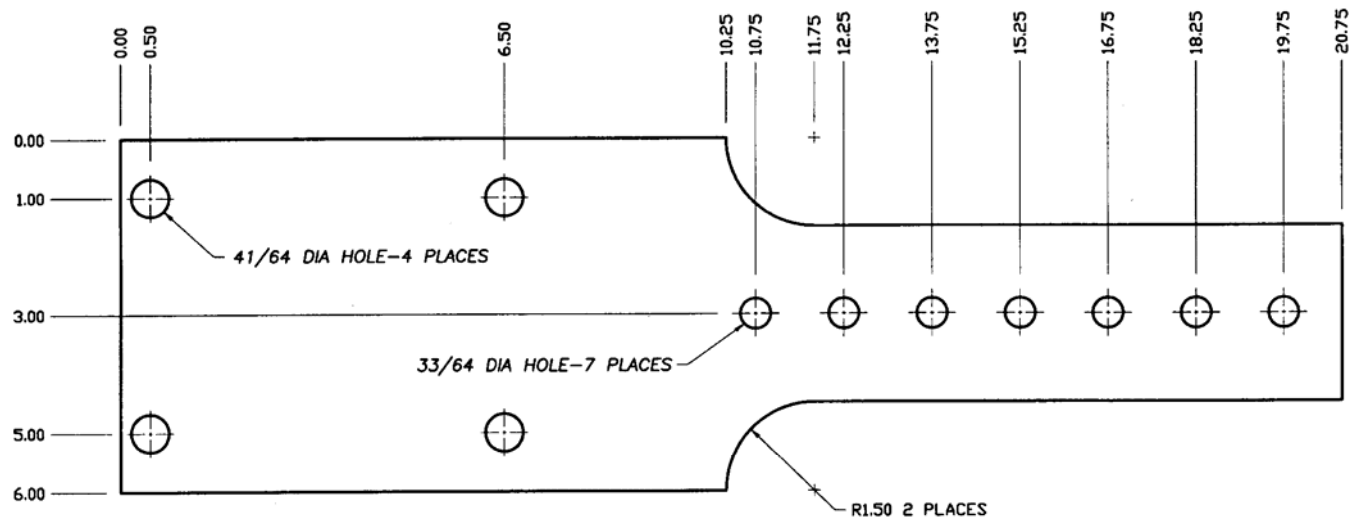

NOTE: MATERIAL-5/16 THICK SAE 1074 STEEL
 SPRING TEMPER RC 42-46

UNITS ARE GIVEN IN INCHES

TOLERANCES (EXCEPT AS NOTED)		ASTM		DWG FILE
DECIMAL ± 0.010	L-42	SCALE NTS	DRAWN BY T.L. HABY MATERIAL	
FRACTION ±	TITLE SPRING PLATE			
REVISION NO.	ANGULAR ±	DATE 08 OCT 2005	DRAWING NO	

FIG. A2 8 Spring Plate

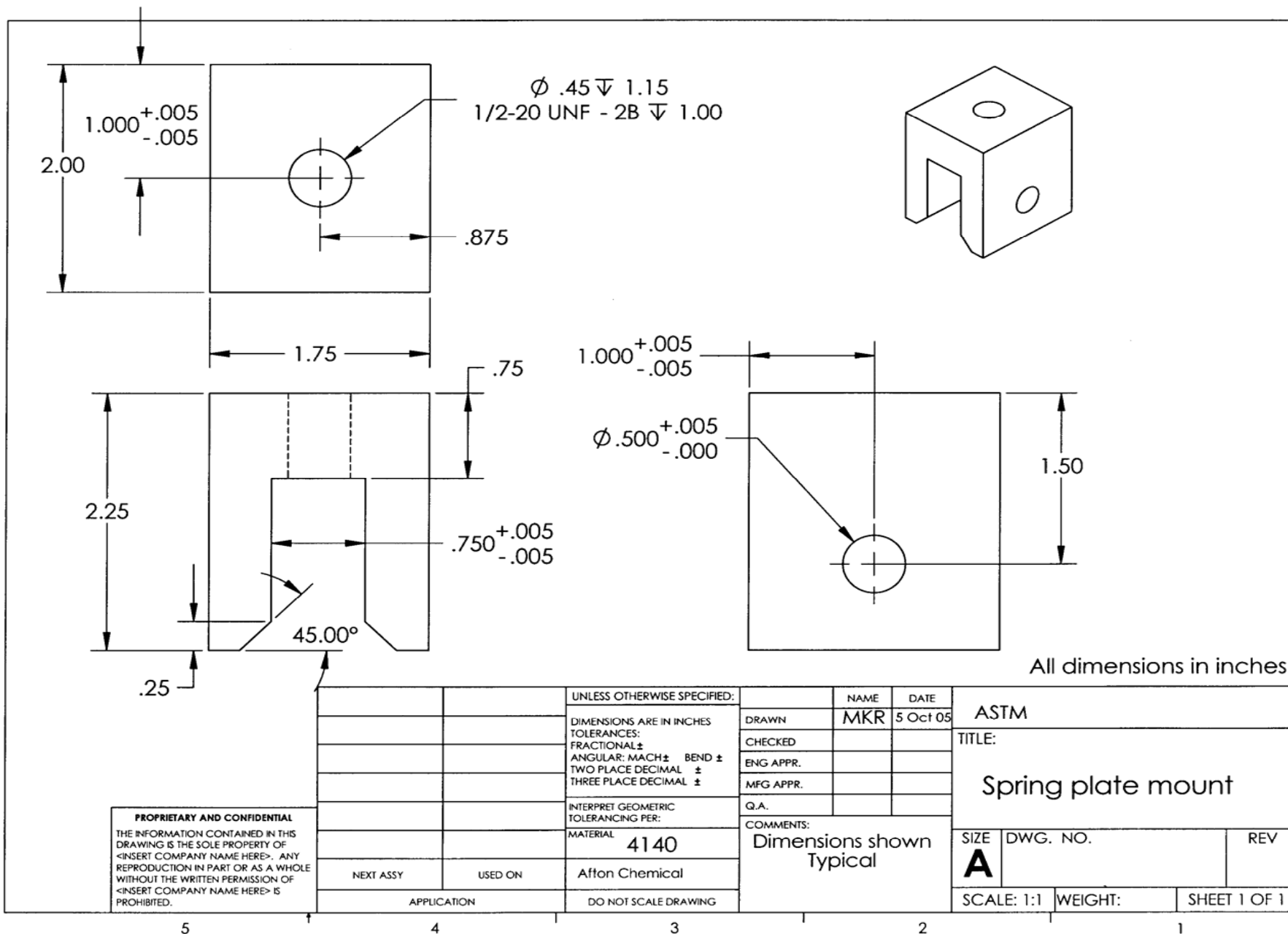

FIG A2.9 Spring Plate Mount

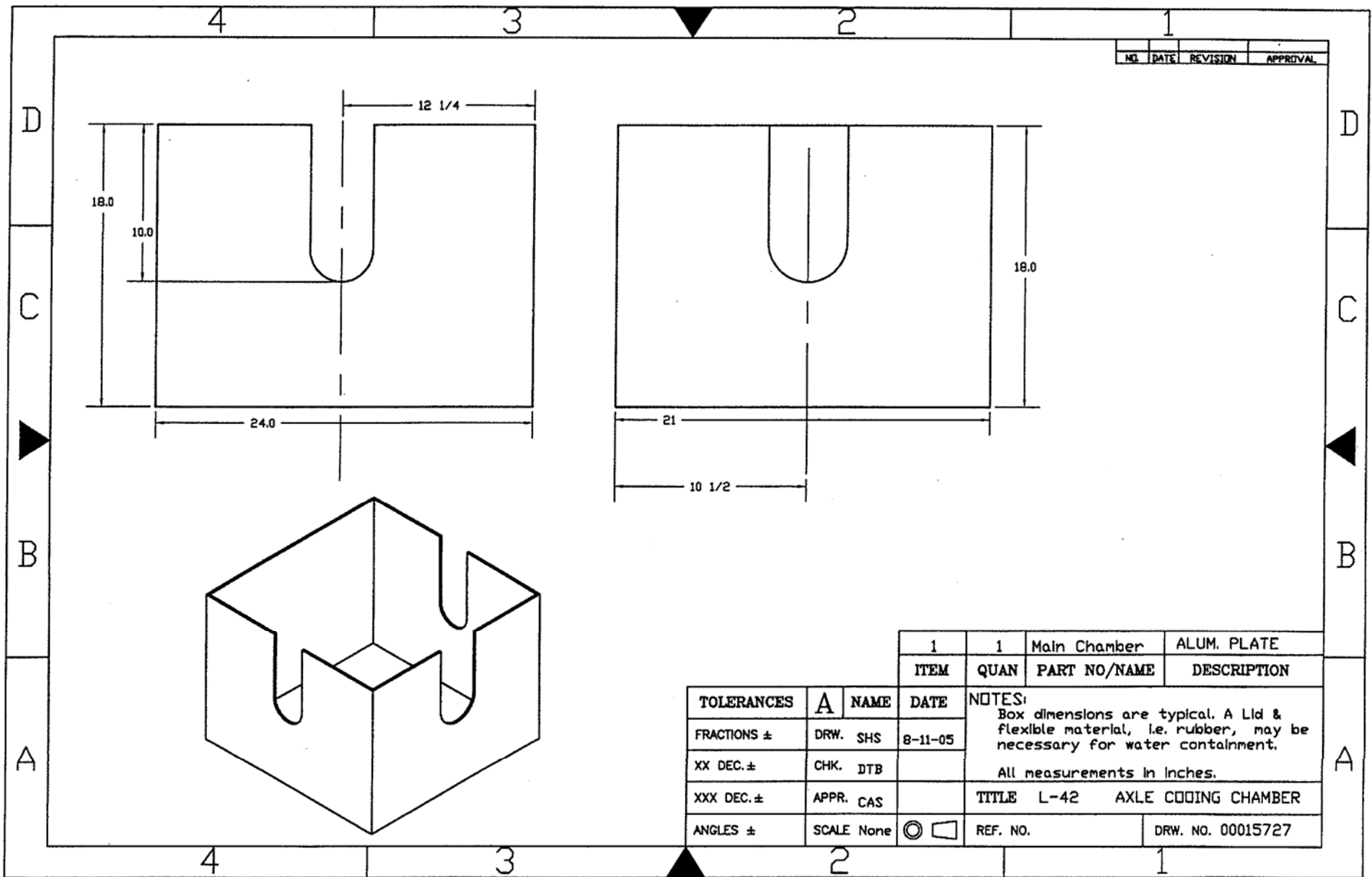

FIG A2.10 Axle Containment Box

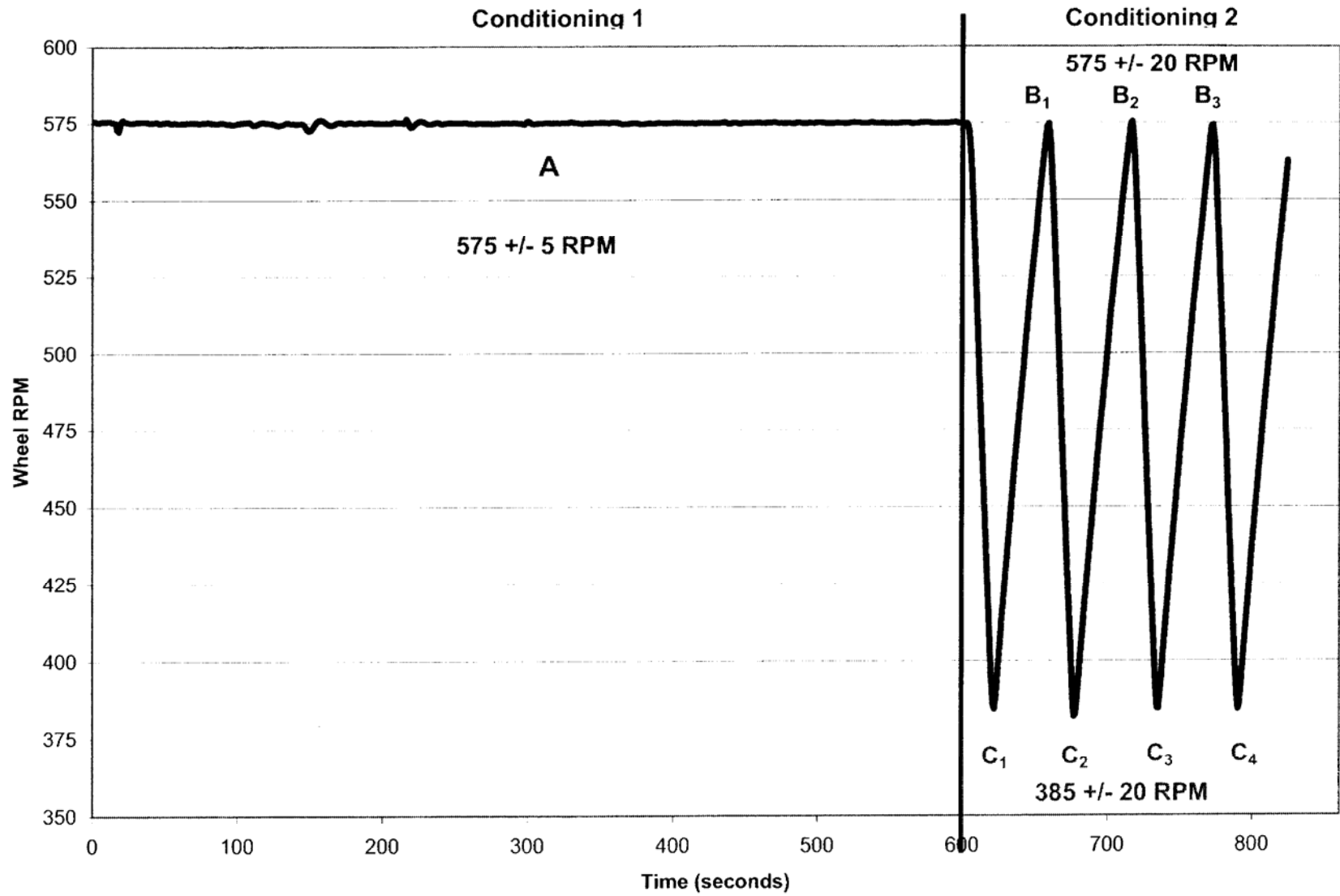

FIG. A2.11 Conditioning 1 & 2 - Wheel Speed

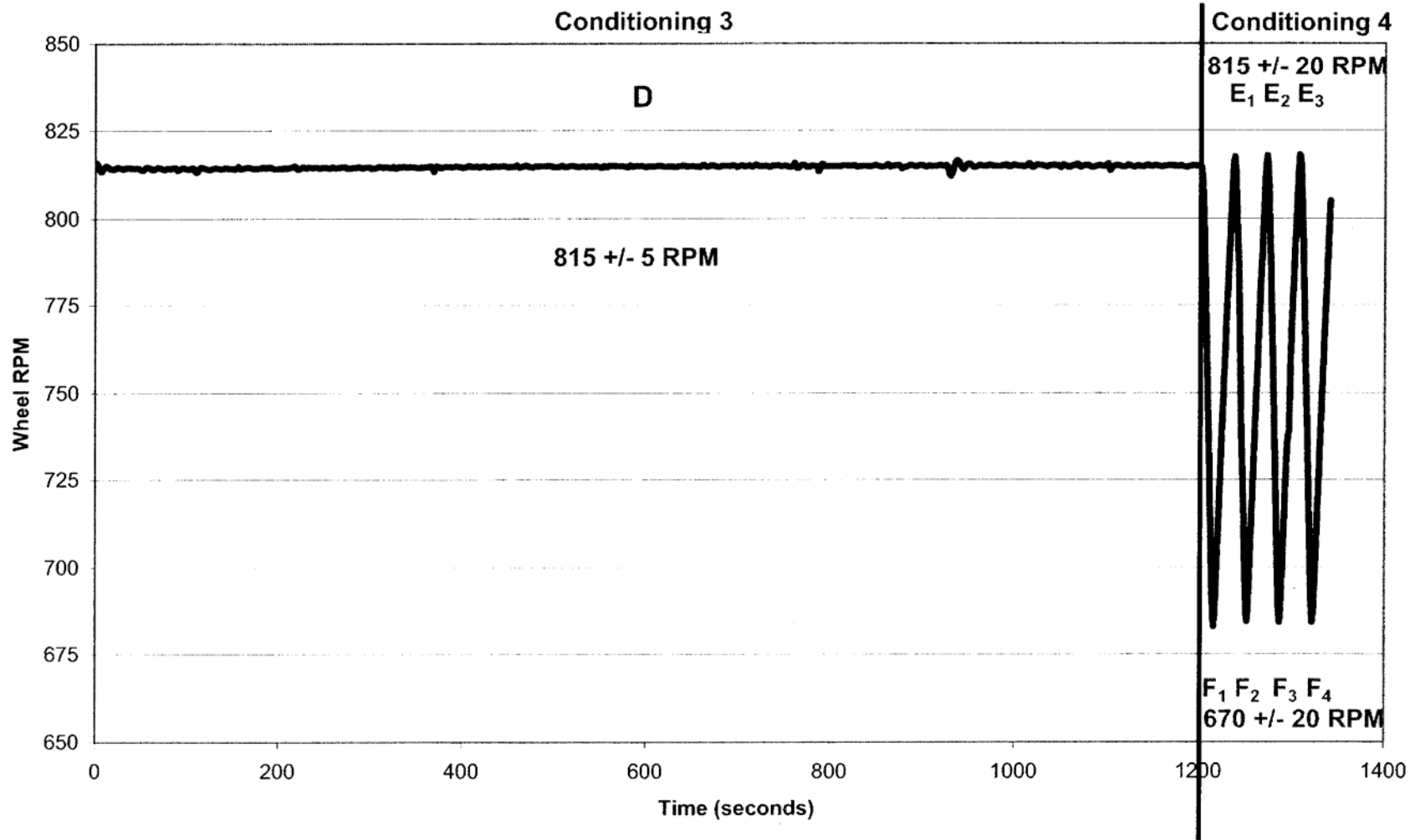

FIG. A2.12 Conditioning 3 & 4 - Wheel Speed

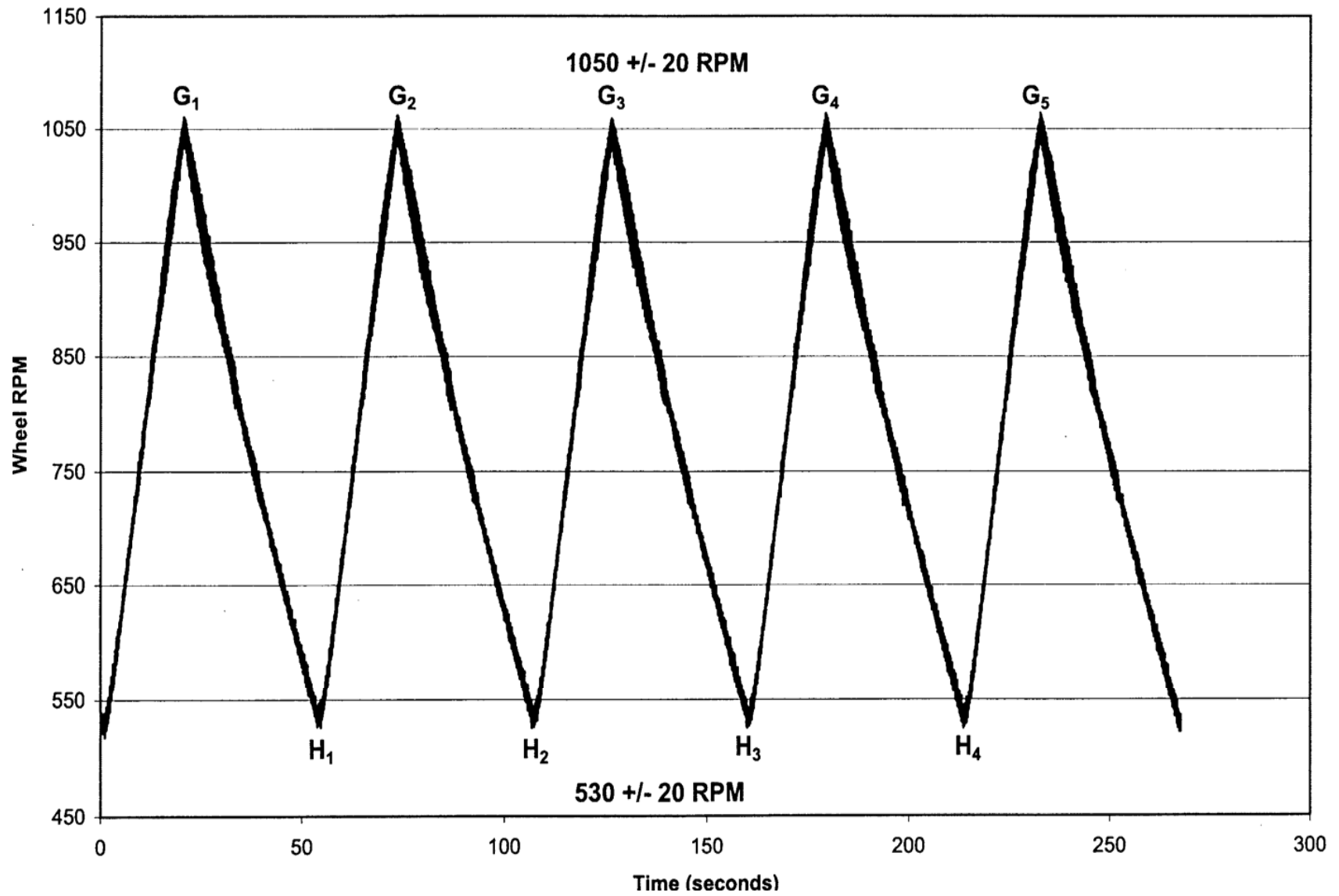

FIG. A2.13 Shock Series One - Wheel Speed (5 Shocks)

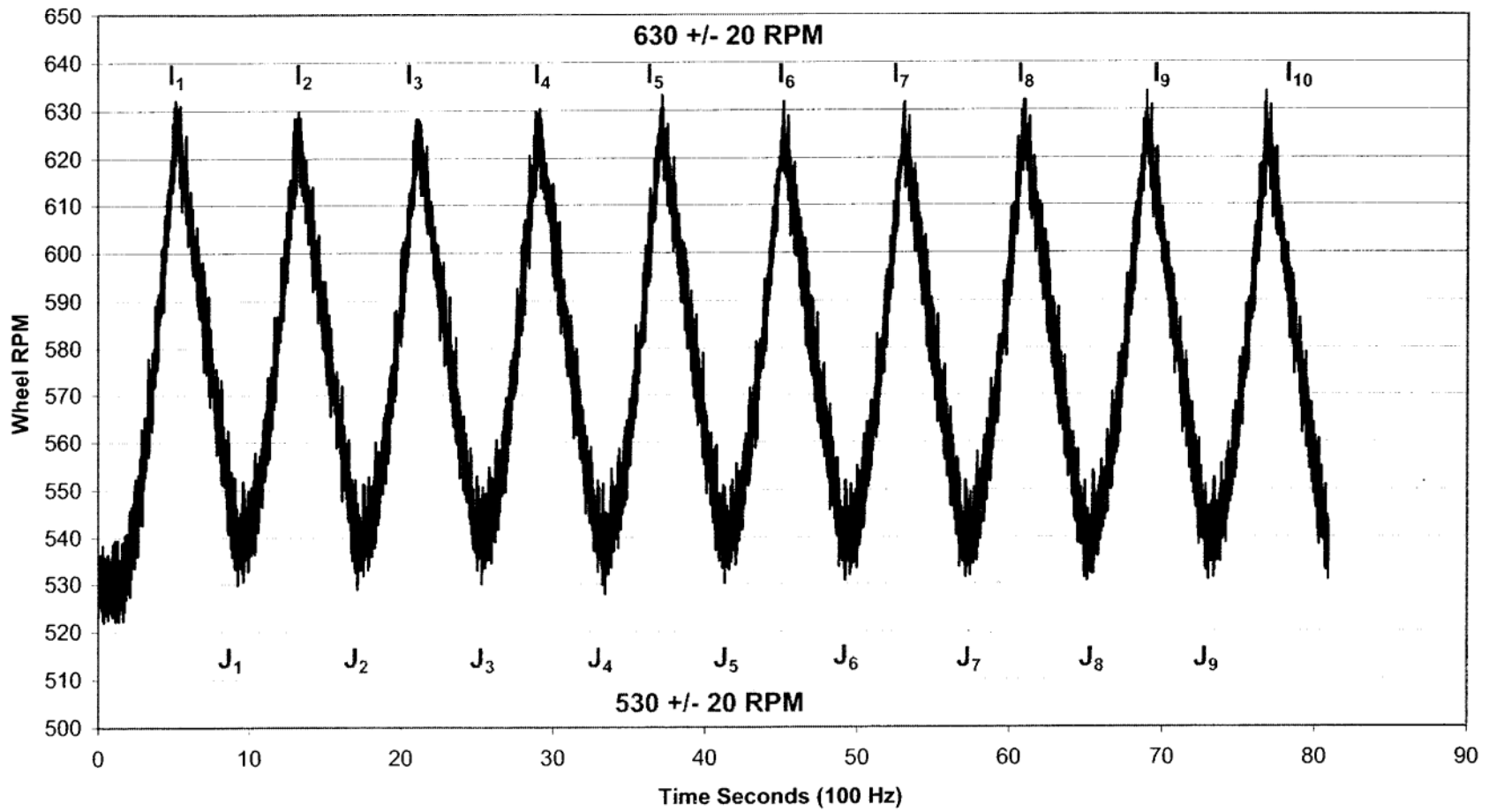

FIG. A2.14 Shock Series Two - Wheel Speed (10 Shocks)

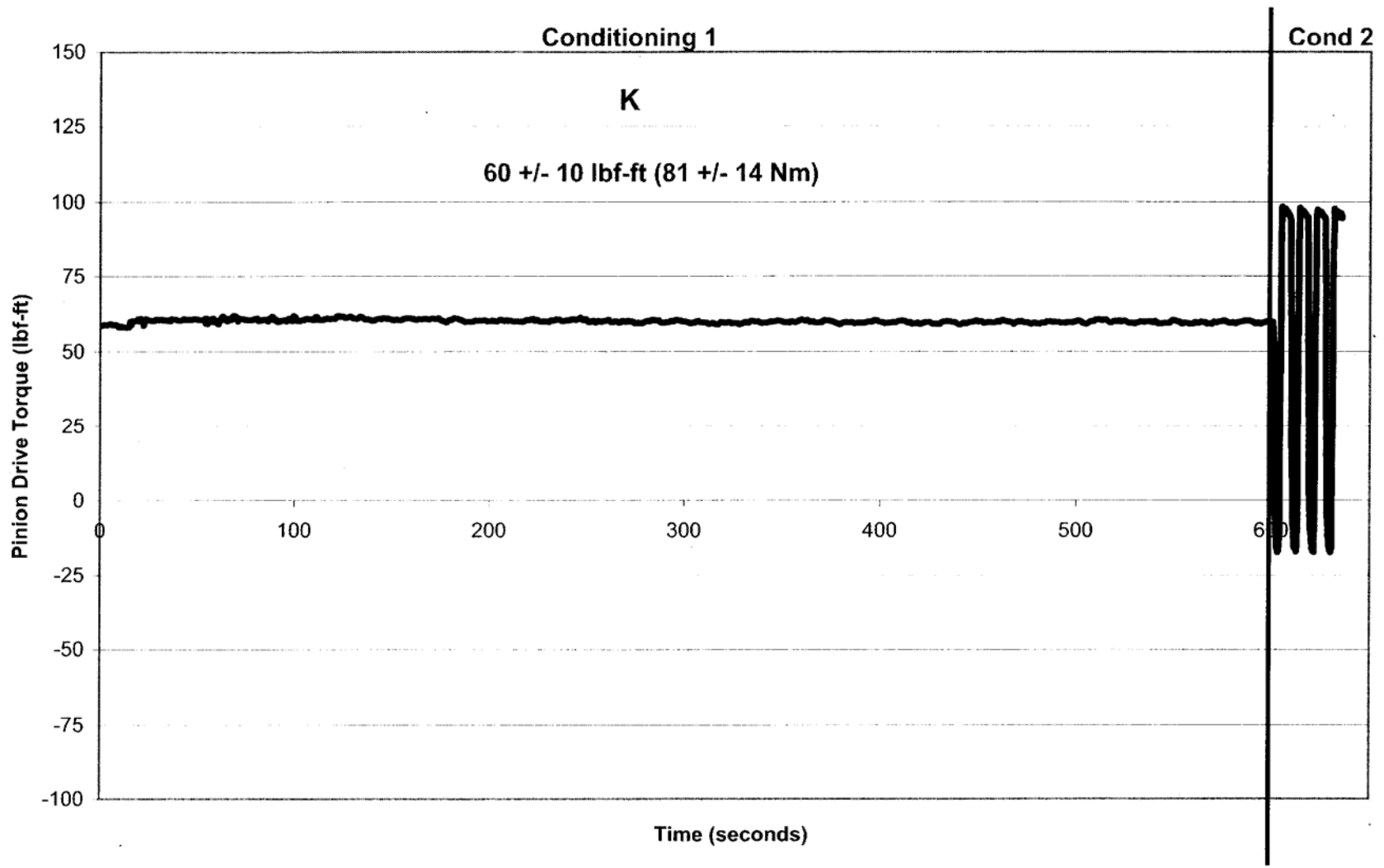

FIG. A2.15 Conditioning 1 & 2 – Pinion Torque

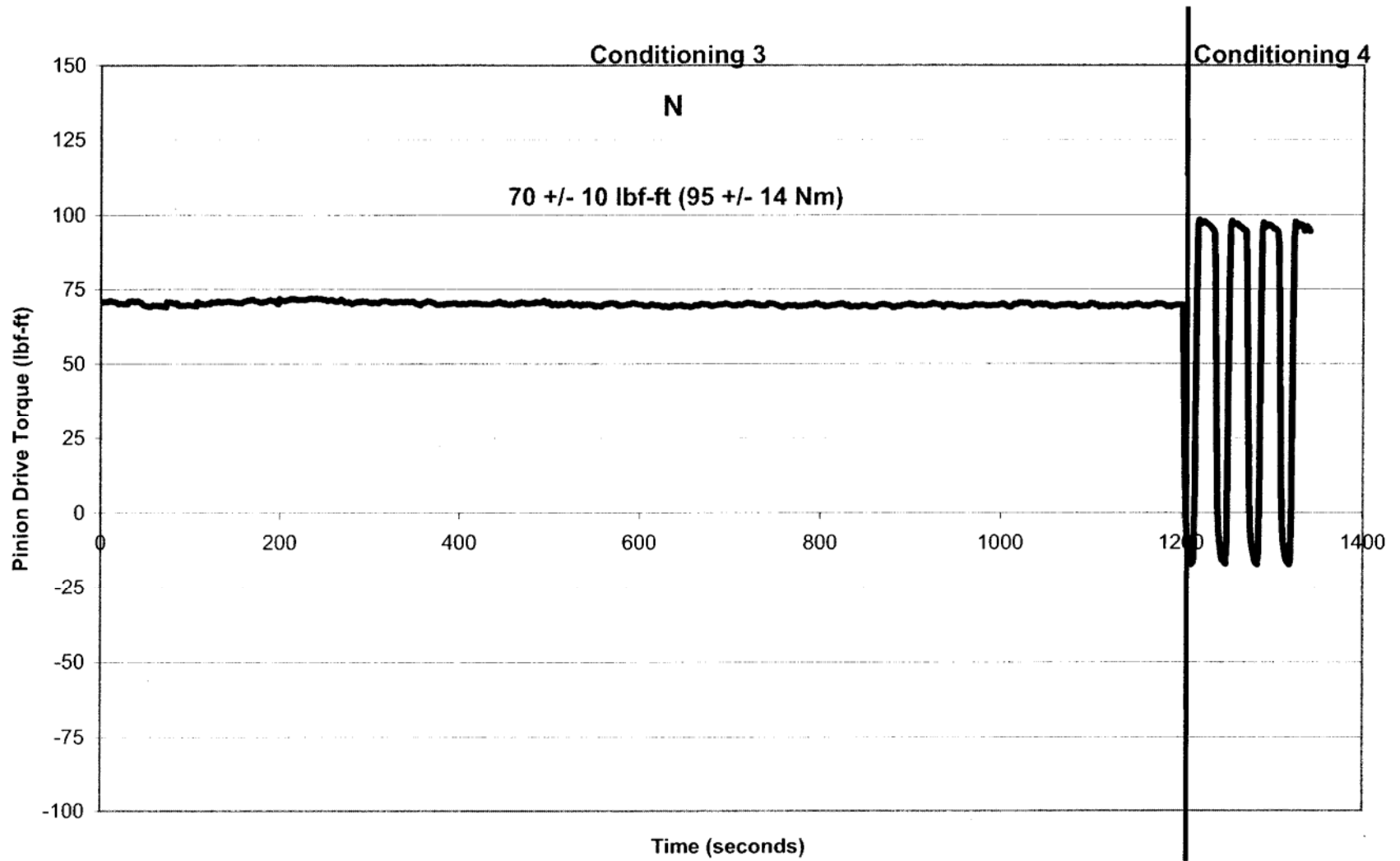

FIG. A2.16 Conditioning 3 & 4 – Pinion Torque

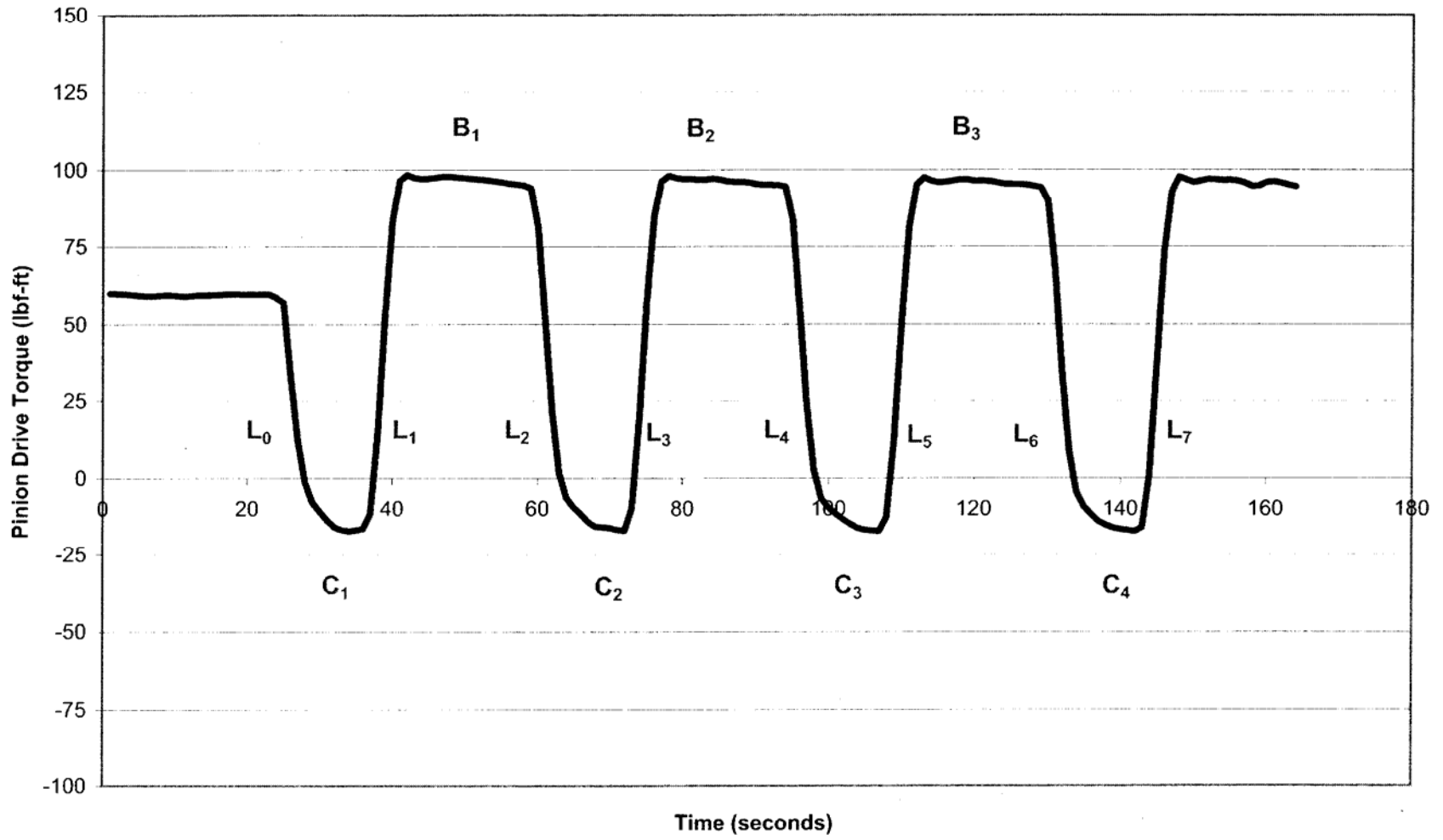

FIG. A2.17 Conditioning 2 – Pinion Torque (Exploded View)

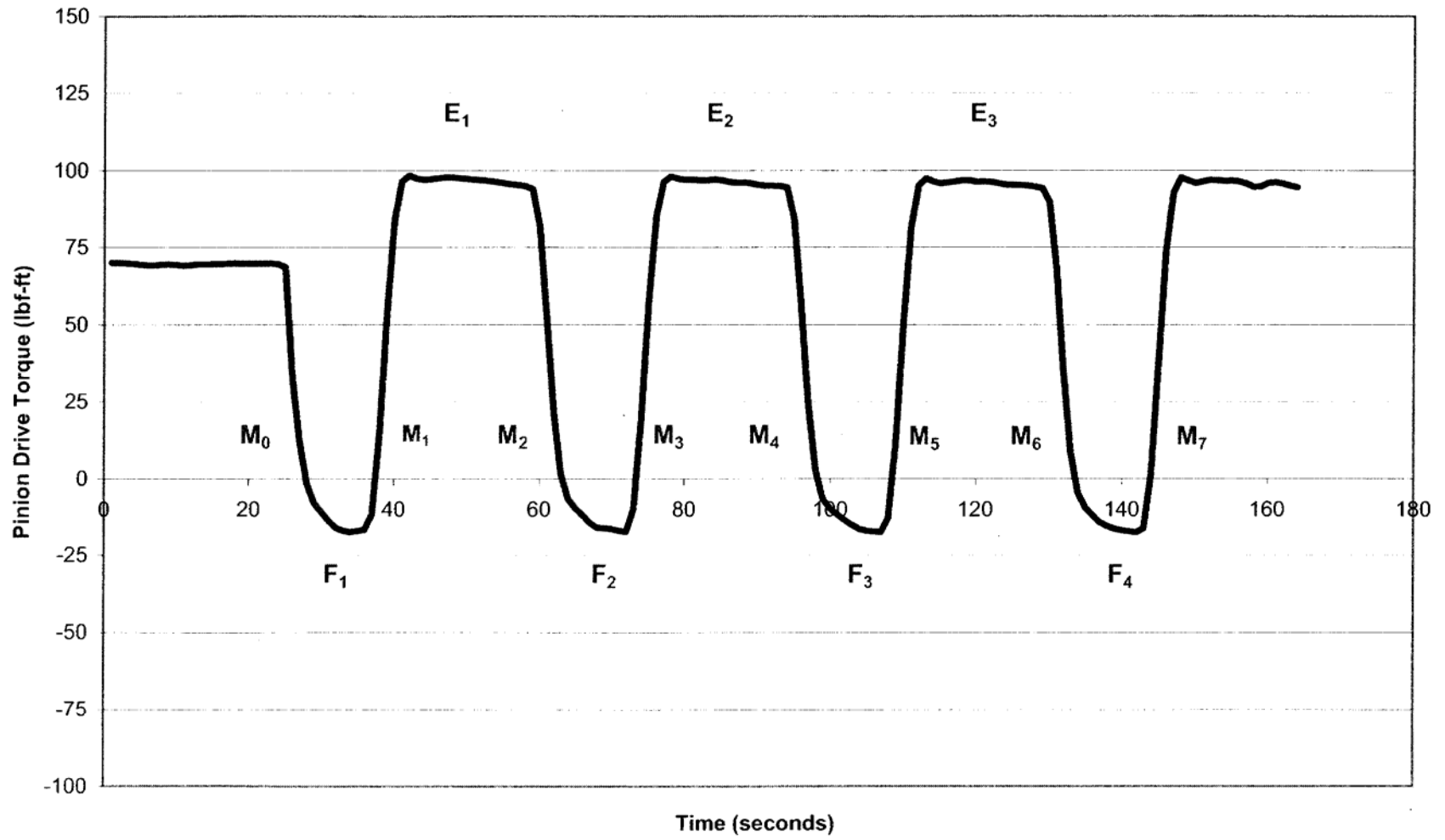

FIG. A2.18 Conditioning 4 – Pinion Torque (Exploded View)

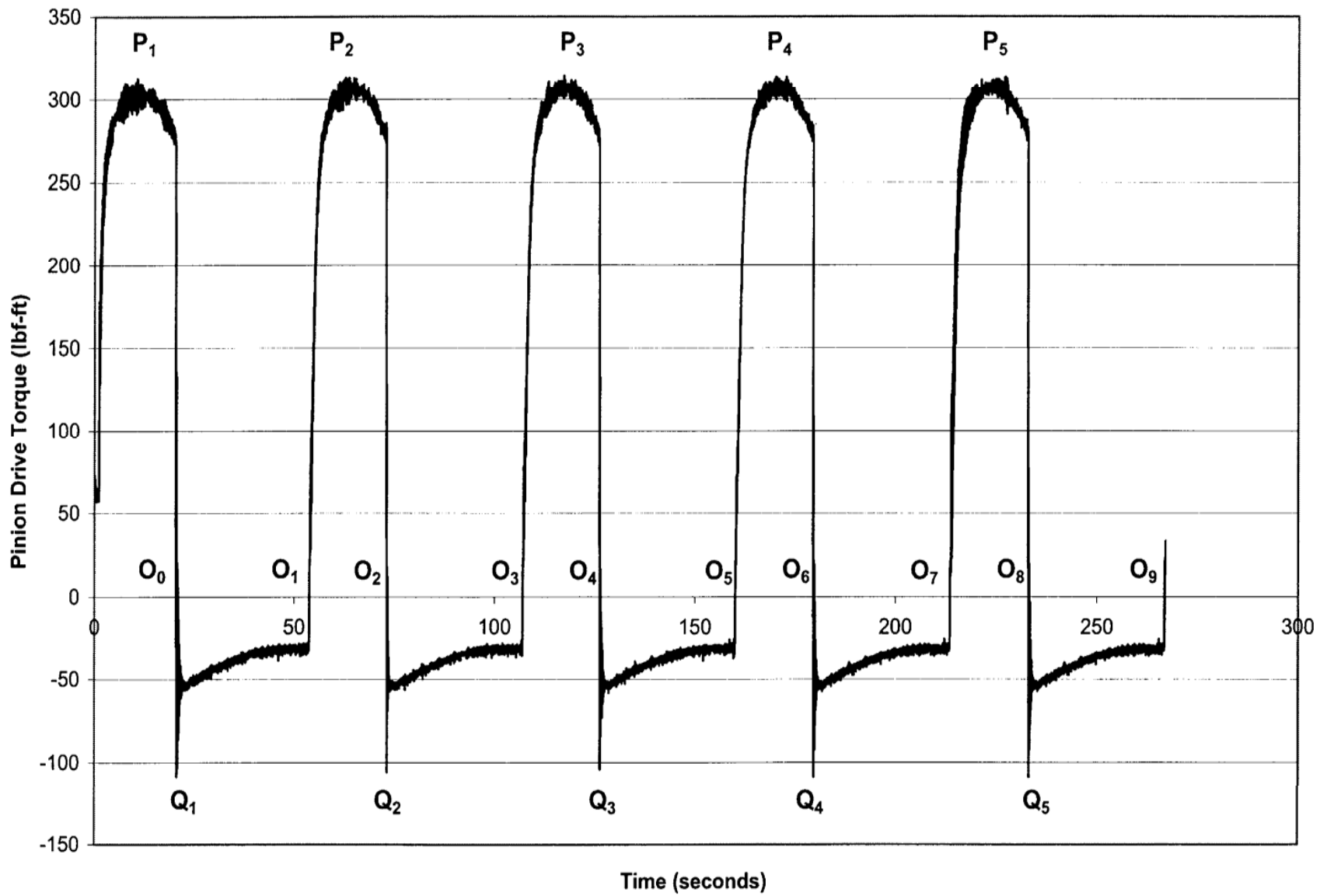

FIG. A2.19 Shock Series One – Pinion Torque (5 Shocks)

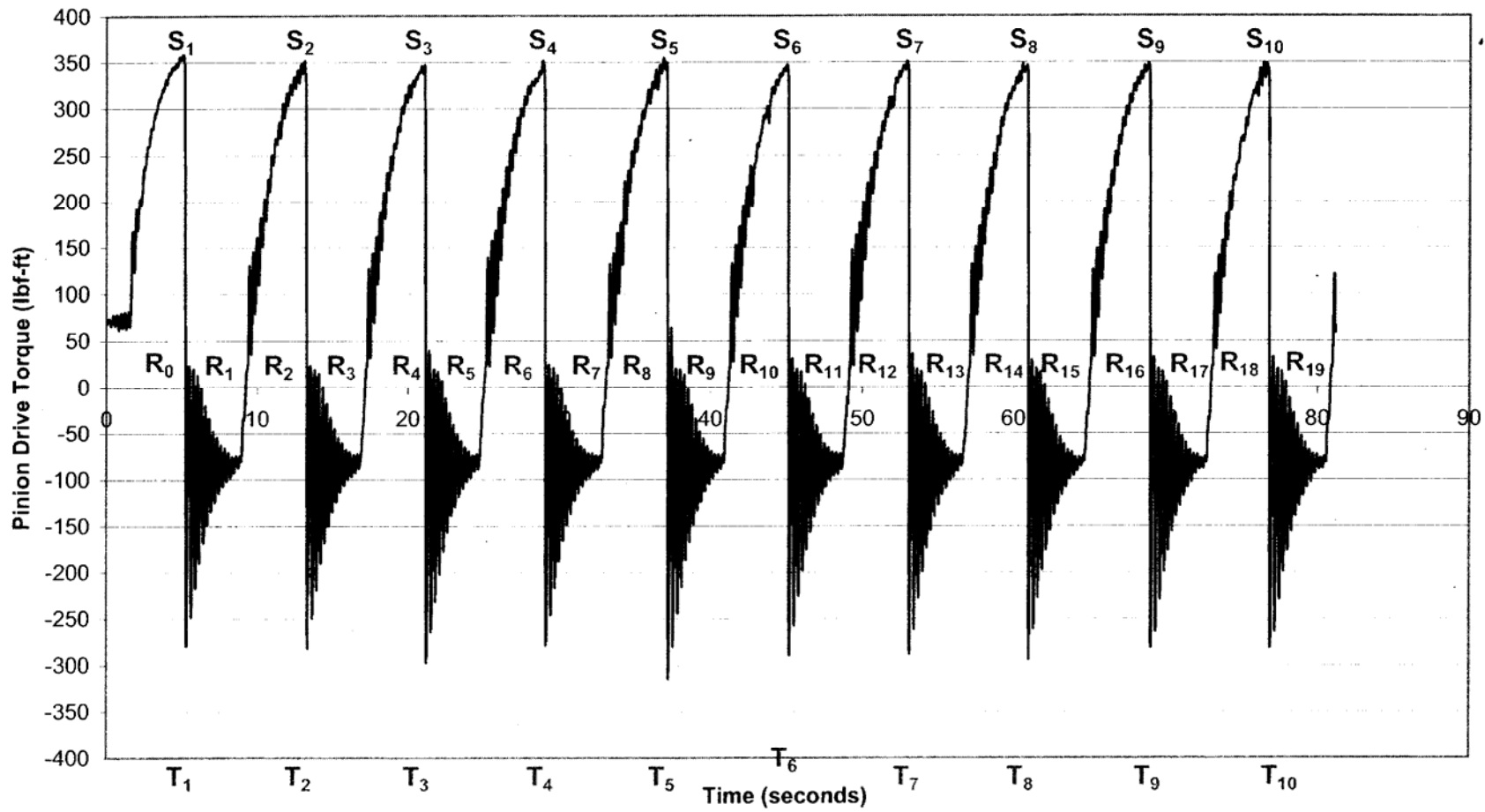

FIG. A2.20 Shock Series Two - Pinion Torque (10 Shocks)



FIG. A2.21 Axle Oil Temperature

A3. L-42 TEST REPORT FORMS and DATA DICTIONARY

The required report forms and data dictionary are available on the ASTM Test Monitoring Center Web Page at <http://astmtmc.cmu.edu/> or can be obtained in hardcopy format from the TMC.

Form 0	Test Report Cover
Form 1	Test Result Summary Page
Form 2	Conditioning Phase Operational Data Summary Sheet
Form 3	Shock Series Operational Data Summary Sheet
Form 4	Measurement Summary Sheet
Form 5	Down Time and Comments Sheet
Form 6	Conditioning Phases 1 & 2 – Wheel Speed vs. Time Graph
Form 7	Conditioning Phases 3 & 4 – Wheel Speed vs. Time Graph
Form 8	Shock Series 1 – Wheel Speed vs. Time Graph
Form 9	Shock Series 2 – Wheel Speed vs. Time Graph
Form 10	Conditioning Phases 1 & 2 – Pinion Torque vs. Time Graph
Form 11	Conditioning Phases 3 & 4 – Pinion Torque vs. Time Graph
Form 12	Conditioning Phase 2 – Pinion Torque vs. Time Graph (Exploded View)
Form 13	Conditioning Phases 4 – Pinion Torque vs. Time Graph (Exploded View)
Form 14	Shock Series 1 – Pinion Torque vs. Time Graph (5 shocks)
Form 15	Shock Series 2 – Pinion Torque vs. Time Graph (10 shocks)
Form 16	Axle Oil Temperature Graph

A4. THE ROLE OF THE ASTM TEST MONITORING CENTER AND THE CALIBRATION

PROGRAM

A4.1 Nature and Functions of the ASTM TMC-The ASTM TMC is a non-profit organization located in Pittsburgh, PA and is staffed to administer engineering studies; conduct laboratory visits; perform statistical analyses of reference oil test data; blend, store, and ship reference oils; and provide the associated administrative functions to maintain the referencing calibration program for various lubricant tests as directed by Subcommittee D02.B and the Test Monitoring Board. The TMC coordinates its activities with the test sponsors, the test developers, the surveillance panels, and the testing laboratories.

A4.2 Rules of Operation of the ASTM TMC-The TMC operates in accordance with the ASTM Charter, the ASTM Bylaws, the Regulations Governing ASTM Technical Committees, the Bylaws Governing ASTM Committee D-2, and the Rules and Regulations Governing the ASTM Test Monitoring System.

A4.3 Management of the ASTM TMC-The management of the Test Monitoring System is vested in the Test Monitoring Board (TMB) elected by Subcommittee D02.B. The TMB selects the TMC Administrator who is responsible for directing the activities of the TMC staff.

A4.4 Operating Income of the ASTM TMC-The TMC operating income is obtained from fees levied on the reference oils supplied and on the calibration tests conducted. Fee schedules are established and reviewed by Subcommittee D02.B.

A4.5 Conducting a Reference Oil Test:

A4.5.1 For those laboratories which choose to utilize the services of the ASTM TMC in maintaining calibration of test stands, full-scale calibration testing are conducted at regular intervals. These full-scale tests are conducted using coded reference oils supplied by the ASTM TMC. It is a laboratory's responsibility to maintain the calibration in accordance with the test procedure. It is also a laboratory's responsibility to keep the on-site reference oil inventory at or above the minimum level specified by the TMC test engineers.

A4.5.2 When laboratory personnel decide to run a reference calibration test, they shall request an oil code from the responsible TMC engineer. Upon completion of the reference oil test, the data are sent in summary form (use TMC-acceptable forms) to the TMC by the ASTM Data Communications Committee Electronic Test Report Transmission Model, or by some other method acceptable to the TMC. The TMC will review the data and contact the laboratory engineer to report the laboratory's calibration status. Report all reference oil tests, whether aborted, invalidated, or successfully completed, to the TMC. Subsequent to sending the data in summary form to the TMC, the laboratory is required to submit to the TMC the written test report specified in the test procedure.

A4.6 New Laboratories-Laboratories wishing to become a part of the ASTM Test Monitoring System will be requested to conduct reference oil tests to ensure that the laboratory is using the proper testing techniques. Information concerning fees, laboratory inspection, reagents, testing practices, appropriate committee membership, and rater training can be obtained by contacting the TMC Administrator at ASTM Test Monitoring Center, 6555 Penn Ave. Pittsburgh, PA 15206.

A4.7 Introducing New L-42 Reference Oils-The calibrating reference oils produce various scoring characteristics. When new reference oils are selected, member laboratories will be requested to conduct their share of tests to enable the TMC to establish the proper industry average and test acceptance limits. The ASTM D02.B0.03 L-42 Surveillance Panel requires a minimum of five tests to be conducted prior to establishing the industry average and test acceptance targets for new reference oils.

A4.8 TMC Information Letters:

A4.8.1 Occasionally, it is necessary to change the procedure, and notify the test laboratories of the change, prior to consideration of the change by either ASTM Subcommittee D02.B on Automotive Lubricants or ASTM Committee D-2 on Petroleum Products and Lubricants. In such a case, the TMC will issue an Information Letter. Subsequently, prior to each semi-annual Committee D-2 meeting, the accumulated Information Letters are balloted by ASTM Subcommittee D02.B. The ballot is reviewed at the ASTM Subcommittee D02.B meeting, and the actions taken are considered at a meeting of ASTM Committee D-2. By this means, the Society due process procedures are applied to these Information Letters.

A4.8.2 The review of an Information Letter prior to its original issue will differ according to its nature. In the case of an Information Letter concerning a part number change which does not affect test results, the TMC is authorized to issue such a letter. Long-term studies by the surveillance panel to improve the test procedure through improved operation and hardware control may result in a recommendation to issue an Information Letter. If obvious procedural items affecting test results need immediate attention, the test sponsor and the TMC will issue an Information Letter and present the background and data to the surveillance panel for approval prior to the semi-annual ASTM Subcommittee D02.B meeting.

A4.8.3 Authority for the issuance of Information Letters was given by the ASTM Committee on Technical Committee Operations (COTCO) in 1984, as follows:

“COTCO recognizes that D-2 has a unique and complex situation. The use of Information Letters is approved providing each letter contains a disclaimer to the effect that such has not obtained ASTM consensus. These Information Letters should be moved to such consensus as rapidly as possible.”

A4.8.4 Information Letters pertaining to this procedure issued prior to 2006-05-01 are incorporated in this test method. A listing of such Information Letters, and copies of the letters, may be obtained from the TMC. Information Letters issued subsequent to this date may also be obtained from the TMC.

A4.9 TMC Memoranda-In addition to the aforementioned Information Letters, supplementary memoranda are issued. These are developed by the TMC, and distributed to the L-42 Test Surveillance Panel and to participating laboratories. They convey such information as batch approvals for test parts or materials, clarification of the test procedure, notes and suggestions for the collection and analysis of special data that the TMC may request, or for any other pertinent matters having no direct effect on the test performance, results, or precision and bias.

4.10 Precision Data-The TMC determines the current L-42 test precision by analyzing results of calibration tests conducted on reference oils. Current precision data can be obtained from the TMC.

A5. TEST VALIDITY CALCULATIONS AND LIMITS

A5.1 For a test to be operationally valid it shall not exceed the limits outlined in this Annex.

A5.2 *Unscheduled shutdowns* – Only one unscheduled shutdown allowed per test. The shutdown can only occur during conditioning 1, conditioning 3, or anytime the driveline is disengaged as allowed or required by the test procedure. Downtime cannot be exceed 15 minutes. Any other unscheduled shutdowns invalidate the test.

A5.3 *Test Length*-Calculate and report total test time starting from the beginning of Conditioning 1 to the end of shock 2. Test length shall not exceed 80 minutes. Downtime is not to be included in the test length time.

A5.4 *Coast Side Torque limits:*

A5.4.1 Non-reference and Discrimination oil test, Shock Series 1 average coast side torque values shall be within $\pm 15\%$ of the average Shock Series1 coast side torque value of the average of the three tests from the most recent operationally and statistically valid reference oil calibration sequence for the test to be considered operationally valid. Each test in a calibration sequence is considered operationally valid if the average Shock Series 1 coast side torque values are within $\pm 15\%$ of the average of the three acceptable calibration sequence tests.

A5.4.2 Non-reference and Discrimination oil test, Shock Series 2 average coast side torque values shall be within $\pm 10\%$ of the average Shock Series 2 coast side torque value of the average of the three tests from the most recent operationally and statistically valid reference oil calibration sequence for the test to be considered operationally valid. Each test in a calibration sequence is considered operationally valid if the average Shock Series 2 coast side torque values are within $\pm 10\%$ of the average of the three acceptable calibration sequence tests.

A5.5 *Deviations From Test Operating Parameters:*

A5.5.1 Axle oil temperature is considered a critical operating parameter during the gear conditioning phase of this test. Axle speed and pinion torque are considered critical operating parameters during the steady state portion of the conditioning phase of the test.

A5.5.2 The percent deviation of these parameters is calculated as follows:

$$\% = \sum \frac{\text{abs}(\text{amount out of specification})}{1/2 \text{ specification range}} \times \frac{\text{out of specification, h}}{\text{test length, h}} \times 100 \quad (\text{A5.1})$$

A5.5.3 The deviation percentages for the critical operating parameters are shown in Table A5.1

A5.5.4 Calculate axle oil temperature percent deviation after 220°F (104.4°C) is reached for the entire conditioning phase of the test.

A5.5.5 Calculate r/min percent deviation after 570 r/min (60 rad/s) is reached for the gear conditioning 1 portion of the test.

A5.5.6 Calculate pinion torque percent deviation after 50 lbf-ft (68 N-m) is reached for the

gear conditioning 1 portion of the test.

A5.5.7 Calculate r/min percent deviation after 810 r/min (85 rad/s) is reached for the gear conditioning 3 portion of the test.

A5.5.8 Calculate pinion torque percent deviation after 60 lbf-ft (81 N-m) is reached for the gear conditioning 3 portion of the test.

Table A5.1 Critical Operating Parameter Limits

	Entire Conditioning Phase	Conditioning Phase 1	Conditioning Phase 3
Parameter	Limits	Limits	Limits
Axle Oil Temperature	5%	-----	-----
Axle Speed	-----	5%	5%

¹ This test method is under the jurisdiction of ASTM Committee D02 on Petroleum Products and Lubricants and is the direct responsibility of Subcommittee D02.B0 on Automotive Lubricants.

² Until the next revision of this test method, the ASTM Test Monitoring Center (TMC) will update changes in this test method by means of information letters. Information letters may be obtained from the ASTM Test Monitoring Center, 6555 Penn Avenue, Pittsburgh, PA 15206, Attention: Administrator. The TMC is also a source of reference oils.

³ For referenced ASTM standards, visit the ASTM website, www.astm.org, or contact ASTM Customer Service at service@astm.org. For *Annual Book of Standards* volume information, refer to the standard's Document Summary page on the ASTM website.

⁴ Available from Society of Automotive Engineers, 400 Commonwealth Drive, Warrendale, PA 15096-0001

⁵ Available from the Coordinating Research Council, 219 Perimeter Center Parkway NE, Atlanta, GA 15096-5094

⁶ Available from Dana Corporation, P.O. Box 2424, Fort Wayne, IN 46801

⁷ Available from the American Petroleum Institute, 1220 L Street NW, Washington, D.C. 20005

⁸ The sole source supply of the apparatus known to the committee at this time is Spray Systems Company, and can be purchased through E.I. Pfaff Company, 3443 Edwards Road, Suite D, Cincinnati, Ohio 45208. Tel: 513-871-9900.

⁹ The sole source supply of the apparatus known to the committee at this time is S. Himmelstein and Company, 2490 Pembroke Avenue, Hoffman Estates, IL 60195

¹⁰ Available from Dyne Systems, P.O. Box 18 W209 N17391 Industrial Drive, Jackson, WI 53037

¹¹ Available from Fox/Jordan, Inc., 5607 West Douglas Avenue, Milwaukee, WI 53218

¹² Available from any local drive shaft supplier.

¹³ The gear marking compound is made by Wayne Metal Working Company, telephone (810) 937-1900.
