



**Address** 100 Barr Harbor Drive  
PO Box C700  
W. Conshohocken, PA  
19428-2959 | USA

**Phone** 610.832.9500  
**Fax** 610.832.9666  
**Web** [www.astm.org](http://www.astm.org)

---

### **Committee D02 on PETROLEUM PRODUCTS AND LUBRICANTS**

*Chairman:* KENNETH O. HENDERSON, Cannon Instrument Co., 2139 High Tech Road, State College, PA 16803, (814) 353-8000, Fax: (814) 353-8007, e-mail: [kenohenderson@worldnet.att.net](mailto:kenohenderson@worldnet.att.net)  
*First Vice-Chairman:* BEN R. BONAZZA, TI Group Automotive Systems, Caro Research Center, 326 Green Street, Caro, MI, 48723 (989) 673-8181 ext. 227, Fax: (989) 673-3241, e-mail: [bbonazza@us.tiauto.com](mailto:bbonazza@us.tiauto.com)  
*Second Vice-Chairman:* JANET L. LANE, ExxonMobil Research & Engrg., 600 Billingsport Rd, Paulsboro, NJ 08066-0480 (856) 224-3302, Fax: (856) 224-3616, e-mail: [janet.l.lane@exxonmobil.com](mailto:janet.l.lane@exxonmobil.com)  
*First Secretary:* RALPH A. CHERRILLO, Shell Global Solutions (US) Inc., Westhollow Tech Ctr., 3333 Highway 6 South, Houston, TX 77082 (281) 544-8789, Fax: (281) 544-8150, e-mail: [ralph.cherrillo@shell.com](mailto:ralph.cherrillo@shell.com)  
*Second Secretary:* MICHAEL A. COLLIER, Petroleum Analyzer Co. LP, PO Box 206, Wilmington, IL 60481, (815) 458-0216, Fax: (815) 458-0217, e-mail: [macvarlen@aol.com](mailto:macvarlen@aol.com)  
*Staff Manager:* DAVID R. BRADLEY, (610) 832-9681, Fax: (610) 832-9668, e-mail: [dbradley@astm.org](mailto:dbradley@astm.org)

May 13<sup>th</sup>, 2021

Reply to:  
Matt Sangpeal  
Afton Chemical Corporation  
500 Spring St.  
Richmond, VA 23219  
(804) 788-5364  
(804) 788-6239 [FAX]  
[matt.sangpeal@aftonchemical.com](mailto:matt.sangpeal@aftonchemical.com)

ASTM D02.B0.03 L-42 Surveillance Panel  
Members and Guests:

Attached for your review and comment are the unconfirmed minutes of the:

**May 12, 2021 L-42 Surveillance Panel Meeting (Virtual Meeting – Microsoft Teams)**

Please direct any corrections or comments to my attention.

Very Respectfully,

Matt Sangpeal, Chairman  
L-42 Surveillance Panel

## L-42 Surveillance Panel Meeting Minutes

Virtual Meeting – Microsoft Teams

May 12, 2021

**Attendees:** voting members in **bold**

**R. Banas (Exxon Mobil)**

S. Bealko (LZ)

**D. Beck (TMC)**

D. Bell (Afton)

**J. Carter (Meritor)**

A. Comfort (US Army)

K. Drlja (LZ)

**A. Goyal (BASF)**

P. Kanga (Exxon Mobil)

J. LaBond (Meritor)

**A. Lange (Intertek)**

D. Moser (BASF)

**T. Muransky (AAM)**

**M. Sangpeal (Afton/C)**

D. Schwenk (Afton)

**R. Slocum (LZ)**

D. Smith (Intertek)

W. Venhoff (LZ)

**R. Warden (SwRI)**

**A. Zyski (Dana)**

### **Call to Order**

#### **Review of Agenda**

The meeting agenda is attached.

#### **Review of Membership**

No changes were necessary.

#### **Approval of Meeting Minutes**

Meeting minutes for approval:

- "20210210\_SP" → February 10, 2021 – Virtual Surveillance Panel Meeting – Microsoft Teams

A motion was made to approve these meeting minutes as presented.

Motion: J. Carter

Second: T. Muransky

All in favor, no objections, no abstentions.

### **L-42-1 Development**

R. Warden presented progress on electric L-42 test development (see graphs below). The motor currently installed has a 2300 RPM limit (~610 Wheel RPM). The current VFD requires modification to reliably achieve Shock 2 conditions.

Next steps will be to install a 3600 RPM base speed motor and add a braking resistor to help control Shock 2. This should allow use of existing eddy current dynos and non-regenerative drive. It would also not require absorbing motors to be installed.

No hardware donation is needed at this time.

### **L-42 Proposed Report Change**

D. Beck proposed that Rater Calibration Expiration Dates should be added to all L-42 test reports. Currently, only raters' initials are recorded. This would provide an additional check to ensure that the rater is within their RCMS calibration period when rating test parts.

A motion was made to change the test report to include Rater Calibration Expiration Date, effective 7/16/21.

Motion: R. Warden

Second: W. Venhoff

All in favor, no objections, no abstentions.

### **New Hardware Order**

M. Sangpeal reviewed the status of Afton's L-42 hardware order. He shared that there are now additional delays with the raw steel supplier. The order is delayed until June, 2021.

Dana has proposed moving the vent hole location from the left side of the axle to the right. The tubes have already been drilled in this manner. The panel concluded that this change would likely have no effect on test results and decided to allow it. No vote was deemed necessary, as the L-42 is a self-referencing test, so any batch to batch difference would already be accounted for.

### **L-42 Hardware Print Review**

044AA100 (axle assembly) and ASTM Assembly Requirements WIENG00001/1 were presented. M. Sangpeal requested most recent drawings from Dana for committee review, waiting to hear back.

A. Zyski stated that she would help acquire any available drawings from within Dana.

### **New/Open Issues**

No new issues.

### **Adjournment**

A motion was made to adjourn.

Motion: A. Zyski

Second: R. Warden

All in favor, no objections, no abstentions.

Meeting adjourned.

Respectfully submitted,

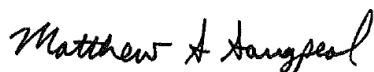

Matt Sangpeal

L-42 Surveillance Panel Chairman



# L-42 Surveillance Panel Meeting

ASTM D7452

Virtual Meeting

May 12, 2021

1:00 pm – 2:00 pm EST

Passion for Solutions™

# Agenda

-  **Call to Order**
-  **Agenda**
-  **Membership Review & Update**
-  **Approval of Meeting Minutes**
  -  20210210 Virtual SP Meeting
-  **L-42-1 Development**
  -  Testing development updates
  -  Hardware donation
-  **L-42 Proposed Report Change**
-  **2020 Hardware Order Update**
  -  Proposed vent location change
-  **L-42 Hardware Print Review**
-  **New Issues**
-  **Adjournment**



*Passion for Solutions™*

## L-42 SP Voting Members

 Rob Banas:	ExxonMobil
 Dylan Beck:	TMC
 Mike Cabaj:	Linamar
 Allen Comfort:	US Army
 Arjun Goyal:	BASF
 Troy Muransky:	AAM
 Jason Carter:	Meritor
 Matt Sangpeal:	Afton Chemical (Chair)
 Robert Slocum:	Lubrizol
 Anthony Lange:	Intertek
 Rebecca Warden:	SwRI
 Amy Zyski:	Dana

# Approval of Meeting Minutes

## SP Meeting Minutes

- ▲ “20210210\_SP” → February 10, 2021 – Virtual Surveillance Panel Meeting – Microsoft Teams

# Electric L-42 Development

SOUTHWEST RESEARCH INSTITUTE®



---

FUELS & LUBRICANTS RESEARCH

©SOUTHWEST RESEARCH INSTITUTE

[swri.org](http://swri.org)



# Electric L-42 Test Stand



## Limitations and Plans

- Currently installed motor has 2300 rpm limit (approximately 610 rpm wheel speed)
- Currently installed VFD requires modifications to reliably achieve conditions required for Shock 2
  
- In process
  - installation of 3600 rpm base speed motor
  - Purchasing braking resistor for shock 2



## Conditioning 2, Pinion Torque

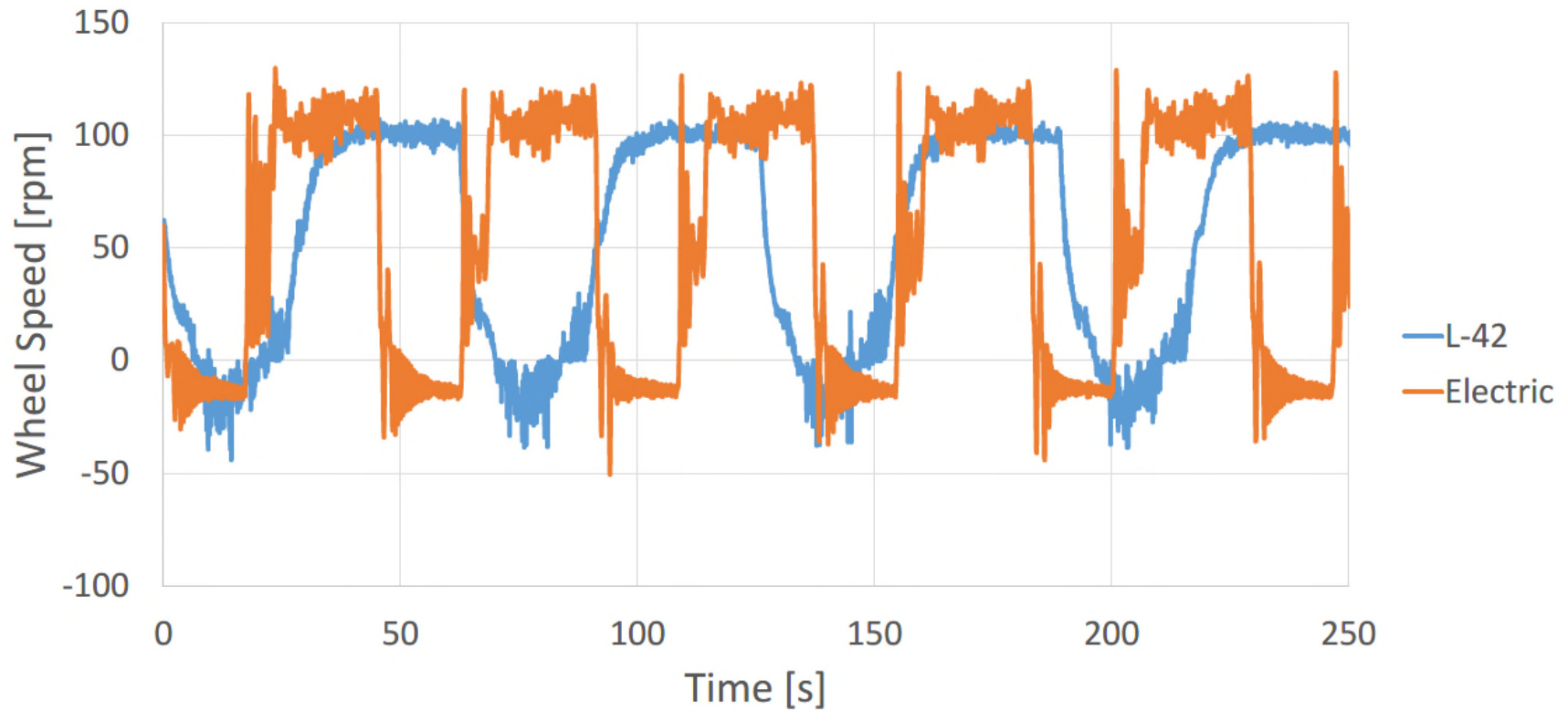

# Conditioning 2, Wheel Speed

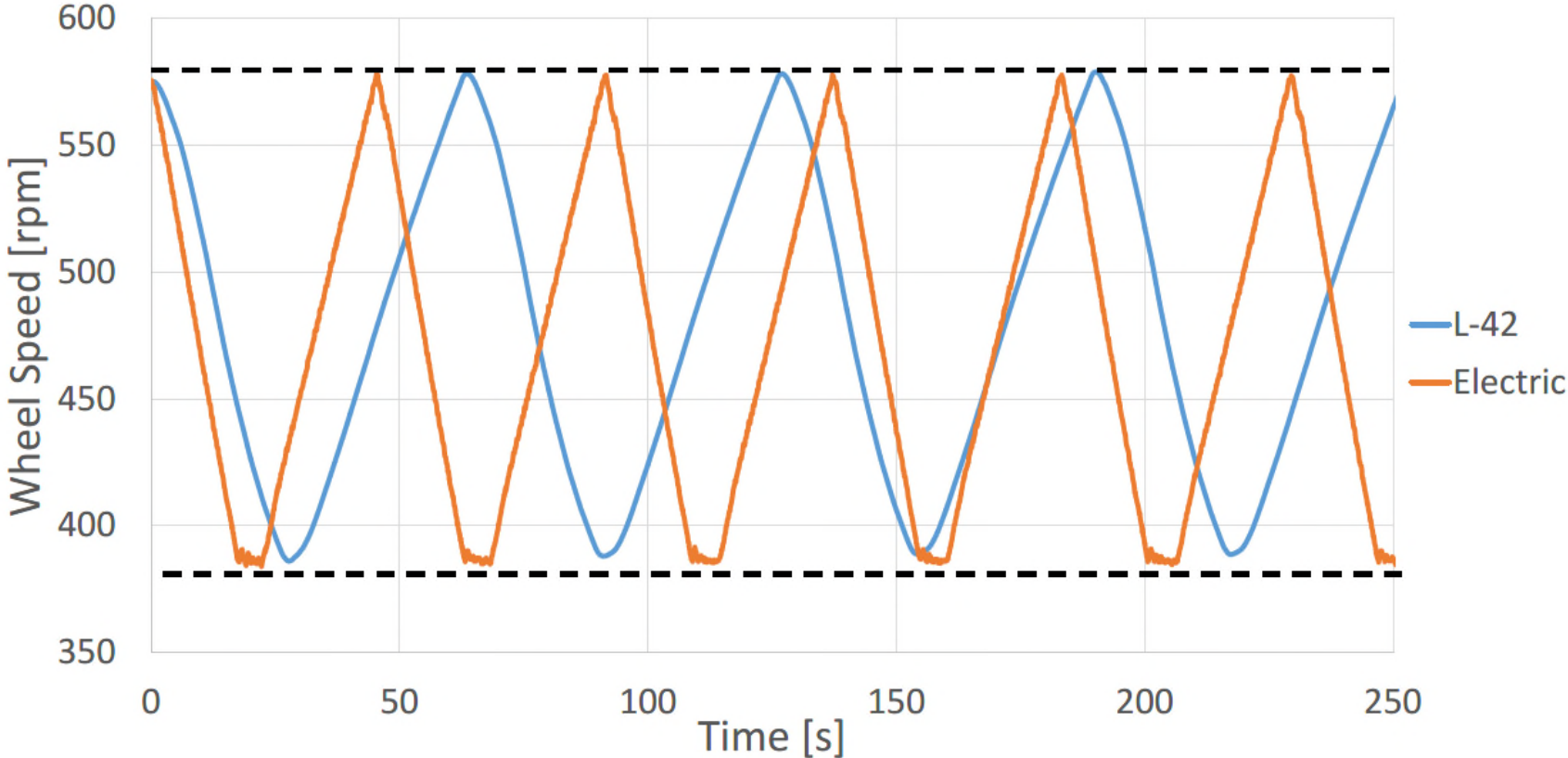

# Conditioning 4, Pinion Torque

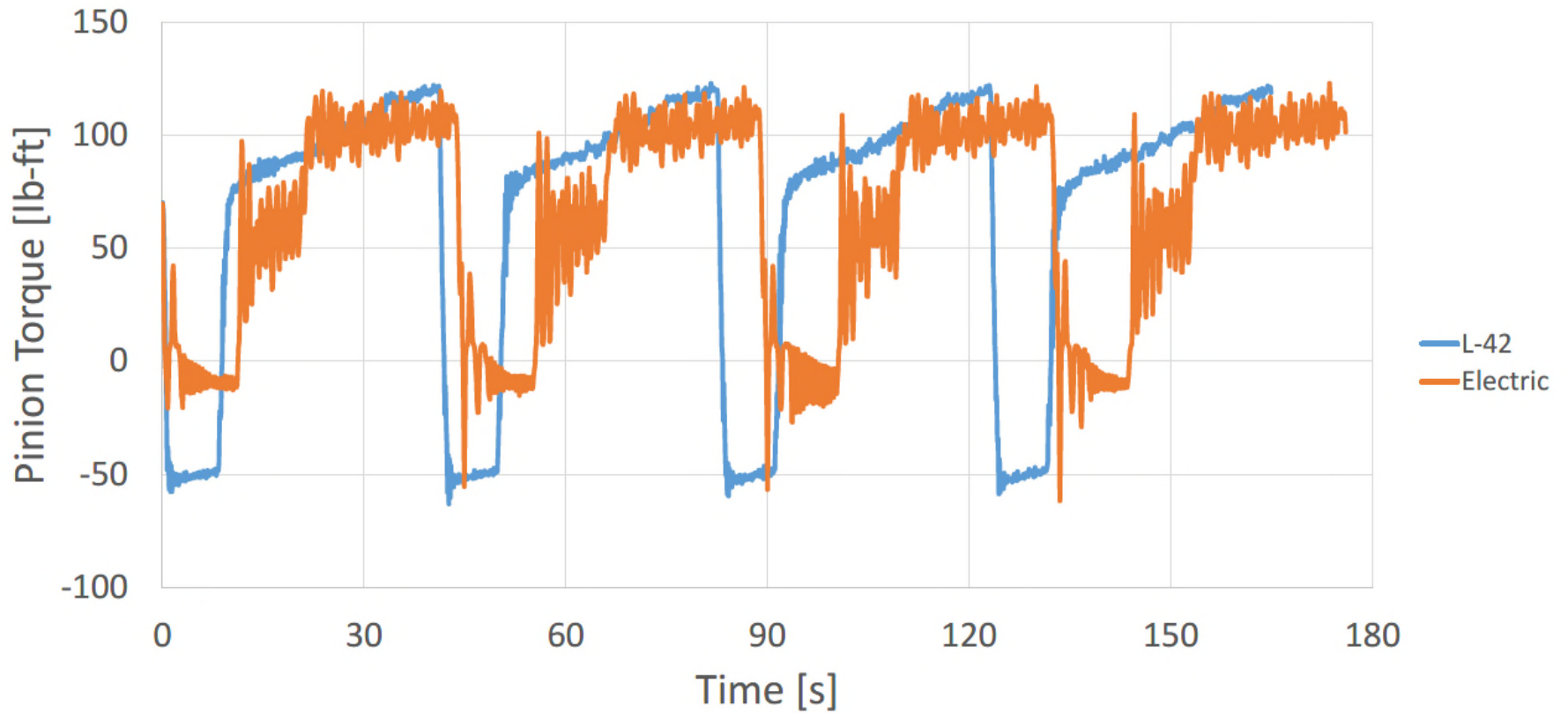



# Conditioning 4, Wheel Speed

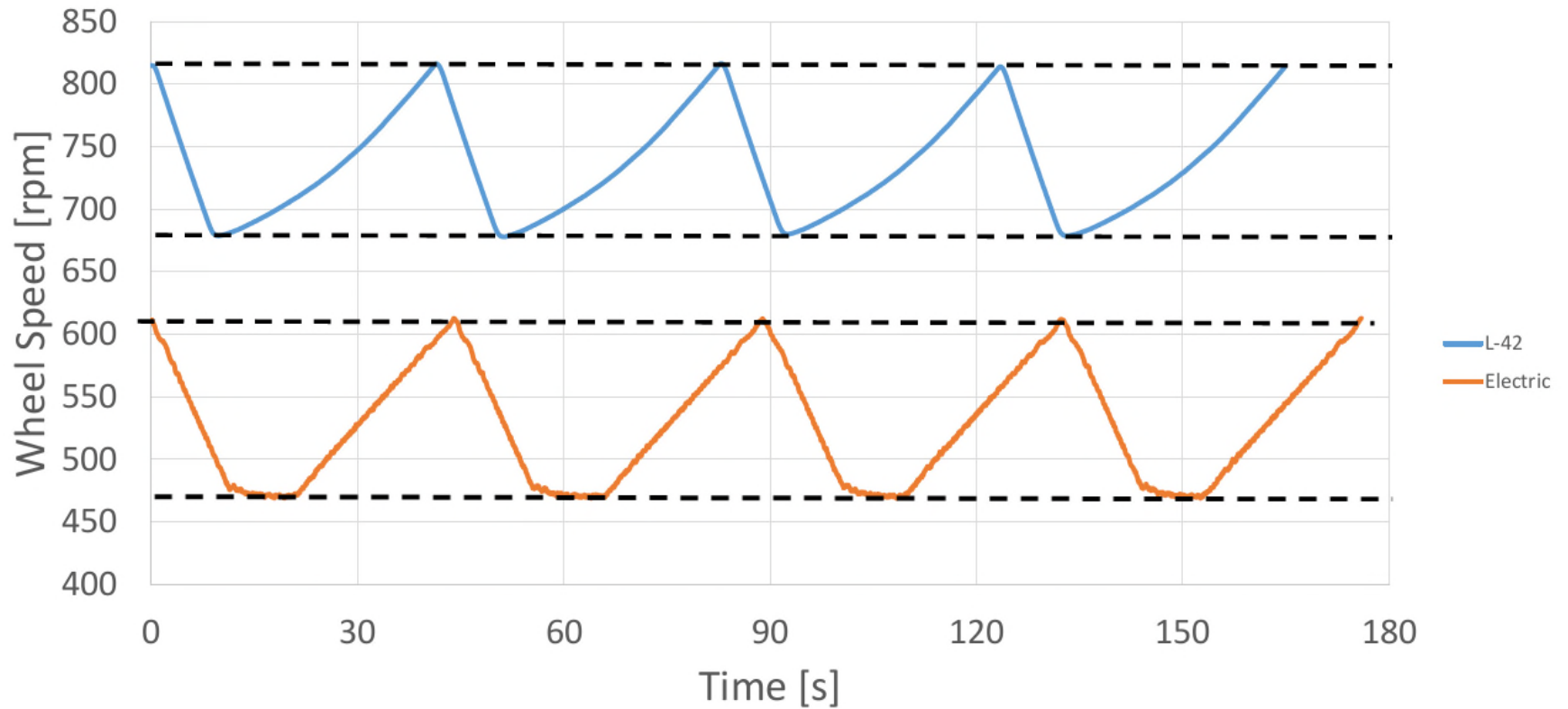

# Shock I, Pinion Torque

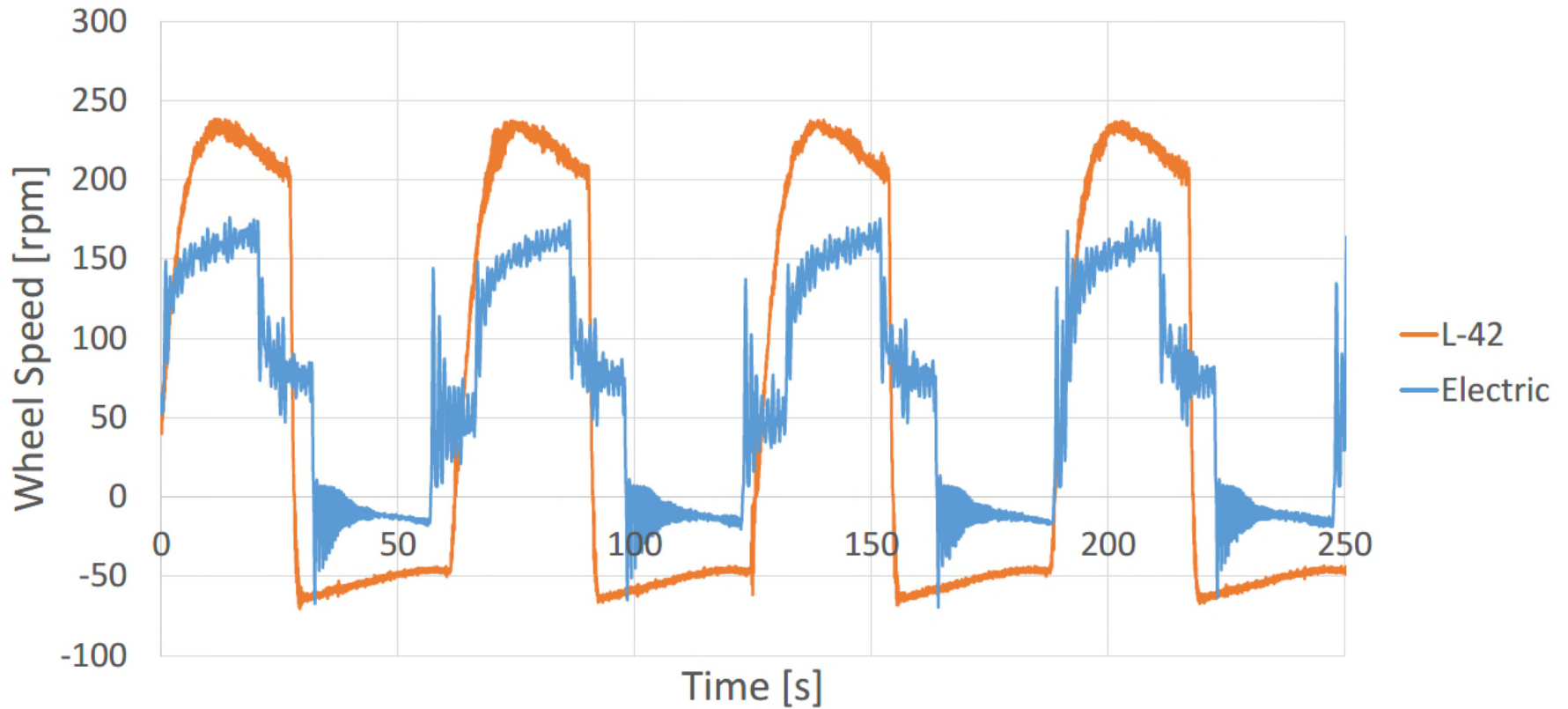

# Shock I Wheel Speed

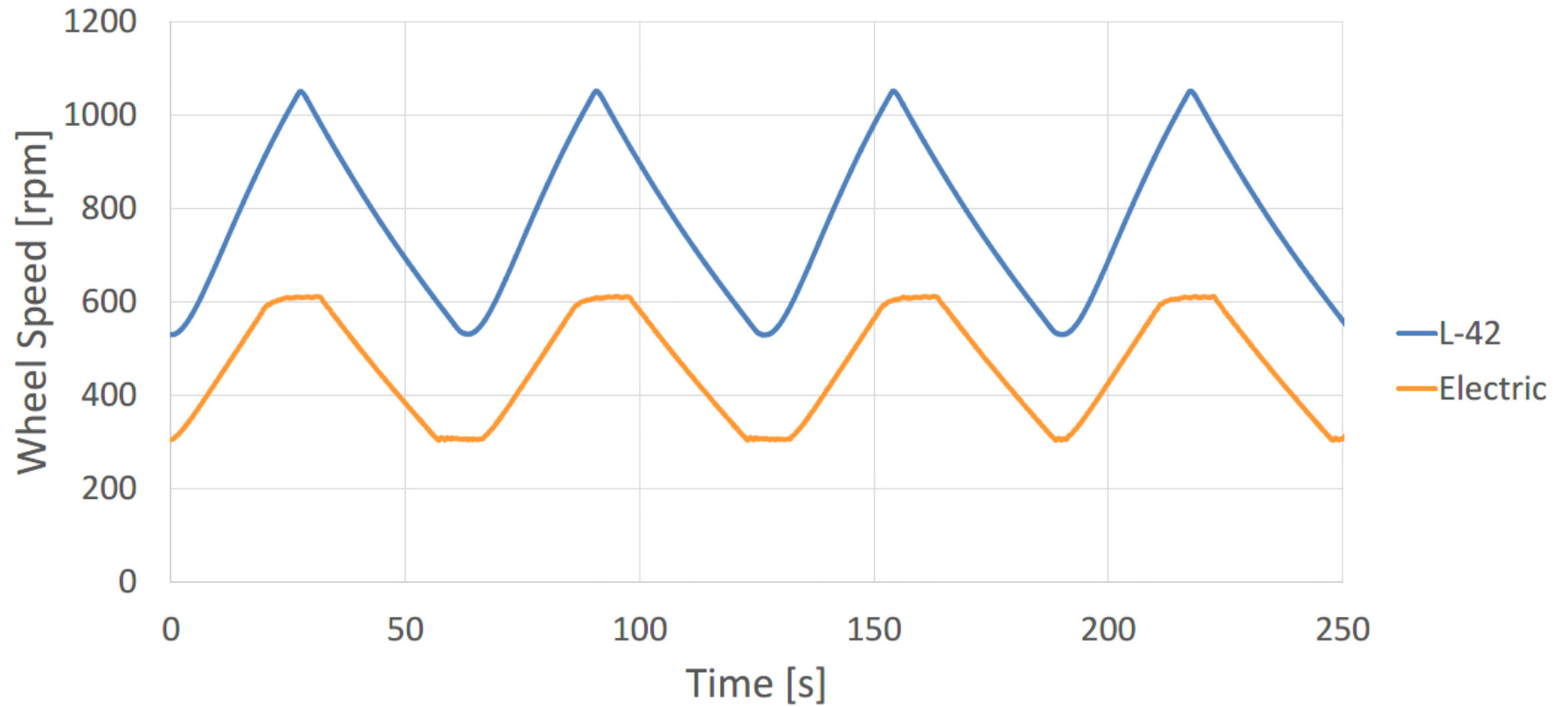



## L-42-1 Development – Hardware Donation

- ▲ **Surplus hardware available to donate to development effort**
  - ▲ Afton: Several C1L680, P8T025A
  - ▲ Intertek: 2 axles, batch unknown
  - ▲ LZ: ?
- ▲ **Quantities donated by each lab should be equal (if possible)**
- ▲ **Is SwRI ready to accept axles?**

# L-42 Proposed Report Change

 Add rater calibration expiration date to test reports

 Vote?

Test Method D7452 L-42 Form 4 Measurement Summary										
Lab:		Stand No.:			Stand Run No.:					
Oil Code:										
Axle Codes										
Assembly Date		Match No.		Serial Number		Pinion Batch		Ring Batch		
Contact Pattern Measurements										
		Drive Side				Coast -Side				
<b>Length Rating</b>	As Received									
	As Tested									
<b>Flank Rating</b>	As Received									
	As Tested									
		Contact Pattern Rater Initials								
Test Axle Build Data										
Backlash (in.)	Mfg. Specification	Mfg. Measurement	Laboratory's Position Measurements							
			1	2	3	4	Min	Max	Avg.	
Initial	.004 -.012 in.									
Final										
Increase										
<b>Initial Pinion Torque (lbf -in)</b>			Break Turn							
Inspection	Ring% Scoring				Pinion % Scoring					
	Drive Side		Coast Side		Drive Side		Coast Side			
Inspection 1										
Inspection 2										
EOT										
<b>EOT Rating Date</b>			<b>EOT Rater Initials</b>			<b>Rater Calexp</b>				



# L-42 2020 Hardware Order Update

## Significant delays in delivery

- ▲ Forging plant fire
- ▲ Raw steel supply issues

## Pilot batch delayed further, now until Mid-June, 2021

- ▲ Dana plant in Lugoff, SC scheduled to receive ring and pinions June 7
- ▲ Expect to receive assembled pilot axles by June 14



## OH – Lugoff

### ASTM Axle – Proposed change

Gabriel Waxemberg

Plant Quality Manager

*People Finding A Better Way®*

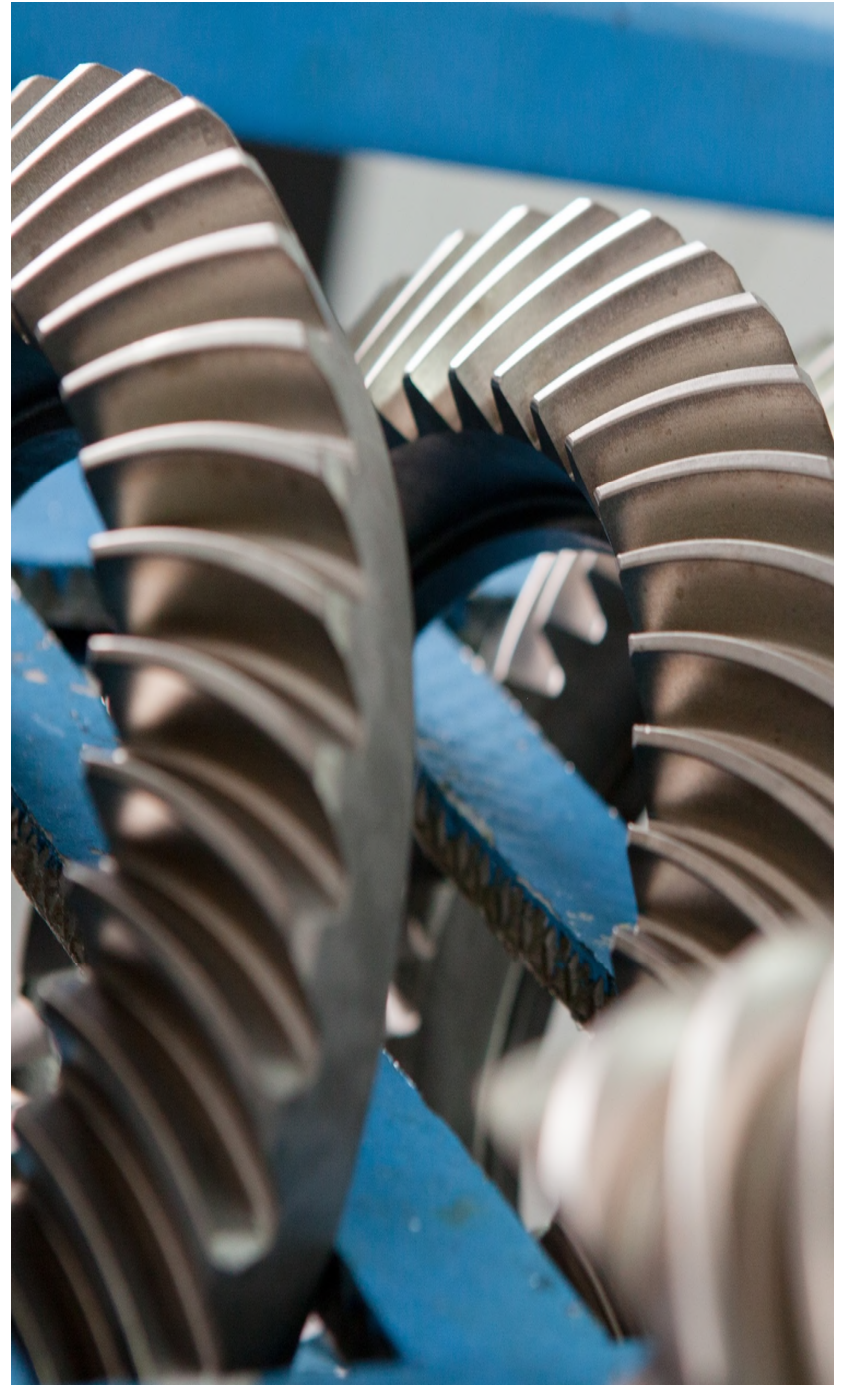

# ASTM Axle - Proposed change for this production lot

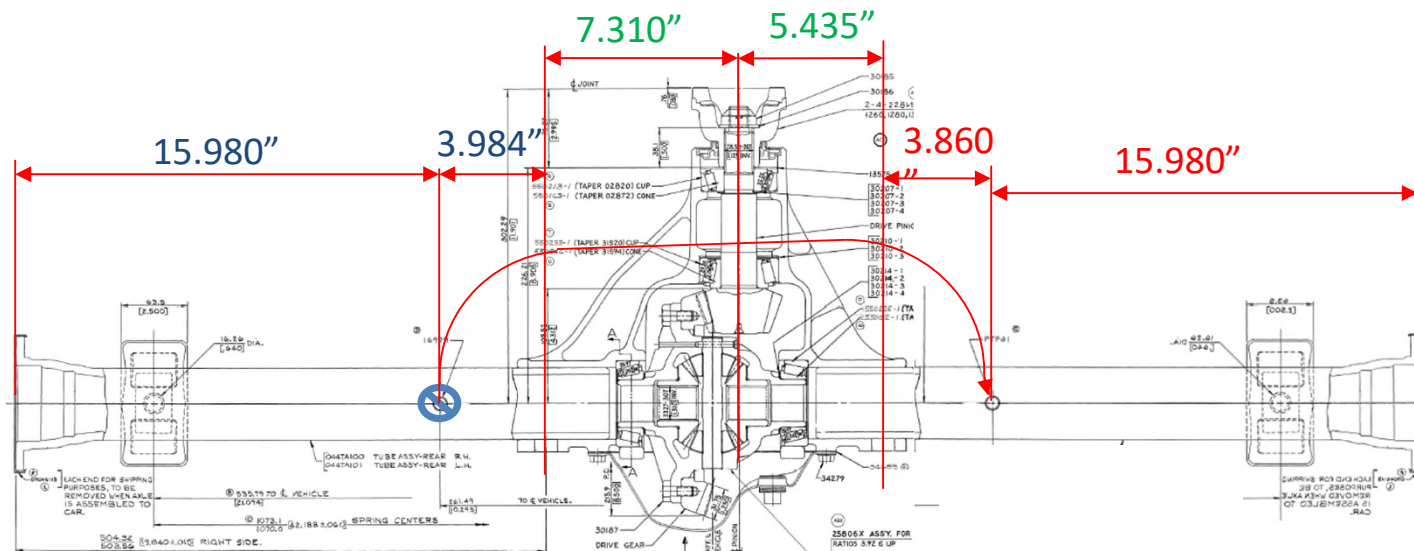

Vent removed  
Left side

Vent added  
Right side

Vote?

# L-42 Hardware Print Review

## Print from Dana of Axle Assembly, PN 044AA100

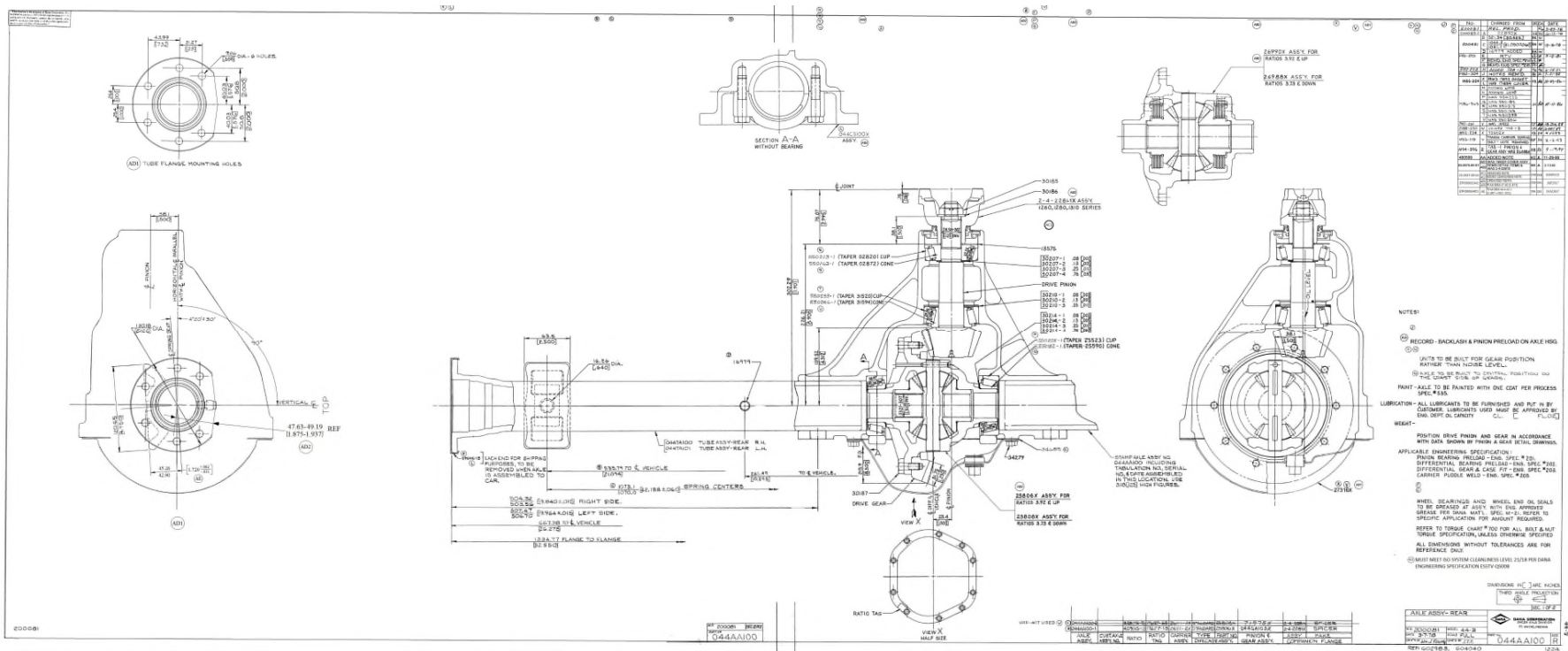

Asked Dana for ring and pinion detail drawings

Waiting for reply



Passion for Solutions™



# L-42 Hardware Print Review

## Assembly requirements

Work Instruction WIENG00001 / 1

OFTD - Lugoff, SC, US - Lugoff Offhighway

### ASTM Assembly Requirements



Dana Holding Corporation  
 1255 Commerce Drive  
 Lugoff, SC  
 29078-9164  
 (269) 567-1160

Document Identity			
Document Status and Ownership			
Current Status	<b>Approved - Released</b>		
Approval Date	August 18, 2014	Release Date	August 18, 2014
Version Author / Version Manager	Ottley, Derek		
Document Categorization			
Responsible Department	Manufacturing Engineering		
Process Name	Production / Manufacturing		
Standard Elements	ISO 9001/TS16949 Standard Elements 7 Product realization 7.1 Planning of product realization 7.5 Production and service provision		
Dana Departments	Manufacturing Engineering		
Dana Areas			

THIS DOCUMENT CONTAINS CONFIDENTIAL INFORMATION. Its use is restricted to employees with a need to know and third parties with a need to know and who have signed a non-disclosure agreement. Uncontrolled when printed. Please refer to the electronic edition maintained in CompliantPro to ensure the most recent revision level.

Release and Audit Schedule	
Release Schedule	When Approved <input type="checkbox"/> <b>Allow Administrator to Release Document Early</b>
Expiration Schedule	When Superseded or Obsoleted
Audit Schedule	12 Month(s)
Special Handling on Release	
<input checked="" type="checkbox"/> Update Completed Trainee Records	

- 1.0 Purpose/ Propósito/ Objetivo/ 目的/ วัตถุประสงค์/ Zweck/ Objectif/ Scopo**

The purpose of this document is to instruct operators of the special assembly requirements for ASTM lab order axles.
- 2.0 Scope/ Alcance/ Escopo/ 範圍/ ขอบเขต/ Geltungsbereich/ Étendue/ Ambito**

The scope of this document covers the ASTM L33 (Dana 30 Model), ASTM L42 (Dana 44Model) and ASTM L37 (Dana 60Model) axles, and serves to outline customer specified requirements that differ from existing assembly procedures.
- 3.0 Responsibilities/ Responsabilidades/ 职责/ ความรับผิดชอบ/ Verantwortung/ Responsabilités/ Responsabilità**

# New Issues



Thanks!



*Passion for Solutions™*



**L-42 Surveillance Panel Membership/Attendance  
Virtual Meeting, Microsoft Teams  
May 12, 2021**

Present = P Accept = A Tent. = T Decline = D	Name	Voting Non-Voting	Company Name Company Address	Contact information	
	Aguirre, Nancy	NV	Intertek Automotive Research	Phone:	
			5404 Bandera Rd. San Antonio, TX 78238	E-mail:	<a href="mailto:nancy.aguirre@intertek.com">nancy.aguirre@intertek.com</a>
P	Banas, Rob	V	ExxonMobil Fuels, Lubricants & Specialties	Phone:	678-493-3930
			114 Arcadia Park Dr. Canton, GA 30114	E-mail:	<a href="mailto:rob.a.banas@exxonmobil.com">rob.a.banas@exxonmobil.com</a>
	Barrera, Tony	NV	Intertek Automotive Research	Phone:	210-523-4653
			5404 Bandera Rd. San Antonio, TX 78238	E-mail:	<a href="mailto:tony.barrera@intertek.com">tony.barrera@intertek.com</a>
P	Bealko, Steven	NV	The Lubrizol Corporation	Phone:	
				E-mail:	
P	Beck, Dylan	V	ASTM Test Monitoring Center	Phone:	724-355-1854
			6555 Penn Ave Pittsburg, PA 15206	E-mail:	<a href="mailto:djb@astmtmc.cmu.edu">djb@astmtmc.cmu.edu</a>

**L-42 Surveillance Panel Membership/Attendance  
Virtual Meeting, Microsoft Teams  
May 12, 2021**

Present = P Accept = A Tent. = T Decline = D	Name	Voting Non-Voting	Company Name Company Address	Contact information	
P	Bell, Don	NV	Afton Chemical	Phone:	804-788-6332
			500 Spring St. Richmond, VA 23219	E-mail:	<a href="mailto:don.bell@aftonchemical.com">don.bell@aftonchemical.com</a>
	Cabaj, Mike	V	Linamar	Phone:	313-820-0119
			32233 W. 8 Mile Road Livonia, MI 48152	E-mail:	<a href="mailto:michael.cabaj@linamar.com">michael.cabaj@linamar.com</a>
	Camposo, Lucas	NV	Evonik	Phone:	215-706-5809
			723 Electronic Dr Horsham, PA 19044	E-mail:	<a href="mailto:lucas.camposo@evonik.com">lucas.camposo@evonik.com</a>
P	Carter, Jason	V	Meritor	Phone:	
				E-mail:	<a href="mailto:Jason.Carter@meritor.com">Jason.Carter@meritor.com</a>
	Clark, Jeff	NV	ASTM Test Monitoring Center	Phone:	412-365-1032
			6555 Penn Ave Pittsburg, PA 15206	E-mail:	<a href="mailto:jac@astmtmc.cmu.edu">jac@astmtmc.cmu.edu</a>

**L-42 Surveillance Panel Membership/Attendance  
Virtual Meeting, Microsoft Teams  
May 12, 2021**

Present = P Accept = A Tent. = T Decline = D	Name	Voting Non-Voting	Company Name Company Address	Contact information	
	Cereghino, Brian	NV	IPAC Inc.	Phone:	
			E-mail:	<a href="mailto:bcereghino@ipac-inc.com">bcereghino@ipac-inc.com</a>	
P	Comfort, Allen	V	US Army CCDC	Phone:	586-282-4225
			E-mail:	<a href="mailto:allen.s.comfort.civ@mail.mil">allen.s.comfort.civ@mail.mil</a>	
P	Drlja, Kristijan	NV	The Lubrizol Corporation	Phone:	440-391-6374
			29400 Lakeland Boulevard Wickliffe, OH 44092	E-mail:	<a href="mailto:krdr@lubrizol.com">krdr@lubrizol.com</a>
	Farber, Frank	NV	TMC	Phone:	412-365-1030
			6555 Penn Ave Pittsburg, PA 15206	E-mail:	<a href="mailto:fmf@astmtmc.cmu.edu">fmf@astmtmc.cmu.edu</a>
	Foecking, Brian	NV	The Lubrizol Corporation	Phone:	440-347-2130
			29400 Lakeland Boulevard Wickliffe, OH 44092	E-mail:	<a href="mailto:bjf@lubrizol.com">bjf@lubrizol.com</a>

**L-42 Surveillance Panel Membership/Attendance  
Virtual Meeting, Microsoft Teams  
May 12, 2021**

Present = P Accept = A Tent. = T Decline = D	Name	Voting Non-Voting	Company Name Company Address	Contact information	
P	Friesen, Terry	NV	IPAC Inc.	Phone:	925-556-5530
			7600 Dublin Blvd, Suite 240 Dublin, CA 94568	E-mail:	<a href="mailto:tfriesen@ipac-inc.com">tfriesen@ipac-inc.com</a>
P	Goyal, Arjun	V	BASF	Phone:	914-785-2083
			500 White Plains Rd Tarrytown, NY 10591	E-mail:	<a href="mailto:arjun.goyal@basf.com">arjun.goyal@basf.com</a>
	Henderson, Jeff	NV	Afton Chemical	Phone:	804-788-5800 X 8412
			500 Spring St. Richmond, VA 23219	E-mail:	<a href="mailto:jeff.henderson@aftonchemical.com">jeff.henderson@aftonchemical.com</a>
	Horvath, Dan	NV	Afton Chemical	Phone:	248-514-2551
			2000 Town Center, Suite 1160 Southfield, MI 48075	E-mail:	<a href="mailto:dan.horvath@aftonchemical.com">dan.horvath@aftonchemical.com</a>
	Jackson, Matt	NV	Southwest Research Institute	Phone:	210-522-6981
				E-mail:	<a href="mailto:matt.jackson@swri.org">matt.jackson@swri.org</a>

**L-42 Surveillance Panel Membership/Attendance  
Virtual Meeting, Microsoft Teams  
May 12, 2021**

Present = P Accept = A Tent. = T Decline = D	Name	Voting Non-Voting	Company Name Company Address	Contact information	
	Joy, Tisha	NV	BASF	Phone:	914-785-2206
			E-mail:	<a href="mailto:tisha.joy@basf.com">tisha.joy@basf.com</a>	
P	Kanga, Percy	NV	ExxonMobil Research & Engineering	Phone:	908-335-3780
			1545 Rte. 22 East Clinton, NJ 08801	E-mail:	<a href="mailto:percy.r.kanga@exxonmobil.com">percy.r.kanga@exxonmobil.com</a>
D	Koehler, Brian	NV	Southwest Research Institute	Phone:	210-522-3588
			P.O. Drawer 28510 San Antonio, TX 78228-0510	E-mail:	<a href="mailto:Bkoehler@swri.org">Bkoehler@swri.org</a>
	Kuchta, Tyler	NV	The Lubrizol Corporation	Phone:	440-347-5868
			29400 Lakeland Boulevard Wickliffe, OH 44092	E-mail:	<a href="mailto:tyler.kuchta@lubrizol.com">tyler.kuchta@lubrizol.com</a>
P	LaBond, Jessica	NV	Meritor	Phone:	248-872-3055
			2135 W. Maple Rd Troy, MI 48084	E-mail:	<a href="mailto:Jessica.LaBond@meritor.com">Jessica.LaBond@meritor.com</a>

**L-42 Surveillance Panel Membership/Attendance  
Virtual Meeting, Microsoft Teams  
May 12, 2021**

Present = P Accept = A Tent. = T Decline = D	Name	Voting Non-Voting	Company Name Company Address	Contact information	
P	Lange, Anthony	V	Intertek Automotive Research	Phone:	210-634-1103
			5404 Bandera Rd. San Antonio, TX 78238	E-mail:	<a href="mailto:anthony.lange@intertek.com">anthony.lange@intertek.com</a>
T	Lonsway, Chris	NV	The Lubrizol Corporation	Phone:	440-347-4517
			29400 Lakeland Boulevard Wickliffe, OH 44092	E-mail:	<a href="mailto:chris.lonsway@lubrizol.com">chris.lonsway@lubrizol.com</a>
	Louis, Caroline	NV	Southwest Research Institute	Phone:	843-471-6283
			6220 Culebra Rd. Antonio, TX 78238	E-mail:	<a href="mailto:caroline.louis@swri.org">caroline.louis@swri.org</a>
	Milner, Jeff	NV	Tianhe Chemical	Phone:	804-252-6928
				E-mail:	<a href="mailto:jmilner@tianhe-us.com">jmilner@tianhe-us.com</a>
	Morris, Jeanelle	NV	Navistar	Phone:	331-332-1661
			2701 Navistar Dr Lisle, IL 60532	E-mail:	<a href="mailto:jeanelle.morris@navistar.com">jeanelle.morris@navistar.com</a>

**L-42 Surveillance Panel Membership/Attendance  
Virtual Meeting, Microsoft Teams  
May 12, 2021**

Present = P Accept = A Tent. = T Decline = D	Name	Voting Non-Voting	Company Name Company Address	Contact information	
P	Mosher, Donna	NV	BASF	Phone:	269-217-1715
			100 Park Ave Florham Park, NJ 07932	E-mail:	<a href="mailto:donna.mosher@basf.com">donna.mosher@basf.com</a>
P	Muransky, Troy	V	AAM	Phone:	734-564-8406
			1840 Holbrook Detroit, MI	E-mail:	<a href="mailto:troy.muransky@aam.com">troy.muransky@aam.com</a>
	Rabinowitz, Daniel	NV	Chrysan	Phone:	
				E-mail:	
P	Sangpeal, Matt	V/Chair	Afton Chemical	Phone:	804-788-5364
			500 Spring St. Richmond, VA 23219	E-mail:	<a href="mailto:matt.sangpeal@aftonchemical.com">matt.sangpeal@aftonchemical.com</a>
	Sattler, Eric	NV	CCDC-GVSC	Phone:	586-282-2272
			Warren, MI	E-mail:	<a href="mailto:eric.r.sattler.civ@mail.mil">eric.r.sattler.civ@mail.mil</a>

**L-42 Surveillance Panel Membership/Attendance  
Virtual Meeting, Microsoft Teams  
May 12, 2021**

Present = P Accept = A Tent. = T Decline = D	Name	Voting Non-Voting	Company Name Company Address	Contact information	
P	Schwenk, Daniel	NV	Afton Chemical	Phone:	804-788-6326
			500 Spring St. Richmond, VA 23219	E-mail:	<a href="mailto:daniel.schwenk@aftonchemical.com">daniel.schwenk@aftonchemical.com</a>
P	Slocum, Robert	V	The Lubrizol Corporation	Phone:	440-347-5102
			29400 Lakeland Boulevard Wickliffe, OH 44092	E-mail:	<a href="mailto:robert.slocum@lubrizol.com">robert.slocum@lubrizol.com</a>
P	Smith, Dale	NV	Intertek Automotive Research	Phone:	412-855-6854
			5404 Bandera Rd. San Antonio, TX 78238	E-mail:	<a href="mailto:dale.smith@intertek.com">dale.smith@intertek.com</a>
	Thrash, Steven	NV	US Army CCDC	Phone:	586-282-5170
			6501 E. 11 Mile Rd. Warren, MI 48397	E-mail:	<a href="mailto:steven.j.thrash.civ@mail.mil">steven.j.thrash.civ@mail.mil</a>
	Uy, Dairene	NV	Shell	Phone:	
				E-mail:	



**L-42 Surveillance Panel Membership/Attendance  
Virtual Meeting, Microsoft Teams  
May 12, 2021**

Present = P Accept = A Tent. = T Decline = D	Name	Voting Non-Voting	Company Name Company Address	Contact information	
P	Venhoff, Wes	NV	The Lubrizol Corporation	Phone:	440-347-4879
			29400 Lakeland Boulevard Wickliffe, OH 44092	E-mail:	<a href="mailto:wes.venhoff@lubrizol.com">wes.venhoff@lubrizol.com</a>
P	Warden, Rebecca	V	Southwest Research Institute	Phone:	210-522-6266
				E-mail:	<a href="mailto:rebecca.warden@swri.org">rebecca.warden@swri.org</a>
A	Zreik, Khaled	NV	General Motors	Phone:	248-977-9214
			823 Joslyn Ave Pontiac, MI 48340-2925	E-mail:	<a href="mailto:khaled.zreik@gm.com">khaled.zreik@gm.com</a>
P	Zyski, Amy	V	Dana Incorporated	Phone:	419-887-3432
			3939 Technology Dr Maumee, OH 43537	E-mail:	<a href="mailto:amy.zyski@dana.com">amy.zyski@dana.com</a>
				Phone:	
				E-mail:	

**L-42 Surveillance Panel Membership/Attendance  
Virtual Meeting, Microsoft Teams  
May 12, 2021**

Present = P Accept = A Tent. = T Decline = D	Name	Voting Non-Voting	Company Name Company Address	Contact information	
				Phone:	
				E-mail:	
				Phone:	
				E-mail:	
				Phone:	
				E-mail:	
				Phone:	
				E-mail:	
				Phone:	
				E-mail:	

**L-42 Surveillance Panel Membership/Attendance  
Virtual Meeting, Microsoft Teams  
May 12, 2021**

<b>Present = P Accept = A Tent. = T Decline = D</b>	<b>Name</b>	<b>Voting Non-Voting</b>	<b>Company Name Company Address</b>	<b>Contact information</b>	
				Phone:	
				E-mail:	