

Date:

To: Subcommittee D02.B0 members
Technical Contact: Lyle Bowman, bowlman@ramwobl.com, 415- 479 -3004
Work Item: WK49675
Ballot Action: New engine oil test method
Rationale: This test method is expected be in a new engine oil specification

**Standard Test Method for
 Determination of Timing Chain Wear in a Turbocharged, Direct Injection,
 Spark Ignition, Four-Cylinder Engine¹**

This standard is issued under the fixed designation X XXXX; the number immediately following the designation indicates the year of original adoption or, in the case of revision, the year of last revision. A number in parentheses indicates the year of last reapproval. A superscript epsilon (ϵ) indicates an editorial change since the last revision or reapproval.

INTRODUCTION

Portions of this test method are written for use by laboratories that make use of ASTM Test Monitoring Center (TMC)² services (see Annex A1-A4).

The TMC provides reference oils, and engineering and statistical services to laboratories that desire to produce test results that are statistically similar to those produced by laboratories previously calibrated by the TMC.

In general, the Test Purchaser decides if a calibrated test stand is to be used. Organizations such as the American Chemistry Council require that a laboratory utilize the TMC services as part of their test registration process. In addition, the American Petroleum Institute and the Gear Lubricant Review Committee of the Lubricant Review Institute (SAE International) require that a laboratory use the TMC services in seeking qualification of oils against their specifications.

The advantage of using the TMC services to calibrate test stands is that the test laboratory (and hence the Test Purchaser) has an assurance that the test stand was operating at the proper level of test severity. It should also be borne in mind that results obtained in a non-calibrated test stand may not be the same as those obtained in a test stand participating in the ASTM TMC services process.

Laboratories that choose not to use the TMC services may simply disregard these portions.

1. Scope

1.1 Undesirable timing chain wear has been observed with gasoline turbocharged direct injection (GTDI) engines in field service, and data from correlating laboratory engine tests have shown **that chain wear can be affected by** appropriately formulated engine lubricating oil ~~minimizes that wear~~. **A refined version of the correlative** laboratory engine test has been developed to provide a means for screening lubricating oils for that specific purpose. The laboratory engine test is 216 h in length, conducted under varying conditions, and the increase in timing chain length determined at the end of test is the primary result. **This test method is commonly known as the Sequence X, Chain Wear Test.**

1.2 The values stated in SI units are to be regarded as the standard. (Values in parentheses are provided for information.)

¹ This test method is under the jurisdiction of ASTM Committee D02 on Petroleum Products, Liquid Fuels, and Lubricants and is the direct responsibility of Subcommittee D02.B0.01 on Passenger Car Engine Oils.

² ASTM Test Monitoring Center (TMC), 6555 Penn Ave., Pittsburgh, PA 15206-4489.

1.2.1 *Exception*—Where there is no direct SI equivalent such as screw threads, national pipe threads/diameters, tubing size, or specified single source equipment.

1.3 *This standard does not purport to address all of the safety concerns, if any, associated with its use. It is the responsibility of the user of this standard to establish appropriate safety and health practices and determine the applicability of regulatory limitations prior to use.* See Annex A6 for general safety precautions.

1.4 Table of Contents:	Section
Scope	1
Referenced Documents	2
Terminology	3
Summary of Test Method	4
Significance and Use	5
Apparatus	6
Test Engine	6.1
Reagents	7
Preparation of Apparatus	8
Chain and Camshaft Installation	8.20.6
Timing Chain Measurement	8.21.5
Electronic Throttle controller	8.18
Measurement Instrumentation	8.24
Test Procedure	9
Break-in Procedure	9.1.1
Engine Operation Procedure	9.2
Cycling Schedule	9.2.4
Stages and Ramps	9.2.4.3
Oil Level Check and Sampling	9.4.1
Blowby Flow Rate Adjustment	9.7
Diagnostic Data review	10
Test Results	11
Primary Result – Timing Chain Elongation	11.1.1
Report	12
Precision and Bias	13
Test Precision	13.1
Keywords	14
ANNEXES	
ASTM TMC - Organization	A1
ASTM TMC - Calibration Procedures	A2
ASTM TMC – Maintenance Activities	A3
ASTM TMC – Related Information	A4
Engine Parts	A5
Assembled Test Engine	A5.1
Safety Precautions	A6
Engine Rebuild Templates	A7
Cylinder Head Measurements	A8.1
Cylinder Bore Measurements	A8.2
Bearing Journal Measurements	A8.3
Various Engine Part Photographs and Figures	A9
Typical Ramps (temperature, torque, blowby)	A9.23
Control and Data Acquisition Requirements	A10

APPENDIXES

Sources of Materials and Information
Engine Brackets - Schematics

X1.
X2.

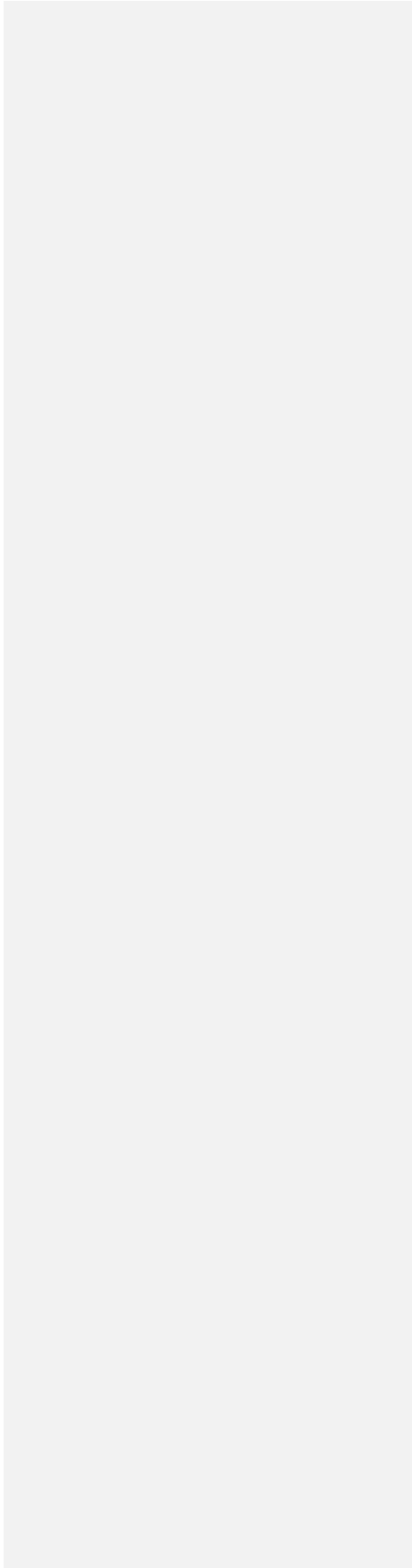

2. Referenced Documents

2.1 ASTM Standards³:

D445 Test Method for Kinematic Viscosity of Transparent and Opaque Liquids (and Calculation of Dynamic Viscosity)
 D664 Test Method for Acid Number of Petroleum Products by Potentiometric Titration
 D4739 Test Method for Base Number Determination by Potentiometric Hydrochloric Acid Titration
 D5059 Test Methods for Lead in Gasoline by X-Ray Spectroscopy
 D5185 Test Method for Multielement Determination of Used and Unused Lubricating Oils and Base Oils by Inductively Coupled Plasma Atomic Emission Spectrometry (ICP-AES)
 D5862 Test Method for Evaluation of Engine Oils in Two-Stroke Cycle Turbo-Supercharged 6V92TA Diesel Engine (Withdrawn 2009);
 D5967 TGA
 D6304 Test Method for Determination of Water in Petroleum Products, Lubricating Oils, and Additives by Coulometric

Comment [JS1]: Add TGA description

ANSI MC96.1 Temperature Measurement-Thermocouples

2.3 ~~Ford 2.0L-4V TiVCT GTDi Build Manual 2012 MY ILCB5E 543-AA~~ 2012 Ford Explorer 2.0L-4V TiVCT GTDi Build Manual

3. Terminology

3.1 Definitions:

3.1.1 *blowby, n*—in internal combustion engines, the combustion products and unburned air-and-fuel mixture that enter the crankcase. D4175

3.1.2 *engine oil, n*—a liquid that reduces friction or wear, or both, between the moving parts within an engine; removes heat, particularly from the underside of pistons; and serves as a combustion gas sealant for piston rings.

3.1.2.1 *Discussion*—It may contain additives to enhance certain properties. Inhibition of engine rusting, deposit formation, valve train wear, oil oxidation, and foaming are examples. D4175

3.1.3 *wear, n*—the loss of material from a surface, generally occurring between two surfaces in relative motion, and resulting from mechanical or chemical action or a combination of both. D4175

3.1.4 *out of specification data, n*—in data acquisition, sampled value of a monitored test parameter that has deviated beyond the procedural limits.

3.1.5 *reading, n*—in data acquisition, the reduction of data points that represent the operating conditions observed in the time period as defined in the test procedure

3.1.6 *filtering, n*—in data acquisition, a means of attenuating signals in a given frequency range. They can be mechanical (volume tank, spring, mass) or electrical (capacitance, inductance) or digital (mathematical formulas), or

³ For referenced ASTM standards, visit the ASTM website, www.astm.org, or contact ASTM Customer Service at service@astm.org. For *Annual Book of ASTM Standards* volume information, refer to the standard's Document Summary page on the ASTM website.

⁴ The engine is based on the Ford Motor Co. 2012 Explorer engine, and a completely assembled new test engine is available from Ford Component Sales, Ford Motor Co., 290 Town Center Dr., Dearborn, MI 48126.

a combination thereof. Typically, a low-pass filter attenuates the unwanted high frequency noise.

3.1.7. *time constant, n*—in data acquisition, A value which represents a measure of the time response of a system. For a first order system responding to a step change input, it is the time required for the output to reach 63.2 % of its final value.

3.2 *Definitions of terms Specific to This Standard:*

3.2.1 *timing chain, n*—the part of an internal combustion engine that synchronizes the rotation of the crankshaft and the camshaft(s) so that the engine's valves open and close at the proper times during each cylinder's intake and exhaust strokes; in this engine, the timing chain is a ~~roller chain~~ an inverted tooth configuration.

3.2.2 *wear, n*—the loss of material from a surface, generally occurring between two surfaces in relative motion, and resulting from mechanical or chemical action or a combination of both. D4175

3.2.3 *PCM, n*—an engine control unit, most commonly called the powertrain control module (PCM), is an electronic device that instantaneously controls a series of actuators on an internal combustion engine to ensure optimal engine performance.

3.2.4 *enrichment, n*—in internal combustion engine operation, a fuel consumption rate in excess of that which would achieve a stoichiometric air-to-fuel ratio.

3.2.4.1 *Discussion*—Enrichment is usually indicated by elevated CO levels and can also be detected with an extended range air/fuel ratio sensor.

3.2.5 *Lambda, n*—the ratio of actual air mass induced, during engine operation, divided by the theoretical air mass requirement at the stoichiometric air-fuel ratio for the given fuel.

3.2.5.1 *Discussion*—A Lambda value of 1.0 denotes a stoichiometric air-fuel ratio.

3.2.6 *low-temperature, light-duty conditions, n*—indicative of engine oil and coolant temperatures that average below normal warmed-up temperatures, and engine speeds and power outputs that average below those encountered in typical highway driving.

3.2.7 *ramping, n*—the prescribed rate of change of a variable when one set of operating conditions is changed to another set of operating conditions.

4. Summary of CW (Chain Wear) Test Method

4.1 The test engine is completely rebuilt before each test and essentially all aspects of assembly are specified in detail. The piston ring gaps are increased to increase the level of blowby and crankcase ventilation is modified to exacerbate chain wear.

4.2 The timing chain length is measured before and after engine break in, and at the end of test (216 h). The test is conducted for 54 cycles, each 4 h cycle consisting of operation at two stages with differing operating conditions for a total test length of 216 h. While the operating conditions are varied within each cycle, overall they can be characterized as a mixture of low-temperature and moderate-temperature, light and medium duty operating conditions.

4.3 ~~The timing chain length is measured before and after engine break in, and at the end of test (216 h).~~ The increase in timing chain length, determined at the end of test, is the primary test result.

5. Significance and Use

5.1 This test method evaluates an automotive engine oil's lubricating efficiency in inhibiting timing chain lengthening under operating conditions selected to accelerate timing chain wear ~~deformation~~. Varying quality reference oils of known wear performance were used in developing the operating conditions of the test procedure.

5.2 The test method can be used to screen lubricants for satisfactory lubrication of an engine timing chain, and has application in gasoline automotive engine oil specifications such as the following:

5.2.1 ILSAC GF-6.

5.2.2 Specification D4485

~~5.2.4 Military Specification MIL-PRF-2104.~~

5.2.5 SAE Classification J183.

6. Apparatus – General Description

6.1 Timing Chain Test Engine

(1) The test engine is a Ford 2.0 L, spark ignition, four stroke, four-cylinder, GTDI engine^{4,7}, with dual overhead camshafts driven by a timing chain, four valves per cylinder and electronic fuel injection.

- (2) Assembled test engine part number and description (Table A5.1).
- (3) Configure a test stand to accept the test engine. (Suggested arrangement (X2.1))

6.2 Reusable Engine Parts and Fasteners

- (1) All other engine parts, other than the 'Required New Engine Parts' (Paragraph 6.3), can be used for six maximum tests as long as they remain serviceable (see Tables A5.2 and A5.3).
- (2) Crankshaft and bearings, connecting rods and bearings, pistons, camshafts, timing chain covers, cylinder blocks, cylinder head assemblies, turbocharger, PCV valve and fuel injectors may be used for a maximum of 6 tests as long as they remain serviceable. These parts should be kept together as a set for all 6 tests.
- (3) The PCV valve is flow tested before each test to ensure it meets the required flow. The PCV stays with the test stand as long as it remains within serviceable test limits (see section 8.6).
- (4) Damaged threads in the block can be corrected with commercially available thread inserts.

6.3 Required New Engine Parts for each test (the "Test Parts")

- (1) The Test Parts and Gaskets Lists (Tables A5.4 and A5.5) describe these parts.
- (2) Use new valve train drive parts and piston rings for each test.
- (3) Do not modify or alter test parts without the approval of the Sequence X Test Surveillance Panel.

6.4 Additional Related Parts and Tools

- (1) The Test Stand Setup Parts and Special Parts Lists (Tables A5.6 and A5.7, respectively), with a few noted exceptions, can be reused for numerous tests as long as they remain serviceable.
- (2) Engine parts other than valve train and drive parts can be replaced during the test, provided the reason for replacement was not oil related and does not affect the oil.

6.5 Special service tools

- (1) A complete list of special tools for the test engine is shown in (Table A5.8)
- (2) The tools are available from a Ford dealership.
- (3) These are designed to aid in performing several service items, in addition to the following specific service items that require special tools to perform the functions indicated (if not self-explanatory).

6.6 Specially Fabricated Engine Parts

- (1) The following subsections detail the specially fabricated engine parts required in this test method:
- (2) Intake Air System can be fabricated but must use the stock 2012 Explorer air cleaner assembly (Table A5.6, X1.2) and MAF. (Paragraph 8.22.13)
- (3) Use a modified oil pan with dipstick, fill port and pick up tube listed in (Table A5.7, X1.28, Figure 6)

Note 1 – Sources for some materials and information provided in Appendix X1.

6.7 Other Special Equipment

- (1) Use an appropriate air conditioning system to control the temperature and pressure of the intake air to meet the requirements listed in Tables 3 and 4.
- (2) An appropriate fuel supply system is necessary.
- (3) The control and data acquisition system requirements are listed in Annex A10.
- (4) Use an appropriate exhaust system to control the pressure and monitor the temperature of the exhaust gases listed in Table 4.

6.8 Driveline

- (1) Use the flywheel, clutch, pressure plate, bell housing, clutch spacer listed in Table A5.7 (X1.28)
- (2) Use driveshaft listed in Table A5.7, (X1.37)

6.9 Special Engine Measurement and Assembly Equipment

- (1) Items routinely used in laboratory and workshop are not included.
- (2) Use any special tools or equipment shown in the 2012 Explorer service manual for assembly.
- (3) A list of these tools is provided in Table A5.8.
- (4) Complete any assembly instructions not detailed in Section 7 according to the instructions in the 2012 Explorer Service Manual.

6.9.1 Piston ring positioner

- (1) Use the piston ring positioner to locate the piston rings from the cylinder block deck surface by 38 mm (Figure A7.1).

(2) This allows the compression rings to be positioned in a consistent location in the cylinder bore for the ring gap measurement.

6.9.2 Piston Ring Grinder

- (1) A ring grinder is required for adjusting ring gaps.
- (2) A suitable ring grinder is suggested in [See 8.18.2](#).

7. Reagents and Materials

7.1 Degreasing Solvent

7.1.1 Use only mineral spirits meeting the requirements of Specification D235, Type II, Class C for Aromatic Content (0 % to 2 % by volume), Flash Point (61 °C, min) and Color (not darker than +25 on Saybolt Scale or 25 on Pt-Co Scale). (**Warning**—Combustible. Health hazard.) Obtain a Certificate of Analysis for each batch of solvent from the supplier.

7.1.2 Chemtool B-12 (**Warning**—Combustible. Health hazard.) (X1.34)

7.2 Organic Solvent

7.2.1 Penmul L460-- (**Warning**—Combustible. Health hazard.)^{5,7} (X1.20)

7.3 Test Fuel

7.3.1 Use only EEE **lube certification** fuel^{6,7} (**Warning**—Flammable. Health Hazard.) (X1.6)

7.4 Test Oil

7.4.1 A minimum quantity of 23 L (6 gal) required.

7.5 Engine Coolant

7.5.1 Shell Zone Dex-Cool concentrate mixed 50/50 with deionized water (X1.33)

7.6 Ultrasonic Cleaner

7.6.1 ~~Tierra Tech ultrasonic solution 7 and B (X1.17).~~ **Brulin US Solution 815 GD and 815 QR-DF**

7.7 Parts Cleaning Soap

7.7.1 NAT-50 or PDN-50 are acceptable. (**Warning**—Health hazard.) (X1.21)

7.8 Sealing Compounds—Use a silicon-based sealer as needed on the contact surfaces between the rear seal housing and oil pan and the front cover and cylinder block, cylinder head and oil pan.

7.8.1 Use Motorcraft Gasket Maker (TA-16) or equivalent between the 6th intake and exhaust camshaft cap and the cylinder head.

7.8.2 Use silicon-based sealer sparingly since it can elevate the indicated silicon content of the used oil.

NOTE 3—Non-silicon liquid or tape thread sealers can be used on bolts and plugs.

7.9 Engine Build Up Oil

7.9.1 EF-411 (*1) used as engine assembly oil (X1.13)

⁵ Penmul L460 can be obtained from Penetone Corp., P.O. Box 22006, Los Angeles, CA 90022

⁶ General information concerning EEE fuel, including availability, can be obtained from the following: Haltermann Products, 1201 S. Sheldon Rd., P.O. Box 249 Channelview, TX 79530-0429

⁷ If you are aware of alternative suppliers, please provide this information to ASTM International Headquarters. Your comments will receive careful consideration at a meeting of the responsible technical committee, which you may attend.

*1 The sole source of supply of this product known to the committee at this time is Exxon-Mobil Oil Corp., Attention Illinois Order Board, P.O. Box 66940, AMF O'Hare, IL 60666, USA.

8. Preparation of Apparatus

8.1 Engine Parts Cleaning

8.1.1 Rinse parts with parts cleaning soap, NAT-50 or PDN-50 before putting into ultrasonic cleaner.

8.1.2 Clean the cylinder block, cylinder heads, pistons, oil pan and front cover using ~~Tierra Tech model MOT500NS~~ ultrasonic parts cleaner or similar apparatus. (X1.16).

8.1.3 The ultrasonic parts cleaner solution, ~~Ultrasonic solution 7 and B~~ **Brulin US Solution 815 GD and 815 QR-DF**, is also available from **Stevenson Oil & Chemical Corporation** ~~Tierra Tech~~.

8.1.4 Put all of the following components into the ultrasonic parts cleaner for 30 min:

- (1) Cylinder block ~~with main bearings~~. Oil jets **and main bearings** are removed.
- (2) Bare pistons without wristpins (The piston compression and oil rings are removed from each piston prior to going into the ultrasonic cleaner; they will get replaced with a new set)
- (3) Bare cylinder head (No valve train components)
- (4) OHT oil pan
- (5) Front cover

8.1.5 Ultrasonic parts cleaner details

- (1) Add solution once that in the ultrasonic cleaner reaches a minimum of 60 °C (140 °F).
- (2) DO NOT add the degreasers until the ultrasonic mixture has reached a temperature of 60 °C (140 °F).
- (3) Add ~~20.82 L (5.5 gal) of ultrasonic solution 7~~ **25.25 L (6.67 gal) of Brulin 815 QR-DF**
- (4) Add ~~1.83 L (0.5 gal) of ultrasonic solution B~~ **25.25 L (6.67 gal) of Brulin 815 GD**
- (5) Change the soap and water solution at least after every 25 h of use.

Note 2: The solution shown above is based upon the MOT-~~400~~NS model (1900 L capacity). Quantities will be different for a different size unit. **50/50 Brulin US Solution of 815 GD and 815 QR-DF with a volume fraction of 12.5 %**.

8.1.6 Cleaning procedure details

8.1.6.1 After 30 min, the parts are removed and immediately sprayed with hot water, then solvent and left to air dry.

8.1.6.2 The remaining components are spray-cleaned with degreasing solvent then blown out with pressurized air and left to air dry:

- (1) Camshafts and all valve train.
- (2) Intake manifold/ Throttle body (not being separated)
- (3) Fuel pump housing with piston.
- (4) Vacuum pump and oil screen.
- (5) Intake and outlet of the turbocharger are lightly wiped down with solvent.
- (6) The oil screen is also cleaned. (We don't clean the inside of the turbocharger)
- (7) The carbon build up on the injectors is wiped off
- (8) Oil Pump
- (9) VCT solenoids are sprayed with solvent.
- (10) Valve Cover
- (11) Turbo charger oil lines
- (12) Oil separator (PCV housing on the cylinder block)
- (13) Oil pick up tube
- (14) Oil squirters/jets
- (15) Crankshaft
- (16) Rods and pins
- (17) All valvetrain
- (18) The test batch camshaft sprockets and crankshaft gear.
- (19) The test batch timing chain is cleaned as described in the Timing Chain Cleaning Procedure (See 8.21.1).

8.2 *Cylinder Deglazing*

8.2.1 Use a flexible cylinder hone Flex Hone Model: GB33432 and Pneumatic Honing Drill, Westward 1/2 Reversible Air Drill, Model: 5ZL26G to deglaze the cylinder walls. (X1.18 and X.1.19)

8.3 *PCV Valve Flow Rate Device*

- (1) Use this device to verify the flow rate of the PCV valve before the test and measure the degree of clogging after the test.
- (2) Fabricate the device according to the details shown in Fig. 1.
- (3) The device shall have a full scale accuracy of 5 % and a resolution of 0.05 L/s.

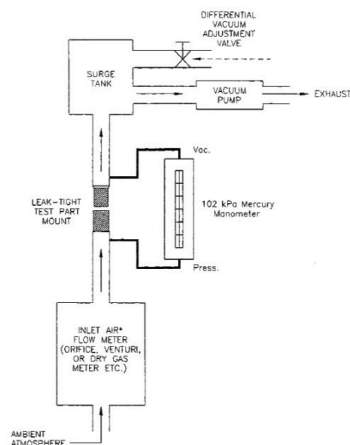

NOTE 1—The inlet flow meter must calibrate to within 5 % of the standard (pre-calibrated) orifices at the pressure differentials stamped on the orifices.

FIG. 1 PCV Valve Flow Test Apparatus

8.4 Miscellaneous Engine Components-Preparation

8.4.1 Engine Build-Up and Measurement Area-Environment

- (1) The ambient atmosphere of the engine buildup and measurement areas shall be reasonably free of contaminants.
- (2) A relatively constant temperature (within ± 3 °C) is necessary to ensure acceptable repeatability in the measurement of parts dimensions.
- (3) To prevent moisture forming on cold engine parts that are brought into the buildup or measurement areas, maintain the relative humidity at a nominal maximum of 50 %.

8.5 Throttle Body:

8.5.1 Clean the butterfly and bore of the throttle body with carburetor cleaner (Chemtool B12, X1.34) and air-dry before each test.

- (1) Do not disassemble the throttle body as this will cause excessive wear on the components.
- (2) ~~The idle air screw can be removed for the cleaning process.~~
- (3) ~~Fully close the idle air screw during test operation.~~
- (4) There is no specific life for the throttle body. However, the clearance between the bore and the butterfly will eventually increase and render the body unserviceable.
- (5) When the clearance becomes too great to allow control of speed, torque, and air-fuel ratio, discard the throttle body.

8.6 PCV Valve Cleaning and Measurement

8.6.1 **PCV valve cleaning- Spray the inside of the PCV valve with Chemtool B12 until solvent comes out clear.**

8.6.2 Measure and record the flow rates of the PCV valve with the calibrated flow device described in Fig. A8.19.

- (1) Measure the flow rate at 27 kPa and 60 kPa vacuum.
- (2) Because of the hysteresis in the PCV valve spring, make the vacuum adjustments in one direction only.
- (3) Measure the flow rate twice and average the readings.
- (4) Reject any PCV valve that does not exhibit an average flow rate of 36 L/min to 54 L/min at 27 kPa and 19 L/min to 21 L/min at 60 kPa

8.7 Water Pump Drive System—Use only the pulleys and belt provided in the test stand set-up parts list (Table A5.6), crankshaft pulley, water pump and pulley, tensioner, and six groove belt shown in Fig. 2.

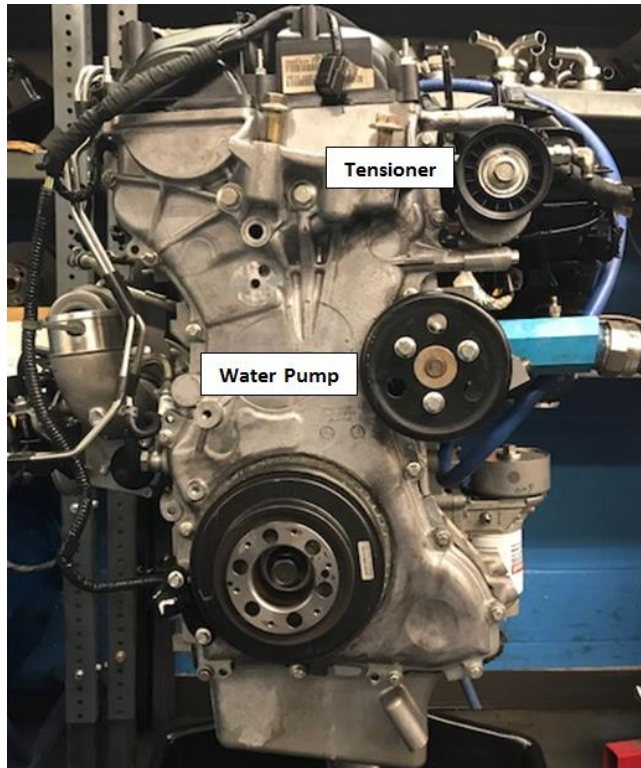

FIG. 2 Water Pump Drive Arrangement

8.8 Oil Separators—Clean with degreasing solvent (See 7.1) and allow to air-dry.

8.9 Assembling the Test Engine-Preparations—Use the long block obtained from the supplier (X1.1).

(1) ~~If this is the first test on a new engine, Disassemble the long block in accordance with the 2012 Explorer workshop manual.~~

(2) Required new parts and reusable parts are listed in Table A5.

8.10 Parts Selection—Instructions concerning the use of new or used parts are detailed in See 6.2 - 6.6.

8.11 ~~Sealing Compounds—Use a silicon based sealer as needed on the contact surfaces between the rear seal housing and oil pan and the front cover and cylinder block, cylinder head and oil pan.~~

(1) ~~Use Motorcraft Gasket Maker (TA-16) or equivalent between the 6th intake and exhaust camshaft cap and the cylinder head.~~

(2) ~~Use silicon based sealer sparingly since it can elevate the indicated silicon content of the used oil.~~

~~NOTE 3—Non silicon liquid or tape thread sealers can be used on bolts and plugs.~~

8.12 Gaskets and Seals—Install new gaskets and seals during engine assembly.

8.13 Block Preparations—Inspect block, including oil galleries for debris and rust.

(1) Remove any debris or rust that is found.

(2) Remove oil gallery plugs.

(3) Removal of coolant jacket plugs is left to the discretion of the laboratory.

8.14 *Deglazing Procedure:* Deglazing is performed after ultrasonic cleaning under the following conditions to

achieve a 9 μm (Ra) to 13 μm (Ra) surface finish and $30^\circ \pm 5^\circ$ degree crosshatch:

- (1) Mount the engine block in an engine stand or suitable fixture so it is secure and will not move during deglazing operation.
- (2) Rinse cylinder bores with degreasing solvent.
- (3) Deglaze cylinder bores using drill and hone shown in **Figs. 3 and 4**
- (4) Run the drill at 500 r/min horizontal drill speed for 25 to 35 vertical strokes over elapsed time of 20 s to 25 s. There should be a steady supply of lubricant supplied during each stroke.
- (5) Use a 50/50 ratio of degreasing solvent and EF411, as the hone lubricant.
- (6) Clean cylinders after honing deglazing with warm/hot water or hot water and detergent (Tide is suitable) using a brush, then oil cylinders with EF411.
- (7) Replace ball hone after deglazing 24 engine blocks



Fig. 3: Pneumatic Honing Drill

Pneumatic Honing Drill

Brand: Westward
 1/2 Reversible Air Drill
 Model: 5ZL26G
 Speed: 500 r/min
 620 kPa (90 psig), max



Fig. 4: Cylinder Hone

Flexible Cylinder Hone

Flex, Model: ~~GB33432~~ GB31232
 Bore Diam.: ~~95.25 mm (3.75 in.)~~ (3.50 in.)
 Abrasive material: Silicon Carbide Grit

8.15 Crosshatch **Measurement Procedure:**

8.15.1 Apparatus

- (1) HatchView Software
- (2) USB microscope.
- (3) Computer System **Minimum** Requirements: Windows XP, Vista or Windows 7 (32 or 64 bit), an available USB 2.0 port is required for live “video” viewing.

8.15.2 Preparation:

- (1) Cylinder should be clean of any oil or residue from honing to maintain consistency of measurements.
- (2) Adjust focus of camera while face of the camera is placed against the cylinder wall.
- (3) Set camera resolution to 640x480 and 30 fps.
- (4) Use the identification feature available in the program to title the image with cylinder number and test number.

8.15.3 Measurement:

- (1) The measurement is taken at the rear most longitudinal position of each cylinder.
- (2) The measurement is taken at 38.1 mm (1.5 in.) down from the top of the cylinder deck. A ruler is used to measure.
- (3) The measurement is to range for 25° to 35° with a target of 30°

8.16 Crankshaft preparation

- (1) Clean the crankshaft (See 8.1)
- (2) Spray the crankshaft with degreasing solvent.
- (3) Measure the main journals and connecting rods journals (horizontal diameter, vertical diameter) bearing inside diameter and clearance and verify that they meet the service limits.
- (4) The crankshaft is polished with 400 grit **aluminum oxide** utility cloth while it is still lightly coated in degreasing solvent. **3M utility cloth has been found to be suitable.**
- (5) A final finish is given using 600 grit crocus cloth. The crankshaft is cleaned with degreasing solvent for the final time.

8.17 Piston and rod assembly

- (1) Clean the pistons according to See 8.1.
- (2) Measure piston, piston pin and pin rod hole diameters to ensure they meet service limits.
- (3) Install the pistons on the connecting rods per the procedure in the 2012 Explorer workshop manual.

8.18 Piston Rings

8.18.1 Ring Gap Adjustment:

- (1) The piston rings are cleaned and wiped with EF411 to get the factory coating off.
- (2) **The first ring is gapped to 1.651 mm (0.065 in.) and the second ring is gapped to 1.778 mm (0.070 in.).**
- (2) **Typically 1.651 mm (0.065 in) for the top ring and 1.778 mm (0.070 in) for the second ring gaps have been shown to produce acceptable blowby levels with the surface finish and crosshatch pattern achieved in See 8.14. However, the delta between the top and second ring should remain at .127mm (0.005 in).**
- (3) However, to achieve an average blowby of 65 L/min to 75 L/min, an adjustment may be necessary immediately before or after the 24 h measurement
- (4) **A 24 h blowby value of at least 70 L/min is recommended. The 24hr to 120 h blowby average must fall within 65 L/min to 75 L/min.**
- (5) Ring gap adjustments are not allowed once the test has resumed after the 24 h blowby reading. **This recommendation is included because the test will be invalid if the average blowby drops below 65 L/min after the 24 h reading.**
- (6) The ring placement is 38 mm (1.5 in.) from the deck, using piston ring setter (Fig. A7.1).

8.18.2 Piston Ring Cutting Procedure:

- (1) Cut the top and second compression ring gaps to the required gap using the Sanford Piston Ring Grinder. (X1.22) ring cutting burr (X1.24) rotated at a rated speed of 3450 r/min.
- (2) Remove equal amounts from both sides of the gap. Make final cuts on the down stroke only.
- (3) The ring is cut with a maximum increment of 0.125 mm until the desired ring gap is achieved.
- (4) After the rings are cut remove the ring from the cutting tool, debur using a Sunnen soft stone (X1.24) and wipe with a dry towel.

8.18.3 Installation:

- (1) Install the oil control rings and the compression rings on the pistons with the gaps located over the piston pin.
- (2) Position the gaps at approximately 180° intervals, with the top compression ring gap toward the rear.
- (3) Install the rings using a ring spreader tool, keeping the rings' surfaces parallel to the ring groove in the piston.
- (4) If any rings require replacement, then measure and record the new ring gap(s)

8.19 Cylinder Bore Measurements

- (1) Measure the cylinder bores with the bearing caps in place **and torqued.**

(2) Clean the bores with a dry rag. The bores shall be clean and dry when they are measured.

(3) Use a bore gage micrometer, along with the bore ladder (Fig. A.7.2), to determine the diameter of cylinders at the top, middle and bottom.

8.20 Assembling the Test Engine

8.20.1 Assemble the engine according to the instructions in the 2012 Explorer service manual unless specified herein.

8.20.2 Cylinder block

(1) The heater hose tube is removed from the block as shown in Fig. 5 and plugged with a 3.2 mm (5/8 in.) freeze plug coated in RTV.

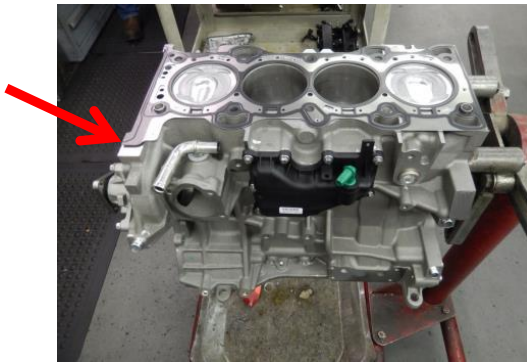

Figure 5: Cylinder Block Heater Hose Tube

8.20.3 Piston Installation

(1) Install piston and rod assemblies in proper cylinders, taking care to ensure rings are not damaged during installation.

(2) Wipe the cylinders with EF-411 (X1.13).

(3) Install the pistons and connecting rods with the notches facing the rear.

(4) Install the rod bearing caps and torque according to the procedure in the 2012 Explorer workshop manual.

8.20.4 Oil System Components

(1) All oil system components in the engine are production configuration with the exception of the oil pan and the oil pickup tube, shown in Fig. 6.

8.20.5 Cylinder Head Installation

(1) Obtain cylinder heads from a supplier listed in X1.28.

(2) Heads may be used for up to six tests, as long as they remain within service limits serviceable.

(3) Disassemble heads and inspect for any debris or other deleterious materials and remove as necessary.

(4) Clean the cylinder head in the Ultrasonic cleaner as described in See 8.1.

(5) Determine valve guide clearance at the top and middle of the heads on the transverse side of the guide.

(6) Reject any heads that exceed the service limits shown in the 2012 Explorer work shop manual.

(7) Measure and record intake and exhaust valve springs, spring free length, and spring load at a compressed height of 28.7 mm.

(8) Verify the compressed spring load is 460 N \pm 21 N. Reject any springs not meeting this criteria.

(9) Assemble the cylinder heads in accordance with the service manual. The valves are lapped before installation and new intake and exhaust valve seals are installed.

(10) Set the valve lash per the procedure in the workshop manual and record the valve lash.

8.20.6 Chain and Camshaft Installation Procedure

(1) Measure the test chain according to the Timing Chain Measurement Procedure (See 8.21.5) prior to installing it in the engine.

(2) Install camshaft and timing chain according to the procedure in the 2012 Explorer workshop manual.

(3) If using the Ford camshaft alignment tool (Ford P/N 303-1565) (X1.25) be sure not to let it bind in slots at the rear of the camshafts. It should be loose after the timing chain installation is complete.

(3a) Be sure camshaft positioning tool is flat before installing.

(4) Use a spanner on the harmonic balancer or a flywheel lock to hold the crankshaft.

(4a) Alternate method, the crankshaft positioning crankshaft TDC timing peg (Ford P/N 303-507) (X1.26) can be used to

hold the crankshaft in place while performing this installation.

(5) Install the timing chain with the lettering on the black link facing forward. This will ensure the chain is installed in the same orientation if/when it is removed and reinstalled during the test.

(6) Coat the timing chain with test oil every time it is installed in the engine other than the pre break in installation.

(6a) Coat the timing chain with EF-411 when it is first installed before break in.

(7) Install the chain tensioner and guides according to the 2012 Explorer workshop manual.

(8) After the tensioner is installed and the pin is pulled from the tensioner to release the tensioner arm, do not move or apply any force to the tensioner arm.

8.20.7 Balance Shaft Housing

(1) Do not install the balance shaft housing; it cannot be used with the test oil pan.

(2) Remove the balancer and plug the oil passage with a CFM Balance Shaft Delete Kit (Part number 1-0180).

8.20.8 Oil Pan and Baffle

(1) Install oil pan baffle to the oil pan as shown in Fig. 6.

(2) Install the oil pan according to the procedure in the 2012 Explorer service manual.

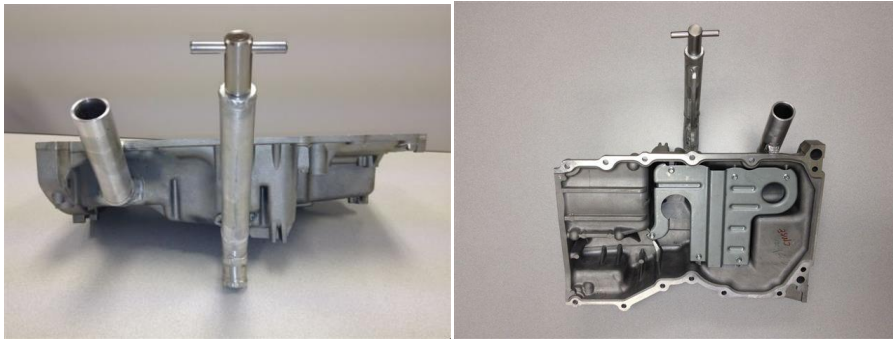

Oil Pan
Fig. 6

8.20.9 Water Pump, Water Pump Drive

(1) Install the water pump and pulley, the crankshaft pulley, and tensioner according to the 2012 Explorer service manual.

(1a) These are the only components needed to drive the water pump. All other production front end accessory drive components do not need to be installed.

(2) Do not use the engine to drive any external engine accessory other than the water pump.

(3) Pull back tensioner and install water pump drive belt as shown in Fig. 7.

(4) Ensure that there is a minimum contact angle of 20° between the drive belt and the water pump pulley.

FIG. 7 Water Pump Drive Arrangement

8.20.10 Engine cooling system

(1) Coolant inlet and outlet housings available from the supplier listed in X1.28.

(2) Do not install the thermostat.

(3) Plumb the external coolant system, see Figs. A9.1 and A9.2.

(4) Use coolant flow meter with an accuracy of $\pm 1\%$.

(5) A radiator cap is used to limit system pressure to 105 kPa.

(6) Pressurize the coolant system to 70 kPa \pm 10 kPa at the top of the coolant reservoir

(7) Control the engine coolant flow rate and outlet temperature in accordance with the specifications listed in [Table 4](#).

(8) Cyclic ramping specifications are detailed in [Table 5](#).

(9) Prior to running each reference calibration test, inspect the engine coolant system components, external to the engine, and clean as needed.

(10) The coolant side of the system typically doesn't need cleaning, but the process water side may need routine cleaning.

(10a) While a specific flushing technique is not specified, the process should include use of a commercial descaling cleaner.

8.20.11 Cylinder block oil separator

(1) Install a dummy PCV valve (PCV valve with the internal components removed) in the oil separator on the side of the engine block **and crankcase pressure is measured in this location.**

(2) A functional PCV is located at the stand in the external ventilation system, ~~and crankcase pressure is measured in this location.~~

8.20.12 Oil cooling system

(1) Use the production oil cooler (BB3Z-6A642-A) attached to the oil filter adapter.

(2) Use process water on the coolant side to control the oil temperature.

(3) Control oil temperature by a valve on the process water inlet line to adjust the flow of process water through a feedback loop from the 'oil in **gallery**' thermocouple location.



Fig. X Oil Gallery Temperature Control System

8.21 Timing Chain

8.21.1 New chain preparation

- (1) Place a new timing chain into an ultrasonic bath with degreasing solvent for 20 min.
- (2) Remove the chain from the ultrasonic cleaner and dip into room temperature degreasing solvent to cool chain.
- (3) Dip the chain in heptane or solvent 142 to prevent rust.
- (4) Oil chain by dipping in EF-411.
- (5) Install the chain in the engine for engine break in

8.21.2 After break in

- (1) After break in remove the chain from the engine.
- (2) Place the chain into an ultrasonic bath with degreasing solvent for 20 min.
- (3) Remove the chain from the ultrasonic cleaner and dip into room temperature degreasing solvent to cool chain.
- (4) Dip the chain in heptane or solvent 142 to prevent rust.
- (5) Oil chain by dipping in EF-411.
- (6) Hang the chain to let excess oil run off and let the chain cool off for a minimum of 2 h in the metrology lab before starting the after break in measurement procedure. This will allow the temperature of the chain to stabilize.

(7) Measure timing chain see 8.21.5

8.21.3 Chain installation after break in

- (1) Dip the chain in degreasing solvent to remove EF-411 then dip the chain in new test oil.
- ~~(2) Install the chain in the engine for the start of test.~~
- (2) Reinstall the chain per section 8.20.6

(Note: Do not clean the timing chain if it is removed during the test for an engine repair)

8.21.4 End of test

- (1) At the end of test, remove the timing chain from the engine.
- (2) Place the timing chain into an ultrasonic bath with degreasing solvent for 20 min.
- (3) Remove the chain from the ultrasonic cleaner and dip into room temperature degreasing solvent to cool chain.
- (4) Dip the chain in heptane or solvent 142 to prevent rust.
- (6) Oil chain by dipping in EF-411.
- (7) Hang the chain to let excess oil run off and let the chain cool off for a minimum of 2 h in the metrology lab before starting the measurement procedure. This will allow the temperature of the chain to stabilize

(8) Measure timing chain see 8.21.5

8.21.5 Chain measurement - general

- (1) The timing chain is measured two times during the test; after the 8 h engine break in and at the end of the test.
- (2) Use the Motorized chain measurement apparatus, MCMR 1000 (X1.31) shown in Fig. 8
- (3) Parts list show in A5.8



Fig.8: Chain Measurement Apparatus

8.21.6 Chain measurement - rig calibration

- (1) Check calibration on the measurement apparatus before every test chain measurement using a reference chain and ensure the reference chain measurement is within $\pm 25.4 \mu\text{m}$ (± 0.001 in.) of the previous measurement then proceed to next step.
- (2) If reading is larger, then investigate source of error.
- (3) Adjust the rig to achieve a measurement within $25.4 \mu\text{m}$ (0.001 in.) of the last correct reading.
- (4) The lab needs to have a single new unused chain that is used as a reference chain and this chain is only used for calibrating the measurement apparatus. **The same reference chain should be used when calibrating the chain measurement apparatus. The reference chain should be stored in metrology and lightly oiled with EF 411.**

8.21.7 Chain measurement - procedure

- (3) Orient the sprockets of the measurement apparatus such that they are aligned with their alignment orientation marks.
- (4) Install chain on measurement apparatus with the "key" link in the standard (aligned) location.
- (5) Ensure that the USB digital interface cable between the indicator and the computer is connected and that the first cell of the spreadsheet is selected into which the data will begin being entered.
- (6) Energize the drive motor on the chain measurement apparatus and run until a minimum of 30 chain lengths worth of reading have been captured (207 sprocket revolutions)
- (7) When complete, examine the averages for the three measurement ranges and verify the total range does not exceed ± 0.008 mm (± 0.0003 in.); if it does, repeat the measurement by overwriting the data.

8.21.8 Chain measurement – results (see 11.1.1)

- (1) Determine the averages for the three measurement ranges
- (2) Determine the average of those three subset average measurements
- (3) This average is used as the final chain measurement in the calculation below:

Chain elongation = 2 x (final average measurement-initial average measurement)/nominal chain length. The nominal chain length is 43.125 in.

8.22 Test stand installation

8.22.1 Functions that are to be performed in a specific manner or at a specific time in the assembly process are noted.

8.22.2 Test engine

- (1) Mount the engine on the test stand so that the flywheel friction face is $0.0^\circ \pm 0.5^\circ$ from vertical.
- (2) Four motor mounts are used (Quicksilver part# 6628-A) as shown in Fig. A9.3, Fig. A9.4, and Fig. A9.5.
- (3) Drawings of the mount brackets are shown in X2.1 and X2.2.
- (4) The engine must be at $0.0^\circ \pm 0.5^\circ$ roll angle.

8.22.3 Flywheel

- (1) The flywheel bolts get lightly coated with Loctite 565 to prevent any oil from seeping out of the holes.
- (2) Torque the flywheel 108 N·m to 115 N·m.
- (3) Obtain the flywheel from the supplier (see X.1.28).

8.22.4 Clutch and pressure plate

- (1) Obtain the clutch, pressure plate and spacer from the supplier (see X1.28).
- (2) Put the flat side on the clutch toward the engine.
- (3) The spacer goes between the flywheel and pressure plate.
- (4) Torque the pressure plate bolts to 25 N·m to 33 N·m.
- (5) Each clutch gets replaced every 6 runs.

8.22.5 Driveline

- (1) The driveline is greased every test.
- (2) Driveline specifications:
 - (2a) Driveline Degree: $1.5^\circ \pm 0.5^\circ$
 - (2b) 595 mm \pm 13 mm installed length from flange-to-flange

Comment [JS2]: Add optional flywheel locking tool. Add to annex

- (2c) 1410 series flanges
- (2d) 69.9 mm (2.75 in.) pilot
- (2e) 95.25 mm (3.75 in.) bolt circle
- (2f) 88.9 mm (3.50 in.) by 2.11 mm (0.083 in.) stub and slip

8.22.6 Dynamometer: Use Midwest dynamometer model 1014A.

- (1) Dynamometer can be purchased from the vendor listed in [X1.27](#)

8.22.7 Exhaust System and Gas Sampling Fittings:

- (1) A typical exhaust system, and fittings for backpressure probes, O₂ sensors and thermocouple are illustrated in [Fig. A9.8](#).
- (2) Exhaust components should be constructed of either solid or bellows pipe/tubing.
- (3) Other type flexible pipe is not acceptable.
- (4) The backpressure probes can be used until they become unserviceable.
- (5) If the existing probes are not cracked, brittle, or deformed, clean the outer surface and clear all port holes.
- (6) Check the probes for possible internal obstruction and reinstall the probes in the exhaust pipe.
- (7) Stainless steel probes are generally serviceable for several tests; mild steel probes tend to become brittle after one test.
- (8) Exhaust gas is noxious.
- (9) (**Warning**—Any leaks in the connections to the sample probe will result in erroneous readings and incorrect air-fuel ratio adjustment.)

8.22.8 Fuel Management System

- (1) The fuel injectors can be used for 6 tests.
- (2) Inspect the O-rings to ensure they are in good condition and will not allow fuel leaks, replace if necessary.
- (3) Install the fuel injectors into the fuel rail and into the cylinder head.
- (4) Fuel system schematic shown in [Fig. 9](#)

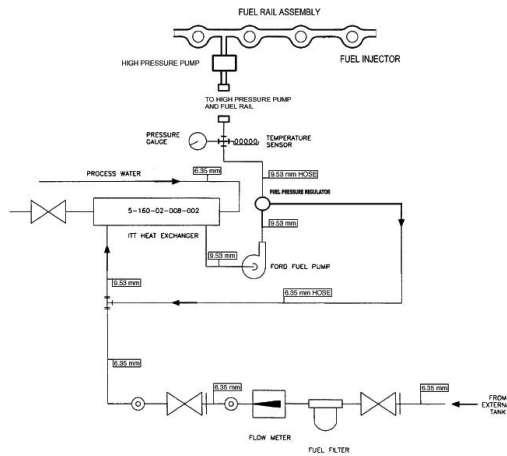

Fig. 9
Fuel System Schematic

8.22.9 Powertrain Control Module

- (1) The engine uses a PCM provided by Ford Motor Company to run this test.
- (2) The PCM contains a calibration developed for this test
- (3) Use a PCM that contains calibration [U5J0110D1VEPfm13_78_2](#).
- (4) The PCM module is available from the supplier listed in [X1.32](#).

(5) The PCM power shall come from a battery $13.5\text{ V} \pm 1.5\text{ V}$ or a power supply that does not interrupt/interfere with proper PCM operation.

(6) Connect the PCM battery/power supply to the engine wire harness with an appropriate gage wire of the shortest practical length so as to maintain a dc voltage of 12 V to 15 V and minimize PCM electrical noise problems.

(7) Ground the PCM ground wire to the engine.

(8) From the same ground point, run a minimum two gage wire back to the battery negative to prevent interruption/interference of the PCM operation.

(9) The power supply can also be used for the Lambda measuring devices.

8.22.10 Spark Plugs

(1) Install new Motorcraft CYFS-12-Y2 spark plugs.

(2) Spark plugs come pre-gapped.

(3) Torque the spark plugs to 9 N·m to 12 N·m.

(4) Do not use anti-seize compounds on spark plug threads.

8.22.11 Crankcase Ventilation System

(1) The crankcase ventilation system is a closed system allowing blowby to be vented from the crankcase and drawn into the intake manifold.

(2) The metal parts of the crankcase ventilation system get flushed with carburetor cleaner (Chemtool B12) or any equivalent solvent after every test, then blown out with pressurized air and are left to air dry. **Ensure carburetor cleaner is dry before test start.**

(3) All the hoses (i.e. tygon) get replaced every test.

(4) If using a smooth bore Teflon braided stainless steel hose, these can be reused after cleaning in an organic degreaser (Pennul L460).

(5) A schematic of the crankcase ventilation system (Fig. 10), and a photograph (Fig. 11) are shown.

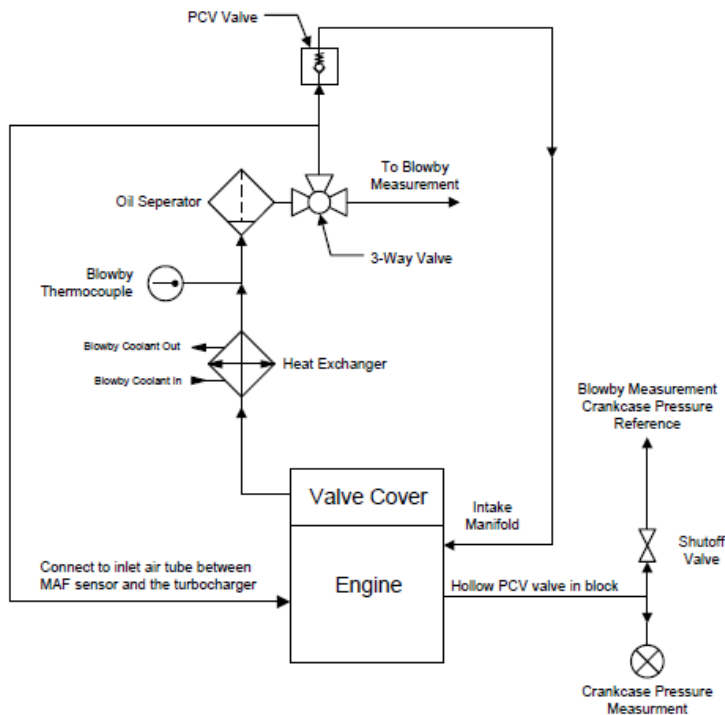

Fig. 10: Schematic - Crankcase Ventilation System

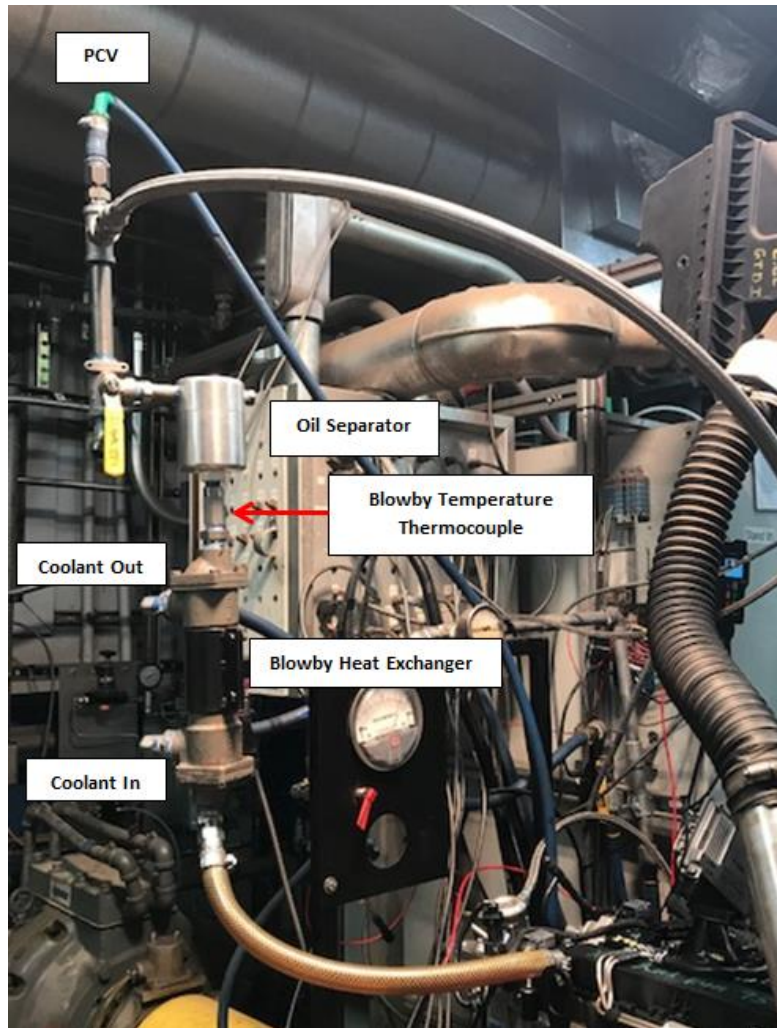

Fig. 11 Crankcase Ventilation System

8.22.11.1 System description

- (1) Blowby flows through the oil drain back passages in cylinder block and head and through the front cover and out through the camshaft cover.
- (2) The blowby heat exchanger and oil separator prevents loss of oil, fuel and water into PCV system.
- (3) A typical heat exchanger cooling system is shown in [Fig. A9.6](#).
- (4) The PCV valve flows approximately 120 L/min. Blowby flowrate is 65 L/min to 75 L/min.
- (5) When excessive plugging of the PCV valve occurs or there is excess blowby, the blowby is vented to the fresh air tube after the mass air flow sensor.

(6) A dummy PCV valve (PCV valve with the internal components removed) placed in the stock PCV valve location in the block-mounted oil separator is used for crankcase pressure measurement.

8.22.12 Blowby Heat Exchanger and Oil Separator

- (1) Use ITT Heater exchanger S-160-02-008-002 (X1.8) and Moroso oil separator, Part number 85487 (X1.29).
- (2) Disassemble and soak both in Penmul L460 (X1.20) for 24 h.
- (3) Rinse with hot water, then rinse a final time with degreasing solvent and let air dry.

8.22.13 Intake Air Components

- (1) Install the fresh air tube, air cleaner assembly, and new air filter.
- (2) Modify the air cleaner assembly to accept fittings for inlet air temperature thermocouple and pressure tap as shown in Fig. A2.12.
- (3) The excessive blowby tube is shown connected to the fresh air tube after the MAF sensor.
- (4) Use the 2012 Explorer fresh air tubes, or fresh air tubes can be fabricated but must be 1040 mm \pm 25 mm from the MAF sensor to the turbocharger inlet.

8.22.14 Water to Air Turbocharger Intercooler

- (1) Use water to air intercooler (A9.5) capable of achieving the required air charge temperature (Table 4) and an average system pressure loss less than 3 kPa in both stages
- (2) The intercooler accumulates significant amounts of blowby condensate during each test.
- (3) The air side of the intercooler must be spray cleaned with degreasing solvent, rinsed with hot water and left to air dry before each test.
- (4) Use commercial Aqua Safe descaler to clean the water side.

8.22.14.1 Intercooler Tubing

- (1) Fabricate the intake air system with 51 mm ID stainless steel tubing from the turbocharger to the intercooler and 64 mm ID stainless steel tubing from the intercooler to the throttle body.
- (2) The tubing length is not specified but should be the appropriate length to achieve the required air charge temperature and system pressure loss.
- (3) Locate the MAPT sensor 305 mm \pm 25 mm from the intake surface of the throttle body and the intake air charge temperature thermocouple 25 mm downstream from the MAPT sensor.
- (4) The post-intercooler turbo boost pressure measurement probe should be placed a minimum of ~~254~~ 305 mm (12 in.) upstream from the MAPT sensor.
- (5) The pre- intercooler turbo boost pressure measurement probe should be placed a minimum of ~~254~~ 130 mm (42 5 in.) downstream from the turbocharger outlet.
- (6) Typical installation is shown in Fig. 12, the measurements can be seen in Fig. A2.13.

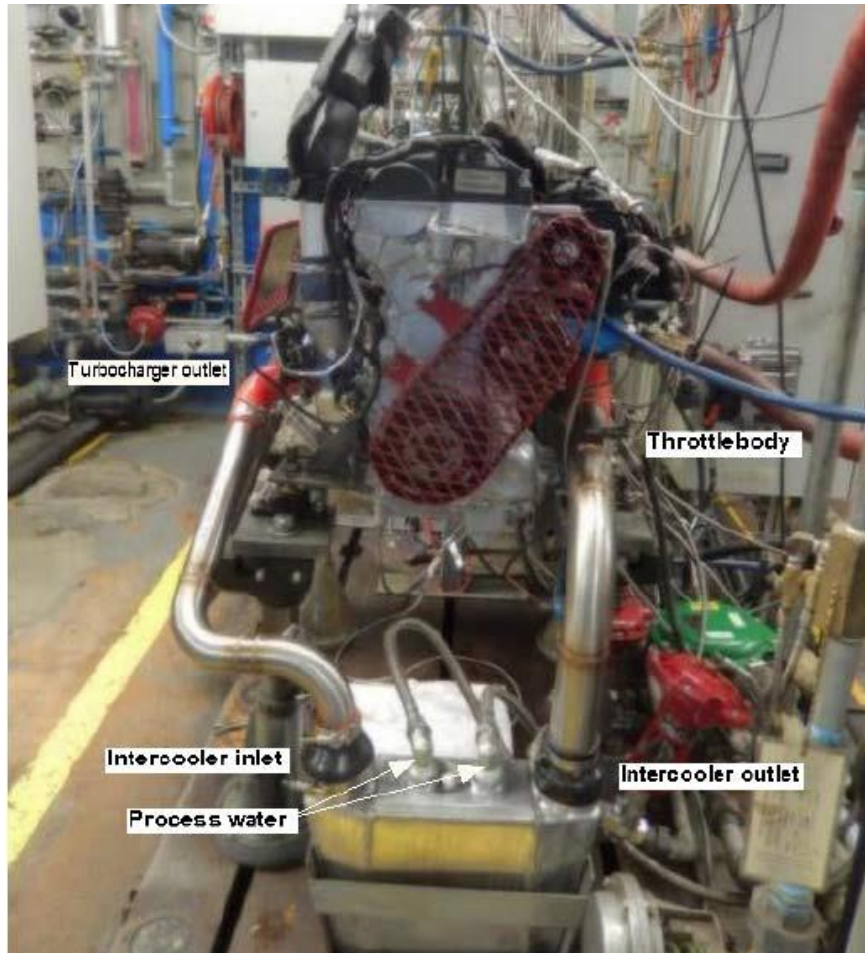

Figure 12, Typical Intercooler Installation

8.22.15 External Hose Replacement

- (1) Inspect all external hoses used on the test stand and replace any hoses that have become unserviceable.
- (2) Check for internal wall separations that could cause flow restrictions.
- (3) Check all connections to ensure security.

8.22.16 Wiring Harness

- (1) There are two wiring harnesses used on the test stand, a dynamometer harness that connects to the stand power and PCM and an engine harness.

- (2) Obtain the dynamometer wiring harness and engine wiring harness from the supplier listed in [X1.28](#), [A9.2](#).

8.22.17 Electronic Throttle Controller

- (1) Throttle is controlled using simulated accelerator pedal position signals.
- (2) The dynamometer wiring harness is supplied with an Accelerator Pedal Position jumper cable with un-terminated pigtail leads.
- (3) The test laboratory must connect two voltage command signals, Acc Pos Sensor 1 and Acc Pos Sensor 2, to the Accelerator Pedal Position jumper cable.
- (4) The voltage control ranges for each signal are shown in [Table 1](#).
- (5) The wiring schematic and pin-out description for this connection is shown in [Fig. 13](#).
- (6) The voltage signals must be run through a voltage isolator otherwise interference will occur between the lab DAC system and the engine ECU and throttle control will be erratic.

Table 1: Accelerator Position Sensor Control Ranges

Command Signal	Operating Range	Min Signal (Idle)	Max Signal (WOT)
Acc Pos Sensor 1	0 Vdc to 5.0 Vdc	0.75 Vdc (15 %)	4.25 Vdc (85 %)
Acc Pos Sensor 2	0 Vdc to 2.5 Vdc	0.375 Vdc (15 %)	2.125 Vdc (85 %)

Note: Acc Pos Sensor 2 should always equal 50 % of Acc Pos Sensor 1

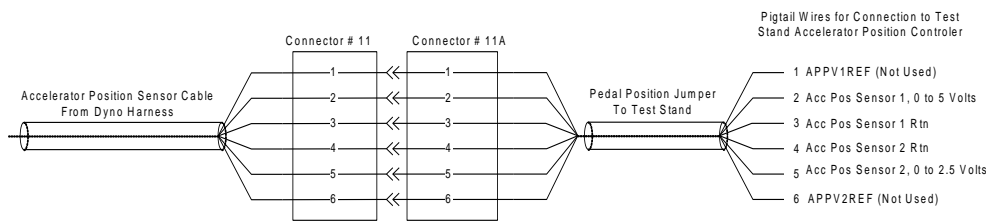

Figure 13: Accelerator Position Wiring Schematic

8.23 Engine Fluids (Supply/Discharge Systems)

8.23.1 Air supply system

- (1) Condition the intake air to $32\text{ }^{\circ}\text{C} \pm 0.5\text{ }^{\circ}\text{C}$, $11.4\text{ g/kg} \pm 0.8\text{ g/kg}$ humidity, and pressurized to $0.05\text{ kPa} \pm 0.02\text{ kPa}$.
- (2) 8.1.1 The supply system shall be capable of delivering 110 L/s of conditioned air, while maintaining the intake/air parameters detailed in [Table 4](#).
- (3) The test stand intake air duct system is not specified.

8.23.2 Dew Point

- (1) The dew point may be measured in the main system duct or at the test stand.
- (2) If the dew point is measured in the main system duct, verify the dew point periodically at the test stand.
- (3) Maintain the duct surface temperature above the dew point temperature at all points downstream of the humidity measurement point to prevent condensation and loss of humidity level.

8.23.3 Fuel System

- (1) A schematic diagram of a typical fuel supply system is shown in [Fig. 9](#).
- (2) Supply an excess volume of fuel to the fuel rail at all times.
- (3) The engine has a closed loop fuel system so excess fuel goes into the loop back to the heat exchanger.
- (4) Deliver the fuel to a high-pressure engine driven pump that boosts the pressure and supplies the fuel to the fuel rail.
- (5) Maintain the fuel temperature to the fuel rail below $50\text{ }^{\circ}\text{C}$.
- (6) To ensure good atomization supply to the high pressure fuel pump, maintain the fuel pressure to the high-pressure fuel pump above $448\text{ kPa} \pm 35\text{ kPa}$.
- (7) In addition, the fuel pressure should be constant at all steady-state conditions to ensure good speed, power, and air-fuel ratio control.

8.23.4 Fuel details

- (1) Approximately 1600 L of EEE Lube cert fuel (HF003) are required for each test.
- (2) Obtain EEE lube cert fuel (HF003) from the supplier listed in X1.6.
- (3) Laboratory storage tank may be filled with subsequent batches of fuel. A new batch of fuel may be added to existing fuel in the tank
- (4) The fuel batch that is reported for a test is the last fuel batch that was added to the tank before the test started.
- (5) A certificate of analysis accompanies each batch. **Maintain record of a certificate of analysis for each batch.**

8.23.5 Engine Oil:

- (1) The test oil sample shall be uncontaminated and representative of the lubricant formulation being evaluated.
- (2) A minimum of 16.35 L of new oil is required to complete the test.
- (3) A 20 L sample of new oil is normally provided to allow for inadvertent losses.

8.24 Measurement Instrumentation

8.24.1 Temperatures - general

- (1) Temperature measurement locations for the ten required temperatures are specified below in 8.24.1.1
- (2) Use thermocouples that are calibrated to ± 0.5 °C.
- (3) Use only OEM temperature sensors for EEC inputs.
- (4) All thermocouples, except the intake-air thermocouple, shall be premium and sheathed.
- (5) The intake-air thermocouple may be an open-tip type.
- (6) The diameter and length of the thermocouples shall be 3 mm by 100 mm.
- (7) Thermocouples, wires, and extension wires should be matched to perform in accordance with the special limits of error as defined in ANSI MC96.1.

8.24.1.1 Temperature measurement locations

- (1) Coolant inlet - Install the sensor in the coolant inlet on the engine (OHTVH-008-1) perpendicular to the run. Install sensor with the tip in the center of the stream of flow. (See Fig. A9.1).
- (2) Coolant outlet - Install the sensor in the coolant outlet on the engine (OHTVH-009-1) perpendicular to the run. Install sensor with the tip in the center of the stream of flow. (See Fig. A9.1).
- (3) Engine oil inlet- Install the tip of the sensor at the center of the flow stream in the external oil filter adapter (see Fig. A9.3) through the hole for the oil pressure switch (not used). Install a tee to accept this temperature sensor and attach the oil pressure line.
- (4) Engine oil outlet - Install the tip of the sensor at the center of the cross fitting attached to the side opposite from the engine oil inlet temperature sensor on the oil filter adaptor. The adapter needs to be modified with a 1/8 NPT hole to access the oil passage (see Fig. A9.3).
- (5) Intake air - Install the tip of the thermocouple midstream in the air cleaner box downstream of the filter (see Fig. A9.16). Insertion depth shall be 37 mm \pm 2 mm.
- (6) Fuel - Install the sensor in the fuel line before the high pressure pump.
- (7) Air Charge - Install the sensor in the intercooler outlet tube 25 mm \pm 2 mm downstream from the MAPT sensor. Locate the tip at the center of the flow. (See Fig. A9.4)
- (8) Pre-intercooler - Install a sensor in the tube between the turbocharger and the intercooler (See Fig A9.4).
- (9) Exhaust - Install a sensor 140 mm \pm 12 mm downstream on the exhaust flange (see Fig. 2.8)
- (10) Blowby gas - Install a sensor at the gas outlet of the blowby heat exchanger

8.24.1.2 Thermocouple calibration

- (1) Calibrate all thermocouples prior to a reference oil test.
- (2) The temperature measurement system shall indicate within ± 0.5 °C of the laboratory calibration standard.
- (3) The calibration standard shall be traceable to NIST.

Comment [JS3]: With oil density of 881 kg/m³
(4.32 gallons) (14400g)

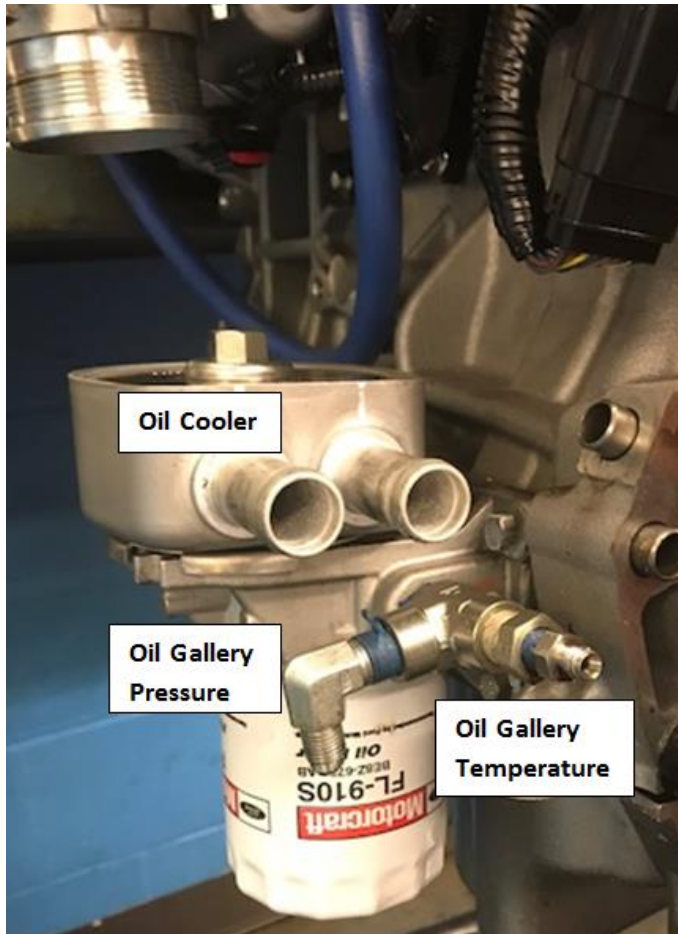

Figure A2.15 Oil cooler showing oil gallery pressure location

8.24.2 Pressures - general

- (1) Pressure measurement for each of the ten required parameters is detailed in the following sections, allowing reasonable opportunity for adaptation of existing test stand instrumentation.
- (2) However, the accuracy and resolution of the pressure measurement sensors and the complete pressure measurement system shall meet the requirements of the DACA-II document.
- (3) Replace pressure sensors that are part of the EEC system with only Ford specified equipment.

NOTE 5—Tubing between the pressure tap locations and the final pressure sensors should incorporate condensate traps, as indicated by good engineering practice. This is particularly important in applications where low air pressures are transmitted by means of lines that pass through low-lying trenches between the test stand and the instrument console.

8.24.2.1 Pressure measurement locations

- (1) Manifold Absolute Pressure (MAP) – Measure the manifold absolute pressure at the port downstream of the throttle-body

on the front side of the intake manifold (See Fig 2.13)

- (2) Engine oil - Measure oil pump pressure in the external oil filter adapter (see Fig. A2.16) through the hole for the oil pressure switch (not used). Install a tee to accept the temperature sensor and attach the oil pressure line.
- (3) Coolant—Measure engine coolant pressure at the top of the coolant reservoir as shown in Fig. A2.3.
- (4) Fuel – Measure fuel pressure in the lower pressure fuel line at the exit of the stand fuel pump.
- (5) Crankcase oil – Measure crankcase oil pressure at the dummy PCV valve in the cylinder block oil separator.
- (6) Exhaust gas - Measure the exhaust back pressure with the exhaust gas sampling probe located $76 \text{ mm} \pm 12 \text{ mm}$ downstream of the exhaust flange (see Fig. A2.8).
 - (6a) A sensor capable of absolute or gage measurement corrected with barometric pressure reading is recommended.
 - (6b) Install a condensate trap between the probe and sensor to accumulate water present in the exhaust gas.
- (7) Inlet air – Measure inlet air pressure in the air cleaner downstream of the air filter. (See Fig A2.12)
- (8) Pre-intercooler gas – Measure the pre-intercooler pressure with the exhaust gas sampling probe located $155 \text{ mm} \pm 25 \text{ mm}$ downstream of the turbocharger flange (See Fig 2.13)
- (9) Boost (post-intercooler) -Measure the post-intercooler pressure with the exhaust gas sampling probe located downstream of the intercooler and at least 305 mm upstream of the MAPT sensor. (See Fig 2.13)
- (10) Cylinder head oil– Measure cylinder head pressure at the oil gallery plug on the left side of the cylinder head next to the belt tensioner.

8.24.2.2 Pressure sensor calibration

- (1) Calibrate all pressure measurement sensors prior to a reference oil test.
- (2) The MAP pressure measurement system shall indicate within 0.1 kPa of the laboratory calibration standard.
- (3) All other pressure measurement systems shall conform to the guidelines in ASTM Research Report RR:D02-1218.22
- (4) The calibration standard shall be traceable to NIST

8.24.3 Flow rates – general

- (1) Flow rate measurement for each of the three required parameters is detailed in the following subsections.
- (2) With the exception of the engine coolant and blowby flow rates, measurement equipment is not specified for a given parameter.
- (3) This allows reasonable opportunity for adaptation of existing test stand instrumentation.

8.24.3.1 Flow rates - measurement

- (1) Engine coolant - Determine the engine coolant flow rate using a flowmeter with a mass flow-accuracy of $\pm 1 \%$ (see Fig. A2.3)
 - (1a) A suitable coolant micromotion Coriolis type flowmeter is available from the supplier in X1.38
 - (2a) Take precautions to prevent air pockets from forming in the lines to the pressure sensor.
 - (3a) Transparent lines or bleed lines, or both, are beneficial in this application.
 - (4a) Ensure that the manufacturer's requirements for orientation and straight sections of pipe are installed immediately up and down stream of the flowmeter.
- (2) Blowby heat exchanger coolant—Measure the total volumetric coolant flow rate through the blowby heat exchanger system as shown in (See Fig. A2.11). A suitable heat exchanger is available from supplier in X1.39
- (3) Fuel – Measure fuel flow in kg/hr on the low pressure fuel system before the high pressure engine fuel pump. A suitable fuel flowmeter is available from supplier in X1.38

8.24.3.2 Flow devices – calibration

- (1) Calibrate the flowmeters used in the measurement of both the engine coolant flow rate and blowby heat exchanger coolant flow prior to a reference oil test.
- (2) Calibrate the flowmeters as installed in the system at the test stand with test fluid.
- (3) Calibrate the flowmeters with a turbine flowmeter or by a volume/time method at Stage 1 and 2 operating conditions.

8.24.4 Blowby

- (1) Measure the blowby flow rate using the apparatus shown in Fig. 9.
 - (1a) The measurement system routes the blowby through an external, sharp-edged orifice and into the atmosphere.
 - (1b) Maintain crankcase pressure during operation of the system at $0.0 \text{ Pa} \pm 25 \text{ Pa}$ to minimize the potential for crankcase leakage.
 - (1c) Mount the orifice plate in a vertical position.
- (2) Determine the blowby flow rate by measuring the differential pressure drop across the sharp-edged orifice
- (3) An inclined manometer or differential pressure sensor is required for measurement of the differential pressure drop.
 - (3a) The differential pressure drop sensor shall have a range from 0 kPa to 1 kPa.
- (4) Fabricate the sharp-edged orifice assembly that is specifically designed for blowby flow rate measurement in strict compliance with the specifications that are available from the TMC.
- (5) Additional information on the orifice system can be obtained from the source listed in X1.28

- (6) The assembly contains five orifices.
 (6a) The 9.525 mm orifice is generally satisfactory for the range of blowby flow rate encountered.
 (7) The complete orifice assembly can also be purchased from the supplier listed in X2.1.11.

9. Test Procedure

9.1 Pre-test Procedure:

9.1.1 *Engine Break-In Procedure*—Run break-in schedule listed in Table 2.

- (1) Conduct the break-in before each test using the test oil.
- (2) The break-in procedure has 12 steps and is 8.25 h long.
- (3) There are 30 s ramps between steps that are counted as part of the 8.25 h.
- (4) Perform the flushes specified in the break-in procedure.

(4a) There are a total of 3 oil flushes as shown in Table 2; drain the oil for 15 min after each flush.

9.1.1.2 Install a pre-measured timing chain in the engine as listed in section 8.20.6 *Chain and Camshaft Installation Procedure*.

- (1) Coat the timing chain with EF-411 oil before break-in installation.

9.1.1.3 Charge the engine with 3600 g of test oil.

- (1) Prime and install a new oil filter.

9.1.1.4 The engine is now ready to start Step 1 of the break-in as listed in Table 2.

TABLE 2 Sequence CW Break-in Schedule

Step	Speed (r/min)	Load (N·m)	Time per stage (h:min)	Total Time (h:min)
Charge engine with 3600 g of new test oil and new primed oil filter				
1	Idle	0	0:30	0:30
Oil Flush 1 - Shut engine down and drain used test oil and remove oil filter. Add 3600 g of new test oil and install new primed oil filter				
Start engine and let idle for 5 min				
2	1500	38	0:30	1:00
3	2000	72	0:30	1:30
4	2500	111	0:30	2:00
5	3000	135	0:30	2:30
6	3000	150	3:15	5:45
7	2000	72	0:15	6:00
8	3250	155	0:15	6:15
9	3500	155	0:15	6:30
10	3750	155	0:15	6:45
11	4000	155	1:15	8:00
Bring engine to idle for 5 min and shut down.				
Oil Flush 2 - Shut engine down and drain used test oil and remove oil filter. Add 3600 g of new test oil and install new primed oil filter.				
12	Idle	0	0:15	8:15

Oil Flush 3- Shut engine down, drain used test oil and remove oil filter.

9.1.1.5 The controlled parameters during break-in are listed in Table 3.

- (1) All other controls are left wide open/free flowing.
- (2) The engine does not produce enough heat in the early steps to reach all target temperatures.
- (3) All controlled parameters are expected to be on target at the beginning of Step 4.

TABLE 3 Sequence CW Break-in Controlled Parameters

Break-in Controlled Parameters	
Coolant Out Temp.	85 ± 0.5 °C
Oil Gallery Temp.	100 ± 0.5 °C
Inlet Air Pressure	0.05 ± 0.02 kPa
Air Charge Temp.	37 ± 0.5 °C
Inlet Air Temp.	30 ± 0.5 °C

9.1.1.6 The laboratory ambient atmosphere shall be reasonably free of contaminants.

- (1) The temperature and humidity levels of the operating area are not specified.
- (2) A fan is allowed to divert air toward the turbocharger during break-in only.

9.1.1.7 The break-in allows an opportunity to check PCM system operation, check for leaks in the various systems and purge air from the cooling systems.

- (1) Specifications concerning the break-in procedure are shown in Table 2 and Table 3.
- (2) The engine start-up and shutdown procedures are detailed in 12.2.1 and 12.2.4 respectively.

~~9.1.1.8 The same test PCM calibration USJ0110D1VEPfn13_78_2 is used during break-in.~~

- ~~(1) Step 2 is a good time to check if the Lambda enrichment in the PCM calibration is working properly.~~

9.1.1.9 Perform Oil Flush 1 at the end of Step 1.

- (1) Drain the used oil and remove the used oil filter.
- (2) Let the oil drain for 15 min.
- (3) Charge the engine with 3600 g of new test oil.
- (4) **With a portion of this 3600 g of new test oil, prime a new oil filter and install it on the engine.**
- (5) **Charge the engine with the remaining new test oil for the final oil charge.**

The engine is now ready to start Step 2 of the break-in.

- (6) Continue to run the break-in until the end of Step 11 with the same oil charge.

9.1.1.10 Perform Oil Flush 2 at the end of Step 11 after the engine has idled for 5 min and shuts down.

- (1) Drain the used test oil and remove the used oil filter.
- (2) Let the oil drain for 15 min.
- (3) Charge the engine with 3600 g of new test oil.
- (4) **With a portion of this 3600 g of new test oil, prime a new oil filter and install it on the engine.**
- (5) **Charge the engine with the remaining new test oil for the final oil charge.**

The engine is now ready to start Step 12 of the break-in.

9.1.1.11 Oil Flush 3 is performed at the end of Step 12.

- (1) Drain the used test oil and remove the used oil filter.
- (2) Let the oil drain for 15 min.

9.1.1.12 Remove the timing chain for cleaning and 0 h measurement according to the *Timing Chain Cleaning Procedure* (see 8.21.2) and *Timing Chain Measurement Procedure* (see 8.21.7).

- (1) After measuring the chain, coat the chain in new test oil and install it back into the engine using the procedure described

in the *Timing Chain and Camshaft Installation Procedure* (see 8.20.6).

9.1.1.13 After the timing chain has been installed, measure 3600 g of test oil.

- (1) With a portion of this 3600 g of new test oil, prime a new oil filter and install it on the engine.
- (2) Charge the engine with the remaining new test oil for the final oil charge.

9.1.1.14 Start and run the engine at idle for 5 min, and then shut down the engine.

- (1) After the engine is shutdown for 20 min \pm 2 min, record the dipstick level in millimeters.
- (2) Rotate the calibrated dipstick 360 degrees while still in the oil pan to capture the oil level at the highest point.
- (3) Remove the dipstick to view the reading.
- (4) Break-in and the initial oil level measurement are now completed and test is ready to begin.
- (5) No makeup oil is added.

9.2 *Engine Operating Procedure:*

9.2.1 *Engine Start-up*—Use the following detailed procedure each time the engine is started.

- (1) Turn on the ignition, safety circuits, fuel management system, fuel pump, and the blowby coolant pump.
- (2) Ensure the intake-air supply duct is connected.

9.2.2 *Crank The Engine*—The engine should start within 4 s.

- (1) Since the engine has a crankshaft-driven oil pump, cranking oil pressure might be low.
- (2) If used, disable a low oil pressure ignition shutoff during engine starting to allow the engine to start even though the oil pressure is low.
- (3) The inclusion of this type switch could lead to excessive cranking time to start the engine.

9.2.2.1 If starting difficulties are encountered, the laboratory should not continue to crank the engine excessively.

- (1) Perform diagnostics to determine the reason the engine will not start (ignition problems, insufficient or excess fuel, and so forth).

(2) **Warning**— Excessive cranking times can promote additional fuel dilution of the test oil and can adversely affect the test. In addition to other precautions, do not attempt to pour gasoline into the intake-air horn.

9.2.3 *Test Start*—Conduct the test according to the operational parameters shown in Table 4.

- (1) The test stage and ramp order are shown in Table 5.

TABLE 4 Test Operational Parameters

Parameter	Units	Stage 1	Stage 2
Duration	min	120	60
Engine Speed	r/min	1550 \pm 5	2500 \pm 5
Torque	N·M	50 \pm 2	128 \pm 2
Oil Gallery Temperature	°C	50 \pm 0.5	100 \pm 0.5
Coolant Out Temperature	°C	45 \pm 0.5	85 \pm 0.5
Coolant Flow	L/min	40 \pm 2	70 \pm 2
Inlet Air Pressure	kPa	0.05 \pm 0.02	
Coolant Pressure	kPa	70 \pm 2	
Inlet Air Temperature	°C	32 \pm 0.5	
Exhaust Back Pressure	kPa	104 \pm 2	107 \pm 2
Air Charge Temperature	°C	30 \pm 0.5	
AFR	Lambda	0.78 \pm 0.05	1 \pm 0.05
Blowby outlet Temperature	°C	23 \pm 2	78 \pm 2
Humidity	g/kg	11.4 \pm 1.0	
Blowby	L/min	65 - 75	

9.2.3.1 Start the engine and let idle for 5 min then shut the engine down, these 5 min do not count toward test time. (1) Take a dip 20 min \pm 2 min after the engine shutdown.

- (2) Follow the procedure in section 9.4.1 on how to take the dip reading.

(2) Record the 0 h dip reading.

9.2.3.2 Start the engine and let idle for 5 min, these 5 min do not count toward total test time.

(1) Start the 30 min ramp to Stage 1 conditions.

(2) The test timer starts at the beginning of this ramp to Stage 1.

(3) Use the ramping conditions shown in Table 5.

9.2.4 *Cyclic Schedule, General Description:*

9.2.4.1 The test is composed of two stages as shown in Table 4 and 5.

(1) Together, the two stages and two ramps comprise one cycle. Each cycle lasts 4 h and is repeated 54 times for a total of 216 h.

(2) Six consecutive cycles are completed each 24 h period.

(3) Perform oil level measurement and sampling every 24 h.

(4) The oil level measurement and sampling procedure does not count toward test time and is described in section 9.4.1

9.2.4.2 *Test Cycle:* Each cycle is 4 h long and contains a Stage 2-1 ramp for 30 min (or start up/idle to Stage 1 at test start or after an oil dip), a Stage 1 for 120 min, a Stage 1-2 ramp for 30 min, and a Stage 2 for 60 min. This 4 h sequence is the only time that is counted as test time.

9.2.4.3 *Ramps:* The ramps between stages are 30 s (engine speed and coolant flow), 30 min (oil and coolant temperature) and 60 min (blowby temperature), to stabilize at stage conditions.

(1) The load ramps are different lengths.

(2) Ramp details are shown in Table 5.

(3) The ramps are considered complete after 30 min when the oil and coolant temperatures have reach stage conditions; at this time the stage timer starts.

(4) Note that half of the blowby temperature ramp occurs during stage operation.

(5) The coolant and oil temperature ramps ~~are linear ramps~~ between the steady state stage conditions, within ± 2 min, for the first 25 min to reach the next stage conditions.

(6) After the next stage, oil and coolant temperatures are achieved between 23 min and 27 min, with the last remaining minutes of the 30 min ramp used to stabilize at the stage conditions shown in Table 4.

(7) Figure A2.23 shows the desired shape of the ramps.

(8) The rate of speed, temperature, fuel and torque changes, as well as the amount of enrichment between stages, can influence test severity and engine component wear. Therefore, ramping rates are very important.

TABLE 5 Stages Order and Ramp Description

Stage	Description	Time (min)
Stage 1	Stage 1 conditions	120
Ramp 1 – 2 (or start up/idle to stage 2)	Linear 30 s speed and flow ramps. 3 min to 3.5 min torque ramp. Linear 30 min oil and coolant temperature ramp. 60 min blowby temperature ramp, to Stage 2 (Ramp 1-2 details below)	30
Stage 2	Stage 2 conditions	60
Ramp 2 – 1 (or start up/idle to stage 1)	Linear 30 s speed and flow ramps. 3.5 min to 4.5 min torque ramp. Linear 30 min oil and coolant temperature ramp. 60 min blowby temperature ramp, to Stage 1 (Ramp details below)	30
Stage ramp	Ramp details	

Stage 1-2 torque ramp	30 s 90 s 180 s to 240 s	95 N·m to 100 N·m 115 N·m to 120 N·m 126 N·m to 130 N·m	
Stage 2-1 torque ramp	30 s 90 s 150 s to 180 s	75 N·m to 85 N·m 55 N·m to 60 N·m 48 N·m to 52 N·m	
Stage 1-2 oil temperature ramp	Linear ramp reach 75 °C by 12.5 min ± 2 min reach 100 °C ± 0.5 °C by 25 min ± 2 min remaining time used to stabilize at 100 °C ± 0.5 °C		30
Stage 2-1 oil temperature ramp	Linear ramp reach 75 °C by 12.5 min ± 2 min reach 50 °C ± 0.5 °C by 25 min ± 2 min remaining time used to stabilize at 50 °C ± 0.5 °C		30
Stage 1-2 coolant temperature ramp	Linear ramp reach 65 °C by 12.5 min ± 2 min reach 85 °C ± 0.5 °C by 25 min ± 2 min remaining time used to stabilize at 85 °C ± 0.5 °C		30
Stage 2-1 coolant temperature ramp	Linear ramp reach 65 °C by 12.5 min ± 2 min - reach 45 °C ± 0.5 °C by 25 min ± 2 min remaining time used to stabilize at 45 °C ± 0.5 °C		0
Stage 1-2 blowby temperature ramp	Linear ramp from 23 °C to 73 °C reach 49 °C by 15 min ± 2 min reach 73 °C by 30 min ± 2 min Linear ramp from 73 °C to 78 °C, reach 78 °C ± 2 °C by 60 min (30 min of this ramp is run during Stage 2)		60
Stage 2-1 blowby temperature ramp	reach 55 °C by 15 min ± 2 min reach 32 °C by 30 min ± 2 min reach 23 °C ± 2 °C by 60 min (30 min of this ramp is run during Stage 1)		60

9.2.5 Engine Shutdown:

9.2.5.1 *Scheduled Shutdown Procedure*—Follow the procedure detailed below each time a scheduled shutdown is performed.

- (1) Scheduled shutdowns include shutdowns that occur during engine break-in and oil leveling:
- (2) Bring the engine speed to idle. Allow temperatures and flow **valves to max open other than blowby gas temperature to go free flowing** to cool the engine.
- (3) Switch the ignition off.
- (4) Turn off power to the ignition power source.

Comment [JS4]: Review blowby shutdown conditions for each lab.

- (5) Turn off fuel and coolant pumps.
- (6) Reduce the intake-air pressure to atmospheric.

9.2.5.2 *Unscheduled Engine Shutdown*—Follow the procedure detailed below, each time an unscheduled engine shutdown is performed:

- (1) Stop test timer when ramp down starts.
- (2) 30 s ramp to idle and allow all temperatures and flow valves to max open other than blowby gas temperature go free flowing to cool the engine down.
- (3) Let the engine idle for a total of 2 min, the 30 s ramp down counts as part of the 2 min. Shut the engine down after 2 min.
- (4) Switch the ignition off.
- (5) Turn off fuel and coolant pumps.
- (6) Reduce the intake-air pressure to atmospheric.

9.2.5.3 *Start-Up After Oil Leveling Period*—Follow the procedure detailed below each time an engine start-up is performed after an oil leveling period.

- (1) *Start*—5 min in idle; then ramp to Stage 1 conditions for 30 min as shown in Table 5. The 5 min of idle does not count toward the total test time.
- (2) The test timer starts at the beginning of the ramp to Stage 1 conditions.

9.2.6 *Unscheduled Downtime*—The oil leveling periods of 25 min \pm 2 min are the only scheduled shutdowns allowed during the test.

- (1) However, the test can be interrupted to perform necessary maintenance.
- (2) Note all unscheduled downtime on the Supplemental Operational Data Form of the final test report.

9.2.7 *Resumption of Test Time After Unscheduled Shutdown*—After an unscheduled shutdown, test time does not begin until the engine has reached operating conditions for the stage at which the shutdown occurred.

- (1) On start-up, idle for 5 min then use the ramp as shown in Table 5 for reaching the appropriate stage.

9.2.7.1 *Start-Up After Unscheduled Shutdown*—Follow the procedure detailed below, each time an engine start-up is performed after an unscheduled shutdown:

- (1) *Return to Stage 1*—Engine idles for 5 min then ramp to Stage 1 conditions for 30 min using the ramp as described in Table 5.
 - (1a) The total test timer and stage timer resumes from where it left off before being shut down once Stage 1 conditions are reached.
- (2) *Return to Stage 2*— Engine idles for 5 min then ramp to Stage 2 conditions for 30 min using the ramp as described in Table 5.
 - (2a) The total test timer and stage timer resumes from where it left off before being shut down once Stage 2 conditions are reached.

9.3 *Periodic Measurements and Functions:*

9.3.1 *Blowby flow rate measurement - general*

- (1) Every sixth cycle, measure and record the blowby flow rate at 30 min to 45 min into Stage 2.
 - (1a) The engine shall be stable and operating at normal Stage 2 operating conditions.
 - (2) Measure blowby when the gas temperature is at least 32 °C.
- (3) The installation of the blowby flow rate measurement apparatus is described in Fig. 9
- (4) The procedure for measuring blowby flow rate is detailed in 9.3.1.1.
- (5) Complete only one set (Stage 2) of blowby flow rate measurement during each six cycles.
- (6) Under special circumstances additional blowby flow rate measurements can be performed to determine or verify a problem with the flow rate measurement apparatus or the engine.
- (7) Record additional blowby flow rate measurements and an explanation of the reason for the additional measurements.
- (7a) Include these data in the supplemental operational data in the final test report.

9.3.1.1 *Blowby flow rate measurement - procedure*

- (1) Connect the blowby measurement device to the pressurized air source.
- (2) Open the flow valve (bleeder valve) completely.
- (3) Connect the blowby apparatus flow line to the 3-way valve located between the oil separator and intake tube.
- (4) Position the 2-way valve to divert air to the manometer from the hollow PCV valve.
- (5) Position the 2-way valve in between the PCV and throttle body to keep air from entering the throttle body.
- (6) Position the 3-way valve to divert intake manifold vacuum from the engine PCV to the exhaust plumbing of the blowby apparatus meter.

Comment [JS5]: Add J tec procedure (Christian). Task force will be formed to implement Jtec meter.

- (7) Adjust the flow valve (bleeder valve) to maintain crankcase pressure at 0 kPa to 0.025 kPa.
- (8) Record the differential pressure across the blowby meter orifice, record the blowby gas temperature, and the barometric pressure.
- (9) After completing the measurements, return the engine to normal operating configuration.
- (9a) First, reposition the 3-way valve and both 2-way valves to ensure porting of the intake vacuum to the engine PCV; then,
- (9b) disconnect the blowby apparatus hose from the closed port of the 3-way valve.
- (10) Calculate the blowby flow rate and correct the value to standard conditions (38 °C, 100.3 kPa) using the calibration data for that orifice.

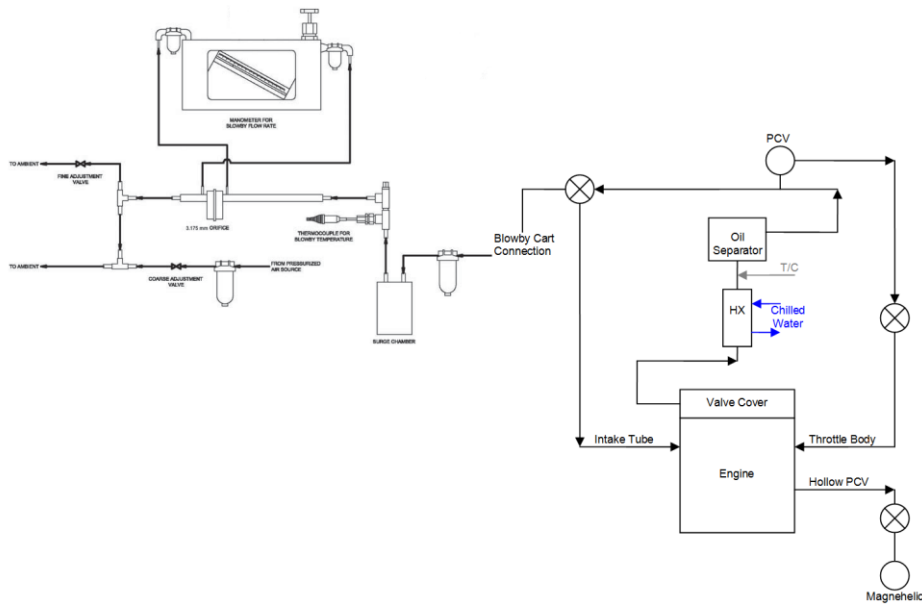

Figure 9 Blowby Cart Connection

9.3.2 Parameter Logging

9.3.2.1 Refer to Table 6 for parameter logging information.

TABLE 6 Parameter Logging

	TEST POINT	UNITS
Controlled	Engine Speed	r/min
	Engine Torque	N·m
	Coolant Out Temp	°C
	Oil Gallery Temp	°C
	Air Charge Temp	°C
	Inlet Air Temp	°C
	Inlet Air Press	kPaG
	Exhaust Back Press	kPaA
	Fuel Temp	°C
	Humidity	g/kg
Monitored	Fuel Flow	kg/hr
	Manifold Absolute Pressure (MAP)	kPaA
	Boost Pressure	kPaA
	Barometric Pressure	kPaA
	Oil Gallery Pressure	kPaG
	Oil Head Pressure	kPaG
	Oil Filter In Temp	°C
	Exhaust temp	°C
	Crank Case Pressure	kPaG
	Fuel Pressure	kPaG
	Power	kW
	Pre-Intercooler Air Pressure	kPaA
	Ambient Temperature	°C
	Coolant In Temperature	°C
	Coolant Pressure	kPaG
	Coolant Flow	L/m
	Blowby heat exchanger coolant	L/m
Lambda	unitless	
PCM CAN BUS Channels	Ignition Timing Advance for #1 Cylinder	Deg CA
	Absolute Throttle Position	%
	Engine Coolant Temperature	°C
	Inlet Air Temperature	°C
	Equivalence Ratio (Lambda)	unitless
	Absolute Load Value	%
	Intake Manifold Absolute Pressure	kPa
	Fuel Rail Pressure	kPa
	Accelerator Pedal Position	%
	Boost Absolute Pressure - Raw Value	kPa
	Turbocharger Wastegate Duty Cycle	%
	Actual Intake (A) Camshaft Position	Deg
Actual Exhaust (B) Camshaft Position	Deg	

Intake (A) Camshaft Position Actuator Duty Cycle	%
Exhaust (B) Camshaft Position Actuator Duty Cycle	%
Charge Air Cooler Temperature	° C

Table 7 PCM Parameter Logging Information

Mode	PID Number (Hex)	Parameter Description	Type	Bytes	Scale	Offset	Minimum	Maximum	Units
1	47	Absolute Throttle Position B	Unsigned Numeric	1	0.392156863	0	0	100	%
1	0E	Ignition Timing Advance for #1 Cylinder	Unsigned Numeric	1	0.5	-64	-64	63.5	Deg
1	11	Absolute Throttle Position	Unsigned Numeric	1	0.392156863	0	0	100	%
1	5	Engine Coolant Temperature	Unsigned Numeric	1	1	-40	-40	215	Deg C
1	0F	Intake Air Temperature	Unsigned Numeric	1	1	-40	-40	215	Deg C
1	34	Equivalence Ratio (Lambda)	Unsigned Numeric	2	3.0518E-05	0	0	2	Undefined / Not Used
1	43	Absolute Load Value	Unsigned Numeric	2	0.392156863	0	0	25700	%
1	0B	Intake Manifold Absolute Pressure	Unsigned Numeric	1	1	0	0	255	kPa
22	318	Actual Intake (A) Camshaft Position Bank 1	Signed Numeric	2	0.0625	0	-2048	2047.9375	Deg
22	319	Actual Exhaust (B) Camshaft Position Bank 1	Signed Numeric	2	0.0625	0	-2048	2047.9375	Deg
22	461	Charge Air Cooler Temperature Bank 1 Sensor 1 - Raw	Signed Numeric	2	0.015625	0	-512	511.984375	Deg C

Table 8 Typical Uncontrolled Parameter Ranges

Parameter	Stage 1	Stage 2
Fuel Flow, kg/h	3.2 – 3.5	8.0 – 8.5
Exhaust Temperature, °C	400 - 430	640-680

9.4 Oil Sampling:

9.4.1 *Oil level Measurement and Sampling Procedure*— Oil level measurement and sampling are scheduled at intervals of 24 h or 6 cycles.

- (1) The procedure and sample times are listed in Table 9.
- (2) The total test timer stops after every 6th cycle and Stage 2 has completed.
- (3) Perform a 30 s (speed and load) ramp to idle and let the engine idle for 4.5 min.
- (4) Remove a 120 mL to 150 mL purge sample while the engine is at idle.
- (5) Take an oil sample during these 4.5 min of idle.
- (6) Remove an oil sample from the valve attached to the T connected to the oil filter housing.
- (7) **Immediately return the purge sample to the engine.**
- (8) The location of the T where the oil is drawn is shown in Figure A9.15.

9.4.2 The minimum oil level allowed is indicated by the 100 mm mark on the calibrated oil dipstick.

- (1) Rotate the calibrated dipstick 360 degrees while still in the oil pan to measure the highest mark.
- (2) Remove the dipstick to view the mark.

TABLE 9 Oil Level Measurements and Sampling

Test Hours	24	48	72	96	120	144	168	192	216
Test Cycles	6	12	18	24	30	36	42	48	54
1	Remove a 120 mL to 150 mL purge sample while the engine is at idle.								
2	Remove a 60 mL analysis sample while the engine is at idle.								
3	Shut-down the engine 5 min after the start of oil sampling and leveling stage.								
4	Immediately return the purge sample to the engine.								
5	Record the dipstick level in millimeters 20 min \pm 2 min after the engine is shutdown.								
6	Log the oil level. The difference between the oil level and the Test Full mark is oil consumed or gained. Use the chart in Table 12 to determine the level.								
7	Restart the engine after shutdown.								

9.5 General Maintenance

- (1) The scheduled shutdown periods of 30 min during oil leveling allow limited opportunity for engine and stand maintenance.
- (2) In addition, the test can be shut down at any convenient time to perform unscheduled maintenance; however, minimize the duration of a shutdown. Report any unscheduled shutdown on the Supplemental Operational Data Sheet.

9.6 Special Maintenance Procedures

- (1) Functions that require special maintenance procedures are listed in this section.
- (2) These maintenance procedures are specifically detailed because of the effect on test validity or because they require special care while being completed.
- (3) Check the oil level before performing any maintenance requiring removal of the front cover or rear seal housing.
 - (3a) If the level is above 130 mm, the oil level is above the oil pan rail and a portion of the oil must be removed from the oil drain plug before performing the maintenance to ensure oil doesn't leak over the pan rail.
- (4) Use a clean container to catch the oil removed from the pan.
- (5) Before restarting the test, return the oil to the engine after the maintenance is completed.

9.7 Blowby Flow Rate Adjustment—A blowby adjustment can only be done within the first 24 h of the test.

- (1) Blowby measurement taken during the first test Stage 2 after break in (3.25 h to 3.45 h) provides a good indication how the blowby will perform for the rest of the test.
- (2) If that blowby value is less than 70 L/min, a blowby adjustment **may** be made to achieve at least 70 L/min flow.
- (3) Adjust the blowby by changing the ring gaps or replacing piston rings, if necessary.
- (4) Ring gaps shown in Table 11 typically produce the above blowby levels. However, these can be adjusted as necessary to achieve the correct blowby level.
- (5) Use the ring cutting procedure outlined in 8.18.2
- (6) Stage 2 blowby **average** for the test during the first 120 h of the test must fall within the range from 65 L/min to 75 L/min as listed in Table 10. The Stage 2 times are also listed in Table 10.

TABLE 10, 2nd Stage Blowby Readings

Stage 2 Blowby Readings		
Test Hours	Blowby Reading	Use these boxes for AVG.
3.5-3.75		
23.5-23.75		70 L/min Recommended
47.5-47.75		

71.5-71.75		
95.5-95.75		
119.5-119.75		
143.5-143.75		23.5 h to 119.75 h Blowby average must be between 65 L/min to 75 L/min.
167.5-167.75		
191.5-191.75		
215.5-215.75		
Test Average		

TABLE 11, Suggested Piston Ring Gaps

Top piston ring gap	1.651 mm (0.065 in.)
2nd piston ring gap	1.778 mm (0.070 in.)

9.7.1 *High Blowby Flow Rate Adjustment*—Reduce high blowby flow rate by replacing the compression rings with new rings that have smaller ring gaps. **Ensure that the ring gap stagger remains at .127 mm (0.005 in.)**

9.7.2 *Low Blowby Flow Rate Adjustment*—Increase low blowby flow rate by increasing the ring gaps of the compression rings. **Measure ring gaps to determine existing ring gaps and ring gap stagger. Maintain the same ring gap stagger.**

9.7.3 *Engine Disassembly and Reassembly for Maintenance (Before End of Test)*:

9.7.3.1 Engine assembly and disassembly shall adhere to the procedures in 8.9 and 9.7.4.2, respectively

- (1) When the engine is disassembled for maintenance, drain as much test oil as possible from the oil pan into a clean container, and retain that oil for installation in the engine after reassembly.
- (2) Take precautions to ensure the oil is not contaminated and to ensure that deposits are not disturbed on any parts.
- (3) All parts should be placed in or over clean drain pans to collect oil that drains off while maintenance is being performed.
- (4) The timing chain should be placed in a separate container to prevent it from getting contaminated.

9.7.3.2 During reassembly, used drained test oil may be utilized to lubricate the engine parts.

- (1) Do not use EF-411 oil or new test oil during engine reassembly.
- (2) After the engine has been reassembled, reinstall the used test oil removed from the oil pan and collected from the engine parts during disassembly and maintenance.
- (2a) Do not add any new test oil to the pan.

10. Diagnostic Data Review

10.1 This sub-section outlines significant characteristics of specific engine operating parameters. The following PCM parameters can directly influence the test or can be used to indicate normalcy of other parameters.

10.1.1 Engine Torque

- (1) Engine torque is controlled in Stage 1 and 2 . It should remain relatively constant throughout a test and from test-to-test.
- (2) Large differences in torque reading could be indicative of control or engine problems.

10.1.2 Fuel Consumption Rate

- (1) The fuel consumption rate should remain relatively constant throughout the test. Fuel consumption rate is not a specifically controlled parameter but is used as a diagnostics tool.

10.1.3 Exhaust Gas Component Levels

- (1) Use the Lambda levels in the exhaust gas to determine the characteristics of combustion that occur during the test.
- (2) Use this parameter to determine the normalcy of combustion and any significant changes in combustion that occur throughout a particular test.

(3) Lambda in all two stages is controlled by the program in the Powertrain Control Module. No adjustments can be made to change the exhaust gas Lambda.

(3a) If Lambda differs from what appears in **Table 4**, check the PCM and test cell control system. Correcting a fault in the PCM and test cell control system is the only way to achieve the correct Lambda value.

10.1.4 Crankcase Pressure

(1) Crankcase pressure is a function of blowby flow rate and PCV valve flow.

(2) High crankcase pressure is usually caused by high blowby flow rate or a significant loss of PCV valve flow. (3) Incorrect three-way valve plumbing or port plugging also promotes high crankcase pressure.

(4) Low or negative crankcase pressure might be caused by low blowby flow rate or a restriction of vent air to the PCV valve.

10.1.5 Oil Pressure

(1) The oil pressure is a function of oil viscosity and operating temperature. The oil pressure should remain consistent throughout the test, unless the oil exhibits a significant change in viscosity.

10.1.6 Oil Temperature Differential

(1) The oil temperature differential is primarily a function of oil flow rate and oil viscosity and is normally stable throughout the test.

(2) The differential can change if the oil viscosity changes significantly during the test.

10.1.7 *Coolant Temperature Differential*—The coolant temperature differential is primarily a function of the coolant flow rate and is normally stable throughout the test.

(1) Large variations in the differential can be caused by coolant flow rate or temperature measurement errors.

10.2 End of Test Procedures

10.2.1 Final Drain

(1) Drain the engine coolant after the completion of the last test cycle.

(2) Engine oil can be drained with the engine in or out of the engine stand.

10.2.2 Engine Disassembly

(1) During disassembly, ensure the original location of the parts can be identified with respect to either the cylinder number, valve location, bearings, etc.

10.2.3 Parts Layout for Measurement

(1) Lightly wipe down the timing chain of any excess oil and make sure to keep the chain free of any contaminants or debris.

(2) Prepare the timing chain for end of test measurement as listed in the *Timing Chain Measurement and Cleaning Procedure*.

11. Test Results

11.1 Primary test result

11.1.1 Calculate and record the change in timing chain length from Hour 0 to the end of test:

Chain elongation = 2 X (final average measurement-initial average measurement)/nominal chain length. The nominal chain length is 1095.375 mm (43.125 in.)

11.2 Used oil analyses

11.2.1. Testing Oil Samples for Element Concentration-Use Inductively Coupled Plasma Atomic Emission Spectrometry (ICP-AES) Analysis, Test Method D5185, to determine the mass fraction of the following 15 elements: aluminum, boron, calcium, chromium, copper, iron, lead, manganese, molybdenum, potassium, phosphorus, silicon, sodium, tin and zinc. Report in mg/kg

11.2.2. Testing Oil Samples for Pentane Insolubles using test method DXXXX. Report in percent.

11.2.3. Testing Oil Samples for water content by Karl Fischer using test method D6304. Report in percent.

11.2.4. Testing Oil Samples for Total Base Number using test methods D4739. Report in gKOH/g.

11.2.5. Testing Oil Samples for Total Acid Number using test methods D664. Report in gKOH/g.

11.2.6. Testing Oil Samples for viscosity at 40°C and 100°C using test method D445. Report in mm²/s

11.2.7. Testing Oil Samples for soot content by TGA using test method D5967, Annex A4. Report in percent.

11.2.8 Conduct the above analysis for the fresh oil, each of the 24 h oil samples and the EOT sample. Report the results on Form 6.

12. Report

- 12.1 For reference oil results, use the standardized report form set available from the ASTM TMC and data dictionary for reporting test results and for summarizing operational data.

NOTE 10—Report the non-reference oil test results on these same forms if the results are intended to be submitted as candidate oil results against a specification.

- 12.1.1 Fill out the report forms according to the formats shown in the data dictionary.
 12.1.2 Transmit results to the TMC within 5 working days of test completion.
 12.1.3 Transmit the results electronically as described in the ASTM Data Communications Committee Test Report Transmission Model (Section 2 — Flat File Transmission Format) available from the ASTM TMC. Upload files via the TMC's website.
 12.2 Report all reference oil test results, whether aborted, invalidated, or successfully completed, to the TMC.
 12.3 *Deviations from Test Operational Limits*—Report all deviations from specified test operational limits.
 12.4 *Precision of Reported Units*—Use the Practice E29 rounding-off method for critical pass/fail test result data.
 (1) Report the data to the same precision as indicated in data dictionary.
 12.5 In the space provided, note the time, date, test hour, and duration of any shutdown or off-test condition.
 (1) Document the outcome of all prior reference oil tests from the current calibration sequence that were operationally or statistically invalid.
 12.6 If a calibration period is extended beyond the normal calibration period length, make a note in the comment section and attach a written confirmation of the granted extension from the TMC to the test report.
 (1) List the outcomes of previous runs that may need to be considered as part of the extension in the comment section.

13. Precision and Bias

13.1 Test Precision—Reference Oils:

13.1.1 *Intermediate Precision Conditions*—Conditions where test results are obtained with the same test method using the same test oil, with changing conditions such as operators, measuring equipment, test stands, test engines, and time.

Note 11—“Intermediate precision” is the appropriate term for this test method rather than “repeatability,” which defines more rigorous within-laboratory conditions.

13.1.1.1 *Intermediate Precision Limit (i.p.)*—The difference between two results obtained under intermediate precision conditions that would, in the long run, in the normal and correct conduct of the test method, exceed the values shown in Table 8 in only one case in twenty.

Table 8 Test Precision^A

	Intermediate Precision		Reproducibility	
Test Result	0.14148	0.39215 ^B	0.17856	0.49493 ^B

Change in timing chain length (mm)

^A These statistics are based on results obtained on Test Monitoring Center Reference Oils over the period from through

^B This value is obtained by multiplying the standard deviation by 2.8.

13.1.2 *Reproducibility Conditions*—Conditions where test results are obtained with the same test method using the same test oil in different laboratories with different operators using different equipment.

13.1.2.1 *Reproducibility Limit (R)*—The difference between two results obtained under reproducibility conditions that

would, in the long run, in the normal and correct conduct of the test method, exceed the values in Table 8 in only one case in twenty.

13.2 *Bias*—Bias will be determined by applying an accepted statistical technique to reference oil test results, and when a significant bias is determined, a severity adjustment will be permitted for non-reference oil test results.

14. Keywords

14.1 timing chain; engine oil; turbocharger, ramp, blowby

ANNEXES (Mandatory Information)

A1. ASTM TEST MONITORING CENTER ORGANIZATION

A1.1 *Nature and Functions of the ASTM Test Monitoring Center (TMC)*—The TMC is a non-profit organization located in Pittsburgh, Pennsylvania and is staffed to: administer engineering studies; conduct laboratory inspections; perform statistical analyses of reference oil test data; blend, store, and ship reference oils; and provide the associated administrative functions to maintain the referencing calibration program for various lubricant tests as directed by ASTM Subcommittee D02.B0 and the ASTM Executive Committee. The TMC coordinates its activities with the test sponsors, the test developers, the surveillance panels, and the testing laboratories. Contact TMC through the TMC Director at:

ASTM Test Monitoring Center
6555 Penn Avenue
Pittsburgh, PA 15206-4489
www.astmtmc.cmu.edu

A1.2 *Rules of Operation of the ASTM TMC*—The TMC operates in accordance with the ASTM Charter, the ASTM Bylaws, the Regulations Governing ASTM Technical Committees, the Bylaws Governing ASTM Committee D02, and the Rules and Regulations Governing the ASTM Test Monitoring System.

A1.3 *Management of the ASTM TMC*—The management of the Test Monitoring System is vested in the Executive Committee elected by Subcommittee D02.B0. The Executive Committee selects the TMC Director who is responsible for directing the activities of the TMC.

A1.4 *Operating Income of the ASTM TMC*—The TMC operating income is obtained from fees levied on the reference oils supplied and on the calibration tests conducted. Fee schedules are established by the Executive Committee and reviewed by Subcommittee D02.B0.

A2. ASTM TEST MONITORING CENTER: CALIBRATION PROCEDURES

A2.1 *Reference Oils*—These oils are formulated or selected to represent specific chemical, or performance levels, or both. They are usually supplied directly to a testing laboratory under code numbers to ensure that the laboratory is not influenced by prior knowledge of acceptable results in assessing test results. The TMC determines the specific reference oil the laboratory shall test.

A2.1.1 *Reference Oil Data Reporting* – Test laboratories that receive reference oils for stand calibration shall submit data to the TMC on every sample of reference oil they receive. If a shipment contains any missing or damaged samples, the laboratory shall notify the TMC immediately.

A2.2 *Calibration Testing:*

A2.2.1 Full-scale calibration testing shall be conducted at regular intervals. These full-scale tests are conducted using coded reference oils supplied by the TMC. It is a laboratory's responsibility to keep the on-site reference oil inventory at or above the minimum level specified by the TMC test engineers.

A2.2.2 *Test Stands Used for Non-Standard Tests*—If a non-standard test is conducted on a previously calibrated test stand, the laboratory shall conduct a reference oil test on that stand to demonstrate that it continues to be calibrated, prior to running standard tests.

A2.3 *Reference Oil Storage*—Store reference oils under cover in locations where the ambient temperature is between -10 °C and +50 °C.

A2.4 *Analysis of Reference Oil*—Unless specifically authorized by the TMC, do not analyze TMC reference oils, either physically

or chemically. Do not resell ASTM reference oils or supply them to other laboratories without the approval of the TMC. The reference oils are supplied only for the intended purpose of obtaining calibration under the ASTM Test Monitoring System. Any unauthorized use is strictly forbidden. The testing laboratory tacitly agrees to use the TMC reference oils exclusively in accordance with the TMC's published Policies for Use and Analysis of ASTM Reference Oils, and to run and report the reference oil test results according to TMC guidelines. Additional policies for the use and analysis of ASTM Reference Oils are available from the TMC.

A2.5 Conducting a Reference Oil Test—When laboratory personnel are ready to run a reference calibration test, they shall request an oil code via the TMC website.

A2.6 Reporting Reference Oil Test Results—Upon completion of the reference oil test, the test laboratory transmits the data electronically to the TMC, as described in Section ?. The TMC reviews the data and contacts the laboratory engineer to report the laboratory's calibration status. All reference oil test results, whether aborted, invalidated, or successfully completed, shall be reported to the TMC.

A2.6.1 All deviations from the specified test method shall be reported.

A3. ASTM TEST MONITORING CENTER: MAINTENANCE ACTIVITIES

A3.1 Special Reference Oil Tests—To ensure continuous severity and precision monitoring, calibration tests are conducted periodically throughout the year. Occasionally, the majority or even all of the industry's test stands will conduct calibration tests at roughly the same time. This could result in an unacceptably large time frame when very few calibration tests are conducted. The TMC can shorten or extend calibration periods as needed to provide a consistent flow of reference oil test data. Adjustments to calibration periods are made such that laboratories incur no net loss or gain in calibration status.

A3.2 Special Use of the Reference Oil Calibration System—The surveillance panel has the option to use the reference oil system to evaluate changes that have potential impact on test severity and precision. This option is only taken when a program of donated tests is not feasible. The surveillance panel and the TMC shall develop a detailed plan for the test program. This plan requires all reference oil tests in the program to be completed as close to the same time as possible, so that no laboratory/stand calibration status is left pending for an excessive length of time. In order to maintain the integrity of the reference oil monitoring system, each reference oil test is conducted so as to be interpretable for stand calibration. To facilitate the required test scheduling, the surveillance panel may direct the TMC to lengthen and shorten reference oil calibration periods within laboratories such that the laboratories incur no net loss or gain in calibration status. To ensure accurate stand, or laboratory, or both severity assessments, conduct non-reference oil tests the same as reference oil tests.

A3.3 Donated Reference Oil Test Programs—The surveillance panel is charged with maintaining effective reference oil test severity and precision monitoring. During times of new parts introductions, new or re-blended reference oil additions, and procedural revisions, it may be necessary to evaluate the possible effects on severity and precision levels. The surveillance panel may choose to conduct a program of donated reference oil tests in those laboratories participating in the monitoring system, in order to quantify the effect of a particular change on severity and precision. Typically, the surveillance panel requests its panel members to volunteer enough reference oil test results to create a robust data set. Broad laboratory participation is needed to provide a representative sampling of the industry. To ensure the quality of the data obtained, donated tests are conducted on calibrated test stands. The surveillance panel shall arrange an appropriate number of donated tests and ensure completion of the test program in a timely manner.

A3.4 Intervals Between Reference Oil Tests—Under special circumstances, such as extended downtime caused by industry-wide parts or fuel shortages, the TMC may extend the intervals between reference oil tests.

A3.5 Introducing New Reference Oils—Reference oils produce various results. When new reference oils are selected, participating laboratories will be requested to conduct their share of tests to enable the TMC to recommend industry test targets. ASTM surveillance panels require a minimum number of tests to establish the industry test targets for new reference oils.

A3.6 TMC Information Letters—Occasionally it is necessary to revise the test method, and notify the test laboratories of the change, prior to consideration of the revision by Subcommittee D02.B0. In such a case, the TMC issues an Information Letter. Information Letters are balloted semi-annually by Subcommittee D02.B0, and subsequently by D02. By this means, the Society due process procedures are applied to these Information Letters.

A3.6.1 Issuing Authority—The authority to issue an Information Letter differs according to its nature. In the case of an Information Letter concerning a part number change which does not affect test results, the TMC is authorized to issue such a letter. Long-term studies by the surveillance panel to improve the test procedure through improved operation and hardware control may result in the issuance of an Information Letter. If obvious procedural items affecting test results need immediate attention, the test sponsor and the TMC issue an Information Letter and present the background and data supporting that action to the surveillance panel for approval prior to the semiannual Subcommittee D02.B0 meeting.

A3.7 TMC Memoranda—In addition to the Information Letters, supplementary memoranda are issued. These are developed by the TMC and distributed to the appropriate surveillance panel and participating laboratories. They convey such information as batch

approvals for test parts or materials, clarification of the test procedure, notes and suggestions of the collection and analysis of special data that the TMC may request, or for any other pertinent matters having no direct effect on the test performance, results, or precision and bias.

A4. ASTM TEST MONITORING CENTER: RELATED INFORMATION

A4.1 *New Laboratories*—Laboratories wishing to become part of the ASTM Test Monitoring System will be requested to conduct reference oil tests to ensure that the laboratory is using the proper testing techniques. Information concerning fees, laboratory inspection, reagents, testing practices, appropriate committee membership, and rater training can be obtained by contacting the TMC Director.

A4.2 *Information Letters: COTCO Approval*—Authority for the issuance of Information Letters was given by the committee on Technical Committee Operations in 1984, as follows: “COTCO recognizes that D02 has a unique and complex situation. The use of Information Letters is approved providing each letter contains a disclaimer to the effect that such has not obtained ASTM consensus. These Information Letters should be moved to such consensus as rapidly as possible.”

A4.3 *Precision Data*—The TMC determines the precision of test methods by analyzing results of calibration tests conducted on reference oils. Precision data are updated regularly. Current precision data can be obtained from the TMC.

A5. ENGINE AND STAND PARTS

A5.1 Tables A5.1 – A5.6 list the engine and stand part numbers

Table A5.1 Assembled Test Engine

ENGINE ASSEMBLY		
Current Ford Service Part Number	Current Ford Engineering Part Number	Description
BB5Z-6006-A	BB5E-6006-AD DA8E-6006-BB	2.0L ENGINE ASY LB
Table A5.2 Reusable Engine Parts		
Current Ford Service Part Number	Current Ford Engineering Part Number	Description
1S7Z6507B	1S7G6507D7G	VALVE - INLET
1S7Z6514AA	1S7G6514AE	RETAINER - VALVE SPRING
1S7Z6518AA	1S7G6518AD	KEY, VALVE SPRG
1S7Z8501A	1S7G8501BD	PUMP ASY - WATER
8W9Z6C287A	AG9E6C287AA	TAPPET ASY, FU PMP
AG9Z6010B	AG9E6010A34B	CYLINDER BLOCK
AG9Z6135B	AG9E6135AA	PIN - PISTON
AG9Z6140A	AG9G6140BA	RETAINER - PISTON PIN
AG9Z6200D	AG9E6200CD	ROD - CONNECTING
AG9Z6250A	AG9E6A268AB	CAMSHAFT, LH (EXHAUST)
AG9Z6303A	BB5E6300A33A	CRANKSHAFT ASY
AG9Z6505A	AG9E6505AA	VALVE - EXHAUST
AG9Z6600B	AG9E6600AB	PUMP ASY - OIL
AG9Z6A785A	AG9G6A785CA	SEPARATOR ASY - OIL
AG9Z9350B	AG9E9D376AB	PUMP ASY - FUEL
AG9Z9P847A	AG9G9P847AA	BRACKET, FU INJ CLIP
BB5Z2A451C	BB5E2A451BD	PUMP ASY - VACUUM
BB5Z6019C	BB5E6019AF	COVER - CYLINDER FRONT
BB5Z6250A	BB5E6A267AB	CAMSHAFT, RH (INTAKE)

Comment [JS6]: Review part numbers and update -Ron

Comment [JS7]: Add all variant part numbers

BB5Z6881A	BB5E6881AD	ADPT OIL FILTER
BB5Z6K269A	DB5E6K269AA	COUPLING - PUMP DRIVE
BB5Z9F593B	BB5E9F593BA	INJECTOR ASY
CJ5Z6049C	CJ5E6C032AC	CYLINDER HEAD ASY
CJ5Z6513A	CJ5E6513AA	SPRING - VALVE
CJ5Z6582A	CJ5E6K271BG	COVER - CYLINDER HEAD
CJ5Z6K254A	CJ5E6C271AA	TENSIONER, OIL PUMP DRIVE
CJ5Z6M280A	CJ5E6B297AA	SOLENOID - ENGINE VARIABLE TIMING
CJ5Z9D280A	CJ5E9D280BF	MANIFOLD ASY - FUEL SUPPLY
CJ5Z9D440A	CJ5E9B374BC	COVER - FUEL PUMP
CM5Z6652A	CM5E6652AA	GEAR, OIL PUMP DRIVE
CM5Z6A895A	CM5E6A895AA	CHAIN ASY - OIL PUMP DRIVE
CYFS12Y2	CB5E12405AA	SPARK PLUG
AG9Z-6108-H	AG9E-6110-AC2	PISTON- STD

Table A5.3 Fasteners

Current Ford Service Part Number	Current Ford Engineering Part Number	Description
F5TZ6A785A	F57E6A785AC	SEPARATOR ASY - OIL, EXT
W500033S437	W500033S437	BOLT - FLANGED HEX.
W500114S442	W500114S442	BOLT
W500212S437	W500212S437	SCREW
W500214S437	W500214S437	BOLT - HEX.HEAD
W500221S437	W500221S437	BOLT - HEX.HEAD
W500224S437	W500224S437	BOLT
W500300S437	W500300S437	BOLT
W500301S437	W500301S437	BOLT
W500310S437	W500310S437	BOLT - HEX.HEAD
W500313S437	W500313S437	BOLT
W500328S437	W500328S437	BOLT
W500414S442	W500414S442	BOLT
W503275S437	W503275S437	BOLT - HEX. HEAD - FLANGED
W505531S442	W505531S442	SCREW
W506976S442	W506976S442	SCREW
W520214S440	W520214S440	NUT
W700115S437	W700115S437	SCREW AND WASHER ASY
W701183S300	W701183S300	DOWEL - BUSH
W701219S437	W701219S437	BOLT
W702426S303	W702426S303	BOLT - HEX.HEAD
W702492S437	W702492S437	STUD

W702700S437	W702700S437	STUD
W703383S437	W703383S437	BOLT
W703643S430	W703643S430	BOLT
W703649S300	W703649S300	PIN
W704474S437	W704474S437	STUD
W706282S430	W706282S430	BOLT
W706284S437	W706284S437	BOLT
W706487S437	W706487S437	BOLT-OIL COOLER FILTER
W711261S437	W711261S437	BOLT
W711574S439	W711574S439	STUD
W712022S430A	W712022S430	BOLT - HEX.HEAD
W713095S403	W713095S403	NUT
W715323S300	W715323S300	WASHER - COPPER, T/C OIL LINE
W715638S443	W715638S443	STUD
W715848S437	W715848S437	BOLT
W716137S437	W716137S437	BOLT
W716735S437	W716735S437	BOLT
W716841S900	W716841S900	PIN, BELL HOUSING
1L5Z6379AA	W706161S300	BOLT
1S7Z6A340AA	1S7G6K340BC	BOLT, CRK SHFT PULLEY
1S7Z6K282AA	1S7G6K282AB	BOLT, CHAIN TEN
AG9Z6065A	AG9G6065BA	BOLT - HEX.HEAD, CYL HEAD
AG9Z6345A	AG9G6345AC	BOLT - BEARING CAP - HEX. HEAD
BB5Z6214A	BB5E6214CA	BOLT - CONNECTING ROD
CV6Z6279A	CV6E6279AA	BOLT, CAMSHAFT

Table A5.4 Test Parts List

Current Ford Service Part Number	Current Ford Engineering Part Number	Description
1S7Z6378AA	1S7G6378AB	WASHER,CRK DIAMOND CRUSH
AG9Z-6148-A	AG9E-6148-AA	KIT-PISTON RING
6M8Z6278A	6M8G6278AA	WASHER, CAM, DIAMOND CRUSH
7T4Z9601A	7T439601AA	ELEMENT ASY - AIR CLEANER
CJ5Z6256B	CJ5E6C524AD	SPROCKET - CAMSHAFT, LH
CJ5Z6268A	CJ5E6268AA	BELT/CHAIN - TIMING
CJ5Z6306A	CJ5E6306AB	GEAR - CRANKSHAFT
CJ5Z6C525A	CJ5E6C525AD	SPROCKET - CAMSHAFT, RH
CJ5Z6K254B	CJ5E6K254AA	TENSIONER - TIMING

		CHAIN
CJ5Z6K255A	CJ5E6K255AB	ARM - TIMING CHAIN TENSIONER
CJ5Z6K297A	CJ5E6K297AB	GUIDE, TIMING CHAIN

Table A5.5 Gaskets List

Current Ford Service Part Number	Current Ford Engineering Part Number	Description
CJ5Z6079D	CJ5E6079AC	KIT - GASKET
1S7Z6571EA	1S7G6A517BG	SEAL - VALVE STEM EX
1S7Z6840AA	1S7G6A636AD	GASKET, OIL FILTER ADPT
1S7Z6B752AA	1S7G6B752AC	GASKET, OIL SEP
1S7Z6K301BA	1S7G6A321AA	SEAL - CRANKSHAFT REAR OIL
1S7Z8507AE	1S7G8507AF	GASKET - WATER PUMP
3M4Z6625AA	3M4G6625AA	GASKET, OIL PMP P/U TUBE
3M4Z8255A	3M4G8K530AB	GASKET, T/STAT HSG
3S4Z6571AA	3S4G6A517AA	SEAL - VALVE STEM INT
9L8Z9E936A	9L8E9E936AA	GASKET, T/B
AA5Z9E583A	AA5E9E583AA	SEAL, FU PUMP
AG9Z9P431A	AG9G9P431AA	GASKET, T/C COOL LINE
BB5Z2A572B	BB5E2D224BB	GASKET - VACUUM PUMP
BB5Z6584A	BB5E6K260AB	GASKET, CAM COVER
BB5Z6L612A	BB536L612AA	GASKET, EXHAUST
BG9Z9229A	BG9E9U509AB	KIT - "O" RING, FU INJ
BR3Z6C535B	BR3E6P251BA	SEAL - VALVE VCT
CB5Z9276A	CJ5E9A420BA	GASKET, FU PUMP CVR
CJ5Z6051A	CJ5E6051EC	GASKET - CYLINDER HEAD
CJ5Z6N652A	CJ5E6N652AA	GASKET, T/C OIL DRAIN LINE
CJ5Z8255A	CJ5E8255AA	SEAL - THERMOSTAT
CJ5Z9439A	CJ5E9439AA	GASKET - INTAKE MANIFOLD
CJ5Z9448A	CJ5E9448BA	GASKET, EX MANIFOLD
CM5Z6700A	CM5E6700AB	SEAL ASY - CRKSHAFT OIL - FRT

Table A5.6 Test Stand Set Up Parts List

Current Ford Service Part Number	Current Ford Engineering Part Number	Description
AG9Z9D930B	AG9T9H589BE	WIRE ASY, FE INJ
1S7Z12A699BB	1S7A12A699BB	SENSOR - ENGINE KNOCK
6M8Z6C315AA	6M8G6C315AB	SENSOR - CRANKSHAFT POSITION - CPS
8F9Z9F472A	8F9A9Y460AB	SENSOR ASY, MAF

8V2Z12B579A	8V2112B579AA	SENSOR ASY
9L8Z6G004E	9L8A6G004BC	SENSOR ASY, CYL HD TMP
AA5Z9A600B	AA539A600AD	CLEANER ASY - AIR
AE5Z6A228A	AE5Q6A228AA	PULLEY ASY - TENSION BELT
AE5Z8620A	AE5Q6C301AA	V-BELT
AG9Z6K679A	AG9G6K679BC	PIPE - OIL FEED, T/C
AG9Z6K868A	CJ5E6K868AA	VALVE ASY, ENG PST OIL COOL
AG9Z6L092A	AG9G6K677BC	HOSE - T/C OIL DRAIN
AG9Z8555A	AG9G8A506BB	HOSE - WATER INLET, T/C
AG9Z9F479A	AG919F479AB	SENSOR ASY, MAP
AS7Z6B288A	AS7112K073AA	SENSOR - CAMSHAFT POSITION
BB3Z6A642A	BB3E6A810AA	KIT ENGINE OIL COOLER
BB5Z11002C	BB5T11000AA	STARTER MOTOR ASY
BB5Z5A231A	BB535A281AA	CLAMP - HOSE, T/C TO EXH
BB5Z6C640A	BB536K863CE	CONNECTION - AIR INLET T/B END
BB5Z6C640B	BB536K863DF	CONNECTION - AIR INLET, I/C END
BB5Z6C646C	BB536C646CD	DUCT - AIR, TURBO END
BB5Z6C646D	BB536C646DF	DUCT - AIR, INTERCOOLER END
BB5Z6C683A	BB5E6L663AA	FILTER ASY (T/C SCREEN)
BB5Z9647A	BB539647AB	BRACKET, AIRBOX
BB5Z9661A	BB539643AA	COVER, AIRBOX
BB5Z9B659B	BB539F805DE	HOSE - AIR, TURBO END
BB5Z9B659E	BB539F805CG	HOSE - AIR, AIR BOX END
BM5Z9F972A	BM5G9F972BA	SENSOR - FUEL INJECTOR PRESSURE
BR2Z9E499A	BR2E9E499AA	CONNECTOR, VAC CONTRL, T/C
CB5Z6K682F	CB5E6K682BF	TURBO CHARGER
CB5Z8592A	CB5E8592AB	CONNECTION - WATER OUT, T/C
CB5Z8K153B	CB5E8B535AC	TUBE - WATER OUTLET
CB5Z9424D	CB5E9424AF	MANIFOLD ASY - INTAKE
CB5Z9S468C	CB5E9S468AF	HOSE, EMS (VAC HARNESS)
CJ5Z9J323B	CJ5E9J323BC	TUBE ASY FE PMP TO FE MAN
CM5Z12029A	CM5E12A366CA	COIL ASY - IGNITION
CP9Z9E926A	CM5E9F991AD	THROTTLE BODY AND MOTOR ASY
D4ZZ7600A	D4ZA7120AB	SLEEVE, PILOT BEARING
DU5Z12A581U	DU5T12C508UE	WIRE ASY, ENGINE MAIN
YS4Z6766A	YS4G6766DA	CAP ASY - OIL FILLER
5M6Z8509AE	5M6Q8509AE	PULLEY - WATER PUMP
AG9Z6312B	AG9E6D334AA	PULLEY - CRANKSHAFT

Table A5.7 Special Parts List	
OHT PART NUMBER	DESCRIPTION
OHTVH-002-1	PAN, OIL MODIFIED, ASSY. (INCLUDING DIPSTICK AND PICK UP TUBE)
VH002-2	TUBE, PICK UP
OHTVH-005-1	HOUSING, FLYWHEEL
OHTVH-006-1	FLYWHEEL, MODIFIED, 2.0L
VH006-8	CLUTCH, ASSY. W/ PRESSURE PLATE
VH006-8-1	CLUTCH
VH006-8-2	PLATE, PRESSURE
OHTVH-007-1	HARNESS, DYNO, 2.0L
OHTVH-008-1	INLET, COOLANT
VH008-1	CLIP, RETAINER, SENSOR, COOLANT INLET
VH008-2	SEAL, COOLANT INLET
OHTVH-009-1	OUTLET, COOLANT
VH009-6	SEAL, COOLANT OUTLET
OHTVH-011-1	SHIM, CLUTCH PRESSURE PLATE
M-6026-23BSBP	CFM Ford Racing Balance Shaft Delete Kit
MSI-41/55S-22	MSI Driveshaft

Table A5.8 - Service Tools

Camshaft alignment tool	Ford P/N 303-1565
Crankshaft TDC timing peg	Ford P/N 303-507
Crankshaft sensor alignment tool	Ford P/N 303-1521

CHAIN MEASUREMENT RIG PARTS (Table A5.9)

Description	Quantity	Manufacturer	Mfg PN	suggested Supplier	Supplier PN
PUSH PIN FOR END CAP	6	80/20	3274		
PC DATA INPUT DEVICE	1	MITUTOYO	264-012-10	CLEVELAND SPECIALTY INSPECTION SERVICES,	264-012-10

				INC.	
SPC CABLE	1	MITUTOYO	905338	CLEVELAND SPECIALTY INSPECTION SERVICES, INC. MSC	905338
MITUTOYO ELECTRONIC DIAL INDICATOR	1	MITUTOYO	543-792	MSC	60777216
CLAMP	1	DESTACO	609-B	MSC	90968736
BEARING, FOR GEARS	2	NICE	3016DCTN TG18	FASTENAL	4194269
PILLOW BLOCK BEARING, SPB12	4	THOMPSON	SPB12	GRAINGER	2HXW8
SHAFTS 24 IN	2	THOMPSON	QS 3/4 L 24	GRAINGER	5JW62
T-NUT, SLIDE-IN, OFFSET, 80/20 3278	69	80/20	3278		
BRACKET, 4-HOLE, CORNER, 80/20, 4301	14	80/20	4301		
BRACKET, 2-HOLE, CORNER, 80/20, 4302	4	80/20	4302		
END CAP, 1515 LITE, 80/20, 2030	6	80/20	2030		
CRANKSHAFT GEAR, MODIFIED	2	FORD	CJ5Z-6306- A	MARSHALL FORD MCMaster	CJ5Z-6306- A 58605K35
NEODYMIUM DISC MAGNET, 1/4" DIAMETER, 1/4" THICK, 2.5 LBS. MAXIMUM PULL	4			MCMaster	5862K95
NEODYMIUM DISC MAGNET, 3/8" DIAMETER, 1/8" THICK, 3 LBS. MAXIMUM PULL	1			MCMaster	65985K14
MAGNETIC SWITCH	2			MCMaster	9540K756
ROUND BUMPER, RUBBER, 1-1/2" DIAMETER, 5/16" DIAMETER HOLE, WITH WASHER	4			MCMaster	
PARKER MPE SERIES 60 MM FRAME 2 STACK SERVO MOTOR WITH 2500 LINE ENCODER	1	PARKER	MPE0602A 4E-KC1N	PARKER	MPE0602A4 E-KC1N
PARKER ARIES 750 WATT SERVO DRIVE WITH CONTROLLER (REQUIRES PROGRAMMING)	1	PARKER	AR-08CE	PARKER	AR-08CE
PARKER MPE TO ARIES 25 FOOT POWER CABLE	1	PARKER	71-030630- 25	PARKER	71-030630- 25
PARKER MPE TO ARIES 25 FOOT FEEDBACK CABLE	1	PARKER	71-030631- 25	PARKER	71-030631- 25
3.5MM AUDIO CABLE	1				

A6. SAFETY PRECAUTIONS

A6.1 The operating of engine tests can expose personnel and facilities to safety hazards. Personnel trained and experienced with engine testing should perform the design, installation, and operation of test stands.

A6.2 Install guards (shields) around all external moving, hot, or cold components. Design the guard to contain the energy level of a rotating component should the component break free. Fuel, oil, coolant, and electrical wiring should be properly routed, guarded, grounded and kept in good order.

A6.3 Keep the test stand free of oil and fuel spills and tripping hazards. Do not permit containers of oil or fuel, or both, to accumulate in the testing area. Firefighting equipment should be immediately accessible. Observe normal precautions whenever using flammable solvents for cleaning purposes.

A6.4 Safety masks, glasses, or hearing protection, or a combination thereof, should be worn by personnel working on the test stand. No loose or flowing clothing, including long hair or other accessory to dress, should be worn near rotating equipment. Caution personnel against working alongside the engine and driveline while the engine is running.

A6.5 Interlocks should automatically shut down the engine when an anomaly in any of the following occur: engine or dynamometer coolant temperature, engine oil pressure, dynamometer field current, engine speed, exhaust temperature, excessive vibration, or when the fire protection system is activated. The interlock should include a method to cut off the fuel supply to the engine at the injector pump (including the return line). A remote fuel cut off station (external to the test stand) is recommended.

A6.6 Employ other safety precautions as required.

A7. ENGINE REBUILD TEMPLATES

A7.1 Piston ring setter

Fig. A7.1: Piston Ring Setter

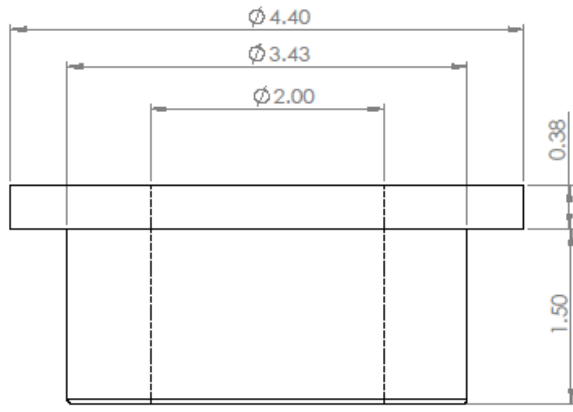

PROPRIETARY AND CONFIDENTIAL
 THE INFORMATION CONTAINED IN THIS DRAWING IS THE SOLE PROPERTY OF <ESBET COMPANY NAME HERE>. ANY REPRODUCTION IN PART OR AS A WHOLE WITHOUT THE WRITTEN PERMISSION OF <ESBET COMPANY NAME HERE> IS PROHIBITED.

		DIMENSIONS ARE IN INCHES		NAME	DATE
		TOLERANCES:		DRAWN	
		FRACTIONALS		CHECKED	
		ANGULAR: MACH ±		ENG APPR.	
		TWO PLACE DECIMAL ±		MFG APPR.	
		THREE PLACE DECIMAL ±			
		MATERIAL		Q.A.	
		AL 6061		COMMENTS:	
NEXT ASSY	USED ON	FINISH		Handle not included .	
APPLICATION		DO NOT SCALE DRAWING		SIZE	DWG. NO.
				A	
				SCALE: 1:2	WEGHE
					REV. 1
					SHEET 1 OF 1

CW Piston Ring Setter

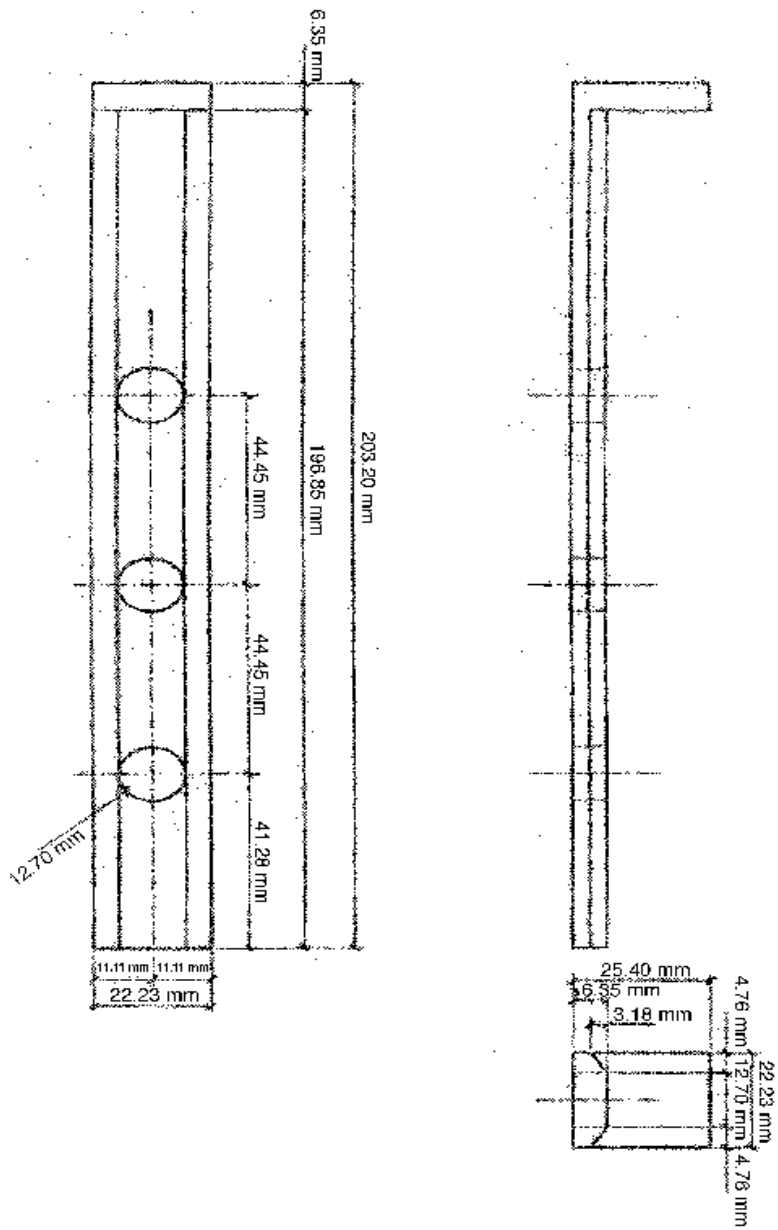

Fig. A7.2: Cylinder Bore Ladder

A8. ENGINE BUILD RECORDS

A8.1 Cylinder head build (Fig. A8.1.)

CW Head Build Data Sheet

Head #: _____

Engine #: _____

Head Run #: _____

Tests#: _____

Date: _____

	Valve Guide Diameter (mm)	Valve Stem Diameter (mm)	Clearance (mm)
1A Intake			
1B Intake			
2A Intake			
2B Intake			
3A Intake			
3B Intake			
4A Intake			
4B Intake			

	Valve Guide Diameter (mm)	Valve Stem Diameter (mm)	Clearance (mm)
1A Exhaust			
1B Exhaust			
2A Exhaust			
2B Exhaust			
3A Exhaust			
3B Exhaust			
4A Exhaust			
4B Exhaust			

	Spring Free Length (mm)	Spring Tension @28.7mm
1A Intake		
1B Intake		
2A Intake		
2B Intake		
3A Intake		
3B Intake		
4A Intake		
4B Intake		

	Spring Free Length (mm)	Spring Tension @28.7mm
1A Exhaust		
1B Exhaust		
2A Exhaust		
2B Exhaust		
3A Exhaust		
3B Exhaust		
4A Exhaust		
4B Exhaust		

Intake Valve Lash Measurement	
(mm)	
1F	
1R	
2F	
2R	
3F	
3R	
4F	
4R	

Exhaust Valve Lash Measurement	
(mm)	
1F	
1R	
2F	
2R	
3F	
3R	
4F	
4R	

Head Flatness: _____

Mechanic Initials: _____

Figure A8.1: Cylinder Head Build Record

A8.2 Cylinder bore measurement (see Fig. A8.2)

CW Cylinder Bore Measurement Record

Block #: _____

Test # _____

Block Run #: _____

Date: _____

Cylinder Bore Measurements

Finish Target (RA):
Bore Gauge Set: XXX mm

Out of Round (limit): 0.0XXmm
Taper (limit): 0.0XX mm

Cylinder Number	Location	Longitudinal Diameter (mm)	Transverse Diameter (mm)	Surface Finish (µmm)
	Top			
1	Middle			
	Bottom			
	Top			
2	Middle			
	Bottom			
	Top			
3	Middle			
	Bottom			
	Top			
4	Middle			
	Bottom			

Cylinder Number	Top Ring Gap (mm)	Second Ring Gap (mm)
1		
2		
3		
4		

REGAP/EDT

Cylinder Number (mm)	Top Ring Gap (mm)	Second Ring Gap (mm)
1		
2		
3		
4		

Approved _____

Block Flatness: _____

Mechanic Initials: _____

Fig. A8.2: Cylinder Bore Measurement Record

A8.3 Bearing Journals Measurement (Fig. A8.3)

CW Engine Measurement Record

Engine Number: _____ **Date:** _____

Test Number: _____ **Technician:** _____

Main Bearing Journals (mm)

Journal Number	Horizontal Diameter	Vertical Diameter	Bearing Inside Diameter	Clearance
1				
2				
3				
4				
5				

Rod Bearing Journals (mm)

Journal Number	Horizontal Diameter	Vertical Diameter	Bearing Inside Diameter	Clearance
1				
2				
3				
4				

Crankshaft End Play (mm) _____

Figure A8.3: Bearing Journals Measurement Record

A9. Engine Part Photographs, Schematics, and Figures

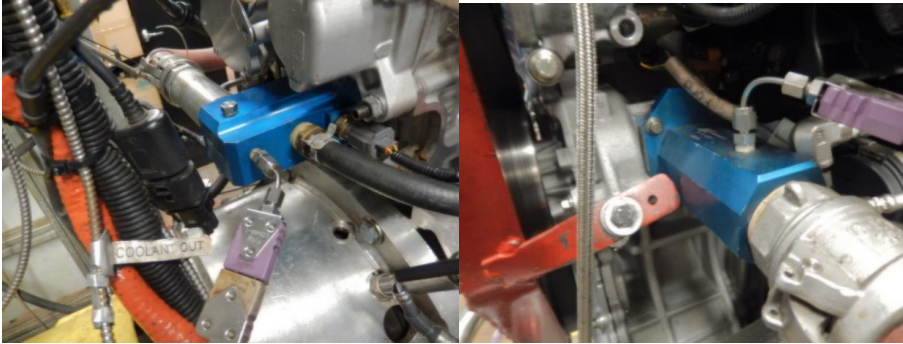

Coolant out

Coolant in

Coolant in and out connections and thermocouple locations

FIG. A9.1

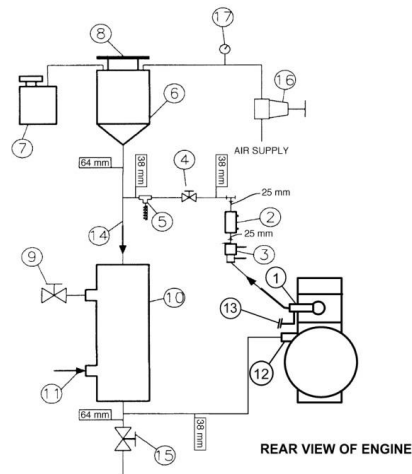

NOTE 1—Observe temperature sensor locations in thermostat housing and at water pump inlet.

NOTE 2—Components of Engine Cooling System—

- (1) **Thermostat housing, coolant out with temperature sensor (OHTVH-009-1)**
- (2) Sight glass
- (3) Flowmeter
- (4) Flow control valve
- (5) Optional temperature sensor
- (6) Fabricated coolant reservoir
- (7) Constant full expansion tank
- (8) Pressure radiator cap (MOTORCRAFT RS40 P/N D2YY-8100-A)
- (9) Process water control valve (regulated by temperature controller with three remote set points)
- (10) Heat exchanger (ITT Standard P/N 5-030-06-048-001 TYP.)
- (11) Process water supply (shell side)
- (12) **Water pump inlet with temperature sensor (OHTVH-008-1)**
- (13) **Turbocharger coolant return**
- (14) Engine coolant (tube side)
- (15) Coolant system drain valve
- (16) Coolant pressure regulator
- (17) Coolant pressure gage

FIG. A9.2 Typical Engine Cooling System Schematic

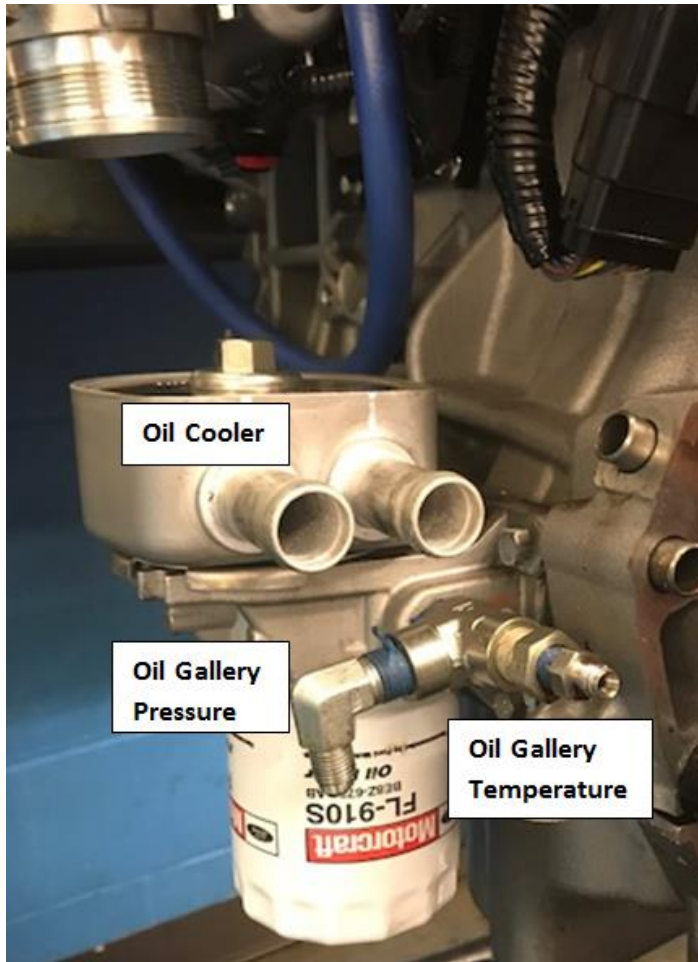
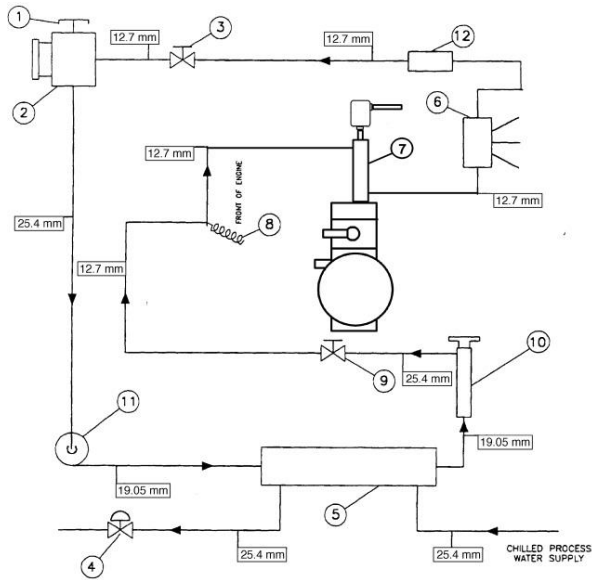

Fig.A 9.3 Oil cooler showing temp measurement locations



Fig.A 9.3 Oil cooler showing temp measurement locations



Legend

- (1) Vented reservoir cap
- (2) Coolant reservoir (fabricated)
- (3) Pressure control valve (optional)
- (4) Chilled process water control valve
- (5) System heat exchanger
- (6) F and P Co. flowrator tube, FF-1-35-G-10/448D053U06
- (7) CCV Heat Exchanger
- (8) Inlet temperature sensor
- (9) Flow control valve
- (10) External heat source
- (11) Electric coolant pump DAYTON 6K581A
- (12) ABB Kent-Taylor flow element, 1330LZ08000-8375A

FIG. A9.3 Typical CCV Heat Exchanger Heating and Cooling System



Figure A9.3 Motor mounts, front

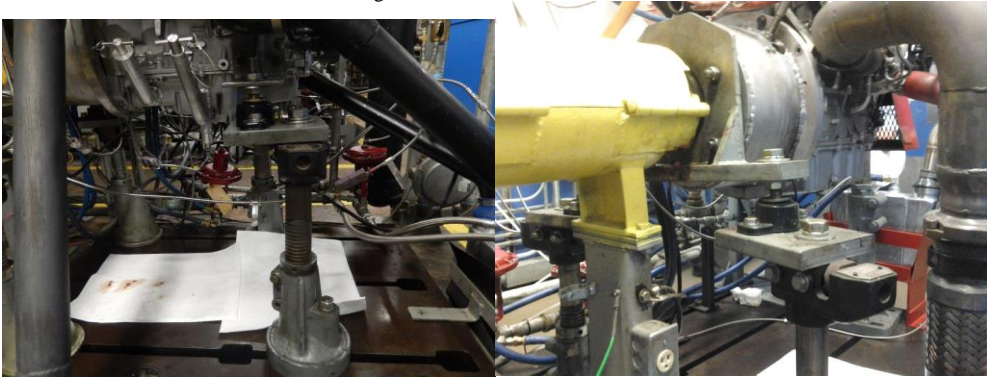

Figure A9.4 Motor mounts, rear

Figure A9.5 Front Mount Bracket

Figure A9.6 Front Mount Bracket

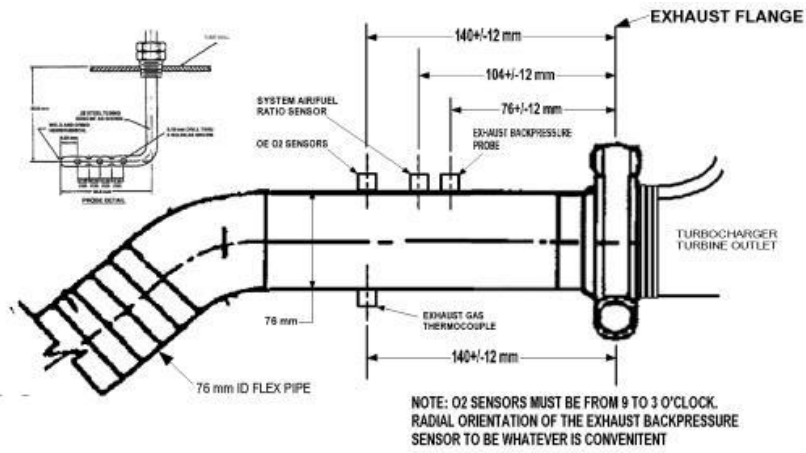

Figure A9.8: Exhaust Measurements and Instrumentation

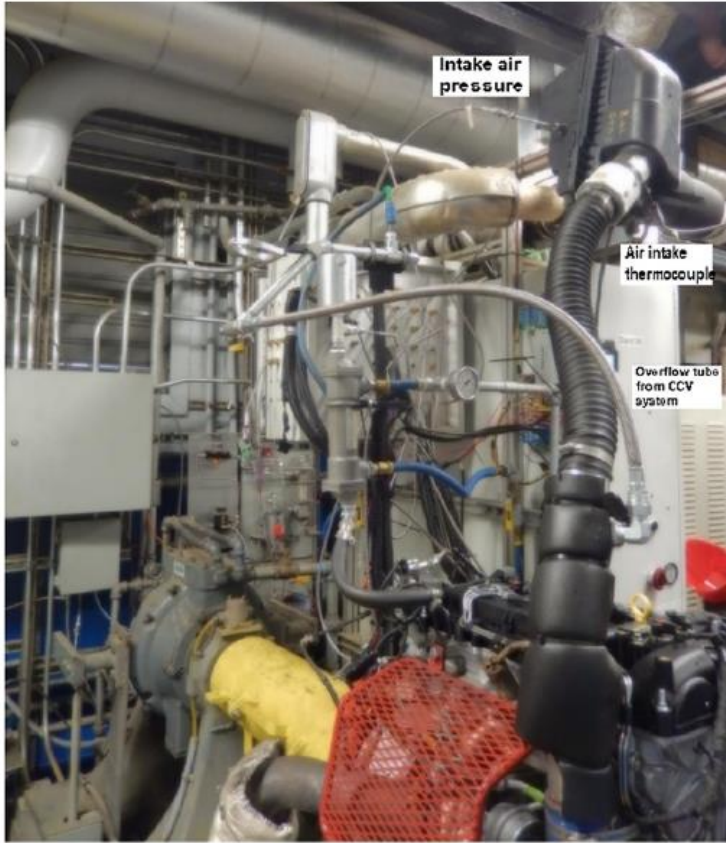

FIG. A9.12 Typical air intake system

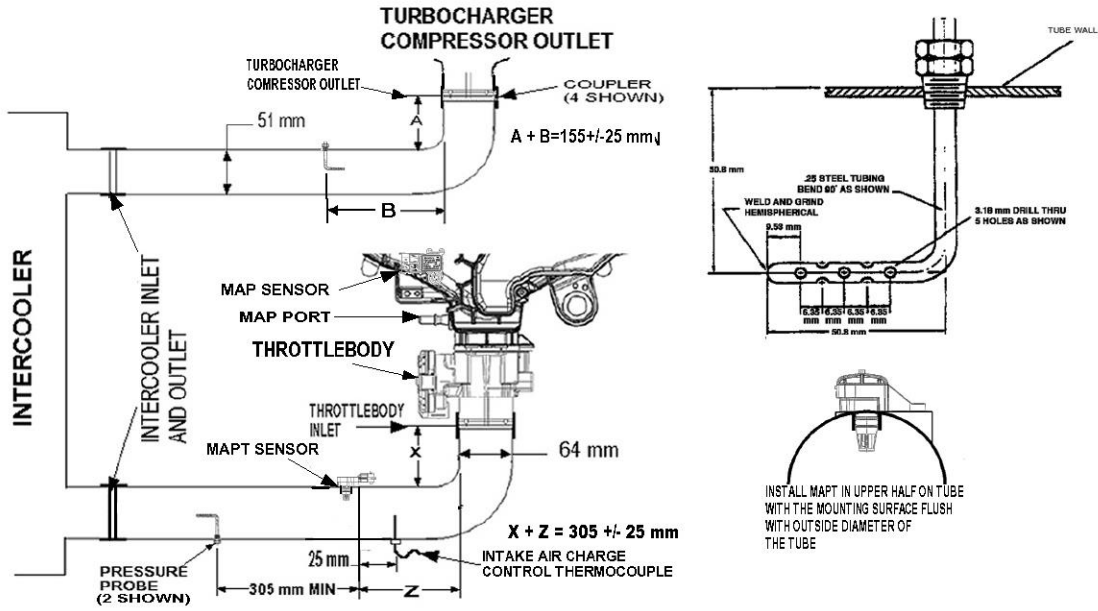

Figure A9.13: Intercooler Tubing Measurements and Instrumentation

Figure A9.14 Typical intercooler installation

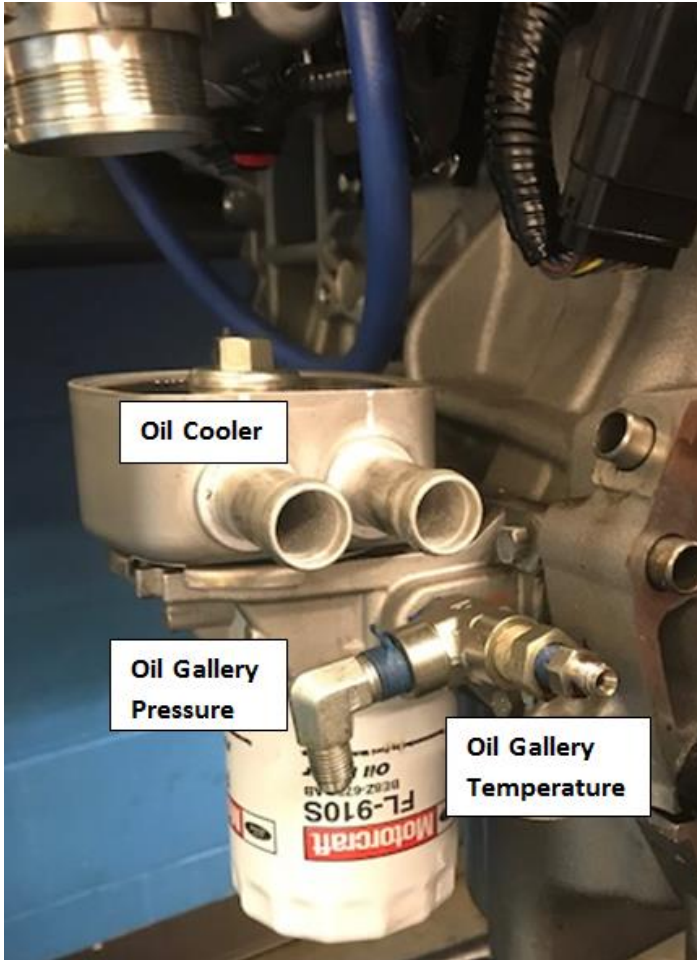
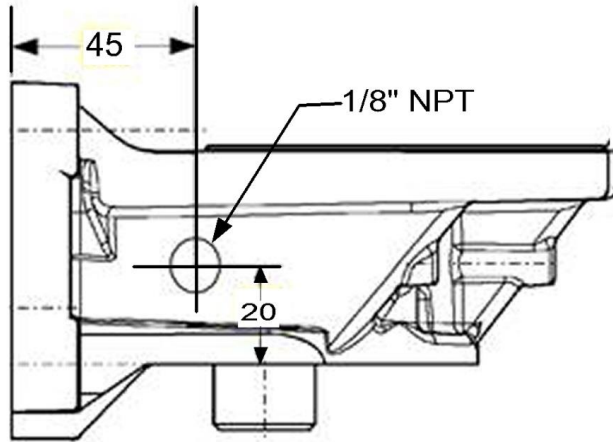

Figure A9.15 Oil cooler showing oil gallery pressure location (Duplicate of A2.15)

Figure A9.16 Oil cooler showing oil temperature locations (Duplicates)



Oil Out temperature location in oil filter adapter (Dimensions in mm)
 Figure A2.16 Oil cooler showing oil temperature locations

Figure A9.17

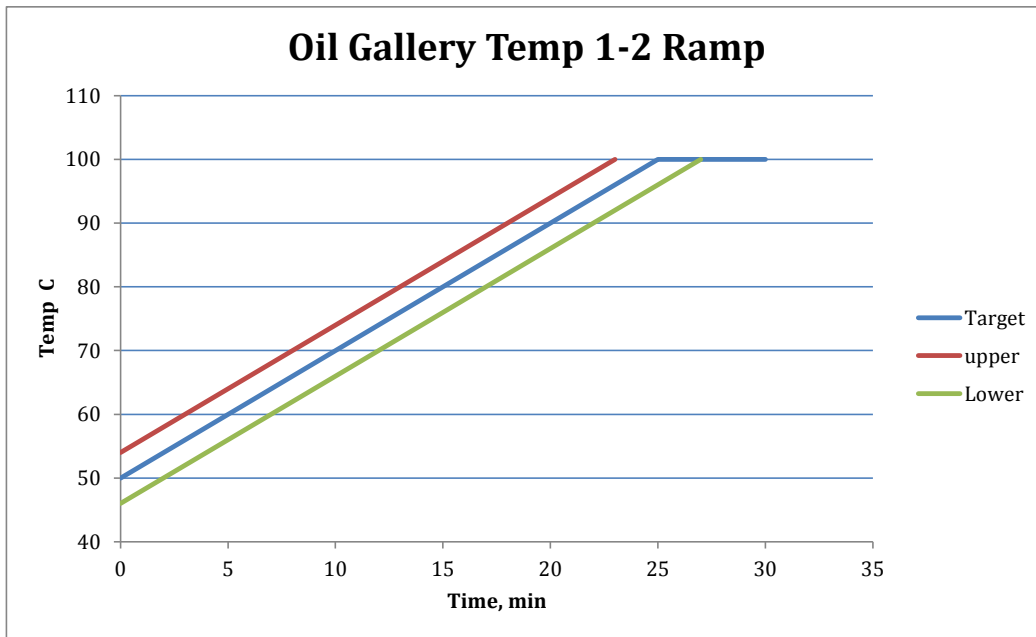

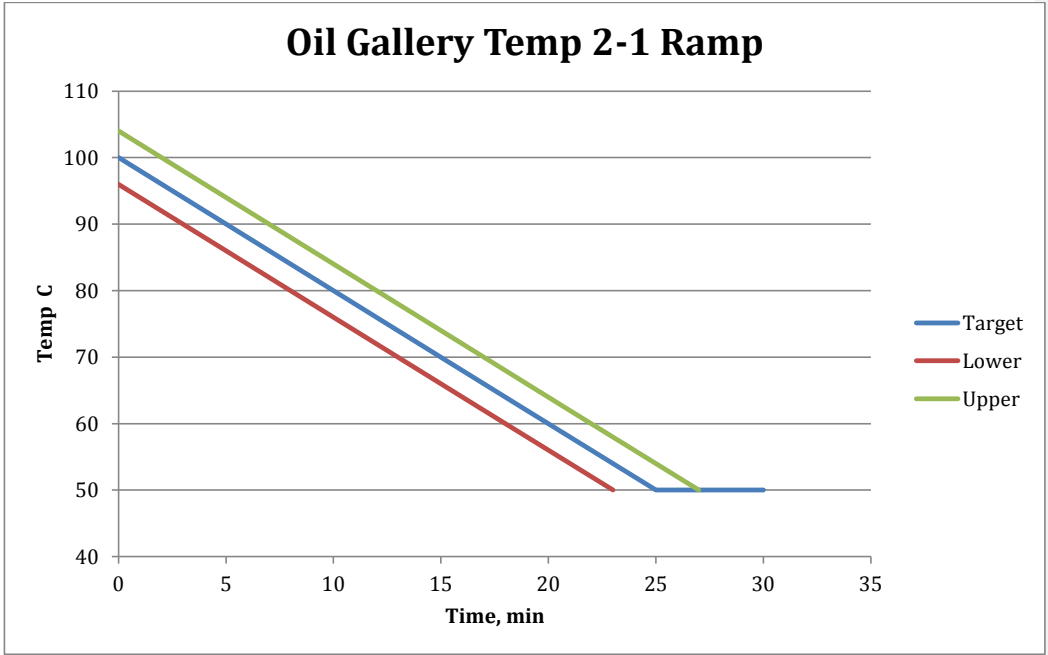

Typical Torque and temperature ramps
Figure A9.23

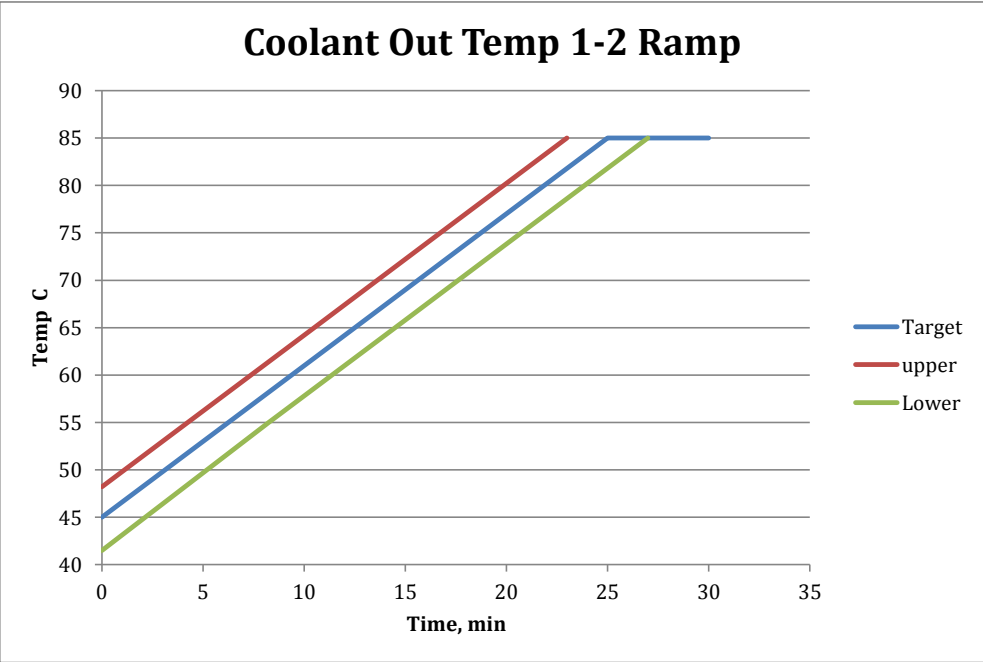
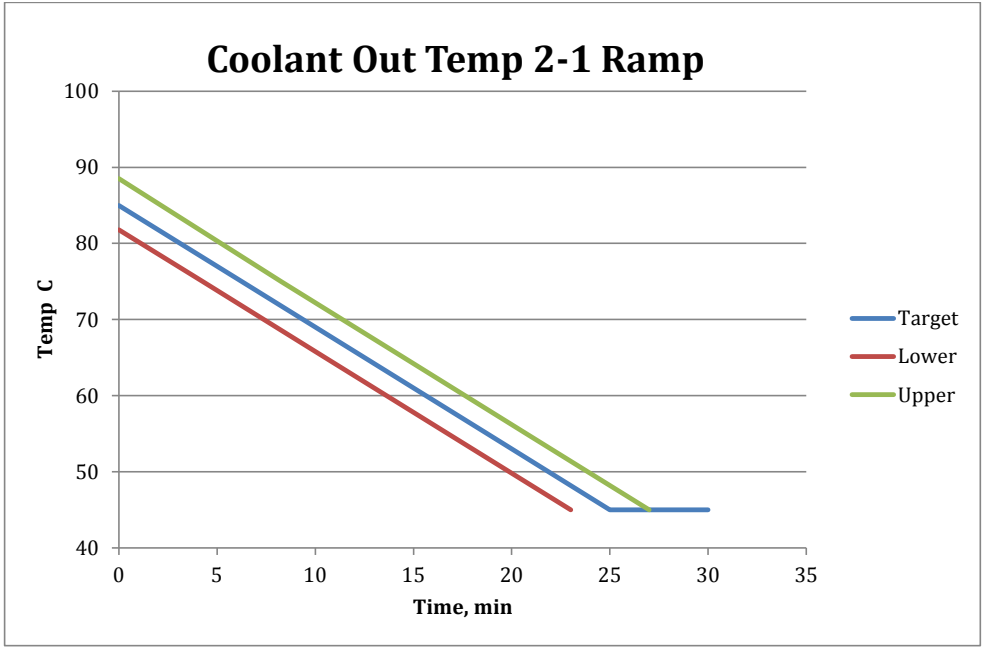

Typical Torque and temperature ramps
Figure A9.23 (cont)

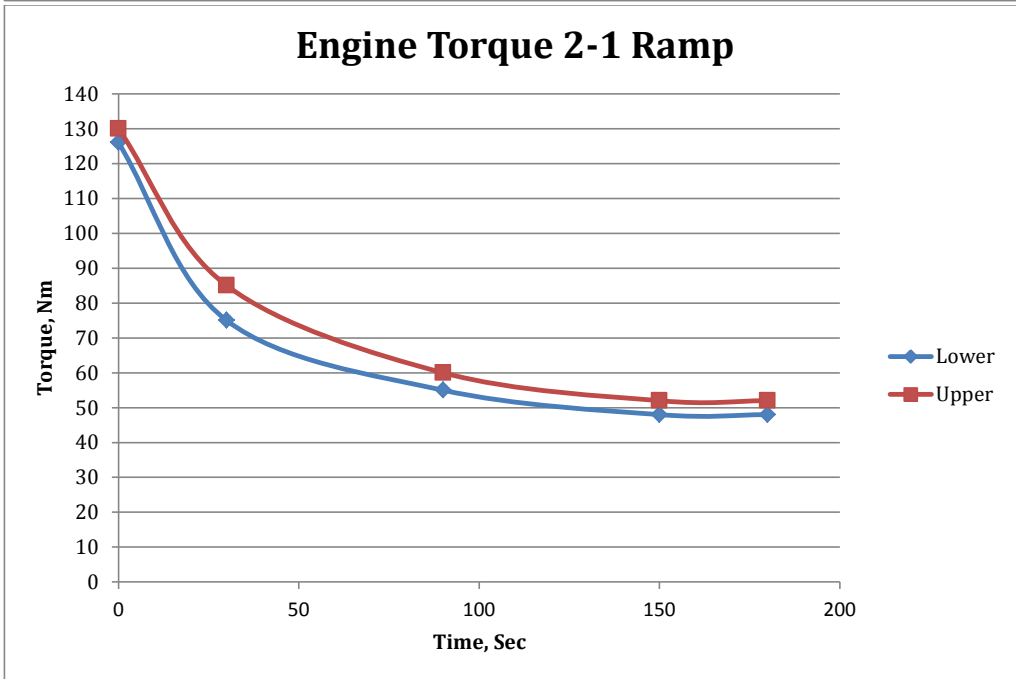
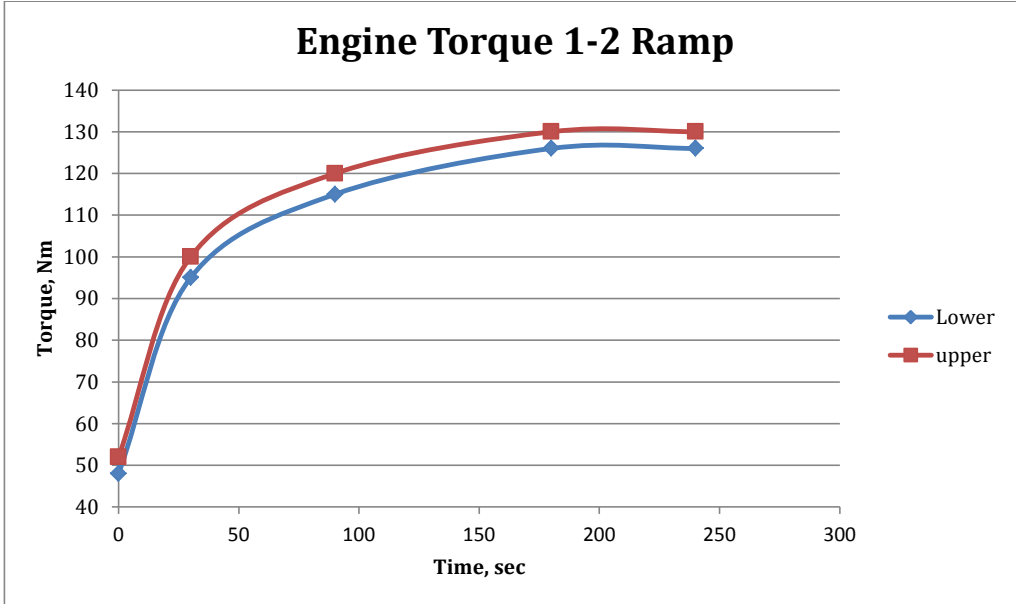

Typical Torque and temperature ramps
Figure A9.23 (cont)

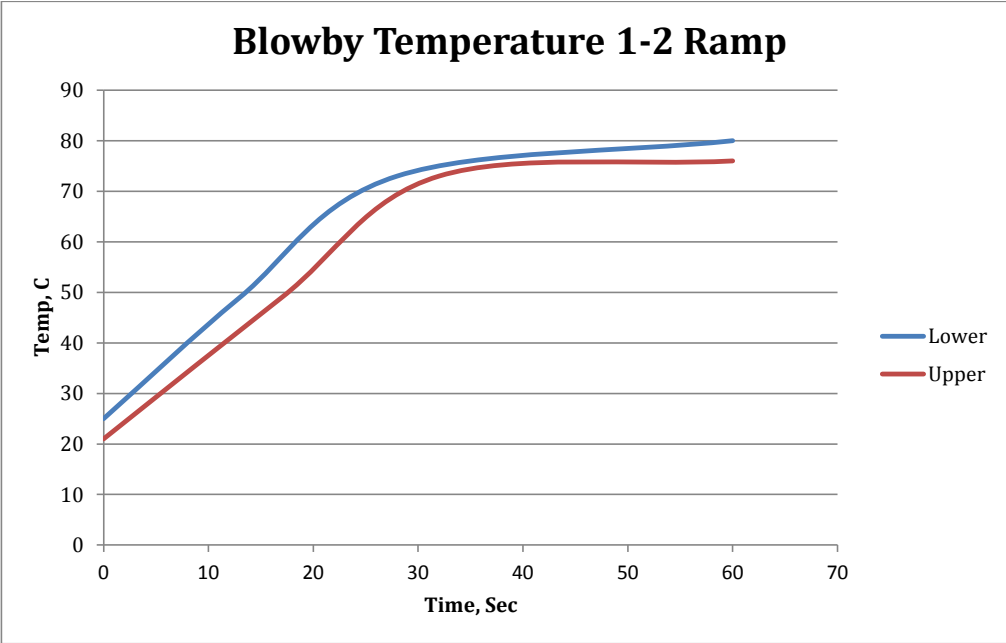
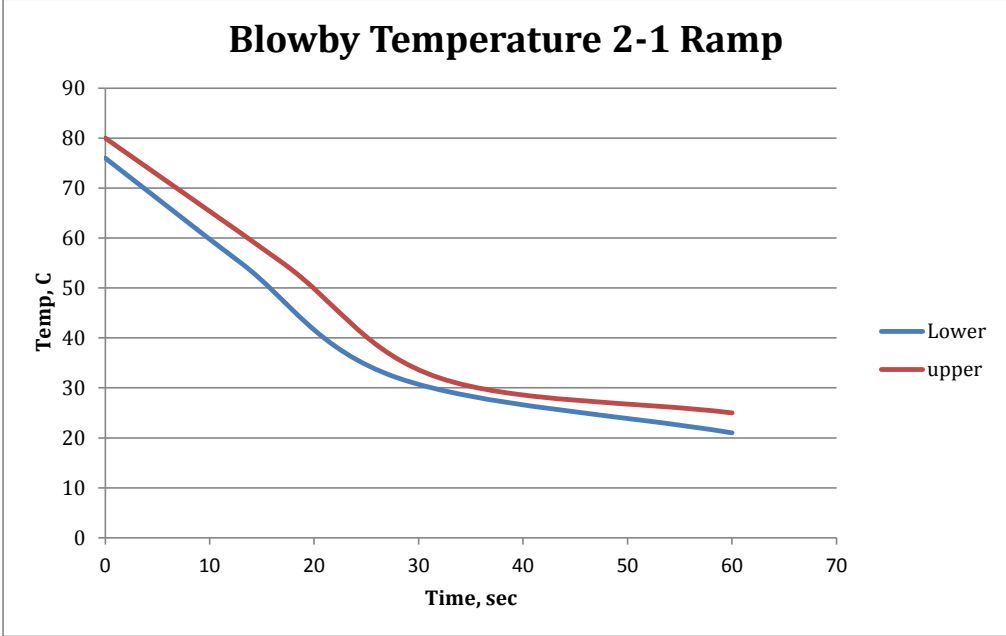

Typical Torque and temperature ramps
Figure A9.23 (cont)

A10. CONTROL AND DATA ACQUISITION REQUIREMENTS

A10.1 General Description:

A10.1.1 The data acquisition system shall be capable of logging the operational data in digital format. It is to the advantage of the laboratory that the system be capable of real time plotting of controlled parameters to help assess test validity. The systems shall be capable of calculating real time quality index as this will be monitored throughout the test as designated in A2.5.

A10.1.2 Control capability is not dictated by this procedure. The control system shall be capable of keeping the controlled parameters within the limits specified in Table 4 (see 12.2.3) and maintain the quality index shown in A2.5.

A10.1.3 Design the control and data acquisition system to meet the requirements listed below. Use the recommendations laid out in the Instrumentation Task Force Report and Data Acquisition Task Force Report for any items not addressed in Annex A2.

A10.2 *Digital Recording Frequency*—The maximum allowable time period over which data can be accumulated is one second. This data can be filtered, as described in A2.6, and will be considered a reading.

A10.3 Steady State Operation:

A10.3.1 This portion of the test will be the entire time at Stage 1 and 2 conditions. Stage 1 and 2 conditions are reached by the end of the ramping periods. Calculate the quality index using values reported to the accuracy levels in Table A2.1.

TABLE A10.1 Accuracy Levels of Data Points to be Used in QI Calculations

Parameter	Field Length
Speed	5.0
Humidity	5.1
Temperature, Coolant Out, Oil Gallery, Blowby Outlet	7.2
Torque	5.1
Intake Air Pressure	7.2
Exhaust Backpressure	6.3
Coolant Outlet Pressure	6.1
Coolant Flow	6.1
Lambda	5.2

5.1

TABLE A10.2 L and U Constants and Over and Under-Range Values

Parameter	Stages	L	U	Over-Range	Under-Range
Coolflow	1	38	42	267	0
	2	68	72	267	0
Cooloutt	1	84.5	85.5	134	0
	2	45.5	44.5	134	0
Exhbprs	1	102	106	304	0
	2	105	109	304	0
Humidity	1, 2	10.4	12.4	109.9	0
Intairpr	1, 2	0.03	0.07	2	13.9
Intairt	1, 2	31.5	32.5	81.2	0
Oilint	1	99.5	100.5	149.2	0.8
	2	49.5	50.5	149.2	0.8
Speed	1	2505	2495	2992	1058
	3	1555	1545	2992	1058
Torque	1	48	52	325	0
	2	128	132	325	0
Cooloutp	1, 2	68	72	267	0

Airchrgt	1.2	29.5	30.5	79.2	0
Lambda	1	0.73	0.83	5.9	0
	2	0.95	1.05	5.9	0

TABLE A10.3 Maximum Allowable Time Constants

Control Parameter	Time Constant, s
Engine speed, r/min	0.5
Torque, Nm	0.7
Engine oil in, °C	0.6
Engine coolant out, °C	0.6
Engine coolant flow, L/min	8.0
Blowby in, °C	0.6
Intake, air, °C	0.6
Intake air press, kPa	0.2
Exhaust back pressure, kPa	0.2
Engine coolant pressure	2.0

A10.3.2 The time intervals between recorded readings shall not exceed 1 min. Data shall be recorded throughout the length of each stage.

A10.4 *Transitions* :

A10.4.1 The ramp requirements are listed in 12.2.3.3, Table 5.

A10.4.2 During the transition, the time intervals between all recorded readings shall not exceed 2 seconds..

A10.5 *Quality Index*:

TBD

A10.6 *Time Constants*:

A10.6.1 Filtering can be applied to all control parameters. The amount of filtering applied shall not allow time constants to exceed the values listed in [Table A2.3](#). This time constant shall pertain to the entire system, running from the sensor to the display and data acquisition.

A10.6.2 Maximum allowable system time constants for the controlled parameters are shown in [Table A3.3](#)

APPENDIXES

(Nonmandatory Information)

X1. SOURCES OF MATERIALS AND INFORMATION

X1.1 For convenience, some sources for materials and information are listed below:

X1.2 Test Engine Parts -

Ford Component Sales, Ford Motor Co., 290 Town Center Dr, Dearborn, MI 48126

X1.3 ASTM Test Monitoring Center -

ASTM Test Monitoring Center, 6555 Penn Ave., Pittsburgh, PA 15206-4489

X1.4 Test Sponsor -

[Ford Motor Company, 17225 Federal Drive, Allen Park, Ste. 200 Rm. P029, MI 48101](#)

X1.5 Aeroquip Hose and Fittings -
Aeroquip Corp., 1225 W. Main, Van Wert, OH 45891

X1.6 Fuel Information and Availability -;
Haltermann Products, 1201 S. Sheldon Rd., P.O. Box 249, Channelview, TX 79530-0429

X1.7 Intake-Air Humidity Instruments -
Alnor Dewpointer; also dewpoint meters by EG & G, Foxboro, Hy-Cal, General Eastern, Protimeter

X1.8 Heat Exchangers -
ITT Standard Heat Exchangers , Kinetics Engineering Corp., 2055 Silber Road, Suite 101, Houston, TX 77055

X1.9 Fuel Flow Measurement -
Mass fuel flowmeters, Micro Motion Corp., 7070 Winchester Circle, Boulder, CO 80301

X1.10 Parts Washer and Chemicals -
Better Engineering Manufacturing, 8361 Town Court Center, Baltimore, MD 21236-4964

X1.11 Crankcase and Intake Air Pressure Gages -
Dwyer Instrument Co., Junction of Indiana State Highway 212 and U.S. Highway 12, P.O. Box 373,
Michigan City, IN 46360

X1.12 Blowby Heat Exchanger Coolant -
Nacool 2000 Engine Cooling System Treatment , Nalco Chemical Co. Functional Chemicals Group, One Nalco Ctr.,
Naperville, IL 60566-1024

X1.13 Lubricants -
EF-411, local distributors of ExxonMobil products.

X1.14 Tygon Hose -
Cadillac Plastic Co. distributors, or The Norton Co., 12 East Avenue, Tallmadge, OH 44278

~~X1.15 Special Test Engine Tools -
To facilitate assembly and disassembly of the engine
Owatonna Tool Co., 2013 4th St., NW Owatonna, MN 55060~~

~~X1.16 Ultrasonic Parts Cleaner -
Tierra Tech model MOT500NS ultrasonic parts cleaner, or similar
Tierra Tech, 12252 S. Casey Cove, Riverton Utah, 84065~~

X1.17: Brulin 815 GD and 815 QR-DF, BHC (Formerly Brulin & Co, Inc.) -
2920 Dr Andrew J Brown Ave, Indianapolis, IN 46205

X1.18: Flex Hone -
Model: GB33432, W.W.Grainger, Inc., several locations, website www.grainger.com

X.1.19: Pneumatic Honing Drill -
Westward 1/2 Reversible Air Drill, Model: 5ZL26G , W.W.Grainger, Inc., several locations, website
www.grainger.com

X1.20: Penmul L460 -
Penetone Corp., P.O. Box 22006, Los Angeles, CA 90022

~~X1.21: Parts Cleaning Soap -
(NAT 50 or PDN 50), Better Engineering Manufacturing, 8361 Town Court, Baltimore, MD 21236.~~

X1.22: Sanford Piston Ring Grinder –
Sanford Mfg. Co., 300 Cox St., P.O. Box 318, Roselle, NJ 07203.

X1.23: 3/16 in. carbide ring cutting burr -
No. 74010020, M. A. Ford.

X1.24: Sunnen soft stone -
No. JHU-820 Sunnen, Inc., 7910 Manchester, St. Louis, MO 63143.

X1.25: Ford camshaft alignment tool –
(Ford P/N 303-1565), Ford or Lincoln dealer

X1.26: Crankshaft TDC timing peg –
(Ford P/N 303-507), Ford or Lincoln dealer

X1.27 Dynamometer –
Dyne Systems, Inc., W209 N17391 Industrial Drive, Jackson, WI 53037
Dyno One, Inc. 14671 N 250, W Edinburg, IN 46124 <info@dyno-one.com>

X1.28 Various Materials—
Oil pan and baffles, oil screen, flywheel, clutch, pressure plate, spacer, bell-housing, dynamometer and engine wire harnesses
OH Technologies, 9300 Progress Pkwy., Mentor, OH 44060, and/or --- Test Engineering, Inc., 12758 Cimarron Path, Ste. 102, San Antonio, TX 78249-3417

X1.29 Oil separator -
Moroso Part number 85487, American Muscle Summit Racing

X1.30 Type 5 or Type 52 intercooler
FrozenBoost.com

X1.31 Chain Measurement Apparatus,
~~MCMR 1000, Lubrizol Corp. 29400 Lakeland Blvd., Wickliffe, OH 44092, attn.: George Szappanos,
George.Szappanos@lubrizol.com~~
Test Engineering, Inc., 12758 Cimarron Path, Ste. 102, San Antonio, TX 78249-3417

X1.32 Powertrain Control Module
Ford Motor Company, 17225 Federal Drive, Ste. 200 Room P029, Allen Park, MI 48101, attn.: Ron Romano,
<romano@ford.com>

X1.33 Shell Zone Dex-Cool
Keller-Heartt Oil, 4411 S. Tripp Ave., Chicago, Ill. 60632

X1.34 Chemtool B-12
Berryman Products, Inc., 3800 E. Randol Mill Rd., Arlington, TX 76011

X1.35 Ford Racing Balance Shaft Delete Kit –
(Ford P/N M-6026-23-BSBP), Ford or Lincoln dealer

X1.36 Crankshaft Sensor Alignment Tool-
(Ford P/N 303-1521), Ford or Lincoln dealer

X1.37 Driveshaft–
Machine Service Inc., 1000 Ashwaubenon St., Green Bay, WI 54304

~~X1.38 Coolant and fuel micromotion flow meter~~

Micro Motion Inc., 7070 Winchester Cir, Boulder, CO 80301

X1.39 Blowby Heat Exchanger -
Standard Xchange a Xylem Brand, 175 Standard Pkwy, Buffalo, NY 14227-1233

X2. Engine Brackets

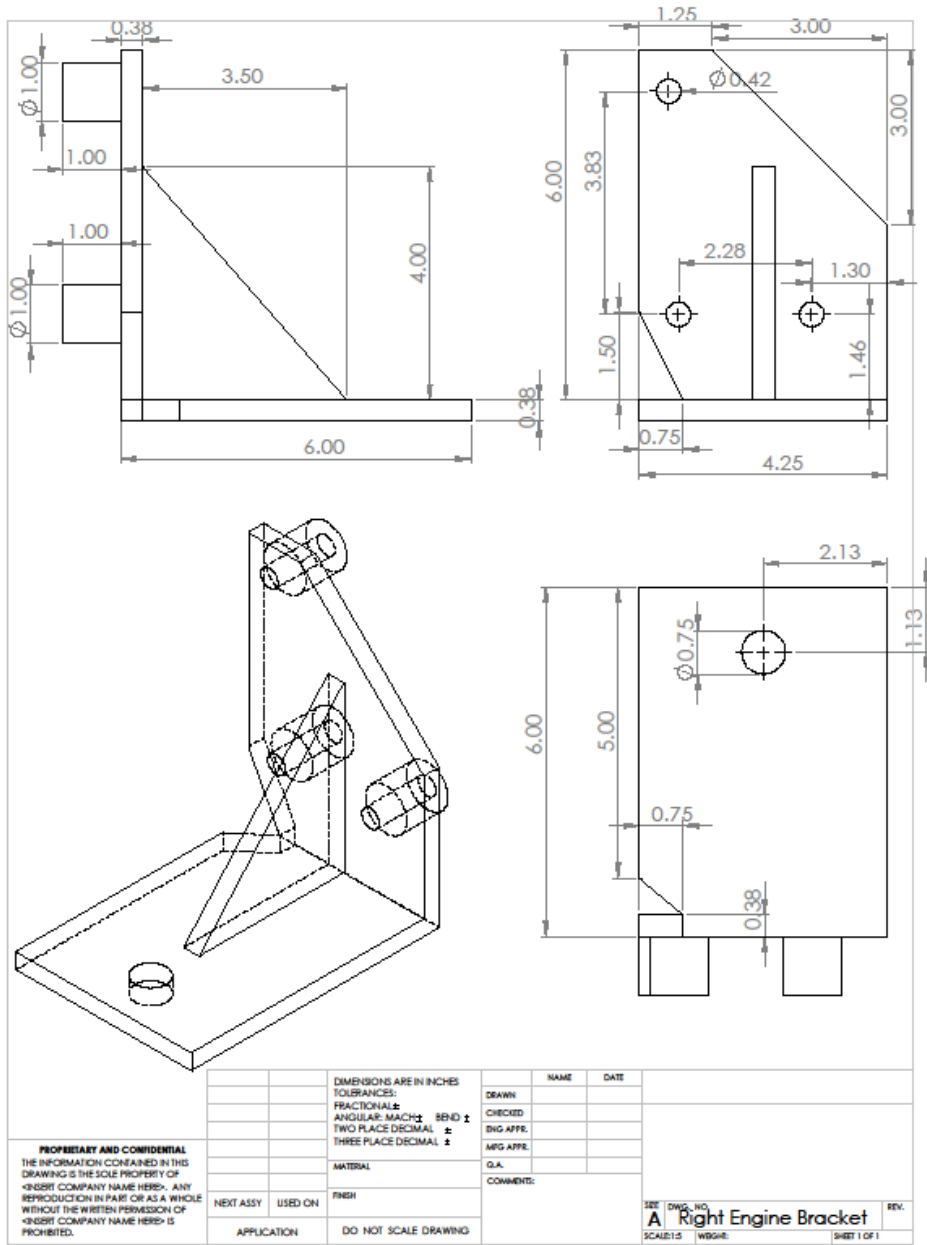
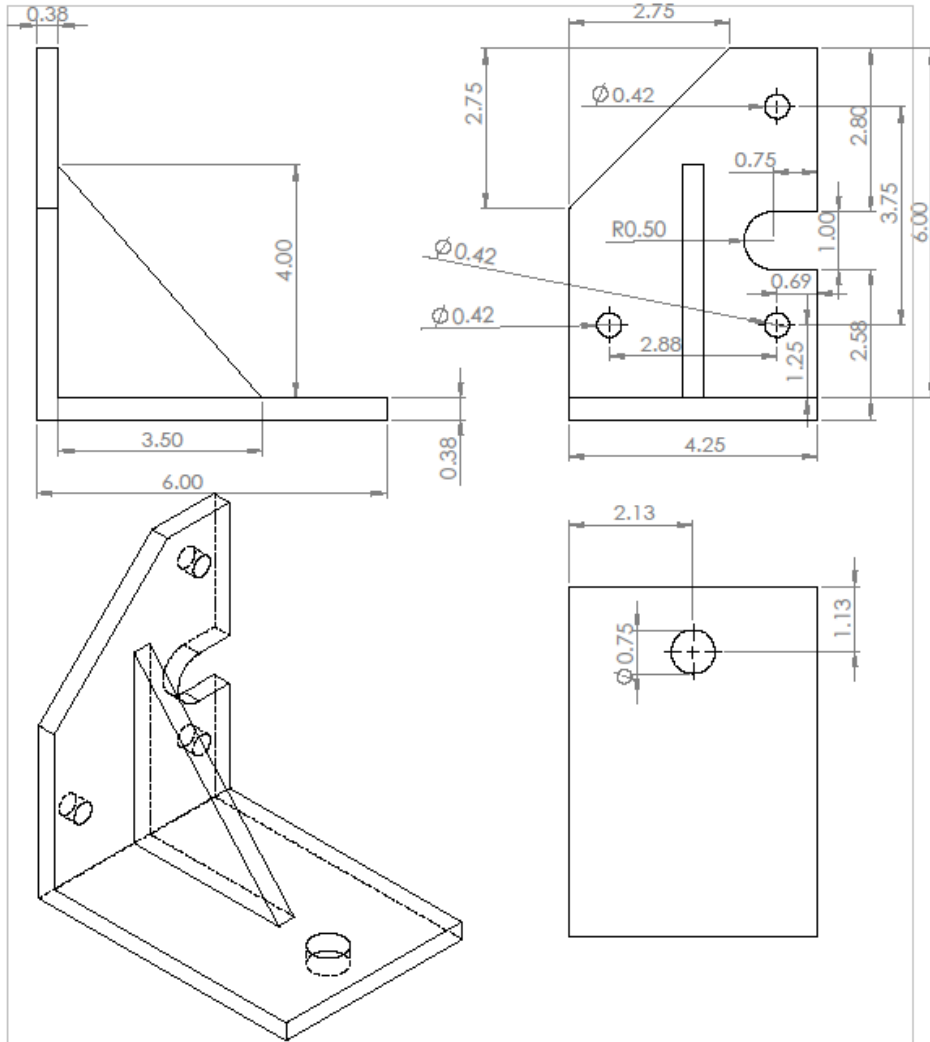

Fig. X2.1 Right Engine Bracket



<p>PROPRIETARY AND CONFIDENTIAL THE INFORMATION CONTAINED IN THIS DRAWING IS THE SOLE PROPERTY OF <ESBT COMPANY NAME HERE>. ANY REPRODUCTION IN PART OR AS A WHOLE WITHOUT THE WRITTEN PERMISSION OF <ESBT COMPANY NAME HERE> IS PROHIBITED.</p>		DIMENSIONS ARE IN INCHES TOLERANCES: FRACTIONALS: \pm ANGULAR: MACH: \pm BEND \pm TWO PLACE DECIMAL: \pm THREE PLACE DECIMAL: \pm		NAME	DATE
		MATERIAL: FINISH: APPLICATION: DO NOT SCALE DRAWING		DRAWN: CHECKED: ENG APPR: MFG APPR: Q.A. COMMENTS:	
NEXT ASSY	USED ON			SET DWG. NO. A Left Engine Bracket	REV.
				SCALE: 1:1	SHEET 1 OF 1

X2.2 Left Engine Bracket

Dip Stick Level (mm)	Oil Charge (gm)		Dip Stick Level (mm)	Oil Charge (gm)		Dip Stick Level (mm)	Oil Charge (gm)
160	4915		99	2577		38	1100
159	4866		98	2529		37	1084
158	4769		97	2505		36	1068
157	4720		96	2480		35	1060
156	4623		95	2431		34	1052
155	4574		94	2407		33	1044
154	4525		93	2383		32	1035
153	4501		92	2371		31	1027
152	4477		91	2359		30	1019
151	4379		90	2346		29	1011
150	4355		89	2334		28	1003
149	4331		88	2310		27	995
148	4233		87	2285		26	986
147	4185		86	2236		25	978
146	4136		85	2212		24	970
145	4087		84	2188		23	966
144	4038		83	2164		22	963
143	4014		82	2139		21	959
142	3990		81	2115		20	955
141	3965		80	2090		19	951
140	3940		79	2058		18	948
139	3916		78	2025		17	944
138	3892		77	1993		16	940
137	3844		76	1944		15	936
136	3795		75	1920		14	933
135	3746		74	1896		13	929
134	3697		73	1872		12	925
133	3673		72	1847		11	922
132	3649		71	1798			
131	3624		70	1774			
130	3600	Full Mark	69	1749			
129	3502		68	1733			
128	3454		67	1717			
127	3430		66	1701			
126	3405		65	1652			
125	3357		64	1628			
124	3308		63	1603			
123	3259		62	1587			
122	3235		61	1571			
121	3210		60	1555			
120	3162		59	1531			
119	3138		58	1506			
118	3113		57	1482			
117	3064		56	1457			
116	3016		55	1433			
115	2967		54	1409			
114	2943		53	1360			
113	2918		52	1344			
112	2870		51	1327			
111	2846		50	1311			
110	2821		49	1287			
109	2797		48	1262			
108	2772		47	1246			
107	2756		46	1230			
106	2739		45	1214			
105	2723		44	1198			
104	2699		43	1181			
103	2675		42	1165			
102	2659		41	1149			
101	2642		40	1132			
100	2626	Min	39	1116			

Table 10
Typical Dipstick Oil Level to Charge Conversions

