

6. Apparatus (General Description)

6.1 The test engine is a Ford, spark ignition, four stroke, 4-cylinder gasoline turbocharged direct injection (GTDI) engine with a displacement of 2.0 L. Features of this engine include variable camshaft timing, dual overhead camshafts driven by a timing chain, four valves per cylinder and electronic direct fuel injection. It is based on the Ford Motor Co. 2012 Explorer engine with a displacement of 2.0 L.

6.2 Configure the test stand to accept a Ford 2.0L GTDI engine. All special equipment necessary for conducting this test is listed herein.

6.3 Use the appropriate air conditioning apparatus to control the temperature, pressure, and humidity of the intake air to meet the requirements in [Table 4](#).

6.4 Use an appropriate fuel supply system ([Fig. 1](#)).

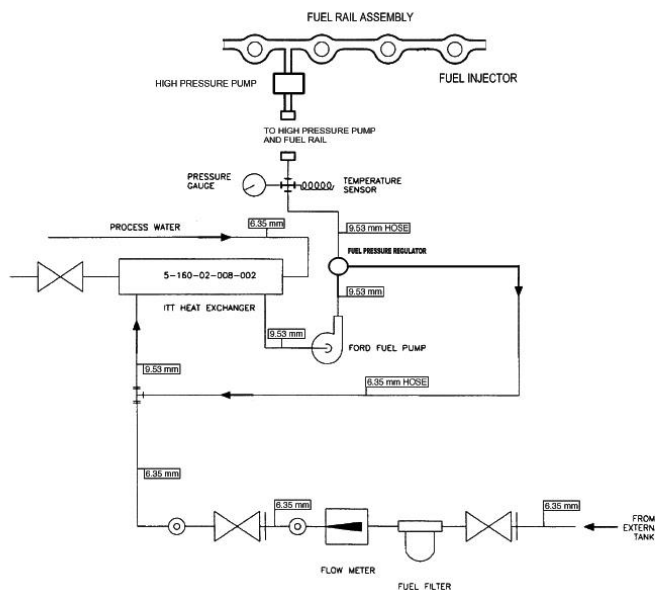

Figure 1

6.5 The control and data acquisition system shall meet the requirements listed in [Annex XX](#).

7. Apparatus (The Test Engine)

7.1 **Sequence??** Test Engine—The test engine parts are available from the Ford Motor Co. ([A1.1](#), use parts list .xl). A detailed listing of all parts is given in [Annex \(A1, use parts list .xl\)](#).

7.1.1 Engine parts other than valve train and drive parts can be replaced during the test, provided the reason for replacement was not oil related.

7.2 Required New Engine Parts—Use new parts listed in test parts list ([see A1.4](#)) and the gaskets list ([A1.5](#)) for each test. New valve train drive parts and piston rings must be used for each test. Do not modify or alter test parts without the approval of **Sequence ??** Surveillance Panel.

7.3 Reusable Engine Parts—The parts listed in the reusable engine parts list ([A1.2](#)), test stand set up kit ([A1.6](#)), and fastener kit ([A1.3](#)) can be reused (all of these can be used in numerous engine assemblies as long as they remain serviceable). Crankshaft and bearings, connecting rods and bearings, pistons, camshafts, timing chain covers, cylinder blocks, cylinder head assemblies, turbocharger, PCV valve and fuel injectors may be used for a maximum of 6 tests as long as they remain serviceable. **The PCV valve is flow tested before each test to insure it meets the required flow.** These parts should be kept together as a set for all 6 tests. Damaged threads in the block can be corrected with commercially available thread inserts.

7.4 Specially Fabricated Engine Parts—The following subsections detail the specially fabricated engine parts required in this test method:

7.4.1 Intake Air System ([see Fig. A2.12](#)) Intake air system can be fabricated but must use the stock 2012 Explorer air cleaner assembly ([A1.6](#)) and MAF.

7.4.5 Oil Pan and pick up tube—Use a modified oil pan with dipstick, fill port and pick up tube listed in [A1.7](#) and shown in [Fig. A2.1](#). These can be obtained from the supplier listed in [A9.2](#).

7.4.7 Driveline—Use the flywheel, clutch, pressure plate, bell housing, clutch spacer listed in [Annex \(A1.7\)](#) from the supplier listed in [A9.2](#).

7.5 Special Engine Measurement and Assembly Equipment—Items routinely used in laboratory and workshop are not included. Use any special tools or equipment shown in the 2012 Explorer service manual for assembly. A list of these tools is shown in [Annex A1.8](#). Complete any assembly instructions not detailed in Section 7 according to the instructions in the 2012 Explorer Service Manual.

7.5.1 Piston Ring Positioner—Use the piston ring positioner to locate the piston rings from the cylinder block deck surface by 38 mm. This allows the compression rings to be positioned in a consistent location in the cylinder bore for the ring gap measurement. Fabricate the positioner according to the details shown in [Fig. A2.17](#).

7.5.2 Piston Ring Grinder—A ring grinder is required for adjusting ring gaps. A suitable ring grinder is noted in [7.8.5.1](#).

7.5.4 Engine Service Tools—A complete list of special tools for the test engine is shown in [Annex A1.8](#). The tools are available from a Ford dealership. These are designed to aid in performing several service items, in addition to the following specific service items that require special tools to perform the functions indicated (if not self-explanatory).

7.5.7 Engine Parts Cleaning—Clean the cylinder block, cylinder heads, pistons, oil pan and front cover using Tierra Tech model MOT500NS ultrasonic parts cleaner or similar apparatus. See [X2.1.18](#). Rinse parts with parts cleaning soap, NAT-50 or PDN-50 ([Annex X2.1.23](#)) before putting into ultrasonic cleaner.

After all the measurements, the engine is ready for cleaning. Put all of the following components into ultrasonic parts cleaner for 30 minutes:

- Cylinder block with main bearings. Oil jets are removed.
- Bare pistons without wristpins (The piston compression and oil rings are removed from each piston prior to going into the ultrasonic cleaner, they will get replaced with a new set)
- Bare cylinder head (No valvetrain components)
- OHT oil pan
- Front cover

The ultrasonic parts cleaner solution is also provided by Tierra Tech, Ultrasonic solution 7 and B ([X2.1.19](#)). The cleaning procedure is described below:

Add solution once ultrasonic machine reaches a minimum of 140°F. DO NOT add the degreasers until the ultrasonic machine has reached a temperature of 140°F.

a. 5 ½ gallons of ultrasonic solution 7

b. ½ gallon of ultrasonic solution B

c. Change the soap and water solution at least after every 25 hrs. of use.

*Note: The solution shown above is based upon the MOT-500NS model (158 gallon capacity). Quantities will be different for a different size unit.

After 30 minutes, the parts are removed and immediately sprayed with hot water, then solvent and left to air dry.

The remaining components are spray cleaned with Stoddard solvent then blown out with pressurized air and left to air dry:

- Camshafts and all valve train.
- Intake manifold/ Throttle body (not being separated)
- Fuel pump housing with piston.
- Vacuum pump and oil screen.
- Intake and outlet of the turbocharger are lightly wiped down with solvent. The oil screen is also cleaned. (We don't clean the inside of the turbocharger)
- The carbon build up on the injectors is wiped of
- Oil Pump
- VCT solenoids are sprayed with solvent.
- Valve Cover
- Turbo charger oil lines
- Oil separator (PCV housing on the cylinder block)
- Oil pick up tube
- Oil squirters/jets
- Crankshaft
- Rods and pins

- All valvetrain
- The test batch camshaft sprockets and crankshaft gear.
- The test batch timing chain is cleaned as described in the Timing Chain Cleaning Procedure.

7.5.8 Cylinder Deglazing—Use a flexible cylinder hone Flex Hone Model: GB31232 and Pneumatic Honing Drill, Westward 1/2 Reversible Air Drill, Model: 5ZL26G to deglaze the cylinder walls. See [X2.1.20](#) and [X2.1.21](#)

7.5.9 PCV Valve Flow Rate Device:

7.59.1 Use this device to verify the flow rate of the PCV valve before the test and measure the degree of clogging after the test. Fabricate the device according to the details shown in Fig. A2.22. The device shall have a full scale accuracy of 5 % and a resolution of 0.05 L/s (see 7.6.7).

7.6 Miscellaneous Engine Components-Preparation:

7.6.1 Engine Build-Up and Measurement Area-Environment—The ambient atmosphere of the engine buildup and measurement areas shall be reasonably free of contaminants. A relatively constant temperature (within ± 3 °C) is necessary to ensure acceptable repeatability in the measurement of parts dimensions. To prevent moisture forming on cold engine parts that are brought into the buildup or measurement areas, maintain the relative humidity at a nominal maximum of 50 %.

7.6.2 Throttle Body:

7.6.2.1 Clean the butterfly and bore of the throttle body with carburetor cleaner (Chemtool B12) (X2.1.34) and air-dry before each test. Do not disassemble the throttle body as this will cause excessive wear on the components. The idle air screw can be removed for the cleaning process. Fully close the idle air screw during test operation.

7.6.2.2 There is no specific life for the throttle body. However, the clearance between the bore and the butterfly will eventually increase and render the body unserviceable. When the clearance becomes too great to allow control of speed, torque, and air-fuel ratio, discard the throttle body.

7.6.3 PCV Valve—Measure and record the flow rates of the PCV valve with the calibrated flow device described in 7.5.9 and Fig. A3.19. Measure the flow rate at (27 and 60) kPa vacuum. Because of the hysteresis in the PCV valve spring, make the vacuum adjustments in one direction only. Measure the flow rate twice and average the readings. Reject any PCV valve that does not exhibit an average flow rate of (36 - 54) L/min at 27 kPa and (19 to 21) L/min at 60 kPa

7.6.4 Water Pump Drive System—Use only the pulleys and belt provided in the [Sequence ??](#) test stand set-up parts list (see [Annex A1.6](#)), crankshaft pulley, water pump and pulley, tensioner, and six groove belt shown in [Figure 6](#).

7.6.5 Oil Separators—Clean with degreasing solvent ([7.7.1](#)) and allow to air-dry.

7.7 Solvents and Cleaners Required—No substitutions for [7.7.1 – 7.7.5](#) are allowed. (Warning—Use adequate safety provisions with all solvents and cleaners. See [Annex X1](#).)

7.7.1 Solvent—Use only mineral spirits (ie Stoddard Solvent) meeting the requirements of Specification D235, Type II, Class C for Aromatic Content (0 to 2) vol %, Flash Point (61 °C, min) and Color (not darker than +25 on Saybolt Scale or 25 on Pt-Co Scale). (Warning—Combustible. Health hazard.) Obtain a Certificate of Analysis for each batch of solvent from the supplier.

7.7.2 Organic Solvent, Penmul L460. (Warning—Combustible. Health hazard.). [Annex X2.1.22](#)

7.7.4 Ultrasonic Cleaner, Tierra Tech ultrasonic solution 7 and B available from supplier shown in [Annex X1.4](#).

7.7.5 Parts Cleaning Soap, NAT-50 or PDN-50 have been found to be acceptable. (Warning—Health hazard.) [Annex X2.1.23](#)

7.8 Assembling the Test Engine-Preparations—Use the long block obtained from the supplier in [A9.1](#). If this is the first test on a new engine, disassemble the long block in accordance with the 2012 Explorer workshop manual. Required new parts and reusable parts are listed in [Annex A1](#).

7.8.1 Parts Selection—Instructions concerning the use of new or used parts are detailed in [7.1.1](#), [7.2](#), and [7.3](#).

7.8.2 Sealing Compounds—Use a silicon-based sealer as needed on the contact surfaces between the rear seal housing and oil pan and the front cover and cylinder block, cylinder head and oil pan. Use Motorcraft Gasket Maker between (TA-16) or equivalent between the 6th intake and exhaust camshaft cap and the cylinder head.

7.8.2.1 Use silicon-based sealer sparingly since it can elevate the indicated silicon content of the used oil.

NOTE 1—Non-silicon liquid or tape thread sealers can be used on bolts and plugs.

7.8.3 Gaskets and Seals—Install new gaskets and seals during engine assembly.

7.8.4 Block Preparations—Inspect block, including oil galleries for debris and rust. Remove any debris or rust that is found. Remove oil gallery plugs. Removal of coolant jacket plugs is left to the discretion of the laboratory.

7.8.4.1 **Deglazing Procedure:** Deglazing is performed after ultrasonic cleaning under the following conditions to achieve a 9ra to 13ra and 30+5 degree crosshatch:

1. Mount the engine block in an engine stand or suitable fixture so it is secure and will not move during deglazing operation.
2. Rinse cylinder bores with Stoddard solvent.
3. Deglaze cylinder bores using drill and hone shown in Figure 3 and Figure 4.
4. Run the drill at 500 rpm horizontal drill speed for 25 to 35 vertical strokes over elapsed time of 20 to 25 seconds. There should be a steady supply of lubricant supplied during each stroke.
5. 50/50 ratio, Stoddard Solvent (mineral spirits) and EF411, is the hone lubricant used.
6. Clean cylinders after honing deglazing with warm/hot water or hot water and Tide detergent using a brush, then oil cylinders with EF411.
7. Replace ball hone after deglazing 24 engine blocks
8. Measure surface finish and crosshatch.



Figure 3: Pneumatic Honing Drill

Pneumatic Honing Drill

Brand: Westward

1/2 Reversible Air Drill

Model: 5ZL26G

RPM: 500

Max Psi: 90



Figure 4: Cylinder Hone

Flexible Cylinder Hone

Brand: Flex Hone

Model: GB31232

Bore Dia.: 3-1/2"

Abrasive Material: Silicon Carbide Grit 320

7.8.4.2 Crosshatch Procedure:

Materials:

1. Hatchview Software (<http://digitalmetrology.myshopify.com/products/hatchview>) (X2.1.24)
2. USB microscope. (X2.1.25)
3. Computer System Requirements: Windows XP, Vista or Windows 7 (32 or 64 bit), an available USB 2.0 port is required for live “video” viewing.

Preparation:

1. Cylinder should be clean of any oil or residue from honing to maintain consistency of measurements.
2. Adjust focus of camera while face of the camera is placed against the cylinder wall.
3. Set camera resolution to 640x480 and 30 fps.
4. Use the identification feature available in the program to title the image with cylinder number and test number.

Measurement:

1. The measurement is taken at the rear most longitudinal position of each cylinder.
2. The measurement is taken at 1.5 in. down from the top of the cylinder deck. A ruler is used to measure.
3. The measurement is to range for 25° to 35° with a target of 30°

7.8.4.3 Crankshaft preparation

- (1) Clean the crankshaft according to section 7.5.7
- (2) Spray the crankshaft with degreasing solvent.
- (3) Measure the main journals and connecting rods journals (horizontal diameter, vertical diameter) bearing inside diameter and clearance and verify that they meet the service limits.

(5) The crankshaft is polished with 400 grit 3M utility cloth while it is still lightly coated in Stoddard solvent. A final finish is given using 600 grit crocus cloth. The crankshaft is cleaned with Stoddard solvent for the final time.

7.8.4.4 Piston and rod assembly: Clean the pistons according to section 7.5.7. Measure piston, piston pin and pin rod hole diameters to insure they meet service limits. Install the pistons on the connecting rods per the procedure in the 2012 Explorer workshop manual.

7.8.5 Piston Rings:

7.8.5.1 Ring Gap Adjustment:

The piston rings are cleaned and wiped with EF411 to get the factory coating off. The 1st ring is gapped to .065” and the second ring is gapped to .070”. These gaps have been shown to produce acceptable blowby levels with the surface finish and crosshatch pattern achieved in 7.8.4.1. but may need to be adjusted to achieve a 24 hour minimum blowby level of 70 L/min and an average blowby of 65-75 L/min. The ring placement is 1.5” (38mm) from the deck using ring positioner shown in Figure A2.17.

7.8.5.2 Piston Ring Cutting Procedure:

(1) Cut the top and second compression ring gaps to the required gap using the Sanford Piston Ring Grinder. (X2.1.26) ring cutting burr (X2.1.27) rotated at a rated speed of 3450 r/min. Remove equal amounts from both sides of the gap. Make final cuts on the down stroke only. The ring is cut with a maximum increment of 0.125 mm until the desired ring gap is achieved.

(2) After the rings are cut remove the ring from the cutting tool, debur using a Sunnen soft stone (X2.1.28) and wipe with a dry towel.

7.8.5.3 Installation:

(1) Install the oil control rings and the compression rings on the pistons with the gaps located over the piston pin. Position the gaps at approximately 180° intervals, with the top compression ring gap toward the rear. Install the rings using a ring spreader tool, keeping the rings' surfaces parallel to the ring groove in the piston.

(2) If any rings require replacement, then measure and record the new ring gap(s) and ring side clearance(s). Calculate ring side clearance by determining the difference between the ring groove width and the associated ring width.

7.8.6 Cylinder Bore Measurements—Measure the cylinder bores with the bearing caps in place. Clean the bores with a dry rag. The bores shall be clean and dry when they are measured. Use a bore gage micrometer to determine the diameter of cylinders at the top, middle and bottom using the bore ladder shown in figure A2.18.

7.9 Assembling the Test Engine-Installations—Assemble the engine according to the instructions in the 2012 Explorer service manual unless specified herein.

7.9.1 Cylinder block— The heater hose tube is removed from the block as shown in Figure 5 and plugged with a 5/8” freeze plug coated in RTV.



Figure 5: Cylinder Block Heater Hose Tube

7.9.2 Piston Installation—Install piston and rod assemblies in proper cylinders, taking care to ensure rings are not damaged during installation. Wipe the cylinders with EF-411. Install the pistons and connecting rods with the notches facing the rear. Install the rod bearing caps and torque according to the procedure in the 2012 Explorer workshop manual.

7.9.3 Oil System Components—All oil system components in the engine are production configuration with the exception of the oil pan and the oil pickup tube, shown in figure A2.1.

7.9.4 Cylinder Head Installation—Cylinder heads are obtained from the supplier in A9.1. Heads may be used for up to 6 tests, as long as they remain serviceable.

(1) Disassemble heads and inspect for any debris or other deleterious materials and remove as necessary.

(2) Clean the cylinder head in the Ultrasonic cleaner as described in section 7.5.7.

(3) Determine valve guide clearance at the top and middle of the heads on the transverse side of the guide. Reject any heads that exceed the service limits shown in the 2012 Explorer work shop manual.

(4) Measure and record intake and exhaust valve springs, spring free length, and spring load at a compressed height of 28.7 mm. Verify the compressed spring load is 460 ± 21 N. Reject any springs not meeting this criteria.

(5) Assemble the cylinder heads in accordance with the service manual. The valves are lapped before installation and new intake and exhaust valve seals are installed.

(6) Set the valve lash per the procedure in the workshop manual and record the valve lash.

7.9.5 Chain and Camshaft Installation Procedure: Measure the test chain according to the Timing Chain Measurement Procedure prior to installing it in the engine. Install camshaft and timing chain according to the procedure in the 2012 Explorer work shop manual. If using the Ford camshaft alignment tool (Ford P/N 303-1565) (X2.1.29) be sure not to let it bind in slots at the rear of the camshafts. It should be loose after the timing chain installation is complete. Be sure camshaft positioning tool is flat before installing. Use a spanner on the harmonic

balancer or a flywheel lock to hold the crankshaft. Alternate method, the crankshaft positioning crankshaft TDC timing peg (Ford P/N 303-507) (X2.1.30) can be used to hold the crankshaft in place while performing this installation. Install the timing chain with the lettering on the black link facing forward. This will insure the chain is installed in the same orientation if/when it is removed and reinstalled during the test. Coat the timing chain with test oil every time it is installed in the engine other than the pre break in installation. The timing chain gets coated with EF-411 when it is first installed before break in. Install the chain tensioner and guides according to the 2012 Explorer workshop manual. After the tensioner is installed and the pin is pulled from the tensioner to release the tensioner arm, do not move or apply any force to the tensioner arm.

7.9.6 Balance Shaft Housing— Do not install the balance shaft housing; it cannot be used with the test oil pan. The balancer is removed and the oil passage is plugged with a CFM Balance Shaft Delete Kit (Part number 1-0180) (X2.1.31).

7.9.7 Oil Pan and Baffle—Install oil pan baffle to the oil pan as shown in Fig. A2.1. Install the oil pan according to the procedure in the 2012 Explorer service manual.

7.9.8 Water Pump, Water Pump Drive—Install the water pump and pulley, the crankshaft pulley, and tensioner according to the 2012 Explorer service manual. These are the only components needed to drive the water pump. All other production front end accessory drive components do not need to be installed. The engine cannot be used to drive any external engine accessory other than the water pump. Pull back tensioner and install water pump drive belt as shown in Fig. 6. Ensure that there is a minimum contact angle of 20° between the drive belt and the water pump pulley.

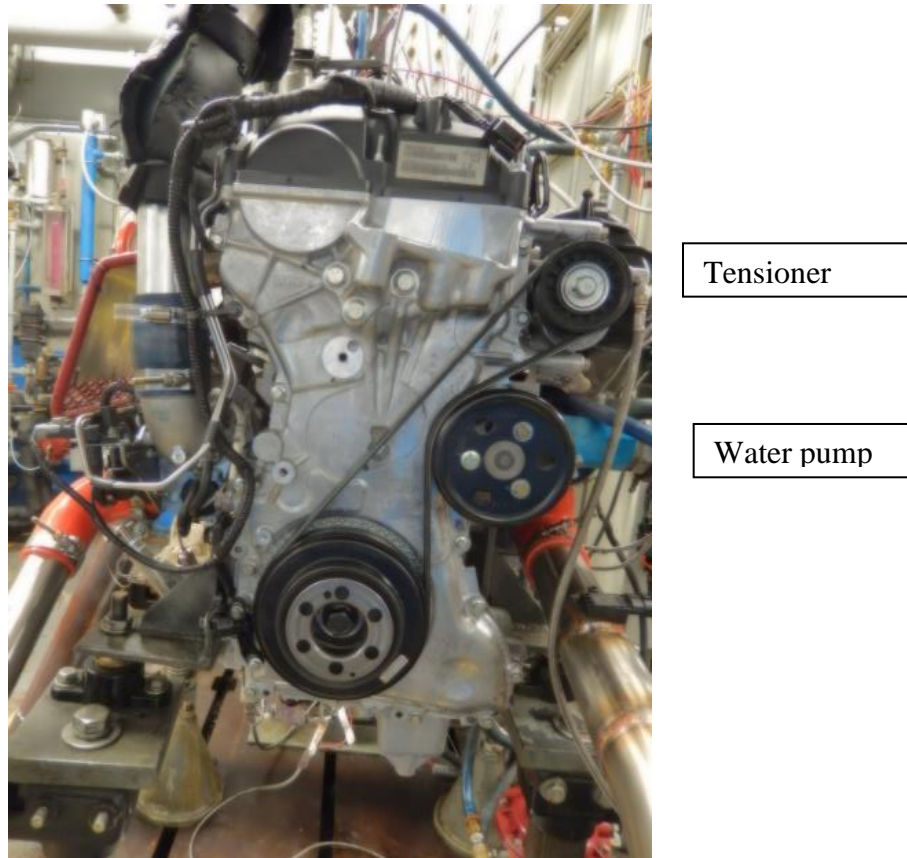

FIG. 6 Water Pump Drive Arrangement

7.9.9 Engine cooling system – Use coolant inlet and outlet from the supplier shown in A9.2. Plumb the external coolant system as shown in Figures A2.2 and A2.3. Use coolant flow meter with an accuracy of $\pm 1\%$.

7.9.10 Cylinder block oil separator - Install a dummy PCV valve (PCV valve with the internal components removed) in oil separator on the side of the engine block. A functional PCV is located at the stand in the external ventilation system. This is the location to measure crankcase pressure.

7.10 Chain Cleaning Procedure:

1. Place a brand new timing chain into an ultrasonic bath with Stoddard solvent for 20 minutes.
2. Remove the chain from the ultrasonic cleaner and dip into room temperature Stoddard solvent to cool chain. Dip the chain in heptane or solvent 142 to prevent rust before measuring.
3. Let the chain dry and cool off for a minimum of 2 hours in the metrology lab before starting the measurement procedure. This will allow the temperature of the chain to stabilize. Oil chain with EF-411 prior to pre-break in measurement. There is no need to coat the end of test chain with oil after cleaning.

(Note: Do not clean the timing chain if it is removed during the test for a repair)

7.11 Timing Chain Measuring Procedure: The timing chain is measured three times during the test; when the chain is new, before the initial installation into the engine, after the 8 hour engine break in and at the end of the test.

- Use the George-O-Matic chain measurement apparatus (A9.6) shown in [Figure 7](#).
- Parts list show in [A1.8](#)



Figure 7: Chain Measurement Apparatus

1. Check calibration standard on measurement apparatus. If the indicator reading is less than $\pm 0.0005''$ proceed to next step. If reading is larger, then investigate source of error.
2. Orient the sprockets of the measurement apparatus such that they are aligned with their alignment orientation marks.
3. Install chain on measurement apparatus with the “key” link in the standard (aligned) location.
4. Insure that the USB digital interface cable between the indicator and the computer is connected and that the first cell of the spreadsheet is selected into which the data will begin being entered.
5. Energize the drive motor on the chain measurement apparatus and run until a minimum of 30 chain lengths worth of reading have been captured (207 sprocket revolutions).
6. When complete, examine the averages for the three measurement ranges and verify the total range does not exceed $\pm 0.0003''$; if it does, repeat the measurement by overwriting the data.
7. Chain elongation = $2 * (\text{measurement} - \text{initial measurement}) / \text{nominal chain length}$. The nominal chain length is $43.125''$.

7.12 Engine Installation on the Test Stand—Functions that are to be performed in a specific manner or at a specific time in the assembly process are noted.

7.12.1 Mounting the Engine on the Test Stand—Mount the engine on the test stand so that the flywheel friction face

is $(0.0 \pm 0.5)^\circ$ from vertical. Four motor mounts are used (Quicksilver part# 6628-A) (X2.1.33) as shown in Figure A2.4 and Figure A2.5. Drawings of the mount brackets can be found in the Figure A2.6 and Figure A2.7. The engine must be at $(0.0 \pm 0.5)^\circ$ role angle.

7.12.1.1 Flywheel: The flywheel bolts get lightly coated with Loctite 565 to prevent any oil from seeping out of the holes. Torque the flywheel to 108-115 Nm. The flywheel is obtained from the supplier in A9.2

7.12.1.2 Clutch and pressure plate - The clutch, pressure plate and spacer are obtained from the supplier in A9.2. Put the flat side on the clutch toward the engine. The spacer goes between the flywheel and pressure plate. Torque the pressure plate bolts to 25-33 Nm. Each clutch gets replaced every 6 runs.

7.12.1.3 Driveline: The driveline is greased every test. Driveline specifications:

- A. Driveline Degree: 2 degrees
- B. 595 ± 13 mm installed length from flange to flange
- C. 1410 series flanges
- D. 2.75" pilot
- E. 3.75" bolt circle
- F. 3.50" x .083" stub and slip

7.12.2 Exhaust System and Gas Sampling Fittings:

7.12.2.1 A typical exhaust system, and fittings for backpressure probe, O2 sensors and thermocouple are illustrated in Figs. A2.8. Exhaust components should be constructed of either solid or bellows pipe/tubing. Other type flexible pipe is not acceptable.

7.12.2.2 The backpressure probe can be used until they become unserviceable. If the existing probes are not cracked, brittle, or deformed, clean the outer surface and clear all port holes. Check the probes for possible internal obstruction and reinstall the probes in the exhaust pipe. Stainless steel probes are generally serviceable for several tests; mild steel probes tend to become brittle after one test. Exhaust gas is noxious. (Warning—Any leaks in the connections to the sample probe will result in erroneous readings and incorrect air-fuel ratio adjustment.)

7.12.4 Fuel Management System:

7.12.4.1 Fuel Injectors:

(1) The fuel injectors can be used for 6 test.

(2) Inspect the O-rings to ensure they are in good condition and will not allow fuel leaks, replace if necessary. Install the fuel injectors into the fuel rail and into the cylinder head.

7.12.4.2 Powertrain Control Module: The engine uses a PCM provided by Ford Motor Company to run this test. The PCM contains a calibration developed for this test, use a PCM that contains calibration U5J0110D1VEPfn13_78_2. The PCM module is available from the supplier listed in A9.2.

(1) The PCM power shall come from a battery (13.5 ± 1.5) V or a power supply that does not interrupt/interfere with proper PCM operation. Connect the PCM battery/power supply to the engine wire harness with an appropriate gage wire of the shortest practical length so as to maintain a dc voltage of (12 to 15) V and minimize PCM electrical noise problems. Ground the PCM ground wire to the engine. From the same ground point, run a minimum two gage wire back to the battery negative to prevent interruption/interference of the PCM operation. The power supply can also be used for the Lambda measuring devices.

7.12.5 Spark Plugs—Install new Motorcraft CYFS-12-Y2 spark plugs. Spark plugs come pre-gapped. Torque the spark plugs to 9 to 12 N·m. Do not use anti-seize compounds on spark plug threads.

7.12.6 Crankcase Ventilation System—The crankcase ventilation system is a closed system allowing blowby to be vented from the crankcase and drawn into the intake manifold. The metal parts of the crankcase ventilation system get flushed with carburetor cleaner (Chemtool B12) (X2.1.34) or any equivalent solvent after every test, then blown out with pressurized air and are left to air dry. All the hoses (ie tygon) get replaced every test. If using a smooth bore Teflon braided stainless steel hose, these can be reused after cleaning in an industrial degreaser (Penmul L460). A diagram of the crankcase ventilation system is shown in Figure A2.9 and A2.10.

7.12.6.1 System description: - Blowby flows through the oil drain back passages in cylinder block and head and through the front cover and out through the camshaft cover. The blowby heat exchanger and oil separator prevents loss of oil, fuel and water into PCV system. A typical heat exchanger cooling system is shown if Figure A2.11. The PCV valve flows approximately 120 L/min. Blowby flowrate is 65 to 75 L/min. When excessive plugging of the PCV valve occurs or there is excess blowby, the blowby is vented to the fresh air tube after the mass air flow sensor. A dummy PCV valve (PCV valve with the internal components removed) is placed in the stock PCV valve location in the block mounted oil separator is used for crankcase pressure measurement.

7.12.6.2 Blowby Heat Exchanger and Oil Separator: Use ITT Heater exchanger S-160-02-008-002 (X2.1.9) and

Moroso oil separator, Part number 85487 (A9.4). Disassemble and soak both in Penmul L460 (X2.1.22) for 24hrs. Rinse with hot water, then rinse a final time with Stoddard solvent and let air dry.

7.12.7 Intake Air Components—Install the fresh air tube, air cleaner assembly, and new air filter. Modify the air cleaner assembly to accept fittings for inlet air temperature thermocouple and pressure tap as shown in Fig. A2.12. The excessive blowby tube is shown connected to the fresh air tube after the MAF sensor. Use the 2012 Explorer fresh air tubes or fresh air tubes can be fabricated but must be 1040 ± 25 mm from the MAF sensor to the turbocharger inlet.

7.12.7.1 Water to Air Turbocharger Intercooler - Use water to air intercooler (A9.5) capable of achieving the required air charge temperature and system pressure loss shown in Table ?. The intercooler accumulates significant amounts of blowby condensate during each test. The air side of the intercooler must be spray cleaned with Stoddard solvent, rinsed with hot water and left to air dry. Use commercial Aqua Safe descaler to clean the water side.

7.12.7.2 Intercooler Tubing: Fabricate the intake air system with 51 mm ID stainless steel tubing from the turbocharger to the intercooler and 64 mm ID stainless steel tubing from the intercooler to the throttle body. The tubing length is not specified but should be the appropriate length to achieve the required air charge temperature and system pressure loss. Locate the MAPT sensor 305 ± 25 mm from the intake surface of the throttle body and the intake air charge temperature thermocouple 1 inch downstream from the MAPT sensor. The post-intercooler turbo boost pressure measurement probe should be placed a minimum of 12 inches upstream from the MAPT sensor. The pre- intercooler turbo boost pressure measurement probe should be placed a minimum of 12 inches downstream from the turbocharger outlet. The measurements can be seen in Figure A2.13 and typical installation is shown in Figure A2.14.

7.12.8 External Hose Replacement—Inspect all external hoses used on the test stand and replace any hoses that have become unserviceable. Check for internal wall separations that could cause flow restrictions. Check all connections to ensure security.

7.12.9 Wiring Harness—There are two wiring harnesses used on the test stand, a dynamometer harness that connects to the stand power and PCM and an engine harness. Obtain the dynamometer wiring harness and engine wiring harness from the supplier listed in A9.2. Diagrams of these wire harnesses are shown in Figures A2.20 and A2.21 identifying connections.

7.12.10 Electronic Throttle Controller: Throttle is controlled using simulated accelerator pedal position signals. The dyno wiring harness is supplied with an Accelerator Pedal Position jumper cable with un-terminated pigtail leads. The test laboratory must connect two voltage command signals, Acc Pos Sensor 1 and Acc Pos Sensor 2, to the Accelerator Pedal Position jumper cable. The voltage control ranges for each signal are shown in Table 1. The wiring schematic and pin-out description for this connection is shown in Figure 8. The voltage signals must be run through a voltage isolator otherwise interference will occur between the lab DAC system and the engine ECU and throttle control will be erratic.

Command Signal	Operating Range	Min Signal (Idle)	Max Signal (WOT)
Acc Pos Sensor 1	0-5.0 VDC	0.75 VDC (15%)	4.25 VDC (85%)
Acc Pos Sensor 2	0-2.5 VDC	0.375 VDC (15%)	2.125 VDC (85%)
Note: Acc Pos Sensor 2 should always equal 50% of Acc Pos Sensor 1.			

Table 1: Accelerator Position Sensor Control Ranges

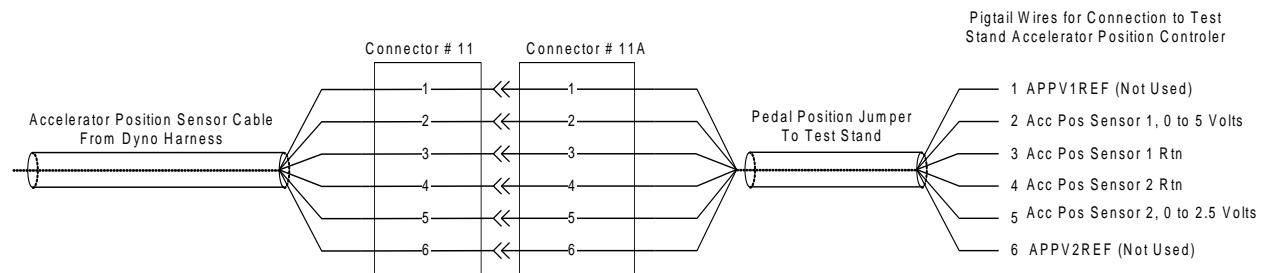
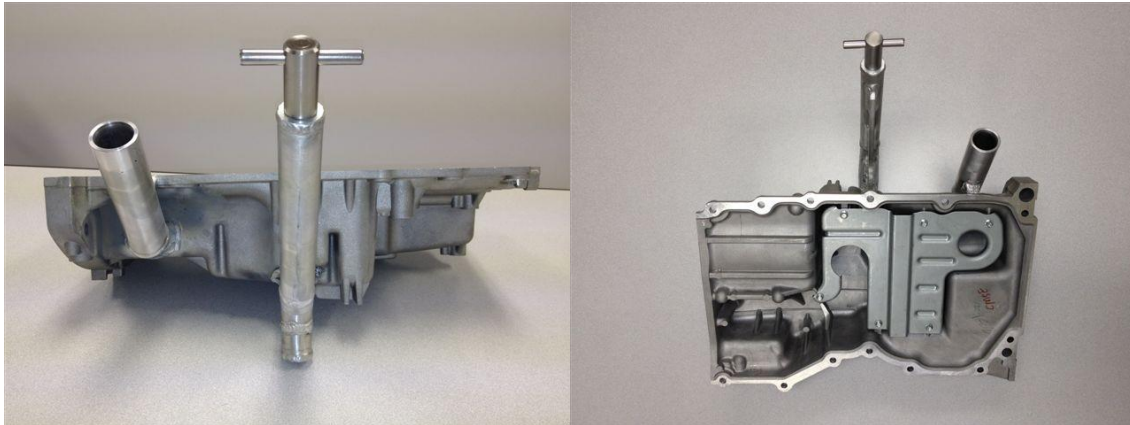
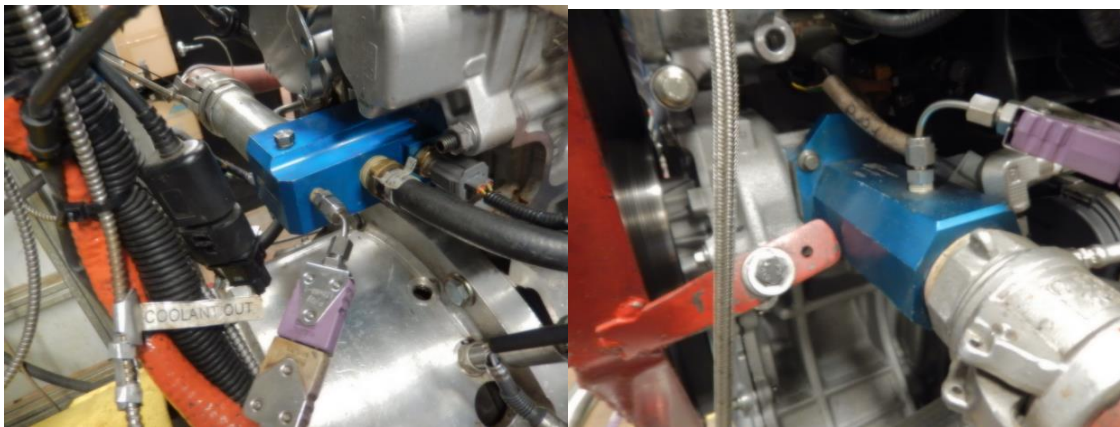

Figure 8: Accelerator Position Wiring Schematic

Annex A2



Oil pan
Figure A2.1



Coolant out

Coolant in

Coolant in and out connections and thermocouple locations
FIG. A2.2

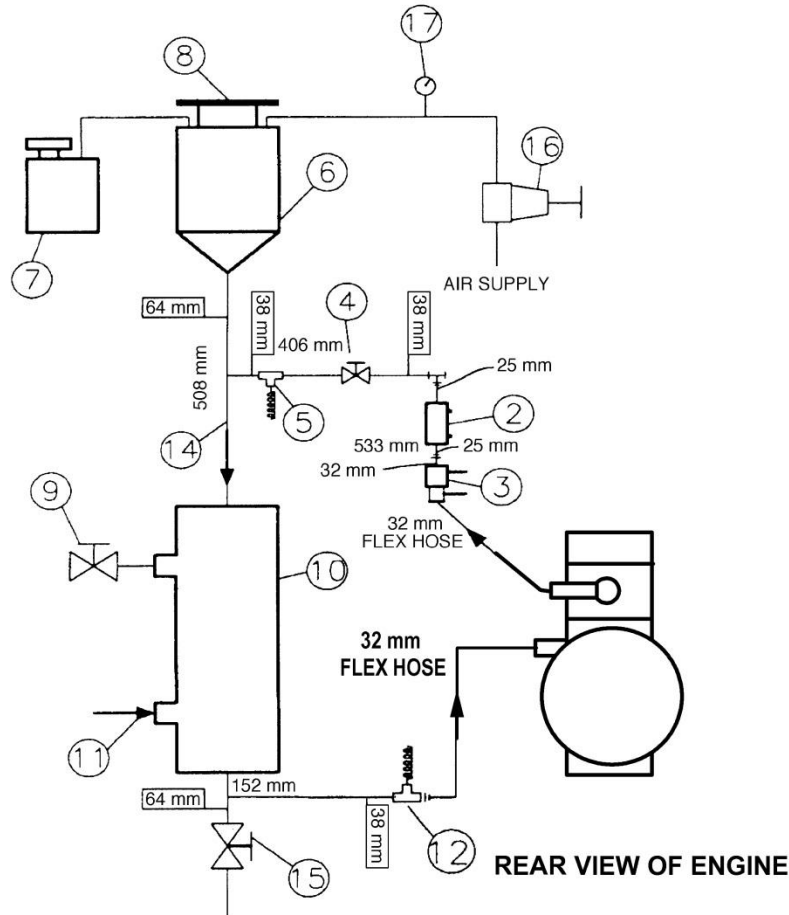

NOTE 1—Observe temperature sensor locations in thermostat housing and at water pump inlet.

NOTE 2—Components of Engine Cooling System—

- (1) Thermostat housing with temperature sensor
- (2) Sight glass
- (3) Flowmeter
- (4) Flow control valve
- (5) Optional temperature control sensor
- (6) Fabricated coolant reservoir
- (7) Constant full expansion tank
- (8) Pressure radiator cap (MOTORCRAFT RS40 P/N D2YY-8100-A)
- (9) Process water control valve (regulated by temperature controller with three remote set points)
- (10) Heat exchanger (ITT Standard P/N 5-030-06-048-001 TYP.)
- (11) Process water supply (shell side)
- (12) Tee with temperature sensor for coolant inlet; located (300 to 400) mm upstream of pump inlet at the block face
- (13) Water pump inlet (Oil filter adapter)
- (14) Engine coolant (tube side)
- (15) Coolant system drain valve
- (16) Coolant pressure regulator
- (17) Coolant pressure gage
- (18) External coolant pump

FIG. A2.3 Typical Engine Cooling System Schematic (cont.)

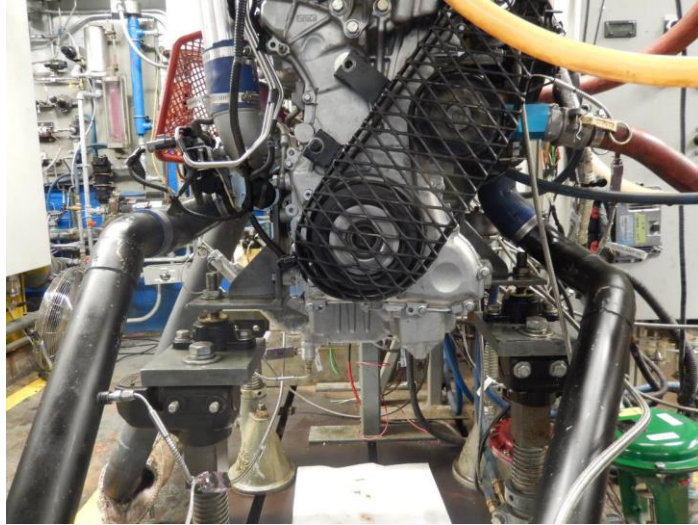

Figure A2.4: Motor mounts, front

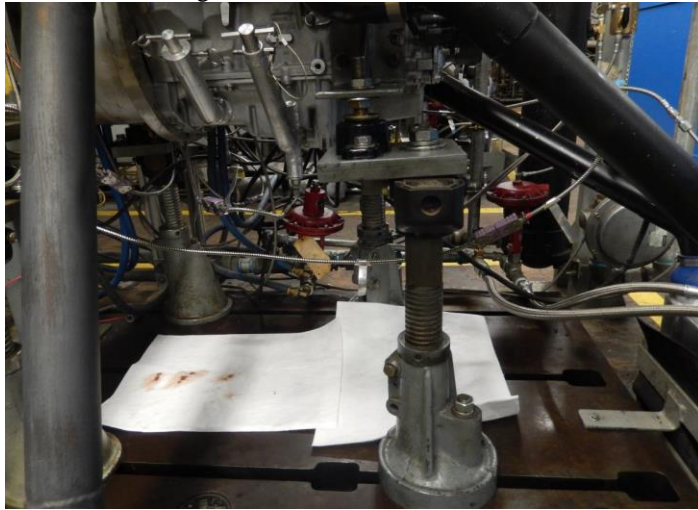

Figure A2.5: Motor mounts, rear

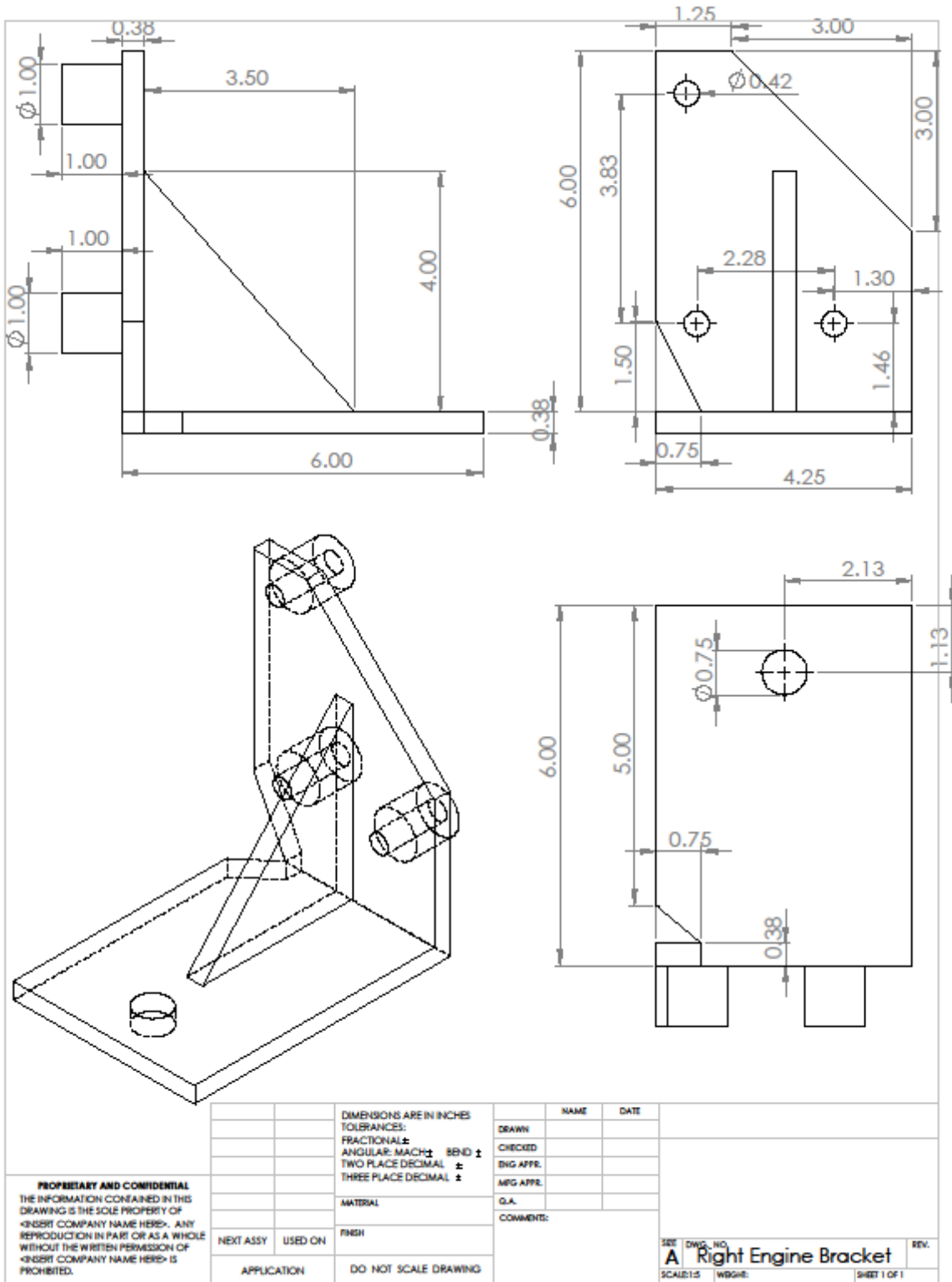

Figure A2.6

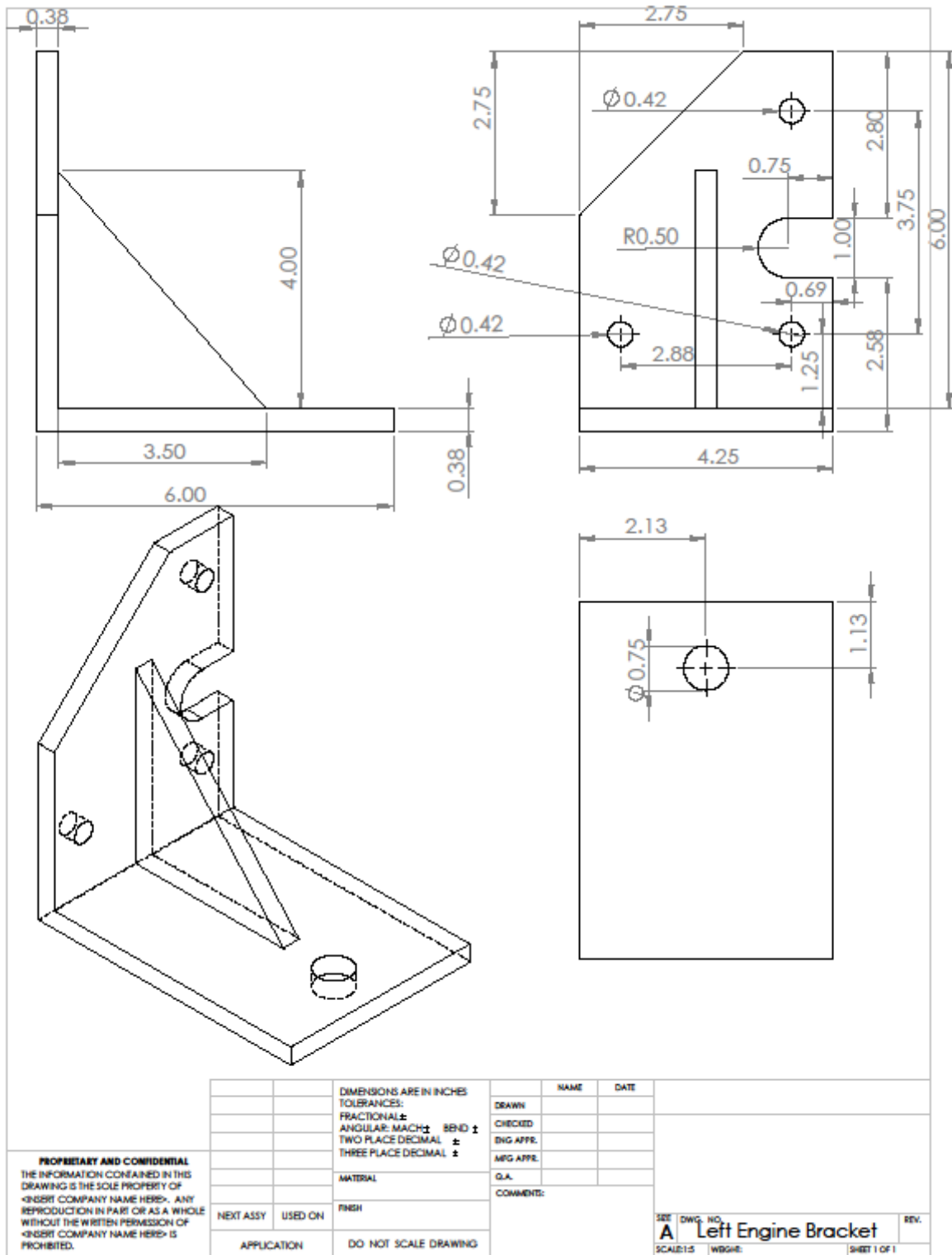

Figure A2.7

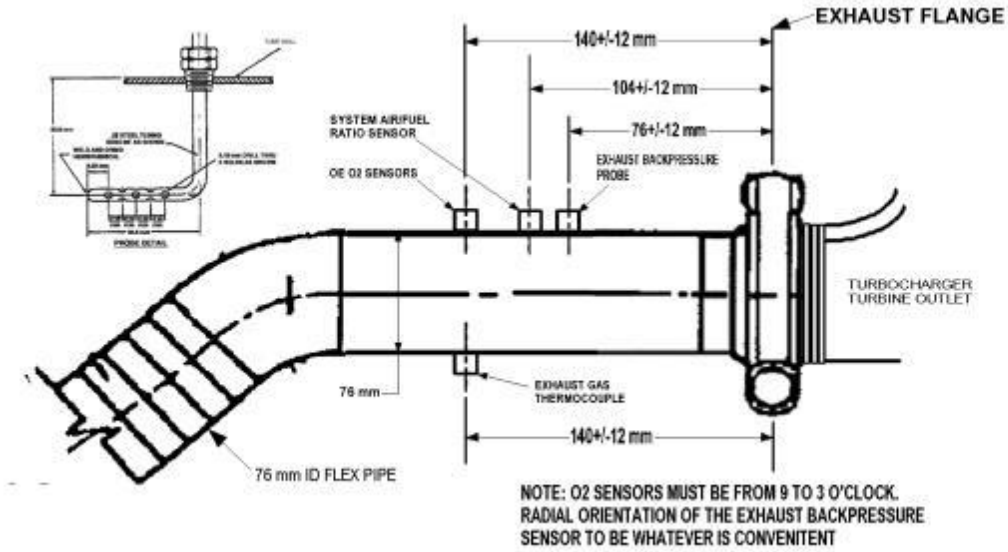
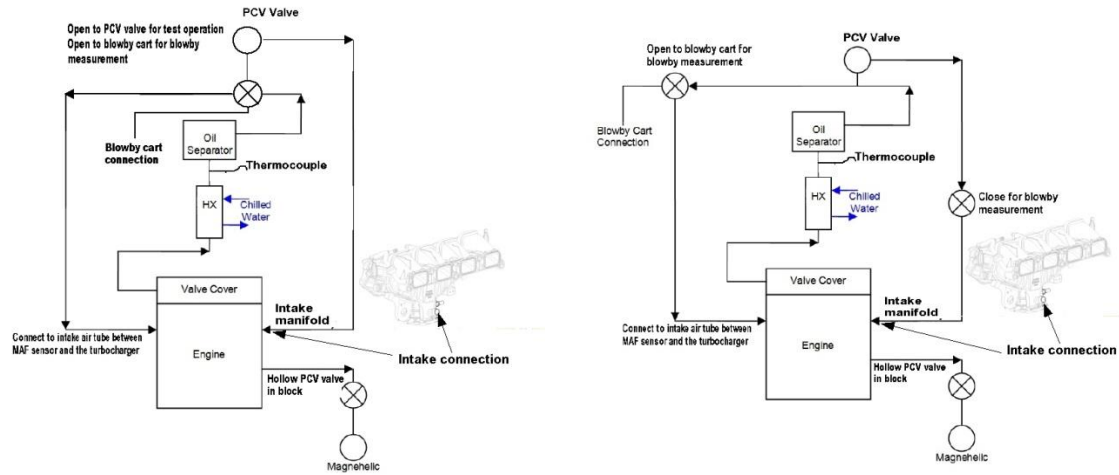

Figure A2.8: Exhaust Measurements and Instrumentation



3-way valve connection

2-way valve connection

Figure A2.9: Crankcase Ventilation System

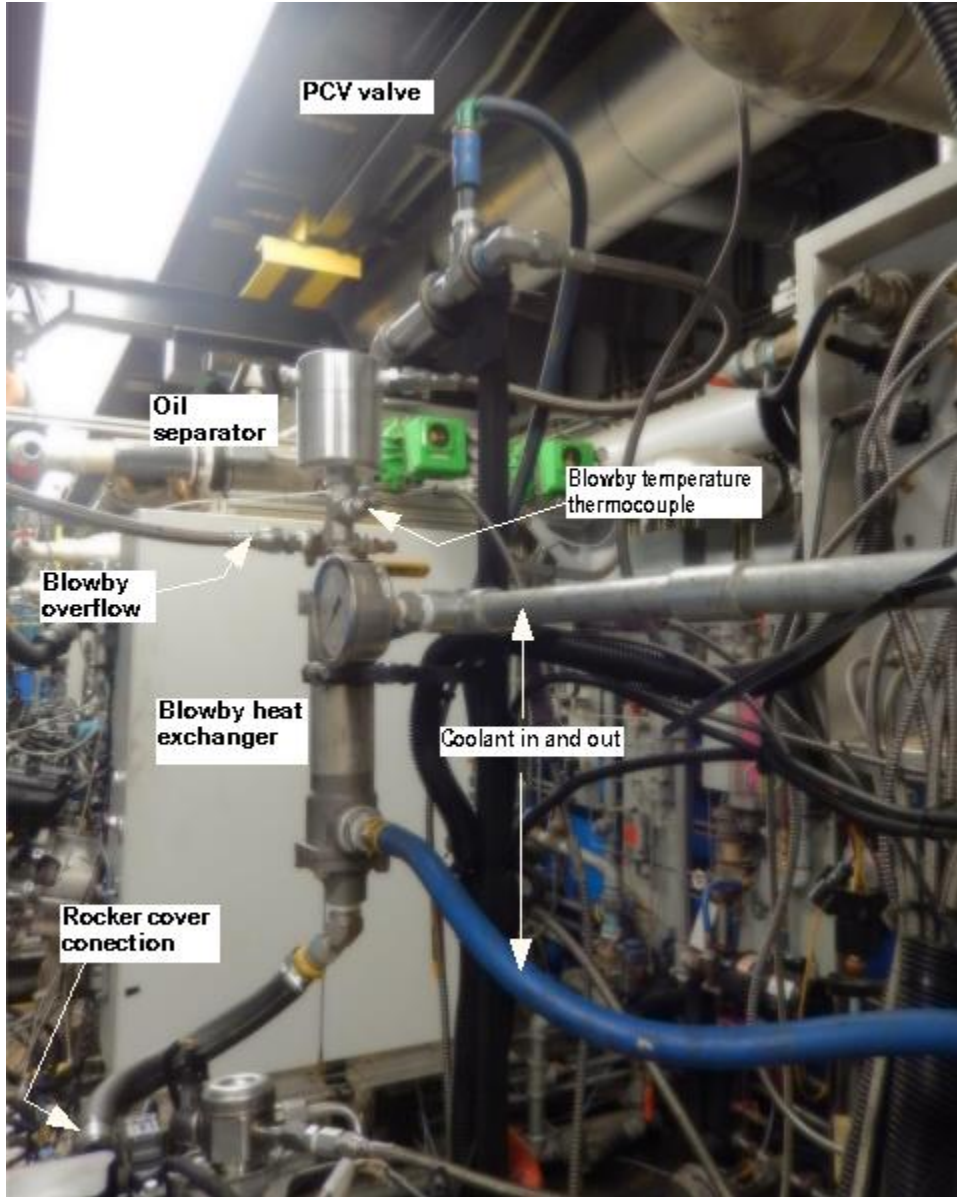
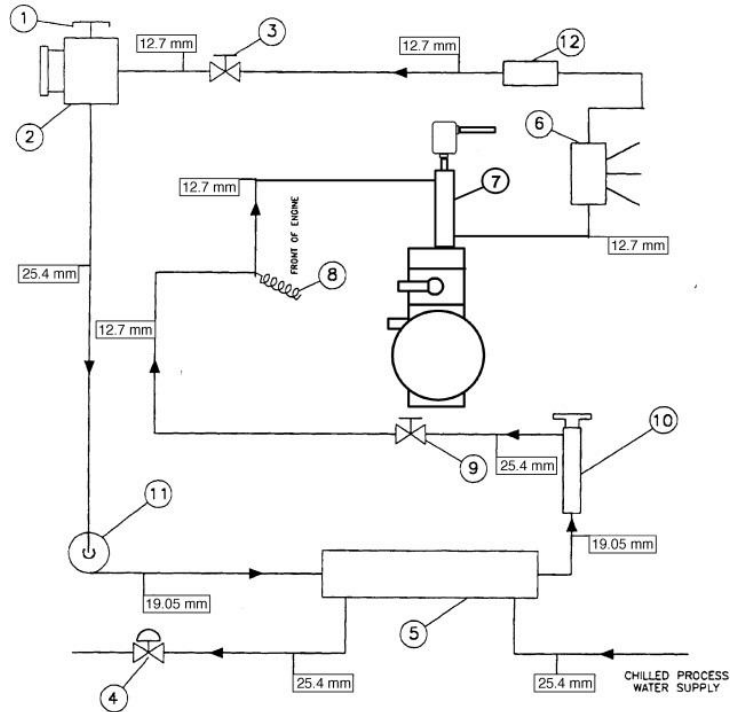

Figure A2.10: Crankcase Ventilation System



Legend

- (1) Vented reservoir cap
- (2) Coolant reservoir (fabricated)
- (3) Pressure control valve (optional)
- (4) Chilled process water control valve
- (5) System heat exchanger
- (6) F and P Co. flowrator tube, FF-1-35-G-10/448D053U06
- (7) CCV Heat Exchanger
- (8) Inlet temperature sensor
- (9) Flow control valve
- (10) External heat source
- (11) Electric coolant pump DAYTON 6K581A
- (12) ABB Kent-Taylor flow element, 1330LZ08000-8375A

FIG. 2.11 Typical CCV Heat Exchanger Heating and Cooling System

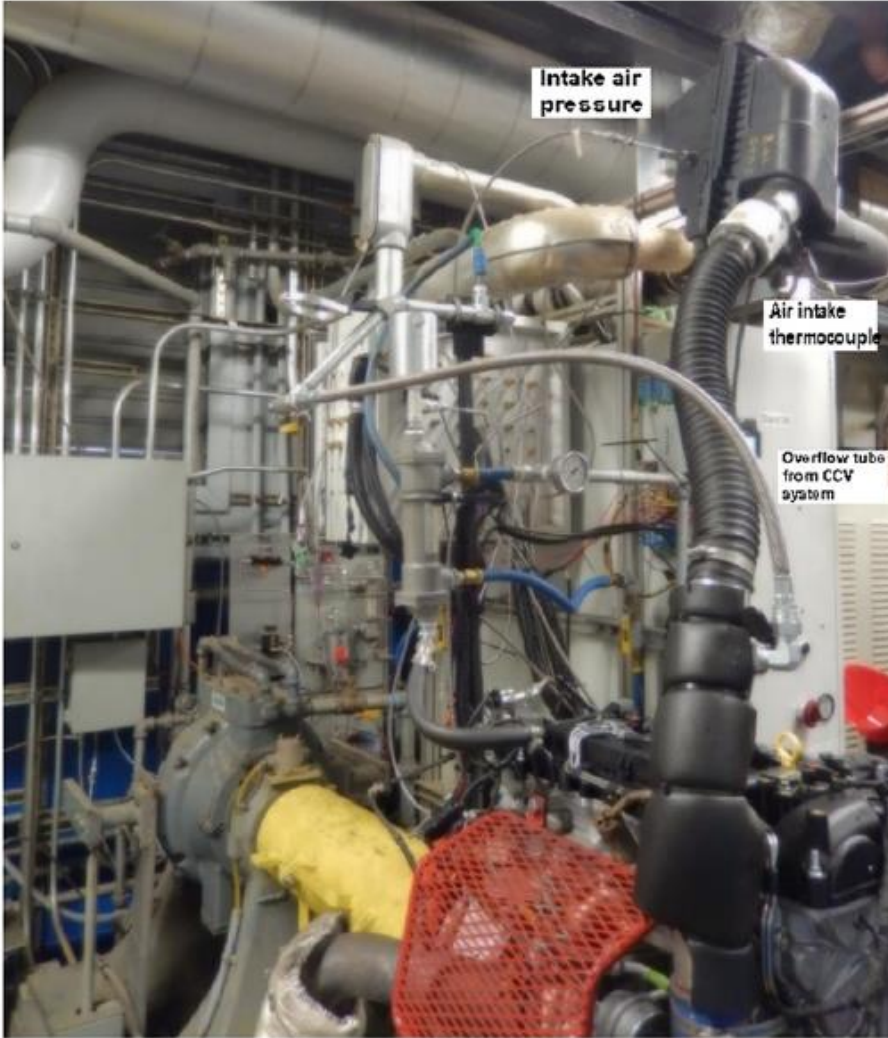

FIG. A2.12 Typical air intake system

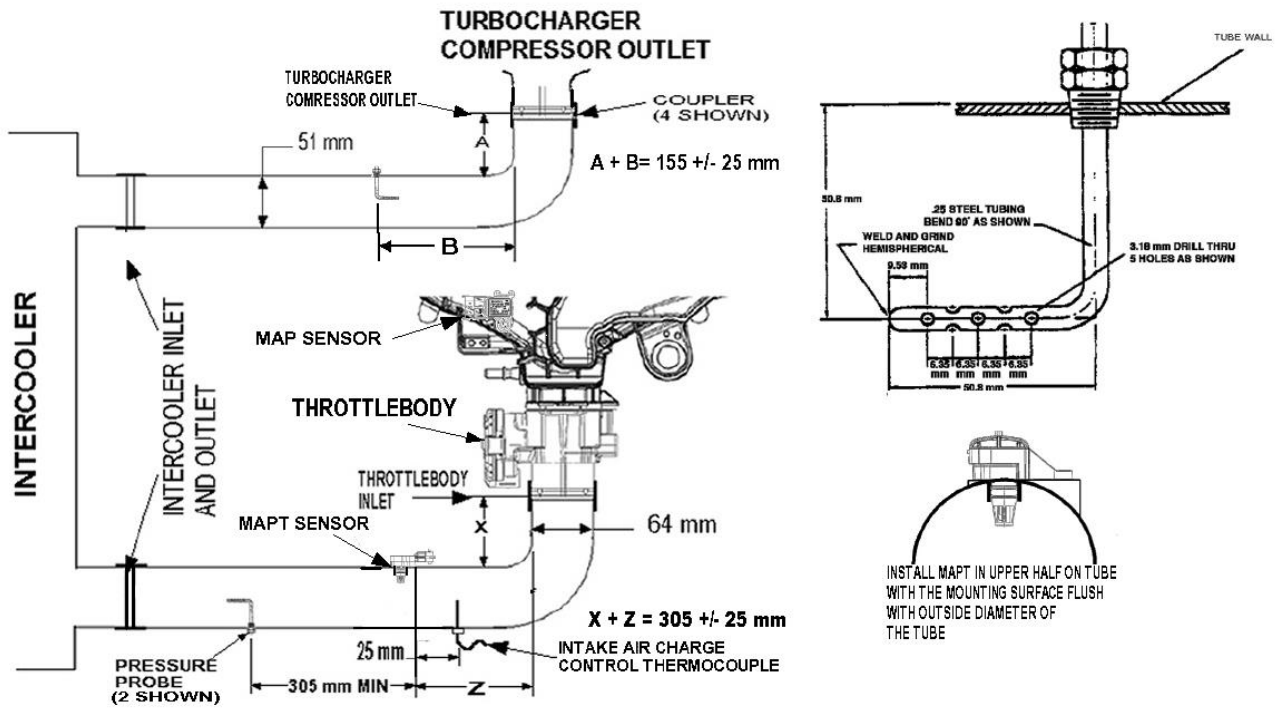

Figure A2.13: Intercooler Tubing Measurements and Instrumentation

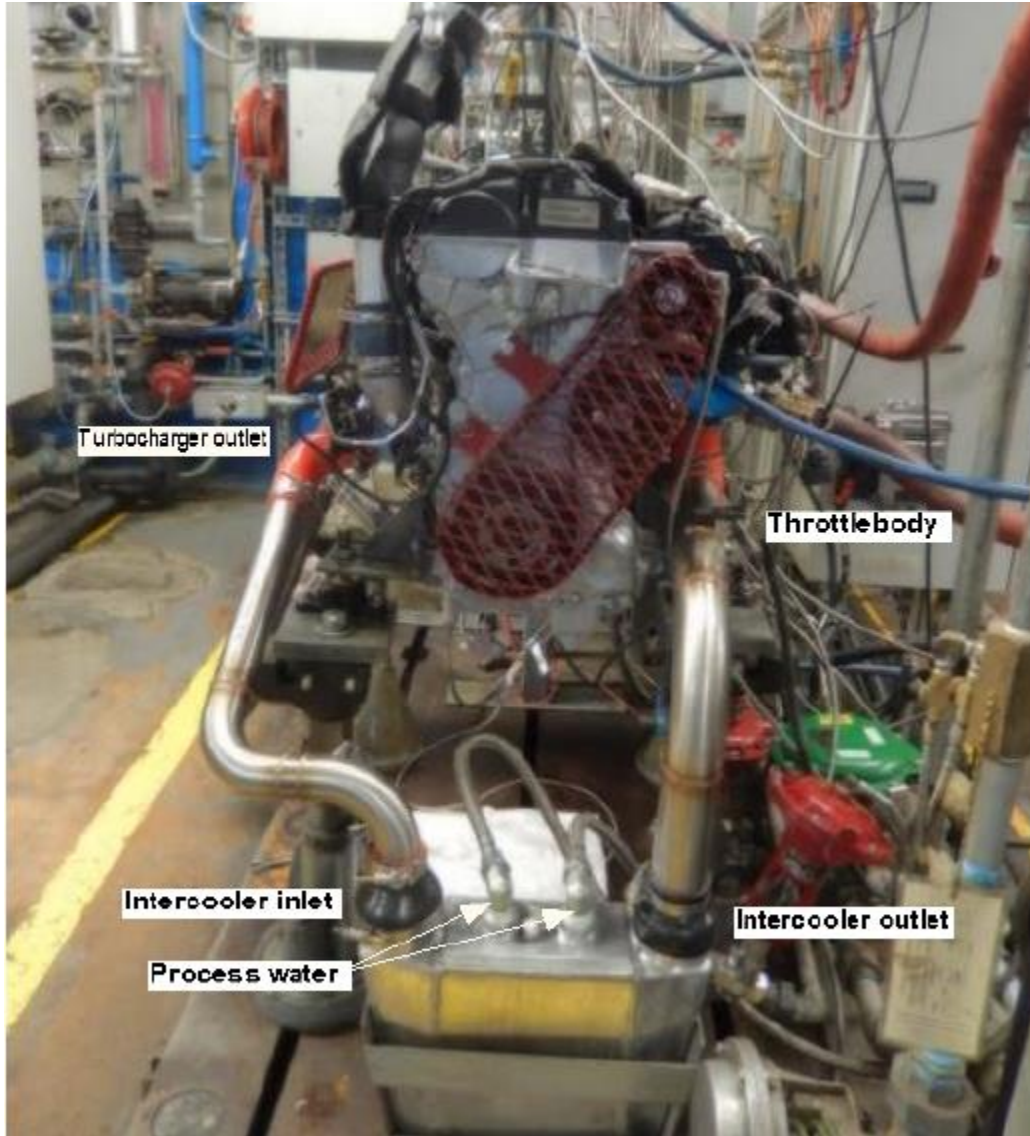

Figure A2.14 Typical intercooler installation



Figure A2.15 Oil cooler showing oil gallery pressure location

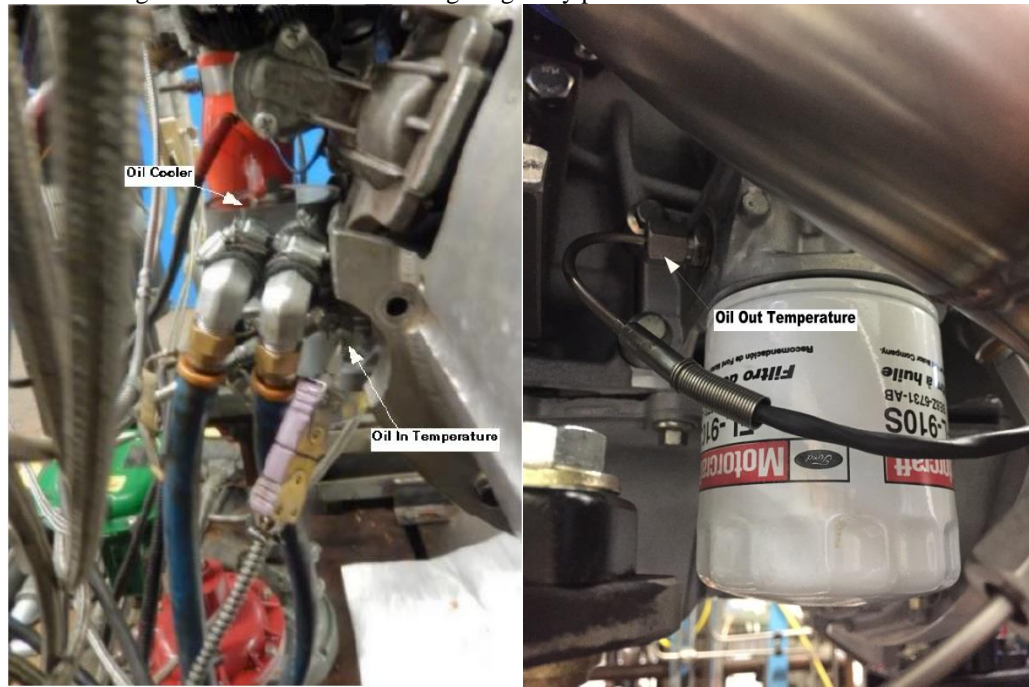

Figure A2.16 Oil cooler showing oil temperature locations

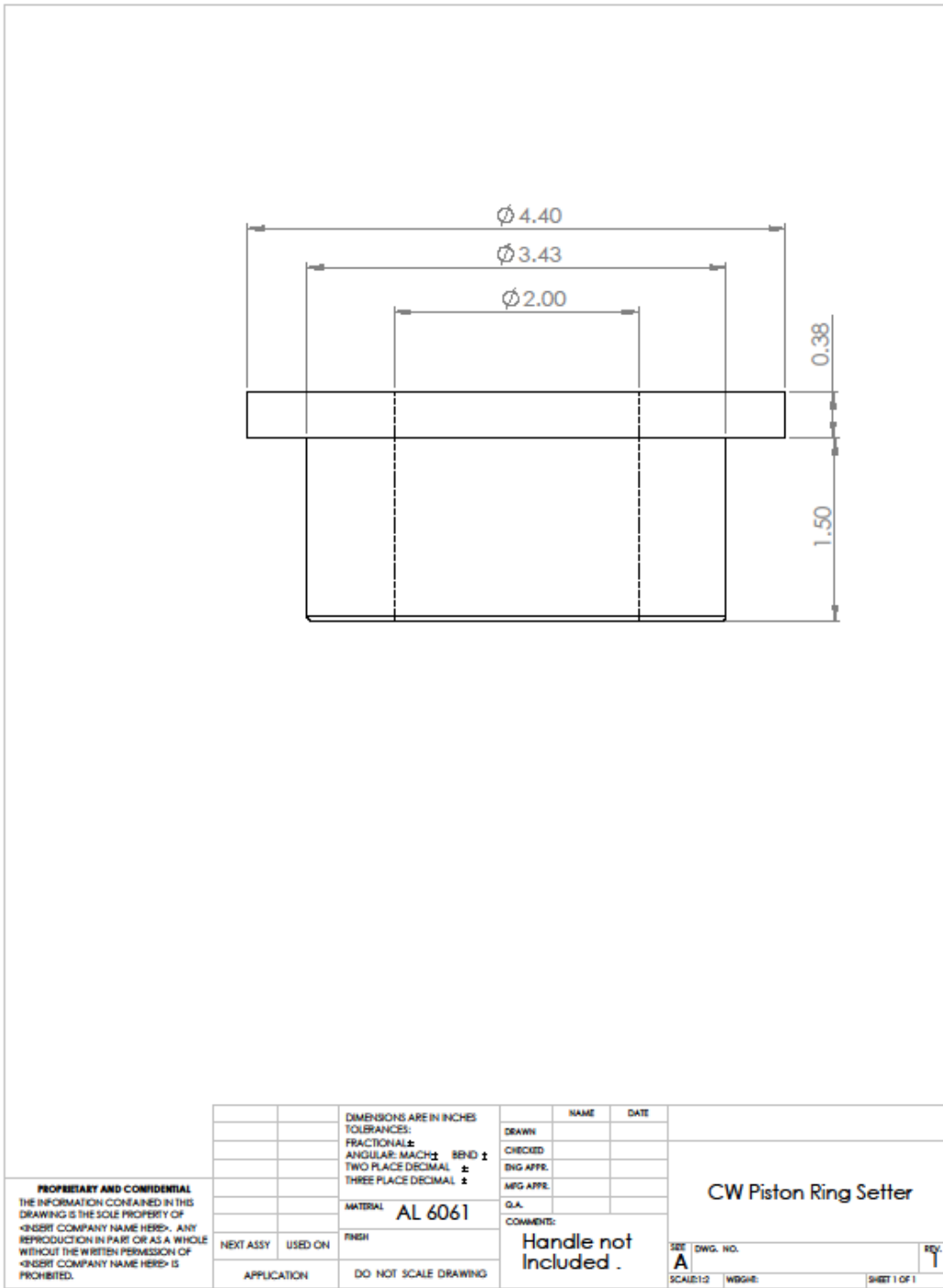
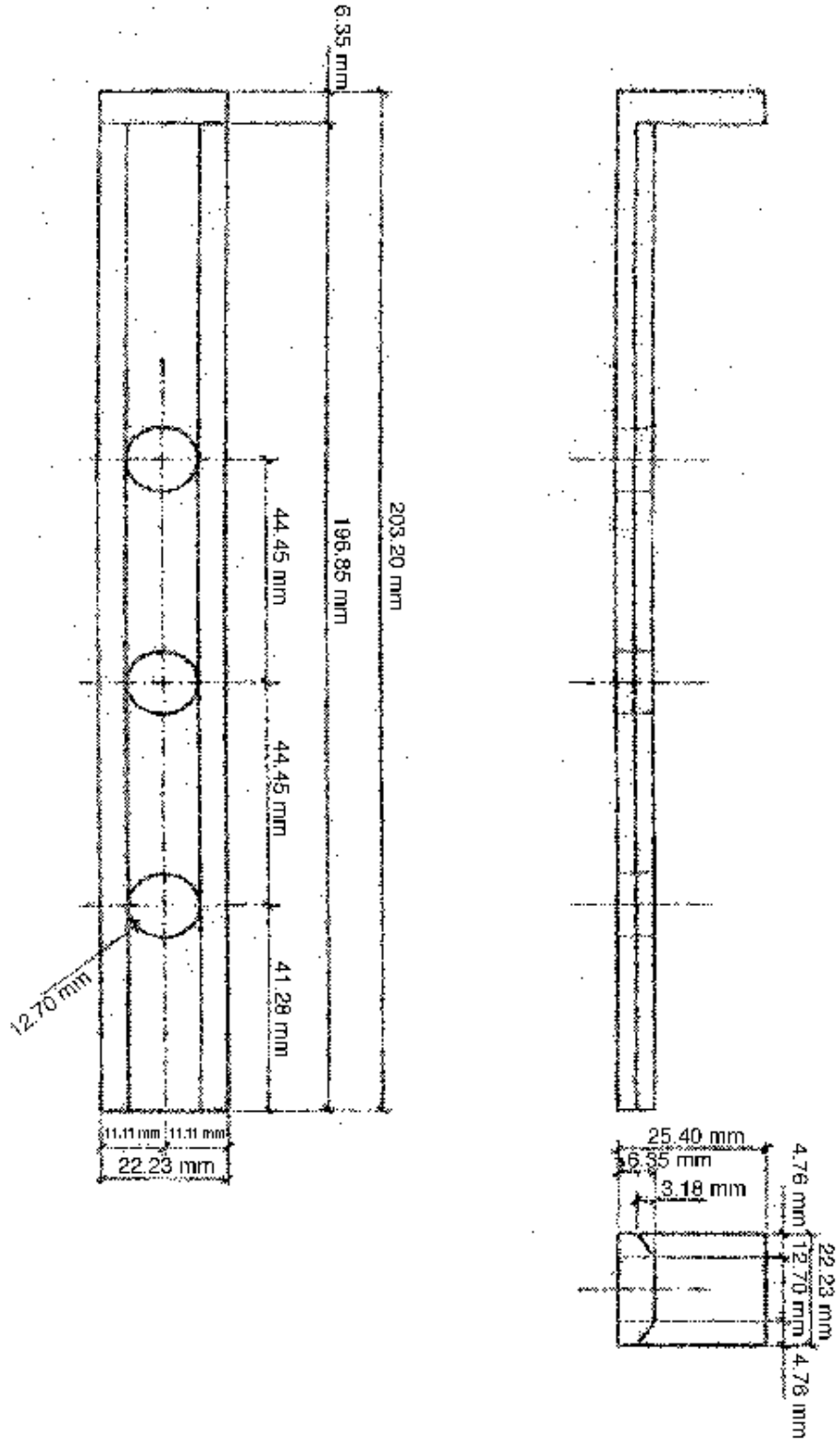
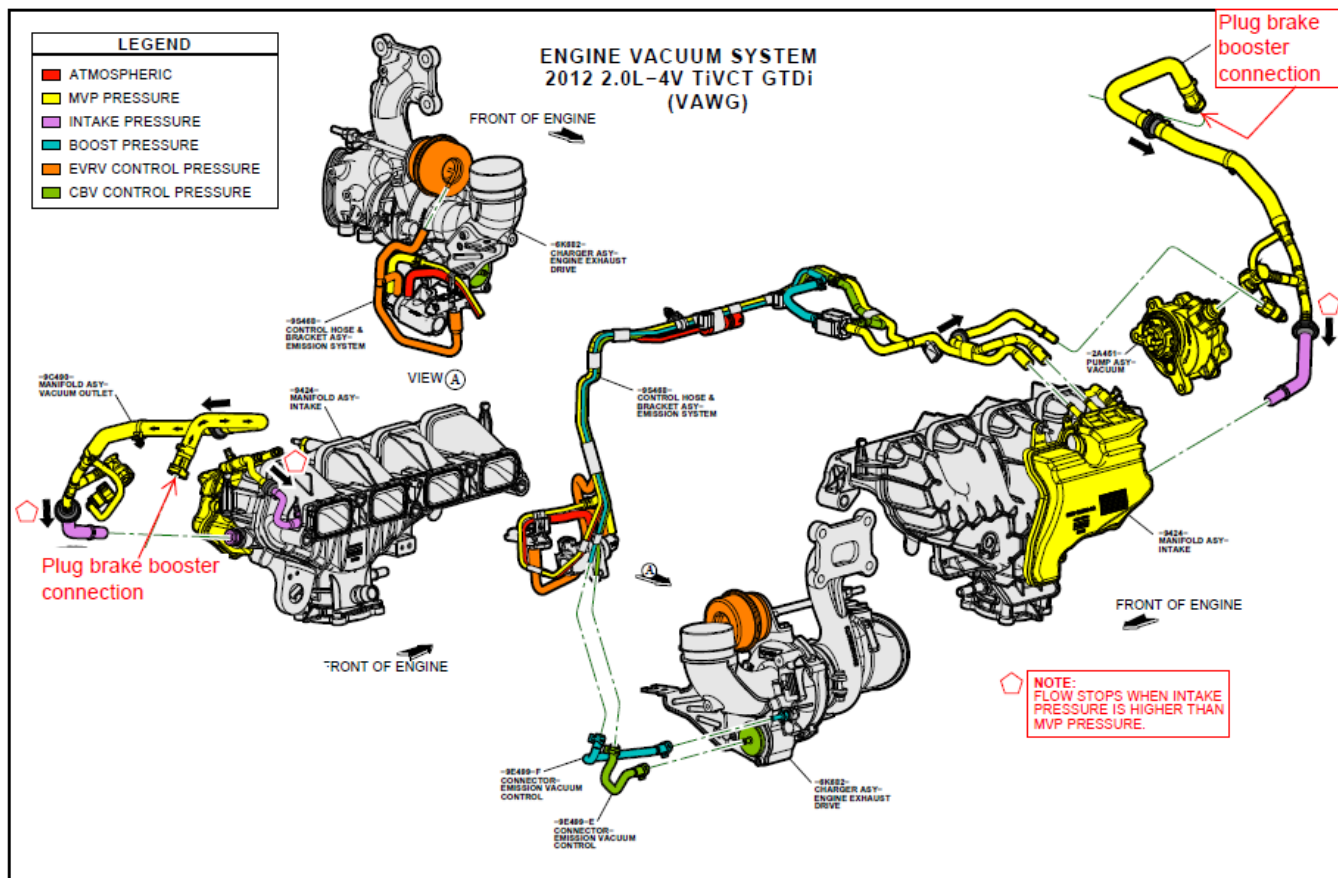

Figure A2.17



Bore Ladder
Figure A2.18



Vacuum System
Figure A2.19

Engine wire harness connections
Figure A2.20

Dynamometer wire harness connections
Figure A2.21

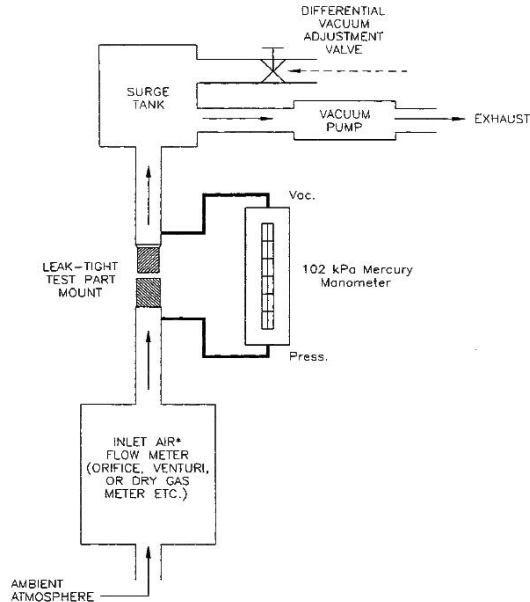

NOTE 1—The inlet flow meter must calibrate to within 5 % of the standard (pre-calibrated) orifices at the pressure differentials stamped on the orifices.

FIG. A2.22 PCV Valve Flow Test Apparatus

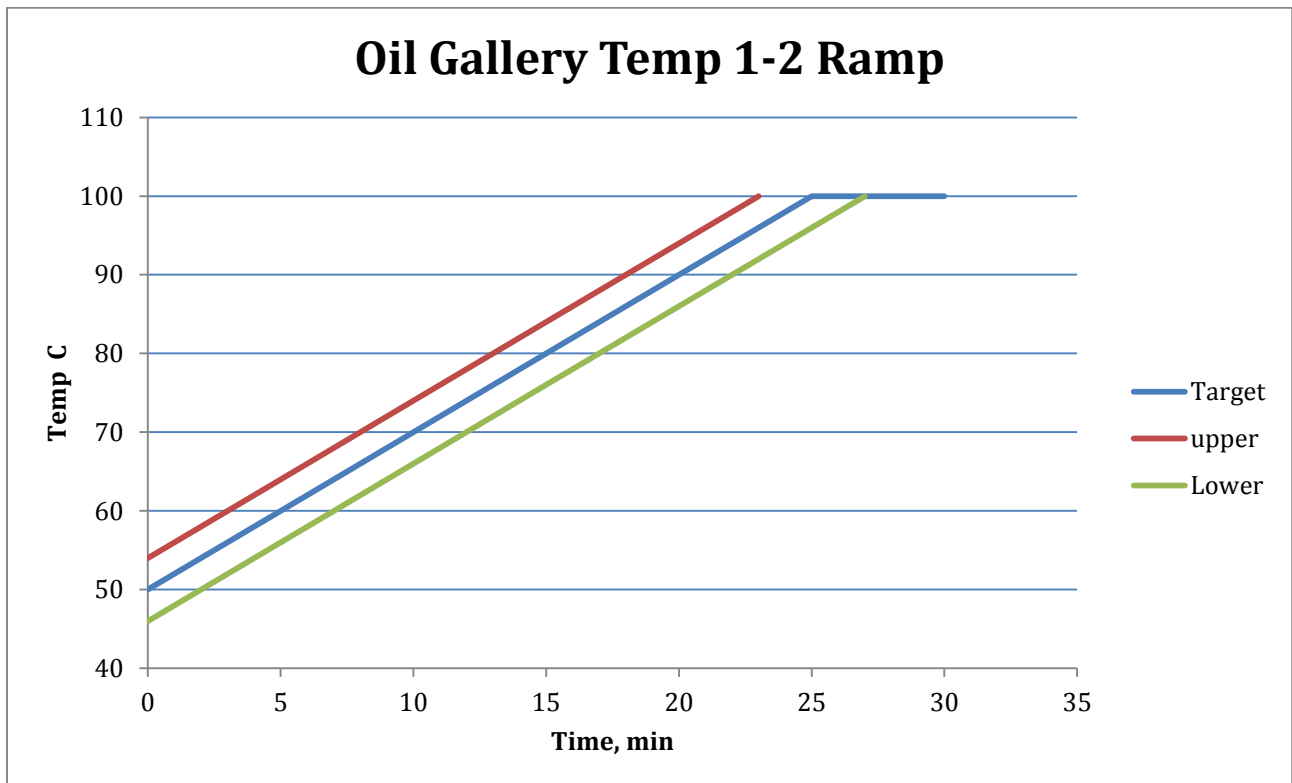

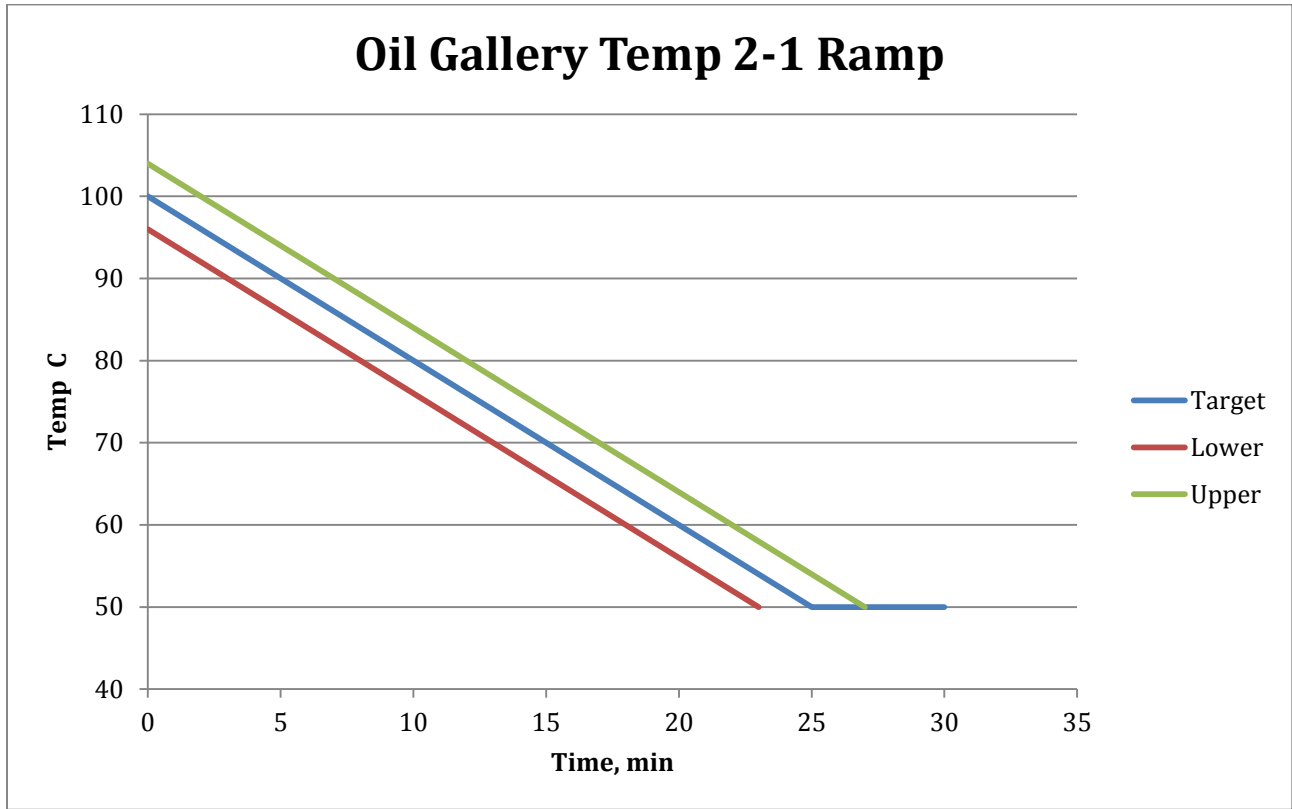

Typical Torque and temperature ramps
Figure A2.23

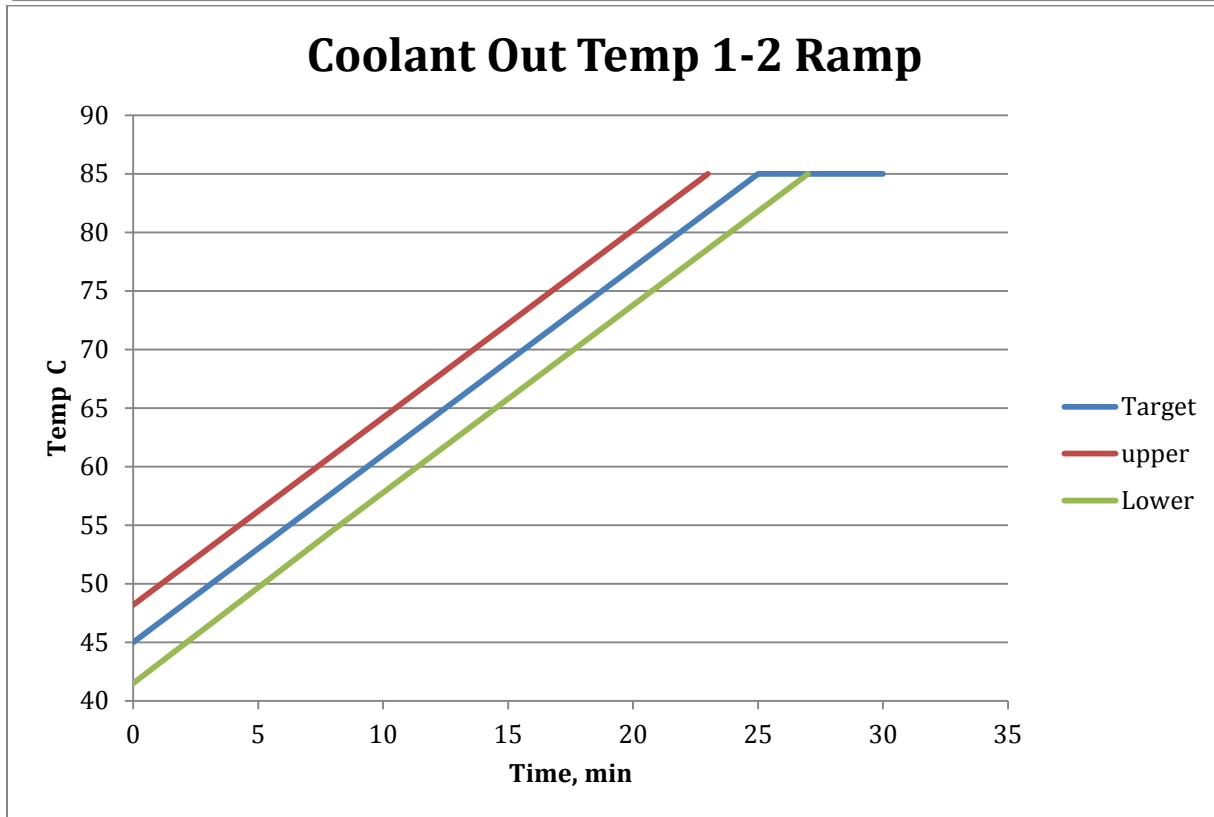
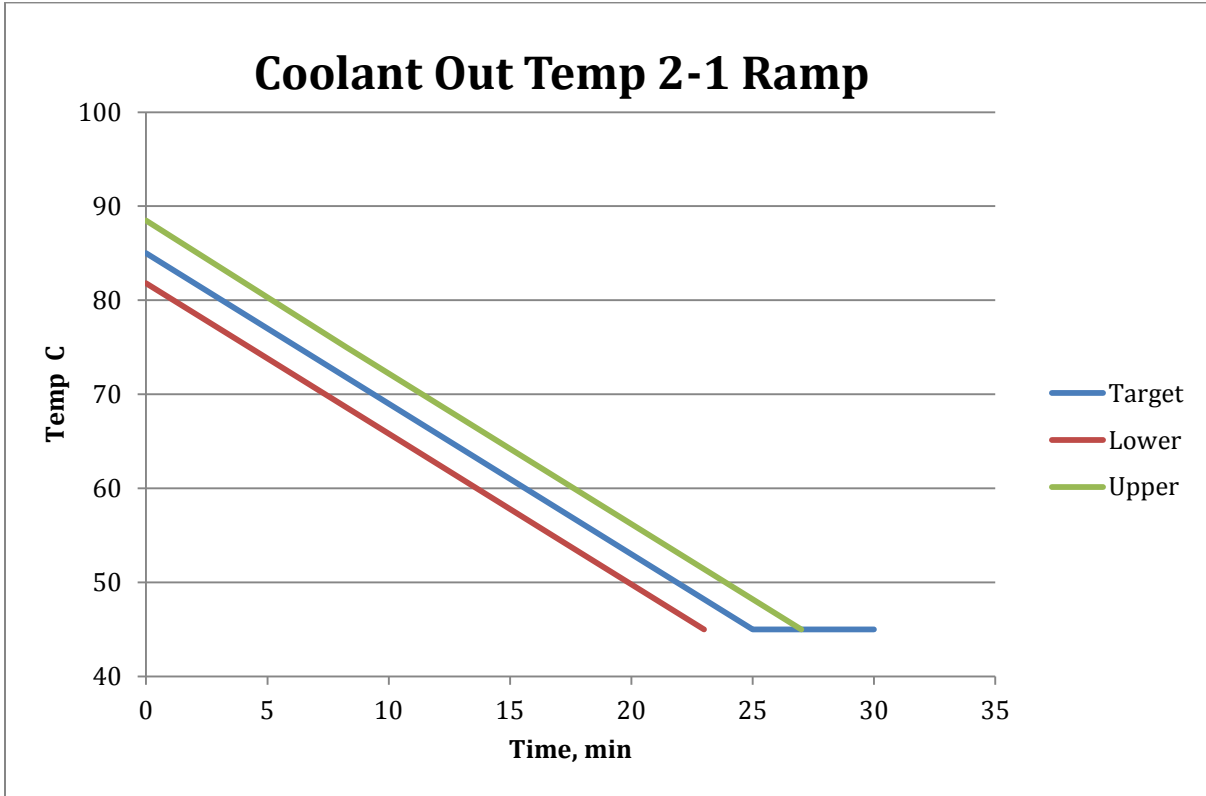

Typical Torque and temperature ramps
Figure A2.23 (cont)

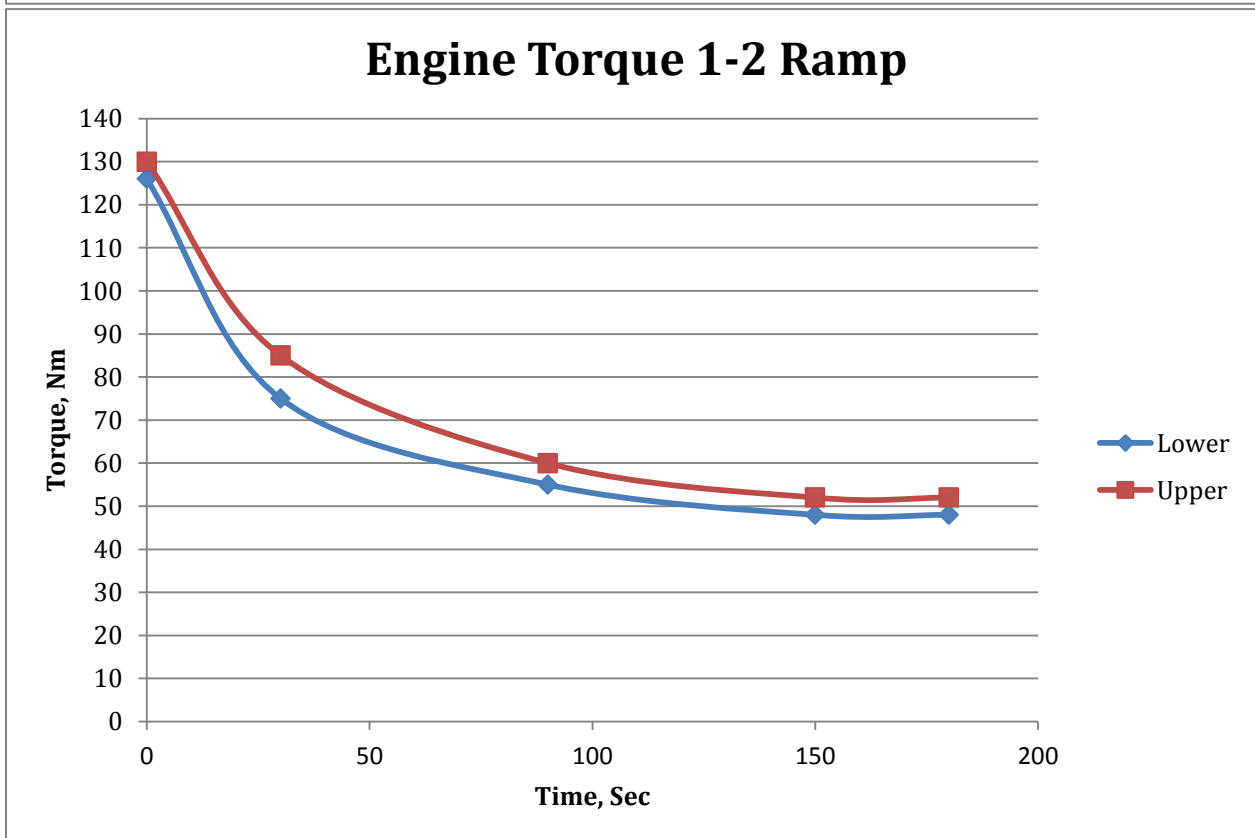
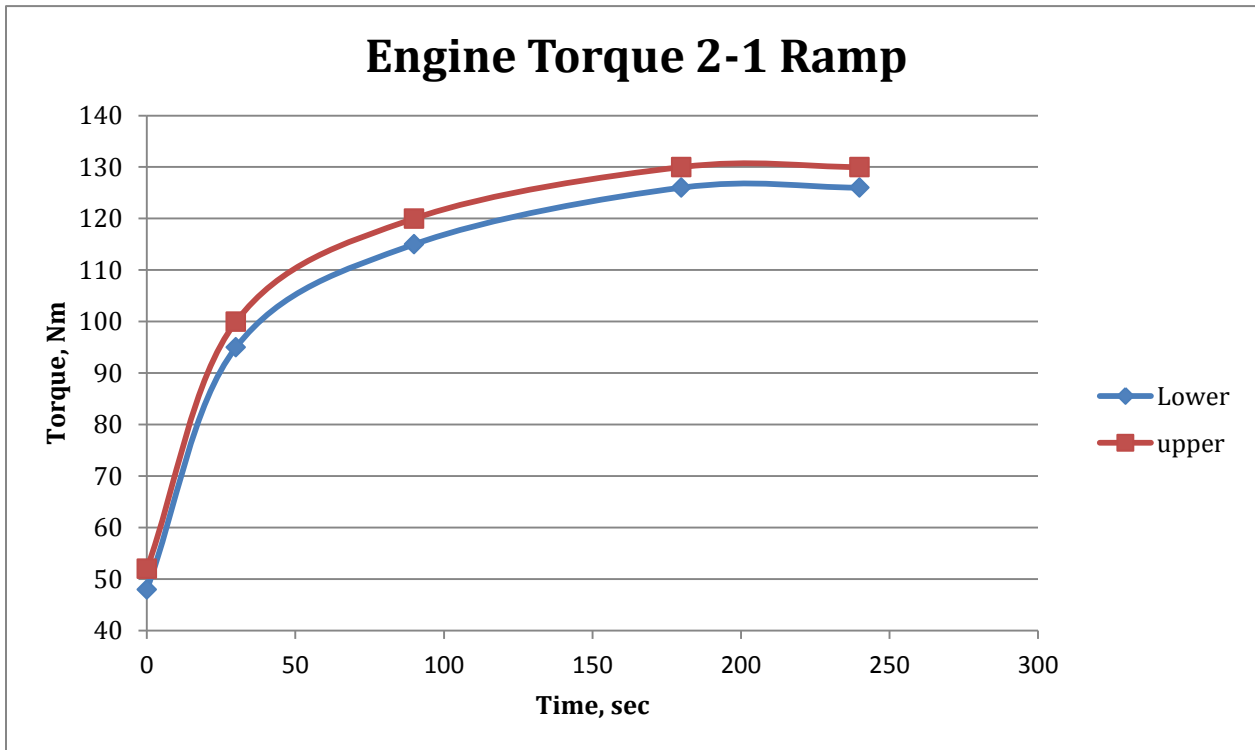

Typical Torque and temperature ramps
Figure A2.23 (cont)

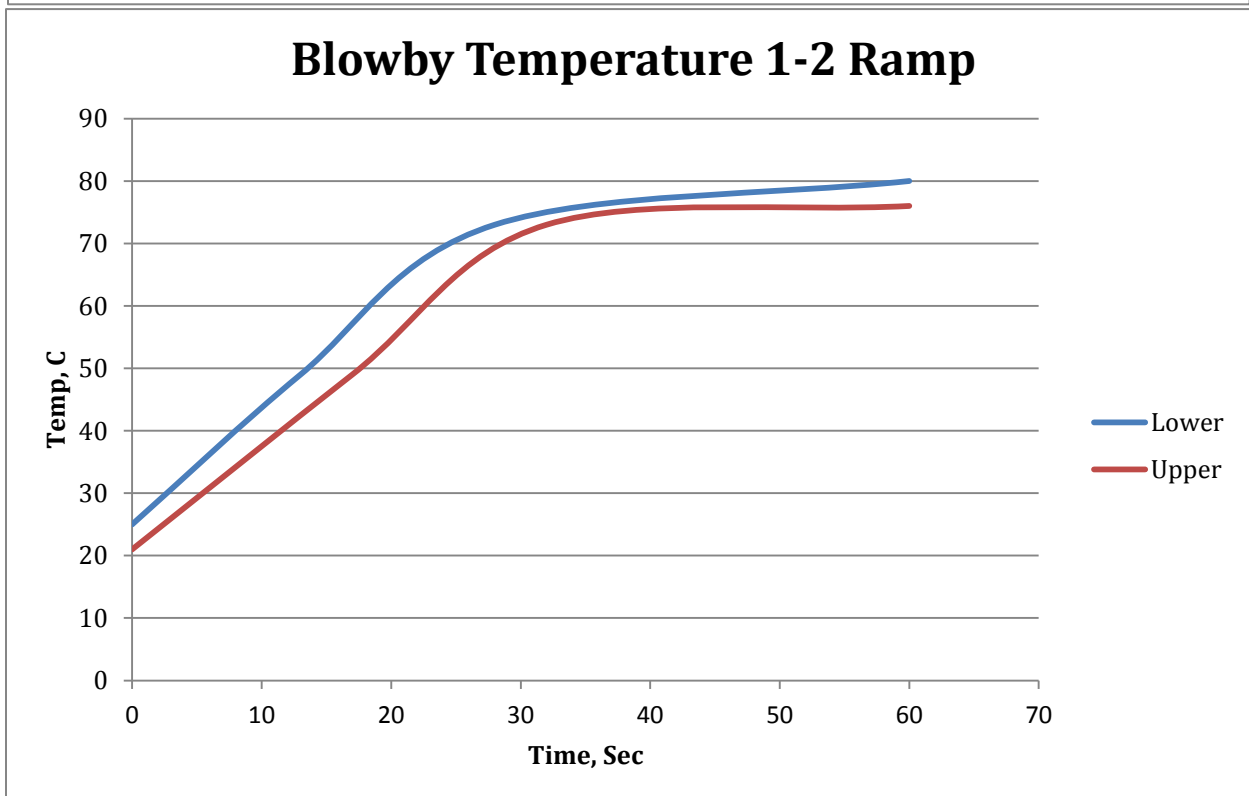
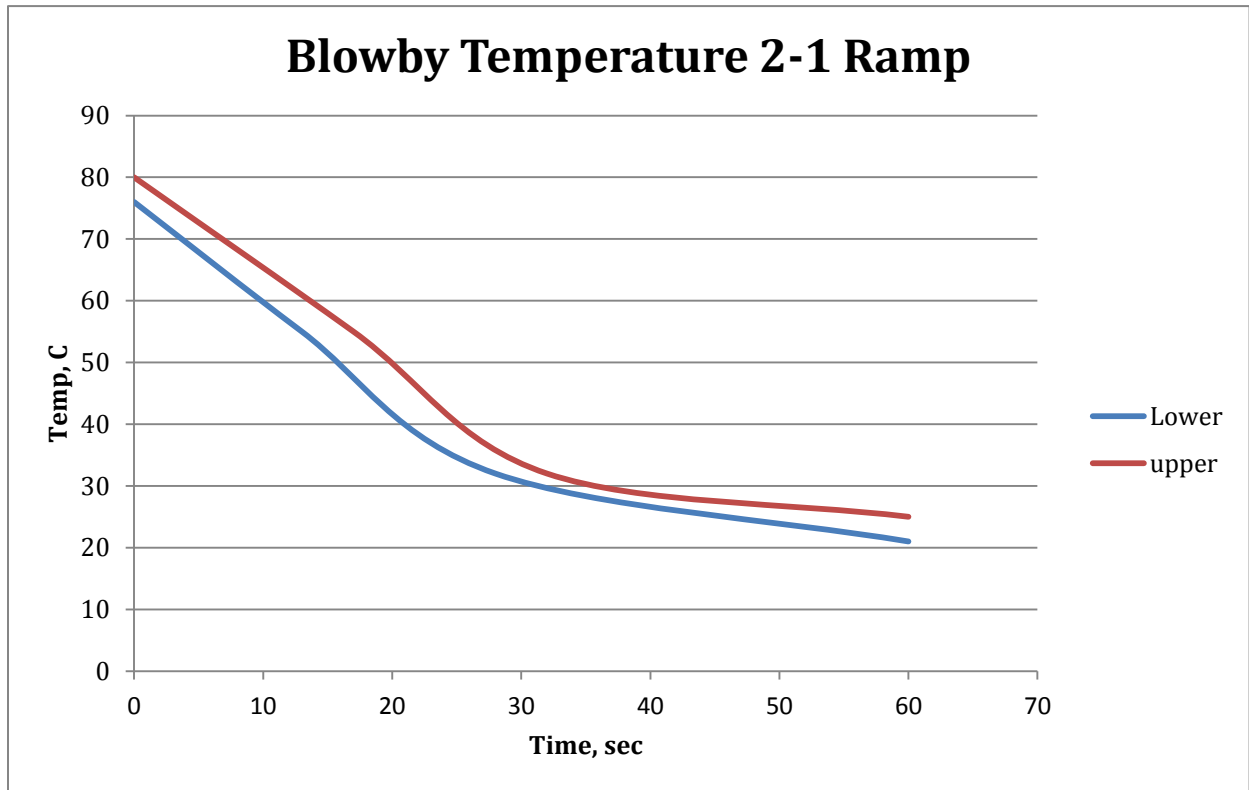

Typical Torque and temperature ramps
Figure A2.23 (cont)



CW HEAD DATA SHEET

HEAD # _____
 HEAD RUN # _____
 DATE: _____

Engine # _____
 Test # _____
 Instrument Cntrl # (Valve Guide) _____
 Instrument Cntrl # (Valve Stem) _____

	Valve Guide Diameter (5.51) mm	Valve Stem Diameter (5.5) mm	Clearance (0.03-0.07) mm
1A Intake			°.0
1B Intake			°.0
2A Intake			°.0
2B Intake			°.0
3A Intake			°.0
3B Intake			°.0
4A Intake			°.0
4B Intake			°.0

	Valve Guide Diameter (5.51) mm	Valve Stem Diameter (5.5) mm	Clearance (0.03-0.07) mm
1A Exhaust			°.0
1B Exhaust			°.0
2A Exhaust			°.0
2B Exhaust			°.0
3A Exhaust			°.0
3B Exhaust			°.0
4A Exhaust			°.0
4B Exhaust			°.0

Instrument Cntrl # (Length)

	SPRING FREE LENGTH (47mm)	SPRING TENSION (@28.5 mm)
1A Intake		Kilos
1B Intake		Kilos
2A Intake		Kilos
2B Intake		Kilos
3A Intake		Kilos
3B Intake		Kilos
4A Intake		Kilos
4B Intake		Kilos

Instrument Cntrl # (Tension)

	SPRING FREE LENGTH (47mm)	SPRING TENSION (@28.5 mm)
1A Exhaust		Kilos
1B Exhaust		Kilos
2A Exhaust		Kilos
2B Exhaust		Kilos
3A Exhaust		Kilos
3B Exhaust		Kilos
4A Exhaust		Kilos
4B Exhaust		Kilos

Instrument Cntrl # (Lash)

Intake Valve Lash Measurement (.19 - .31) mm	
1F	
1R	
2F	
2R	
3F	
3R	
4F	
4R	

Exhaust Valve Lash Measurement (.30 - .42) mm	
1F	
1R	
2F	
2R	
3F	
3R	
4F	
4R	

Head Flatness: _____

Initials: _____

Cylinder Head Build Data Sheet
Figure A2.24



CW Cylinder Bore Measurement Record

Block # / Run # : _____ / _____
Test Number: _____

Date: _____
Tech: _____

Cylinder Bore Measurements w/o Stress Plate

Finish Target: (9- 13 Ra) μ in
Bore Gauge Set: 87.5 mm

Piston to Wall Clearance: (.0225 - .0475) mm
Cylinder Cross HatchTarget: (25°-35°) Deg

Instrument Cntrl

Cylinder Number	Location	Longitudinal Diameter (mm)	Transverse Diameter (mm)
1	Top	87	87
	Middle	87	87
	Bottom	87	87
2	Top	87	87
	Middle	87	87
	Bottom	87	87
3	Top	87	87
	Middle	87	87
	Bottom	87	87
4	Top	87	87
	Middle	87	87
	Bottom	87	87

Instrument Cntrl

Surface Finish (μ in)	Piston Diameter (mm)	Piston Clearance (mm)
87	87	87
87	87	87
87	87	87
87	87	87
87	87	87
87	87	87
87	87	87
87	87	87
87	87	87
87	87	87

Instrument Cntrl

Cylinder Number	Top Ring Gap	Second Ring Gap
1		
2		
3		
4		

REGAP/EOT

Cylinder Number	Top Ring Gap	Second Ring Gap
1		
2		
3		
4		

Approved _____

Cylinder Bore Measurement Record
Figure A2.25



CW Engine Measurement Record

Engine Number: _____ Date: _____

Test Number: _____ Technician: _____

Instrument Cntrl # (Journal) _____ Instrument Cntrl # (Bearing) _____

Main Bearing Journals (mm)				
<i>Diameter: (51.978mm - 52.002mm)</i>				
Journal Number	Horizontal Diameter	Vertical Diameter	Bearing Inside Diameter	Clearance .027mm - .052mm
1				
2				
3				
4				
5				

Instrument Cntrl # (Journal) _____ Instrument Cntrl # (Bearing) _____

Rod Bearing Journals (mm)				
<i>Diameter: (51.978mm - 52.002mm)</i>				
Journal Number	Horizontal Diameter	Vertical Diameter	Bearing Inside Diameter	Clearance .027mm - .052mm
1				
2				
3				
4				

Instrument Cntrl # (Endplay) _____

Crankshaft End Play (0.22 mm - 0.45 mm) _____

Engine Bearing Measurement Record
Figure A2.26

A3. CONTROL AND DATA ACQUISITION REQUIREMENTS

A2.1 General Description:

A2.1.1 The data acquisition system shall be capable of logging the operational data in digital format. It is to the advantage of the laboratory that the system be capable of real time plotting of controlled parameters to help assess test validity. The systems shall be capable of calculating real time quality index as this will be monitored throughout the test as designated in A2.5.

A2.1.2 Control capability is not dictated by this procedure. The control system shall be capable of keeping the controlled parameters within the limits specified in Table 4 (see 12.2.3) and maintain the quality index shown in A2.5.

A2.1.3 Design the control and data acquisition system to meet the requirements listed below. Use the recommendations laid out in the Instrumentation Task Force Report and Data Acquisition Task Force Report for any items not addressed in Annex A2.

A2.2 Digital Recording Frequency—The maximum allowable time period over which data can be accumulated is one second. This data can be filtered, as described in A2.6, and will be considered a reading.

A2.3 Steady State Operation:

A2.3.1 This portion of the test will be the entire time at Stage 1 and 2 conditions. Stage 1 and 2 conditions are reached by the end of the ramping periods. Calculate the quality index using values reported to the accuracy levels in Table A2.1.

TABLE A2.1 Accuracy Levels of Data Points to be Used in QI Calculations

Parameter	Field Length
Speed	
Humidity	
Temperature	
Torque	
Intake Air Pressure	
Exhaust Backpressure	
Coolant Outlet Pressure	
Coolant Flow	

TABLE A2.2 L and U Constants and Over and Under-Range Values

Parameter	Stages	L	U	Over-Range	Under-Range
Coolflow	1				
Cooloutt	1				
	2				
Exhbprs	1				
	2				
Humidity	1, 2				
Intairpr	1, 2				
Intairt	1, 2				
Oilint	1				
	2				
Speed	1				
	3				
Torque	1				
	2				
Cooloutp	1, 2				
BBint	1				
	2				

**TABLE A2.3 Maximum Allowable Time Constants**

Control Parameter	Time Constant, s
Engine speed, r/min	1.9
Torque, Nm	1.8
Engine oil in, °C	2.4
Engine coolant out, °C	2.4
Engine coolant flow, L/min	17.0
Blowby in, °C	2.4
Intake, air, °C	2.4
Intake air press, kPa	2.6
Exhaust back pressure, kPa	1.7
Engine coolant pressure	2.0

A2.3.2 The time intervals between recorded readings shall not exceed 1 min. Data shall be recorded throughout the length of each stage.

A2.4 Transitions :

A2.4.1 The ramp requirements are listed in 12.2.3.3, Table 5.

A2.4.2 During the transition, the time intervals between all recorded readings shall not exceed 2 seconds..

A2.5 Quality Index:

TBD

A2.6 Time Constants:

A2.6.1 Filtering can be applied to all control parameters. The amount of filtering applied shall not allow time constants to exceed the values listed in Table A2.3. This time constant shall pertain to the entire system, running from the sensor to the display and data acquisition.

A2.6.2 Maximum allowable system time constants for the controlled parameters are shown in Table A2.3

A9.1 Test Engine Parts—The required parts for use in the Chain wear test procedure are for the 2.0L GTDI engine which are supplied by the test sponsor (Ford Motor Company) through Ford Component Sales:

Ford Motor Co.

290 Town Center Dr

Dearborn, MI 48126

A9.2 Various Materials—

Oil pan and baffles,

Oil screen,

Flywheel

Clutch, pressureplate, spacer, bellhousing

Dynamometer and engine wire harnesses

Are available from the following supplier:

OH Technologies

9300 Progress Pkwy.

Mentor, OH 44060

A9.3 Various Materials—

Are available from the following supplier:

Test Engineering, Inc.

12758 Cimarron Path, Ste. 102

San Antonio, TX 78249-3417

A9.4 Test engine Parts –

A9.4 Oil separator
Moroso Part number 85487
Are available from the following supplier:
American Muscle
Summit Racing

A9.5 Type 5 or Type 52 intercooler from www.frozenboost.com

A9.6 Chain Measurement Apparatus can be obtained from George.

A9.8 Powertrain Control Module are available from the following supplier:

Annex X

X1. PISTON AND RING MEASUREMENTS RECORD FORMS

X1.1 The necessary engine measurement record forms are shown in Figs. X1.1-X1.3.

X2. SOURCES OF MATERIALS AND INFORMATION

X2.1 The following sources are provided for convenience only. This does not represent an exclusive or complete listing of required materials or information sources.

X2.1.1 Test Engine Parts— Chain wear test parts can be purchased through Ford Component Sales and Ford or Lincoln dealers:

Ford Motor Co.
290 Town Center Dr
Dearborn, MI 48126

X2.1.2 ASTM Test Monitoring Center—All communications with the TMC should be directed as follows:

ASTM Test Monitoring Center
6555 Penn Ave.
Pittsburgh, PA 15206-4489

X2.1.3 Test Sponsor—All communications with the test sponsor (Ford Motor Co.) should be directed as follows:

Ford Motor Company
Diagnostic Service Center II
1800 Fairlane Drive,
Room 410
Allen Park, MI 48101

X2.1.4 Aeroquip Hose and Fittings—Aeroquip hose and fittings can be obtained from the following supplier:

Aeroquip Corp.
1225 W. Main
Van Wert, OH 45891

X2.1.5 Fuel Information and Availability—General information concerning EEE fuel, including availability, can be obtained from the following:

Haltermann Products
1201 S. Sheldon Rd.
P.O. Box 249
Channelview, TX 79530-0429

X2.1.7 Intake-Air Humidity Instruments—The Alnor Dewpointer, EG & G, Foxboro, Hy-Cal, General Eastern and Protimeter dewpoint meters are suitable for measurement of the intake-air specific humidity.

X2.1.9 Heat Exchangers—ITT Standard Heat Exchangers can be obtained from the following supplier:
Kinetics Engineering Corp.
2055 Silber Road, Suite 101
Houston, TX 77055

X2.1.10 Fuel Flow Measurement—Mass fuel flowmeters are available from the following supplier:
Micro Motion Corp.
7070 Winchester Circle
Boulder, CO 80301

X2.1.12 Parts Washer and Chemicals—A dishwasher type parts cleaner and associated chemicals can be obtained from the following supplier:
Better Engineering Manufacturing
8361 Town Court Center
Baltimore, MD 21236-4964

X2.1.13 Crankcase and Intake—Air Pressure Gages—Gages are available from the following supplier:
Dwyer Instrument Co.
Junction of Indiana State Highway 212 and U.S. Highway 12
P.O. Box 373
Michigan City, IN 46360

X2.1.14 Blowby Heat Exchanger Coolant—Nacool 2000 Engine Cooling System Treatment is available from the following supplier:
Nalco Chemical Co. Functional Chemicals Group
One Nalco Ctr.
Naperville, IL 60566-1024

X2.1.15 Lubricants—EF-411 is available from local distributors of ExxonMobil products.

X2.1.16 Tygon Hose—Tygon hose is available through local Cadillac Plastic Co. distributors or the following supplier:
The Norton Co.
12 East Avenue
Tallmadge, OH 44278

X2.1.17 Special Tools for the Test Engine—Special tools to facilitate assembly and disassembly of the engine are available from the following supplier:
Owatonna Tool Co.
2013 4th St.
NW Owatonna, MN 55060

X2.1.18; : Tierra Tech model MOT500NS ultrasonic parts cleaner or similar Tierra Tech ultrasonic parts cleaner can be obtained from Tierra Tech

X2.1.19: Tierra Tech Ultrasonic solution 7 and B cleaner can be obtained from Tierra Tech

X2.1.20: Flex Hone Model: GB33432 can be obtained from Granger

X2.1.21: Pneumatic Honing Drill, Westward 1/2 Reversible Air Drill, Model: 5ZL26G can be obtained from Granger

X2.1.22: Penmul L460 can be obtained from Penetone Corp., P.O. Box 22006, Los Angeles, CA 90022

X2.1.23: Parts Cleaning Soap, (NAT-50 or PDN-50) known to the committee at this time is Better Engineering Manufacturing, 8361 Town Court, Baltimore, MD 21236.

X2.1.24: Hatchview Software (<http://digitalmetrology.myshopify.com/products/hatchview>)

X2.1.25: USB microscope.

X2.1.26: The sole source of supply of the Sanford Piston Ring Grinder known to the committee at this time is Sanford Mfg. Co., 300 Cox St., P.O. Box 318, Roselle, NJ 07203.

- X2.1.27: The sole source of supply of the 3/16 in. carbide ring cutting burr, No. 74010020 known to the committee at this time is M. A. Ford.
- X2.1.28: The sole source of supply of Sunnen soft stone, No. JHU-820 known to the committee at this time is Sunnen, Inc., 7910 Manchester, St. Louis, MO 63143.
- X2.1.29: Ford camshaft alignment tool (Ford P/N 303-1565) can be obtained from a Ford or Lincoln dealer
- X2.1.30: Crankshaft TDC timing peg (Ford P/N 303-507)
- X2.1.31: CFM Balance Shaft Delete Kit (Part number 1-0180).
- X2.1.32 X2.1.33: Quicksilver part# 6628-A
- X2.1.34: Chemtool B12

12. Test Procedure

12.1 Pre-test Procedure:

12.1.1 *Engine Break-In Procedure*—Run break-in schedule listed in **Table 2**. Conduct the break-in before each test using the supplied test oil. The break in procedure has 12 steps and is 8.25hrs long. There are 30 second ramps between steps that are counted as part of the 8.25hrs. The engine is flushed during the break-in procedure. There are a total of 3 oil flushes as shown in **Table 2**; the oil is drained for 15 minutes after each flush.

12.1.1.1 A pre-measured timing chain should be installed in the engine as listed in section **7.11 Chain and Camshaft Installation Procedure**. The timing chain should have been coated in EF-411 oil before break-in installation as listed in section **7.9.5 Chain and Camshaft Installation Procedure**.

12.1.1.2 Charge the engine with 3600 grams of test oil. Prime and install a new oil filter. The engine is now ready to start Step 1 of the break in as listed in **Table 2**.

TABLE 2 Sequence CW Break-in Schedule

Step	Speed (RPM)	Load (N-m)	Time per stage (Hr:Min)	Total Time (Hr:Min)
Charge engine with 3600 grams of new test oil and new oil filter				
1	Idle	0	0:30	0:30



Oil Flush 1 -Shut engine down and drain used test oil and remove oil filter. Add 3600 grams of new test oil and install new oil filter				
Start engine and let idle for 5 minutes				
2	1500	38	0:30	1:00
3	2000	72	0:30	1:30
4	2500	111	0:30	2:00
5	3000	135	0:30	2:30
6	3000	150	3:15	5:45
7	2000	72	0:15	6:00
8	3250	155	0:15	6:15
9	3500	155	0:15	6:30
10	3750	155	0:15	6:45
11	4000	155	1:15	8:00
Bring engine to idle for 5 minutes and shut down.				
Oil Flush 2- Shut engine down and drain used test oil and remove oil filter. Add 3600 grams of new test oil and install new oil filter.				
12	Idle	0	0:15	8:15
Oil Flush 3- Shut engine down and drain used test oil and remove oil filter.				

12.1.1.3 The controlled parameters during break in are listed in [Table 3](#). All other controls are left wide open/free flowing. The engine does not produce enough heat in the early steps to reach all target temperatures. All controlled parameters are expected to be on target at the beginning of Step 4.

TABLE 3 Sequence CW Break-in Controlled Parameters

Break In Controlled Parameters	
Coolant Out Temp.	85 degC
Oil Gallery Temp.	100 degC
Inlet Air Pressure	0.05kPa
Air Charge Temp.	37 deg C
Inlet Air Temp.	30 degC

12.1.1.4 The laboratory ambient atmosphere shall be reasonably free of contaminants. The temperature and humidity levels of the operating area are not specified. A fan is allowed to divert air toward the turbocharger during break in only.

12.1.1.5 The break-in allows an opportunity to check PCM system operation, check for leaks in the various systems and purge air from the cooling systems. Specifications concerning the break-in procedure are shown in [Table 2](#) and [Table 3](#). The engine start-up and shutdown procedures are detailed in [12.2.1](#) and [12.2.4](#) respectively.

12.1.1.6 The same test PCM calibration U5J0110D1VEPfn13_78_2 is used during break in. Step 2 is a good time to check if the Lambda enrichment in the PCM calibration is working properly.

12.1.1.7 Oil Flush 1 is performed at the end of Step 1. Drain the used oil and remove the used oil filter. Let the oil drain for 15 minutes. Charge the engine with 3600 grams of new test oil. Prime a new oil filter with test oil and install. The engine is now ready to start Step 2 of the break in. Continue to run the break in until the end of Step 11 with the same oil charge.

12.1.1.8 Oil Flush 2 is performed at the end of Step 11 after the engine has idled for 5 minutes and shuts down. Drain the used test oil and remove the used oil filter. Let the oil drain for 15 minutes. Charge the engine with 3600 grams of new test oil. Prime a new oil filter with test oil and install. The engine is now ready to start Step 12 of the break in.

12.1.1.9 Oil Flush 3 is performed at the end of Step 12. Drain the used test oil and remove the used oil filter. Let the oil drain for 15 minutes.

12.1.1.10 Remove the timing chain for cleaning and 0 hour measurement according to the *Timing Chain Cleaning Procedure* listed in section 7.10 and *Timing Chain Measurement Procedure* listed in section 7.11. After measuring the chain, coat the chain in new test oil and install it back into the engine using the procedure described in the *Timing Chain and Camshaft Installation Procedure* listed in section 7.9.5.

12.1.1.10 After the timing chain has been installed, measure 3600 grams of test oil. With a portion of this 3600 grams of new test oil, prime a new oil filter and install it on the engine. Charge the engine with the remaining new test oil for the final oil charge.

12.1.1.11 Start and run the engine at idle for 5 minutes, then shut down the engine. Record the dipstick level in millimeters 20 ± 2 minutes after the engine is shutdown. Rotate the calibrated dipstick 360 degrees while still in the oil pan to capture the highest point. Remove the dipstick to view the reading. Break-in and the initial oil level measurement is now completed and test is ready to begin. No makeup is added to the test

12.2 Engine Operating Procedure:

12.2.1 *Engine Start-up*—Use the following detailed procedure each time the engine is started.

12.2.1.1 Turn on the ignition, safety circuits, fuel management system, fuel pump, and the blowby coolant pump.

12.2.1.2 Insure the intake-air supply duct is connected.

12.2.1.3 *Crank The Engine*—The engine should start within 4 seconds. Since the engine has a crankshaft driven oil pump, cranking oil pressure might be low. If used, disable a low oil pressure ignition shutoff during engine starting to allow the engine to start even though the oil pressure is low. The inclusion of this type switch could lead to excessive cranking time to start the engine.

12.2.1.4 If starting difficulties are encountered, the laboratory should not continue to crank the engine excessively. Perform diagnostics to determine the reason the engine will not start (ignition problems, insufficient or excess fuel, and so forth). (**Warning**— Excessive cranking times can promote additional fuel dilution of the test oil and can adversely affect the test. In addition to other precautions, do not attempt to pour gasoline into the intake-air horn.)

12.2.2 *Test Start*—Conduct the test according to the operational parameters shown in Table 4. The test stage and ramp order is shown in Table 5.

TABLE 4 Test Operational Parameters

Parameter	Units	Stage 1	Stage 2
Duration	Min	120	60
Engine Speed	RPM	1550 \pm 5	2500 \pm 5
Torque	NtM	50 \pm 2	128 \pm 2
Oil Gallery Temperature	degC	50 \pm 0.5	100 \pm 0.5
Coolant Out Temperature	degC	45 \pm 0.5	85 \pm 0.5
Coolant Flow	LPM	40 \pm 2	70 \pm 2
Inlet Air Pressure	kPa	0.05 \pm 0.02	
Inlet Air Temperature	degC	32 \pm 0.5	
Exhaust Back Pressure	kPa	104 \pm 2	107 \pm 2
Air Charge Temperature	degC	30 \pm 0.5	
AFR	Lambda	0.78 \pm 0.05	1 \pm 0.05
Blowby outlet Temperature	degC	23 \pm 2	78 \pm 2

12.2.2.1 Start the engine and let idle for 5 minutes then shut the engine down, these 5 minutes do not count toward

test time. Take a dip 20 ± 2 minutes after the engine shutdown. Follow the direction in section 12.3.4.2 on how to take the dip reading. Record the 0hr dip reading.

12.2.2.2 Start the engine and let idle for 5 minutes, these 5 minutes do not count toward total test time. Start the 30 minute ramp to stage 1 conditions. The test timer starts at the beginning of this ramp to stage 1. Use the ramping conditions shown in **Table 5**.

12.2.3 Cyclic Schedule, General Description:

12.2.3.1 The test is composed of two stages as shown in **Table 4 and 5**. Together, the two stages and two ramps comprise one cycle. Each cycle lasts 4 hours and is repeated 54 times for a total of 216 hours. Six consecutive cycles are completed each 24 hour period. Oil level measurement and sampling is performed every 24hrs. The oil level measurement and sampling procedure does not count toward test time and is described in section 12.3.4.

12.2.3.2 **Test Cycle:** Each cycle is 4 hours long and contains a Stage 2-1 ramp for 30 minutes (or start up/idle to stage 1 at test start or after an oil dip) , a Stage 1 for 120 minutes, a Stage 1-2 ramp for 30 minutes, a Stage 2 for 60 minutes. This is the only time that is counted as test time.

12.2.3.3 **Ramps:** The ramps between stages are 30 second engine speed and coolant flow ramps, 30 minute oil and coolant temperature ramps and 60 minute blowby temperature ramps, to stabilize at stage conditions. The load ramps different lengths. Ramp details are shown in Table 5. The ramps are considered complete after 30 minutes when the oil and coolant temperatures have reach stage conditions at this time the stage timer starts. Note that half of the blowby temperature ramp occurs during stage operation. The coolant and oil temperature ramps are linear ramps between the steady state stage conditions, within ± 2 minutes, for the first 25 minutes to reach the next stage conditions. After the next stage oil and coolant temperatures are achieved between 23 and 27 minutes, use the last remaining minutes of the 30 minute ramp to stabilize at the stage conditions shown in Table 4. **Figure A2.23 shows the desired shape of the ramps.** The rate of speed, temperature, fuelling and load changes, as well as the amount of enrichment between stages, can influence test severity and engine component wear. Therefore, ramping rates are very important.

TABLE 5 Stages Order and Ramp Description

Stage	Description	Time (min)
Stage 1	Stage 1 conditions	120
Ramp 1 – 2 (or start up/idle to stage 2)	30 sec speed and flow ramps, 3-3.5 minute load ramp, 30 minute oil and coolant temperature ramp, 60 minute blowby temperature ramp, to Stage 2 (Ramp 1-2 details below)	30
Stage 2	Stage 2 conditions	60
Ramp 2 – 1 (or start up/idle to stage 1)	30 sec speed ramp, 3.5-4.5 minute load ramp, 30min oil and coolant temperature ramp, 60 minute blowby temperature ramp, to Stage 1 (Ramp details below)	30



Stage ramp	Ramp details	
Stage 1-2 load ramp	30 sec 95-100 Nm 90 sec 115-120 Nm 180-240 sec 126-130 Nm	
Stage 2-1 load ramp	30 sec 75-85 Nm 90 sec 55-60 Nm 150-180 sec 48-52 Nm	
Stage 1-2 oil temperature ramp	reach 75 degC by 12.5± 2 minutes reach 100±0.5 degC by 25± 2 minutes remaining time to stabilize at 100±0.5	30
Stage 2-1 oil temperature ramp	reach 75 degC by 12.5± 2 minutes reach 50±0.5 degC by 25± 2 minutes remaining time to stabilize at 50+/-0.5	30
Stage 1-2 coolant temperature ramp	reach 65 degC by 12.5±2 minutes reach 85±0.5 degC by 25± 2 minutes remaining time to stabilize at 85±0.5	30
Stage 2-1 coolant temperature ramp	reach 65 degC by 12.5± 2 minutes reach 45±0.5 degC by 25±2 minutes remaining time to stabilize at 45±0.5	30
Stage 1-2 blowby temperature ramp	reach 49 degC by 15± 2 minutes reach 73 degC by 30±2 minutes reach 78+2 degC by 60 minutes (30 minutes of the this ramp is run during Stage 2)	60
Stage 2-1 blowby temperature ramp	reach 55 degC by 15± 2 minutes reach 32 degC by 30± 2 minutes reach 23+2 degC by 60 minutes (30 minutes of the this ramp is run during Stage 1)	60

12.2.4 Engine Shutdown:

12.2.4.1 *Scheduled Shutdown Procedure*—Follow the procedure detailed as follows, each time a scheduled shutdown is performed. Scheduled shutdowns include shutdowns that occur during engine break-in and oil leveling:

- (1) Bring the engine speed to idle. Temperatures and flows are set to go free flowing to cool the engine.
- (2) Switch the ignition off. Turn off power to the ignition power. Turn off fuel and coolant pumps.
- (3) Reduce the intake-air pressure to atmospheric.

12.2.4.2 *Unscheduled Engine Shutdown*—Follow the procedure detailed as follows, each time an unscheduled engine shutdown is performed:

- (1) Stop test timer when ramp down starts.
- (2) 30 second ramp to idle and all temperatures and flows are set free flowing to cool the engine down.
- (3) Let the engine idle for a total of 2 minutes, the 30 second ramp down counts as part of the 2 minutes. Shut the engine down after 2 minutes.
- (3) Switch the ignition off.

- (4) Turn off fuel and coolant pumps.
- (5) Reduce the intake-air pressure to atmospheric.

12.2.4.3 Start-Up After Oil Leveling Period—Follow the procedure detailed as follows, each time an engine start-up is performed after an oil leveling period.

(1) *Start*—5 min in idle; then ramp to stage 1 conditions for 30 minutes as shown in Table 5. The 5 minute of idle does not count toward the total test timer. The test timer starts at the beginning of the ramp to stage 1 conditions.

12.2.5 Unscheduled Downtime—The oil leveling periods of 25 ± 2 min are the only scheduled shutdowns allowed during the test. However, the test can be interrupted to perform necessary maintenance. Note all unscheduled downtime on the **Supplemental Operational Data Form** of the final test report.

12.2.6 Resumption of Test Time After Unscheduled Shutdown—After an unscheduled shutdown, test time does not begin until the engine has reached operating conditions for the stage at which the shutdown occurred. On start-up idle for 5 minutes then use the ramp as shown in Table 5 for reaching the appropriate stage.

12.2.6.1 Start-Up After Unscheduled Shutdown—Follow the procedure detailed as follows, each time an engine start-up is performed after an unscheduled shutdown.

Return to Stage 1—Engine idles for 5 minutes then ramp to stage 1 conditions for 30 minutes using the ramp as shown in Table 5. The total test timer and stage timer resumes from where it left off before being shut down once Stage 1 conditions are reached.

Return to Stage 2—Engine idles for 5 minutes then ramp to stage 2 conditions for 30 minutes using the ramp as shown in Table 5. The total test timer and stage timer resumes from where it left off before being shut down once Stage 2 conditions are reached.

12.3 Periodic Measurements and Functions:

12.3.1 Blowby Flow Rate Measurement— Every sixth cycle, measure and record the blowby flow rate at 30 min to 45 min into Stage 2. The engine shall be stable and operating at normal Stage 2 operating conditions. Measure blowby when the gas temperature is at least 32 °C. The installation of the blowby flow rate measurement apparatus is shown in Fig. 9 The procedure for measuring blowby flow rate is detailed in 12.3.1.1. Complete only one set (Stage 2) of blowby flow rate measurement during each six cycles. Under special circumstances additional blowby flow rate measurements can be performed to determine or verify a problem with the flow rate measurement apparatus or the engine. Record additional blowby flow rate measurements and an explanation of the reason for the additional measurements. Include these data in the supplemental operational data in the final test report.

12.3.1.1 Connect the blowby measurement device to the pressurized air source.

12.3.1.2 Open the flow valve (bleeder valve) completely.

12.3.1.3 Connect the blowby apparatus flow line to the 3-way valve located between the oil separator and intake tube.

12.3.1.4 Position the 2-way valve to divert air to the monometer from the hollow PCV valve.

12.3.1.5 Position the 2-way in between the PCV and throttle body to keep air from entering the throttle body.

12.3.1.6 Position the 3-way valve to divert intake manifold vacuum from the engine PVC to the exhaust plumbing of the blowby apparatus meter.

12.3.1.4 Adjust the flow valve (bleeder valve) to maintain crankcase pressure at (0 to 0.025) kPa.

12.3.1.5 Record the differential pressure across the blowby meter orifice, record the blowby gas temperature, and the barometric pressure.

12.3.1.6 After completing the measurement, return the engine to normal operating configuration. First, reposition the 3-way valve and both 2-way valves to ensure porting of the intake vacuum to the engine PCV; second, disconnect blowby apparatus hose from the closed port of the 3-way valve.

11.3.1.7 Calculate the blowby flow rate and correct the value to standard conditions (38 °C, 100.3 kPa) using the calibration data for that orifice.

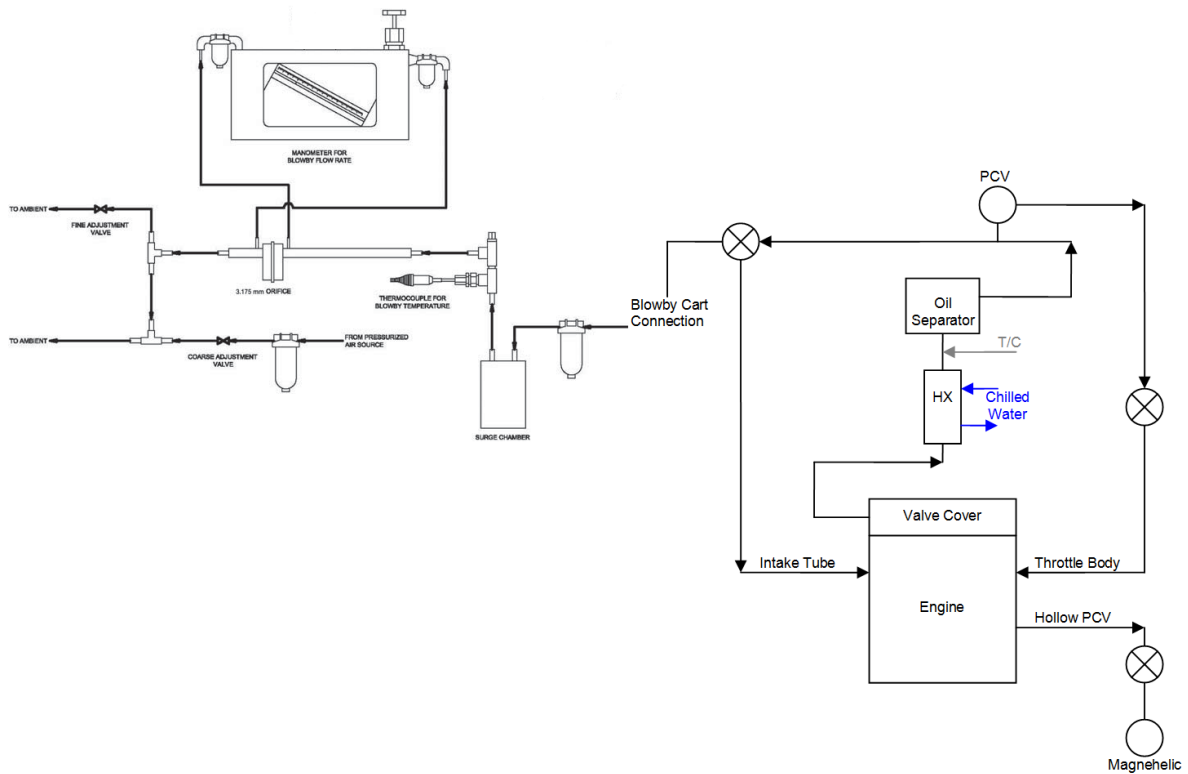

Figure 9 Blowby Cart Connection

12.3.2 PCM Parameter Logging

12.3.2.1 Refer to **Table 6** for parameter logging information.

TABLE 6 Parameter Logging

Mode	PID Number (Hex)	Parameter Description	Type	Bytes	Scale	Offset	Minimum	Maximum	Units
1	47	Absolute Throttle Position B	Unsigned Numeric	1	0.392156863	0	0	100	%
1	0E	Ignition Timing Advance for #1 Cylinder	Unsigned Numeric	1	0.5	-64	-64	63.5	Deg
1	11	Absolute Throttle Position	Unsigned Numeric	1	0.392156863	0	0	100	%
1	5	Engine Coolant Temperature	Unsigned Numeric	1	1	-40	-40	215	Deg C
1	0F	Intake Air Temperature	Unsigned Numeric	1	1	-40	-40	215	Deg C
1	34	Equivalence Ratio (Lambda)	Unsigned Numeric	2	3.0518E-05	0	0	2	Undefined / Not Used
1	43	Absolute Load Value	Unsigned Numeric	2	0.392156863	0	0	25700	%
1	0B	Intake Manifold Absolute Pressure	Unsigned Numeric	1	1	0	0	255	kPa
22	318	Actual Intake (A) Camshaft Position Bank 1	Signed Numeric	2	0.0625	0	-2048	2047.9375	Deg
22	319	Actual Exhaust (B) Camshaft Position Bank 1	Signed Numeric	2	0.0625	0	-2048	2047.9375	Deg
22	461	Charge Air Cooler Temperature Bank 1 Sensor 1 - Raw	Signed Numeric	2	0.015625	0	-512	511.984375	Deg C

12.3.4 Oil Sampling:

12.3.4.1 **Oil level Measurement and Sampling Procedure**— Oil level measurement and sampling occur at intervals of 24 hours or 6 cycles. The procedure and sample times are listed in **Table 7**. Every 6th cycle after Stage 2 has completed the total test timer stops. Perform a 30 seconds speed and load ramp to idle and have the engine idle for 4.5 minutes. Take the oil sample during these 4.5 minutes of idle. Oil sample is taken from the T connection on the oil filter housing leading to a valve. The location of the T where the oil is drawn is shown in **Figure A2.15**.

12.3.4.2 The minimum oil level allowed for this test is 100mm reading on the calibrated oil dipstick. Rotate the calibrated dipstick 360 degrees while still in the oil pan to capture the highest point. Remove the dipstick to view the

reading.

TABLE 7 Oil Level Measurements and Sampling

Test Hrs	24	48	72	96	120	144	168	192	216
Test Cycles	6	12	18	24	30	36	42	48	54
1	Remove a 120-150 mL purge sample while the engine is at idle.								
2	Remove a 60 mL analysis sample while the engine is at idle.								
3	Shut-down the engine 5 min after the start of oil sampling and leveling stage.								
4	Immediately return the purge sample to the engine.								
5	Record the dipstick level in millimeters 20 ± 2 minutes after the engine is shutdown.								
6	Log the oil level. The difference between the oil level and the Test Full mark is oil consumed or gained. Use the chart in Table X to determine the level.								
7	Restart the engine after shutdown.								

12.3.5 *General Maintenance*—The scheduled shutdown periods of 30 min during oil leveling allow limited opportunity for engine and stand maintenance. In addition, the test can be shut down at any convenient time to perform unscheduled maintenance. However, minimize the duration of a shutdown. Report any unscheduled shutdown on the Supplemental Operational Data Sheet.

12.4 *Special Maintenance Procedures*—Functions that require special maintenance procedures are listed in this section. These maintenance procedures are specifically detailed because of the effect on test validity or because they require special care while being completed. Check the oil level before performing any maintenance requiring removing the front cover or rear seal housing. If the level is **above XX mm**, the oil level is above the oil pan rail and a portion of the oil must be removed from the oil drain plug before performing the maintenance to insure oil doesn't leak over the pan rail. Use a clean container to catch the oil removed from the pan. Return the oil to the engine after the maintenance is completed before restarting the test.

12.4.1 *Blowby Flow Rate Adjustment*—A blowby adjustment can only be within the first 24 hours of the test. A blowby measurement is taken on the first test Stage 2 after break in (3.25-3.45hrs) gives a good hint on how the blowby will perform for the rest of the test. Blowby might drop from the post break-in level but the corrected average Stage 2 blowby for the test during the first 120 hours of the test must fall within the range from 65 L/min to 75 L/min as listed in **Table 8**. The first 24 hour blowby measurement must also be above 70 L/min. The Stage 2 times are also listed in **Table 8**. Adjust the blowby by changing the ring gaps or replacing piston rings as necessary. Suggested ring gaps are shown in **Table 9** that should produce the above blowby levels. These can be adjusted as necessary to achieve the correct blowby level. . Use the ring cutting procedure outlined in **7.8.5.2**.

TABLE 8 2nd Stage Blowby Readings

Stage 2 Blowby Readings		
Test Hours	Blowby Reading	Use these boxes for AVG.
3.5-3.75		
23.5-23.75		Must be above 70LPM
47.5-47.75		
71.5-71.75		
95.5-95.75		
119.5-119.75		
143.5-143.75		Blowby average between 65-75LPM.
167.5-167.75		
191.5-191.75		
215.5-215.75		

TABLE 9 Suggested Piston Ring Measurements

Top piston ring gap	0.065 inches
2nd piston ring gap	0.070 inches

12.4.1.1 *High Blowby Flow Rate Adjustment*—Reduce high blowby flow rate by replacing the compression rings with new rings that have smaller ring gaps.

12.4.1.2 *Low Blowby Flow Rate Adjustment*—Increase low blowby flow rate by increasing the ring gaps of the compression rings.

12.4.2 *Engine Disassembly and Reassembly for Maintenance (Before End of Test):*

12.4.2.1 Engine assembly and disassembly shall adhere to the procedures in 7.8 and 12.6.2, respectively

12.4.2.2 When the engine is disassembled for maintenance, drain as much test oil as possible from the oil pan into a clean container, and retain the oil for installation in the engine after reassembly. Take precautions to ensure the oil is not contaminated and to ensure the deposits are not disturbed on any parts. All parts should be placed in or over clean drain pans to collect oil that drains off while maintenance is being performed. The timing chain should be place in a container to prevent it from getting contaminated.

12.4.2.3 During reassembly, used drained test oil may be used to lubricate the engine parts. Do not use EF-411 oil or new test oil during engine reassembly. After the engine has been reassembled, charge the oil pan with the used test oil removed from the oil pan and collected from the engine parts during disassembly and maintenance. Do not add any new test oil to the pan.

12.5 *Diagnostic Data Review*—This section outlines significant characteristics of specific engine operating parameters. The parameters can directly influence the test or can be used to indicate normalcy of other parameters.

12.5.1 PCM parameters

12.5.2 *Engine Torque*—Engine torque is controlled in Stage 1 and 2 . It should remain relatively constant throughout a test and from test to test. Large differences in torque reading could be indicative of control or engine problems.

12.5.3 *Fuel Consumption Rate*—The fuel consumption rate should remain relatively constant throughout the test. Fuel consumption rate is not a specifically controlled parameter but is used as a diagnostics tool.

12.5.4 *Exhaust Gas Component Levels:*

12.5.4.1 Use the Lambda levels in the exhaust gas to determine the characteristics of combustion that occur



during the test. Use this parameter to determine the normalcy of combustion and any significant changes in combustion that occur throughout a particular test. Lambda in all two stages is controlled by the program in the Powertrain Control Module. No adjustments can be made to change the exhaust gas Lambda. If Lambda differs from what appears in [Table 4](#), check the PCM and test cell control system. Correcting a fault in the PCM and test cell control system is the only way to achieve the correct Lambda value.

12.5.5 Crankcase Pressure—Crankcase pressure is a function of blowby flow rate and PCV valve flow. High crankcase pressure is usually caused by high blowby flow rate or a significant loss of PCV valve flow. Incorrect three-way valve plumbing or port plugging also promotes high crankcase pressure. Low or negative crankcase pressure might be caused by low blowby flow rate or a restriction of vent air to the PCV valve.

12.5.6 Oil Pressure—The oil pressure is a function of oil viscosity and operating temperature. The oil pressure should remain consistent throughout the test, unless the oil exhibits a significant change in viscosity.

12.5.7 Oil Temperature Differential—The oil temperature differential is primarily a function of oil flow rate and oil viscosity and is normally stable throughout the test. The differential can change if the oil viscosity changes significantly during the test.

12.5.8 Coolant Temperature Differential—The coolant temperature differential is primarily a function of the coolant flow rate and is normally stable throughout the test. Large variations in the differential can be caused by coolant flow rate or temperature measurement errors.

12.6 End of Test Procedure:

12.6.1 Final Drain—Drain the engine coolant after the completion of the last test cycle. Engine oil can be drained with the engine in or out of the engine stand.

12.6.2 Engine Disassembly—During disassembly, ensure the original location of the parts can be identified with respect to either the cylinder number, valve location, bearings, etc.

12.6.3 Parts Layout for Measurement—Lightly wipe down the timing chain of any excess oil and make sure to keep the chain free of any contaminants or debris. Prepare the timing chain for end of test measurement as listed in the [Timing Chain Measurement and Cleaning Procedure](#).