

## 6. Apparatus (General Description)

6.1 The test engine is a Ford, spark ignition, four stroke, 4-cylinder gasoline turbocharged direct injection (GTDI) engine with a displacement of 2.0 L. Features of this engine include variable camshaft timing, dual overhead camshafts driven by a timing chain, four valves per cylinder and electronic direct fuel injection. It is based on the Ford Motor Co. 2012 Explorer engine with a displacement of 2.0 L.

6.2 Configure the test stand to accept a Ford 2.0L GTDI engine. All special equipment necessary for conducting this test is listed herein.

6.3 Use the appropriate air conditioning apparatus to control the temperature, pressure, and humidity of the intake air to meet the requirements in [Table 4](#).

6.4 Use an appropriate fuel supply system ([Fig. 1](#)).

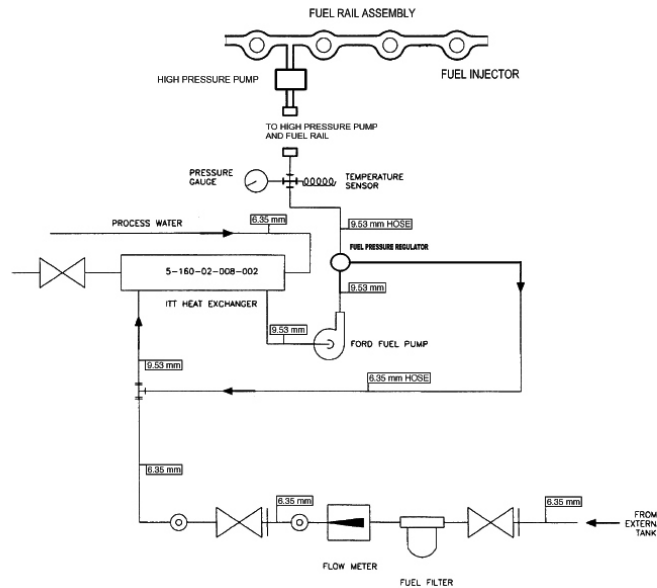

Figure 1  
Fuel System Schematic

6.5 The control and data acquisition system shall meet the requirements listed in [Annex A3](#).

## 7. Apparatus (The Test Engine)

7.1 **Sequence??** Test Engine—The test engine parts are available from the Ford Motor Co. A detailed listing of all parts is given in ([Ammex A1.1 through A1.6](#)).

7.1.1 Engine parts other than valve train and drive parts can be replaced during the test, provided the reason for replacement was not oil related.

7.2 Required New Engine Parts—Use new parts listed in test parts list ([see A1.4](#)) and the gaskets list ([A1.5](#)) for each test. New valve train drive parts and piston rings must be used for each test. Do not modify or alter test parts without the approval of **Sequence ??** Surveillance Panel.

7.3 Reusable Engine Parts—The parts listed in the reusable engine parts list ([A1.2](#)), test stand set up kit ([A1.6](#)), and fastener kit ([A1.3](#)) can be reused (all of these can be used in numerous engine assemblies as long as they remain serviceable). Crankshaft and bearings, connecting rods and bearings, pistons, camshafts, timing chain covers, cylinder blocks, cylinder head assemblies, turbocharger, PCV valve and fuel injectors may be used for a maximum of 6 tests as long as they remain serviceable. The PCV valve is flow tested before each test to insure it meets the required flow. These parts should be kept together as a set for all 6 tests. Damaged threads in the block can be corrected with commercially available thread inserts.

7.4 Specially Fabricated Engine Parts—The following subsections detail the specially fabricated engine parts required in this test method:

7.4.1 Intake Air System ([see Fig. A2.12](#)) Intake air system can be fabricated but must use the stock 2012 Explorer air cleaner assembly ([A1.6](#)) and MAF.

7.4.5 Oil Pan and pick up tube—Use a modified oil pan with dipstick, fill port and pick up tube listed in [A1.7](#) and shown in [Fig. A2.1](#). These can be obtained from the supplier listed in [A9.2](#).

7.4.7 Driveline—Use the flywheel, clutch, pressure plate, bell housing, clutch spacer listed in Annex (A1.7) from the supplier listed in A9.2.

7.5 Special Engine Measurement and Assembly Equipment—Items routinely used in laboratory and workshop are not included. Use any special tools or equipment shown in the 2012 Explorer service manual for assembly. A list of these tools is shown in Annex A1.8. Complete any assembly instructions not detailed in Section 7 according to the instructions in the 2012 Explorer Service Manual.

7.5.1 Piston Ring Positioner—Use the piston ring positioner to locate the piston rings from the cylinder block deck surface by 38 mm. This allows the compression rings to be positioned in a consistent location in the cylinder bore for the ring gap measurement. Fabricate the positioner according to the details shown in Fig. A2.17.

7.5.2 Piston Ring Grinder—A ring grinder is required for adjusting ring gaps. A suitable ring grinder is noted in 7.8.5.1.

7.5.4 Engine Service Tools—A complete list of special tools for the test engine is shown in Annex A1.8. The tools are available from a Ford dealership. These are designed to aid in performing several service items, in addition to the following specific service items that require special tools to perform the functions indicated (if not self-explanatory).

7.5.7 Engine Parts Cleaning—Clean the cylinder block, cylinder heads, pistons, oil pan and front cover using Tierra Tech model MOT500NS ultrasonic parts cleaner or similar apparatus. See X2.1.18. Rinse parts with parts cleaning soap, NAT-50 or PDN-50 (Annex X2. 23) before putting into ultrasonic cleaner.

After all the measurements, the engine is ready for cleaning. Put all of the following components into ultrasonic parts cleaner for 30 minutes:

- Cylinder block with main bearings. Oil jets are removed.
- Bare pistons without wristpins (The piston compression and oil rings are removed from each piston prior to going into the ultrasonic cleaner, they will get replaced with a new set)
- Bare cylinder head (No valvetrain components)
- OHT oil pan
- Front cover

The ultrasonic parts cleaner solution is also provided by Tierra Tech, Ultrasonic solution 7 and B (X2.1.19). The cleaning procedure is described below:

Add solution once ultrasonic machine reaches a minimum of 140°F. DO NOT add the degreasers until the ultrasonic machine has reached a temperature of 140°F.

a. 5 ½ gallons of ultrasonic solution 7

b. ½ gallon of ultrasonic solution B

c. Change the soap and water solution at least after every 25 hrs. of use.

\*Note: The solution shown above is based upon the MOT-500NS model (158 gallon capacity). Quantities will be different for a different size unit.

After 30 minutes, the parts are removed and immediately sprayed with hot water, then solvent and left to air dry.

The remaining components are spray cleaned with Stoddard solvent then blown out with pressurized air and left to air dry:

- Camshafts and all valve train.
- Intake manifold/ Throttle body (not being separated)
- Fuel pump housing with piston.
- Vacuum pump and oil screen.
- Intake and outlet of the turbocharger are lightly wiped down with solvent. The oil screen is also cleaned. (We don't clean the inside of the turbocharger)
- The carbon build up on the injectors is wiped of
- Oil Pump
- VCT solenoids are sprayed with solvent.
- Valve Cover
- Turbo charger oil lines
- Oil separator (PCV housing on the cylinder block)
- Oil pick up tube
- Oil squirters/jets

- Crankshaft
- Rods and pins
- All valvetrain
- The test batch camshaft sprockets and crankshaft gear.
- The test batch timing chain is cleaned as described in the Timing Chain Cleaning Procedure.

7.5.8 Cylinder Deglazing—Use a flexible cylinder hone Flex Hone Model: GB31232 and Pneumatic Honing Drill, Westward 1/2 Reversible Air Drill, Model: 5ZL26G to deglaze the cylinder walls. See [X2.1.20](#) and [X2.1.21](#)

7.5.9 PCV Valve Flow Rate Device:

7.5.9.1 Use this device to verify the flow rate of the PCV valve before each test and measure the degree of clogging after the test. Fabricate the device according to the details shown in Fig. A2.22. The device shall have a full scale accuracy of 5 % and a resolution of 0.05 L/s (see 7.6.7).

7.6 Miscellaneous Engine Components-Preparation:

7.6.1 Engine Build-Up and Measurement Area-Environment—The ambient atmosphere of the engine buildup and measurement areas shall be reasonably free of contaminants. A relatively constant temperature (within  $\pm 3$  °C) is necessary to ensure acceptable repeatability in the measurement of parts dimensions. To prevent moisture forming on cold engine parts that are brought into the buildup or measurement areas, maintain the relative humidity at a nominal maximum of 50 %.

7.6.2 Throttle Body:

7.6.2.1 Clean the butterfly and bore of the throttle body with carburetor cleaner (Chemtool B12) (X2.1.34) and air-dry before each test. Do not disassemble the throttle body as this will cause excessive wear on the components. The idle air screw can be removed for the cleaning process. Fully close the idle air screw during test operation.

7.6.2.2 There is no specific life for the throttle body. However, the clearance between the bore and the butterfly will eventually increase and render the body unserviceable. When the clearance becomes too great to allow control of speed, torque, and air-fuel ratio, discard the throttle body.

7.6.3 PCV Valve— If reusing the PCV valve clean before each test by lightly spraying the inside with (Chemtool B12) (X2.1.34) or any equivalent solvent compatible with the PCV valve materials, let air dry or lightly dry off with compressed air. For new and used PCV valves measure and record the flow rates with the calibrated flow device described in 7.5.9 and Fig. A3.19. Measure the flow rate at 27 and 60 kPa vacuum. Because of the hysteresis in the PCV valve spring, make the vacuum adjustments in one direction only. Measure the flow rate twice and average the readings. Reject any PCV valve that does not exhibit an average flow rate of 36 - 54 L/min at 27 kPa and 19 to 21 L/min at 60 kPa

7.6.4 Water Pump Drive System—Use only the pulleys and belt provided in the [Sequence ??](#) test stand set-up parts list (see [Annex A1.6](#)), crankshaft pulley, water pump and pulley, tensioner, and six groove belt shown in [Figure 6](#).

7.6.5 Oil Separators—Clean with degreasing solvent ([7.7.1](#)) and allow to air-dry.

7.7 Solvents and Cleaners Required—No substitutions for [7.7.1 – 7.7.5](#) are allowed. (Warning—Use adequate safety provisions with all solvents and cleaners. See [Annex X1](#).)

7.7.1 Solvent—Use only mineral spirits (ie Stoddard Solvent) meeting the requirements of Specification D235, Type II, Class C for Aromatic Content (0 to 2) vol %, Flash Point (61 °C, min) and Color (not darker than +25 on Saybolt Scale or 25 on Pt-Co Scale). (Warning—Combustible. Health hazard.) Obtain a Certificate of Analysis for each batch of solvent from the supplier.

7.7.2 Organic Solvent, Penmul L460. (Warning—Combustible. Health hazard.). [Annex X2.1.22](#)

7.7.4 Ultrasonic Cleaner, Tierra Tech ultrasonic solution 7 and B available from supplier shown in [Annex X1.4](#).

7.7.5 Parts Cleaning Soap, NAT-50 or PDN-50 have been found to be acceptable. (Warning—Health hazard.) [Annex X2.1.23](#)

7.8 Assembling the Test Engine-Preparations—Use the long block obtained from the supplier in [A9.1](#). If this is the first test on a new engine, disassemble the long block in accordance with the 2012 Explorer workshop manual.

Required new parts and reusable parts are listed in [Annex A1](#).

7.8.1 Parts Selection—Instructions concerning the use of new or used parts are detailed in [7.1.1](#), [7.2](#), and [7.3](#).

7.8.2 Sealing Compounds—Use a silicon-based sealer as needed on the contact surfaces between the rear seal housing and oil pan and the front cover and cylinder block, cylinder head and oil pan. Use Motorcraft Gasket Maker between (TA-16) or equivalent between the 6<sup>th</sup> intake and exhaust camshaft cap and the cylinder head.

7.8.2.1 Use silicon-based sealer sparingly since it can elevate the indicated silicon content of the used oil.

NOTE 1—Non-silicon liquid or tape thread sealers can be used on bolts and plugs.

7.8.3 Gaskets and Seals—Install new gaskets and seals during engine assembly.

7.8.4 Block Preparations—Inspect block, including oil galleries for debris and rust. Remove any debris or rust that is found. Remove oil gallery plugs. Removal of coolant jacket plugs is left to the discretion of the laboratory.

7.8.4.1 **Deglazing Procedure:** Deglazing is performed after ultrasonic cleaning under the following conditions to achieve a 9ra to 13ra and 30+5 degree crosshatch:

1. Mount the engine block in an engine stand or suitable fixture so it is secure and will not move during deglazing operation.
2. Rinse cylinder bores with Stoddard solvent.
3. Deglaze cylinder bores using drill and hone shown in Figure 3 and Figure 4.
4. Run the drill at 500 rpm horizontal drill speed for 25 to 35 vertical strokes over elapsed time of 20 to 25 seconds. There should be a steady supply of lubricant supplied during each stroke.
5. 50/50 ratio, Stoddard Solvent (mineral spirits) and EF411, is the hone lubricant used.
6. Clean cylinders after honing deglazing with warm/hot water or hot water and Tide detergent using a brush, then oil cylinders with EF411.
7. Replace ball hone after deglazing 24 engine blocks
8. Measure surface finish and crosshatch.



**Figure 3: Pneumatic Honing Drill**

Pneumatic Honing Drill

Brand: Westward

1/2 Reversible Air Drill

Model: 5ZL26G

RPM: 500

Max Psi: 90

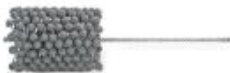

**Figure 4: Cylinder Hone**

Flexible Cylinder Hone

Brand: Flex Hone

Model: GB31232

Bore Dia.: 3-1/2"

Abrasive Material: Silicon Carbide Grit 320

#### 7.8.4.2 Crosshatch Procedure:

##### Materials:

1. Hatchview Software (<http://digitalmetrology.myshopify.com/products/hatchview>) (X2.1.24)
2. USB microscope. (X2.1.25)
3. Computer System Requirements: Windows XP, Vista or Windows 7 (32 or 64 bit), an available USB 2.0 port is required for live “video” viewing.

##### Preparation:

1. Cylinder should be clean of any oil or residue from honing to maintain consistency of measurements.
2. Adjust focus of camera while face of the camera is placed against the cylinder wall.
3. Set camera resolution to 640x480 and 30 fps.
4. Use the identification feature available in the program to title the image with cylinder number and test number.

##### Measurement:

1. The measurement is taken at the rear most longitudinal position of each cylinder.
2. The measurement is taken at 1.5 in. down from the top of the cylinder deck. A ruler is used to measure.
3. The measurement is to range for 25° to 35° with a target of 30°

#### 7.8.4.3 Crankshaft preparation

- (1) Clean the crankshaft according to section 7.5.7
- (2) Spray the crankshaft with degreasing solvent.
- (3) Measure the main journals and connecting rods journals (horizontal diameter, vertical diameter) bearing inside diameter and clearance and verify that they meet the service limits.

(5) The crankshaft is polished with 400 grit 3M utility cloth while it is still lightly coated in Stoddard solvent. A final finish is given using 600 grit crocus cloth. The crankshaft is cleaned with Stoddard solvent for the final time.

7.8.4.4 Piston and rod assembly: Clean the pistons according to section 7.5.7. Measure piston, piston pin and pin rod hole diameters to insure they meet service limits. Install the pistons on the connecting rods per the procedure in the 2012 Explorer workshop manual.

#### 7.8.5 Piston Rings:

##### 7.8.5.1 Ring Gap Adjustment:

The piston rings are cleaned and wiped with EF411 to get the factory coating off. The 1st ring is gapped to .065” and the second ring is gapped to .070”. These gaps have been shown to produce acceptable blowby levels with the surface finish and crosshatch pattern achieved in 7.8.4.1. but may need to be adjusted to achieve a 24 hour minimum blowby level of 70 L/min and an average blowby of 65-75 L/min. The ring placement is 1.5” (38mm) from the deck using ring positioner shown in Figure A2.17.

##### 7.8.5.2 Piston Ring Cutting Procedure:

- (1) Cut the top and second compression ring gaps to the required gap using the Sanford Piston Ring Grinder. (X2.1.26) ring cutting burr (X2.1.27) rotated at a rated speed of 3450 r/min. Remove equal amounts from both sides of the gap. Make final cuts on the down stroke only. The ring is cut with a maximum increment of 0.125 mm until the desired ring gap is achieved.

(2) After the rings are cut remove the ring from the cutting tool, debur using a Sunnen soft stone (X2.1.28) and wipe with a dry towel.

#### 7.8.5.3 Installation:

(1) Install the oil control rings and the compression rings on the pistons with the gaps located over the piston pin. Position the gaps at approximately 180° intervals, with the top compression ring gap toward the rear. Install the rings using a ring spreader tool, keeping the rings' surfaces parallel to the ring groove in the piston.

(2) If any rings require replacement, then measure and record the new ring gap(s)

7.8.6 Cylinder Bore Measurements—Measure the cylinder bores with the bearing caps in place. Clean the bores with a dry rag. The bores shall be clean and dry when they are measured. Use a bore gage micrometer to determine the diameter of cylinders at the top, middle and bottom using the bore ladder shown in figure A2.18.

7.9 Assembling the Test Engine-Installations—Assemble the engine according to the instructions in the 2012 Explorer service manual unless specified herein.

7.9.1 Cylinder block— The heater hose tube is removed from the block as shown in Figure 5 and plugged with a 5/8” freeze plug coated in RTV.



**Figure 5: Cylinder Block Heater Hose Tube**

7.9.2 Piston Installation—Install piston and rod assemblies in proper cylinders, taking care to ensure rings are not damaged during installation. Wipe the cylinders with EF-411. Install the pistons and connecting rods with the notches facing the rear. Install the rod bearing caps and torque according to the procedure in the 2012 Explorer workshop manual.

7.9.3 Oil System Components—All oil system components in the engine are production configuration with the exception of the oil pan and the oil pickup tube, shown in figure A2.1.

7.9.4 Cylinder Head Installation—Cylinder heads are obtained from the supplier in A9.1. Heads may be used for up to 6 tests, as long as they remain serviceable.

(1) Disassemble heads and inspect for any debris or other deleterious materials and remove as necessary.

(2) Clean the cylinder head in the Ultrasonic cleaner as described in section 7.5.7.

(3) Determine valve guide clearance at the top and middle of the heads on the transverse side of the guide. Reject any heads that exceed the service limits shown in the 2012 Explorer work shop manual.

(4) Measure and record intake and exhaust valve springs, spring free length, and spring load at a compressed height of 28.7 mm. Verify the compressed spring load is 460±21 N. Reject any springs not meeting this criteria.

(5) Assemble the cylinder heads in accordance with the service manual. The valves are lapped before installation and new intake and exhaust valve seals are installed.

(6) Set the valve lash per the procedure in the workshop manual and record the valve lash.

7.9.5 Chain and Camshaft Installation Procedure: Measure the test chain according to the Timing Chain Measurement Procedure (7.11) prior to installing it in the engine. Install camshaft and timing chain according to the procedure in the 2012 Explorer work shop manual. If using the Ford camshaft alignment tool (Ford P/N 303-1565) (X2.1.29) be sure not to let it bind in slots at the rear of the camshafts. It should be loose after the timing chain installation is complete. Be sure camshaft positioning tool is flat before installing. Use a spanner on the harmonic balancer or a flywheel lock to hold the crankshaft. Alternate method, the crankshaft positioning crankshaft TDC timing peg (Ford P/N 303-507) (X2.1.30) can be used to hold the crankshaft in place while performing this

installation. Install the timing chain with the lettering on the black link facing forward. This will insure the chain is installed in the same orientation if/when it is removed and reinstalled during the test. Coat the timing chain with test oil every time it is installed in the engine other than the pre break in installation. The timing chain gets coated with EF-411 when it is first installed before break in. Install the chain tensioner and guides according to the 2012 Explorer workshop manual. After the tensioner is installed and the pin is pulled from the tensioner to release the tensioner arm, do not move or apply any force to the tensioner arm.

7.9.6 Balance Shaft Housing— Do not install the balance shaft housing; it cannot be used with the test oil pan. The balancer is removed and the oil passage is plugged with a CFM Balance Shaft Delete Kit (Part number 1-0180) (X2.1.31).

7.9.7 Oil Pan and Baffle—Install oil pan baffle to the oil pan as shown in Fig. A2.1. Install the oil pan according to the procedure in the 2012 Explorer service manual.

7.9.8 Water Pump, Water Pump Drive—Install the water pump and pulley, the crankshaft pulley, and tensioner according to the 2012 Explorer service manual. These are the only components needed to drive the water pump. All other production front end accessory drive components do not need to be installed. The engine cannot be used to drive any external engine accessory other than the water pump. Pull back tensioner and install water pump drive belt as shown in Fig. 6. Ensure that there is a minimum contact angle of 20° between the drive belt and the water pump pulley.

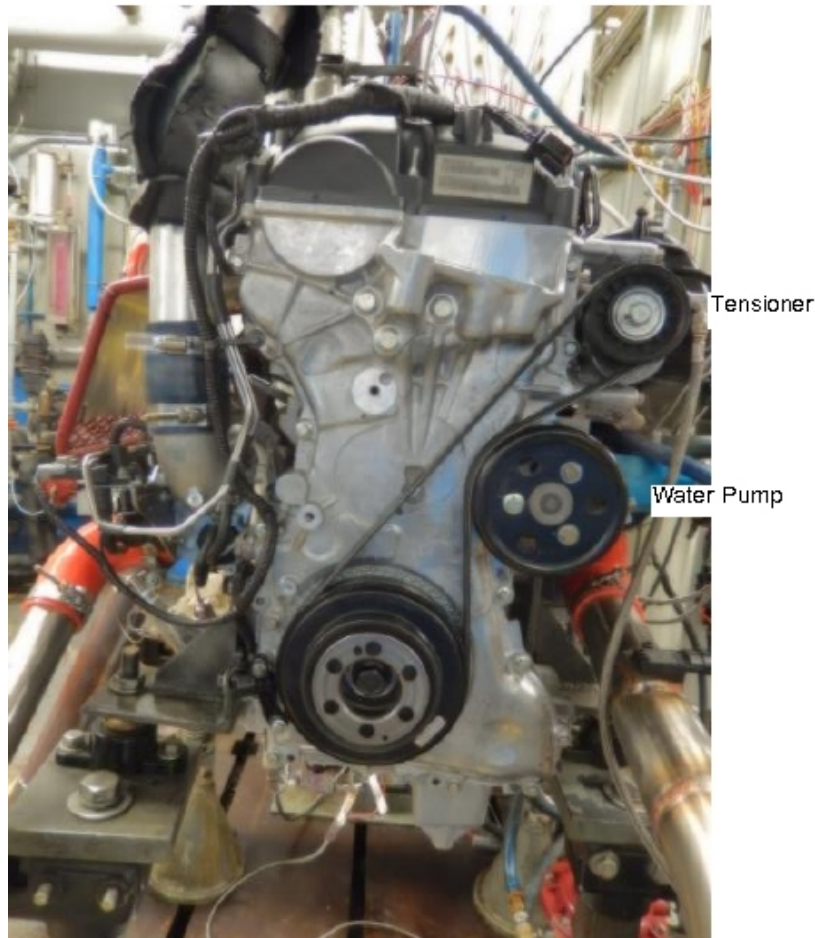

FIG. 6 Water Pump Drive Arrangement

7.9.9 Engine cooling system – Use coolant inlet and outlet from the supplier shown in A9.2. Do not install the thermostat. Plumb the external coolant system as shown in **Figures A2.2 and A2.3**. Use coolant flow meter with an accuracy of  $\pm 1\%$ .

7.9.9.1A radiator cap is used to limit system pressure to 105 kPa. Pressurize the coolant system to  $(70 \pm 10)$  kPa at the top of the coolant reservoir

7.9.9.2 The engine coolant flow rate and outlet temperature are controlled in accordance with the specifications listed in Table 4. Cyclic ramping specifications are detailed in Table 5..

7.9.9.3 As a minimum, inspect and clean the engine coolant system components, external to the engine, as needed prior to running each reference calibration test. The coolant side of the system typically doesn't need cleaning but may need routine cleaning of the process water side. A specific flushing technique is not specified. However, the technique should employ a commercial descaling cleaner.

7.9.10 Cylinder block oil separator - Install a dummy PCV valve (PCV valve with the internal components removed) in oil separator on the side of the engine block. A functional PCV is located at the stand in the external ventilation system. This is the location to measure crankcase pressure.

7.9.11 Oil cooling system – Use the production oil cooler (BB3Z-6A642-A) attached to the oil filter adapter. Use process water on the coolant side to control the oil temperature. Oil temperature is controlled by a control valve on the process water inlet line to control the flow of process water through a feedback loop from the oil in thermocouple.

## 7.10 Chain Cleaning Procedure and Measurement Steps

New Chain preparation:

1. Place a new timing chain into an ultrasonic bath with Stoddard solvent for 20 minutes.
2. Remove the chain from the ultrasonic cleaner and dip into room temperature Stoddard solvent to cool chain. Dip the chain in heptane or solvent 142 to prevent rust. ~~before measuring.~~
3. Oil chain by dipping in EF-411.
4. Install the chain in the engine (7.9.5) for engine break in

After break in

1. After break in remove the chain from the engine.
2. Place the timing chain into an ultrasonic bath with Stoddard solvent for 20 minutes.
3. Remove the chain from the ultrasonic cleaner and dip into room temperature Stoddard solvent to cool chain. Dip the chain in heptane or solvent 142 to prevent rust before measuring.
4. Oil chain by dipping in EF-411
5. Hang the chain to let excess oil run off and let the chain ~~dry and~~ cool off for a minimum of 2 hours in the metrology lab before starting the measurement procedure. This will allow the temperature of the chain to stabilize..
6. Measure chain (7.11)
7. After break in measurement dip the chain in Stoddard Solvent to remove EF-411 then dip the chain in new test oil.
8. Install the chain in the engine for the start of test.

**(Note: Do not clean the timing chain if it is removed during the test for an engine repair)**

End of Test Chain

1. At the end of test, remove the timing chain from the engine.
2. Place the timing chain into an ultrasonic bath with Stoddard solvent for 20 minutes.
3. Remove the chain from the ultrasonic cleaner and dip into room temperature Stoddard solvent to cool chain. Dip the chain in heptane or solvent 142 to prevent rust before measuring.
4. Oil chain by dipping in EF-411.
5. Hang the chain to let excess oil run off and let the chain ~~dry and~~ cool off for a minimum of 2 hours in the metrology lab before starting the measurement procedure. This will allow the temperature of the chain to stabilize.
6. Measure chain (7.11)



7.11 Timing Chain Measuring Procedure: The timing chain is measured two times during the test; after the 8 hour engine break in and at the end of the test.

- Use the Motorized chain measurement apparatus, MCMR 1000 (A9.6) shown in Figure 7.
- Parts list show in A1.8



Figure 7: Chain Measurement Apparatus

#### Chain Measurement Rig Calibration

Check calibration standard on the measurement apparatus before every test chain measurement using a reference chain and insure the reference chain measurement is within 0.001” of the previous measurement then proceed to test chain measurement. If not, adjust the rig to achieve a measurement within 0.001” of the last correct reading. The lab needs to have single new unused chain that is used as a reference chain and this chain is only used for calibrating the measurement apparatus.

#### Chain measurement procedure

1. Orient the sprockets of the measurement apparatus such that they are aligned with their alignment orientation marks.
2. Install chain on measurement apparatus with the “key” link in the standard (aligned) location.
3. Insure that the USB digital interface cable between the indicator and the computer is connected and that the first cell of the spreadsheet is selected into which the data will begin being entered.
4. Energize the drive motor on the chain measurement apparatus and run until a minimum of 30 chain lengths worth of reading have been captured (207 sprocket revolutions).
5. When complete, examine the three subset measurements and verify the total range does not exceed  $\pm 0.0003$ ”  $\pm 0.0002$ ”; if it does, repeat the measurement by overwriting the data.
6. Report the 3 subset average measurements from each chain measurement. Report that average of the 3 subset average measurements (this average is the final chain measurement used in the calculation below).
7. Chain elongation =  $2 * (\text{EOT average measurement} - \text{initial average measurement}) / \text{nominal chain length}$ . The nominal chain length is 43.125”.

7.12 Engine Installation on the Test Stand—Functions that are to be performed in a specific manner or at a specific time in the assembly process are noted.

7.12.1 Mounting the Engine on the Test Stand—Mount the engine on the test stand so that the flywheel friction face is  $(0.0 \pm 0.5)^\circ$  from vertical. Four motor mounts are used (Quicksilver part# 6628-A) (X2.1.33) as shown in Figure A2.4 and Figure A2.5. Drawings of the mount brackets can be found in the Figure A2.6 and Figure A2.7. The engine must be at  $(0.0 \pm 0.5)^\circ$  roll angle.

7.12.1.1 Flywheel: The flywheel bolts get lightly coated with Loctite 565 to prevent any oil from seeping out of the holes. Torque the flywheel to 108-115 Nm. The flywheel is obtained from the supplier in A9.2

7.12.1.2 Clutch and pressure plate - The clutch, pressure plate and spacer are obtained from the supplier in A9.2. Put the flat side on the clutch toward the engine. The spacer goes between the flywheel and pressure plate. Torque the pressure plate bolts to 25-33 Nm. Each clutch gets replaced every 6 runs.

7.12.1.3 Driveline: The driveline is greased every test. Driveline specifications:

- A. Driveline Degree:  $1.5 \pm 0.5$  degrees
- B.  $595 \pm 13$  mm installed length from flange to flange
- C. 1410 series flanges
- D. 2.75" pilot
- E. 3.75" bolt circle
- F. 3.50" x .083" stub and slip

7.12.1.4 Dynamometer: Use Midwest dynamometer model 1014A. Dynamometer can be purchased from the vendor shown in Annex X2.1.32

7.12.2 Exhaust System and Gas Sampling Fittings:

7.12.2.1 A typical exhaust system, and fittings for backpressure probe, O<sub>2</sub> sensors and thermocouple are illustrated in Figs. A2.8. Exhaust components should be constructed of either solid or bellows pipe/tubing. Other type flexible pipe is not acceptable.

7.12.2.2 The backpressure probe can be used until they become unserviceable. If the existing probes are not cracked, brittle, or deformed, clean the outer surface and clear all port holes. Check the probes for possible internal obstruction and reinstall the probes in the exhaust pipe. Stainless steel probes are generally serviceable for several tests; mild steel probes tend to become brittle after one test. Exhaust gas is noxious. (Warning—Any leaks in the connections to the sample probe will result in erroneous readings and incorrect air-fuel ratio adjustment.)

7.12.4 Fuel Management System:

7.12.4.1 Fuel Injectors:

(1) The fuel injectors can be used for 6 test.

(2) Inspect the O-rings to ensure they are in good condition and will not allow fuel leaks, replace if necessary. Install the fuel injectors into the fuel rail and into the cylinder head.

7.12.4.2 Powertrain Control Module: The engine uses a PCM provided by Ford Motor Company to run this test.

The PCM contains a calibration developed for this test, use a PCM that contains calibration U5J0110D1VEPfn13\_78\_2. The PCM module is available from the supplier listed in A9.2.

(1) The PCM power shall come from a battery ( $13.5 \pm 1.5$ ) V or a power supply that does not interrupt/interfere with proper PCM operation. Connect the PCM battery/power supply to the engine wire harness with an appropriate gage wire of the shortest practical length so as to maintain a dc voltage of (12 to 15) V and minimize PCM electrical noise problems. Ground the PCM ground wire to the engine. From the same ground point, run a minimum two gage wire back to the battery negative to prevent interruption/interference of the PCM operation. The power supply can also be used for the Lambda measuring devices.

7.12.5 Spark Plugs—Install new Motorcraft CYFS-12-Y2 spark plugs. Spark plugs come pre-gapped. Torque the spark plugs to 9 to 12 N·m. Do not use anti-seize compounds on spark plug threads.

7.12.6 Crankcase Ventilation System—The crankcase ventilation system is a closed system allowing blowby to be vented from the crankcase and drawn into the intake manifold. The metal parts of the crankcase ventilation system get flushed with carburetor cleaner (Chemtool B12) (X2.1.34) or any equivalent solvent after every test, then blown out with pressurized air and are left to air dry. All the hoses (ie tygon) get replaced every test. If using a smooth bore Teflon braided stainless steel hose, these can be reused after cleaning in an industrial degreaser (Penmul L460). A diagram of the crankcase ventilation system is shown in Figure A2.9 and A2.10.

7.12.6.1 System description: - Blowby flows through the oil drain back passages in cylinder block and head and through the front cover and out through the camshaft cover. The blowby heat exchanger and oil separator prevents loss of oil, fuel and water into PCV system. A typical heat exchanger cooling system is shown in Figure A2.11. The PCV valve flows approximately 120 L/min. Blowby flowrate is 65 to 75 L/min. When excessive plugging of the

PCV valve occurs or there is excess blowby, the blowby is vented to the fresh air tube after the mass air flow sensor. A dummy PCV valve (PCV valve with the internal components removed) is placed in the stock PCV valve location in the block mounted oil separator is used for crankcase pressure measurement.

7.12.6.2 Blowby Heat Exchanger and Oil Separator: Use ITT Heater exchanger S-160-02-008-002 (X2.1.9) and Moroso oil separator, Part number 85487 (A9.4). Disassemble and soak both in Penmul L460 (X2.1.22) for 24hrs. Rinse with hot water, then rinse a final time with Stoddard solvent and let air dry or use other suitable laboratory based cleaning method compatible with the heat exchanger and oil separator materials and leaves no residue.

7.12.7 Intake Air Components—Install the fresh air tube, air cleaner assembly, and new air filter. Modify the air cleaner assembly to accept fittings for inlet air temperature thermocouple and pressure tap as shown in Fig. A2.12. The excessive blowby tube is shown connected to the fresh air tube after the MAF sensor. Use the 2012 Explorer fresh air tubes or fresh air tubes can be fabricated but must be  $1040 \pm 25$  mm from the MAF sensor to the turbocharger inlet.

7.12.7.1 Water to Air Turbocharger Intercooler - Use water to air intercooler (A9.5) capable of achieving the required air charge temperature (Table 4) and an average system pressure loss less than 3 kPa in both stages. The intercooler accumulates significant amounts of blowby condensate during each test. The air side of the intercooler must be spray cleaned with Stoddard solvent, rinsed with hot water and left to air dry before each test. Use commercial Aqua Safe descaler to clean the water side.

7.12.7.2 Intercooler Tubing: Fabricate the intake air system with 51 mm ID stainless steel tubing from the turbocharger to the intercooler and 64 mm ID stainless steel tubing from the intercooler to the throttle body. The tubing length is not specified but should be the appropriate length to achieve the required air charge temperature and system pressure loss. Locate the MAPT sensor  $305 \pm 25$  mm from the intake surface of the throttle body and the intake air charge temperature thermocouple 25 mm downstream from the MAPT sensor. The post-intercooler turbo boost pressure measurement probe should be placed a minimum of 12 inches upstream from the MAPT sensor. The pre-intercooler turbo boost pressure measurement probe should be placed a minimum of 12 inches downstream from the turbocharger outlet. The measurements can be seen in Figure A2.13 and typical installation is shown in Figure A2.14.

7.12.8 External Hose Replacement—Inspect all external hoses used on the test stand and replace any hoses that have become unserviceable. Check for internal wall separations that could cause flow restrictions. Check all connections to ensure security.

7.12.9 Wiring Harness—There are two wiring harnesses used on the test stand, a dynamometer harness that connects to the stand power and PCM and an engine harness. Obtain the dynamometer wiring harness and engine wiring harness from the supplier listed in A9.2. Diagrams of these wire harnesses are shown in Figures A2.20 and A2.21 identifying connections.

7.12.10 Electronic Throttle Controller: Throttle is controlled using simulated accelerator pedal position signals. The dyno wiring harness is supplied with an Accelerator Pedal Position jumper cable with un-terminated pigtail leads. The test laboratory must connect two voltage command signals, Acc Pos Sensor 1 and Acc Pos Sensor 2, to the Accelerator Pedal Position jumper cable. The voltage control ranges for each signal are shown in Table 1. The wiring schematic and pin-out description for this connection is shown in Figure 8. The voltage signals must be run through a voltage isolator otherwise interference will occur between the lab DAC system and the engine ECU and throttle control will be erratic.

Command Signal	Operating Range	Min Signal (Idle)	Max Signal (WOT)
Acc Pos Sensor 1	0-5.0 VDC	0.75 VDC (15%)	4.25 VDC (85%)
Acc Pos Sensor 2	0-2.5 VDC	0.375 VDC (15%)	2.125 VDC (85%)
Note: Acc Pos Sensor 2 should always equal 50% of Acc Pos Sensor 1.			

Table 1: Accelerator Position Sensor Control Ranges

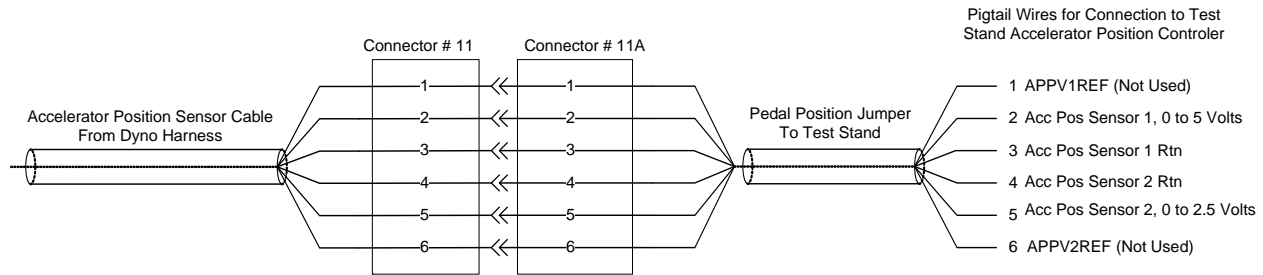

Figure 8: Accelerator Position Wiring Schematic

## 8. Engine Fluids (Supply/Discharge Systems)

8.1 Intake Air—Condition the intake air to  $(32 \pm 0.5) ^\circ\text{C}$ ,  $(11.4 \pm 0.8) \text{ g/kg}$  humidity, and pressurized to  $(0.05 \pm 0.02) \text{ kPa}$ .

8.1.1 Capacity—The supply system shall be capable of delivering 110 L/s of conditioned air, while maintaining the intake/air parameters detailed in Table 4. The test stand intake air duct system is not specified.

8.1.2 Dew Point—The dew point may be measured in the main system duct or at the test stand. If the dew point is measured in the main system duct, verify the dew point periodically at the test stand. Maintain the duct surface temperature above the dew point temperature at all points downstream of the humidity measurement point to prevent condensation and loss of humidity level.

### 8.2 Fuel and Fuel System:

8.2.1 System Description—A schematic diagram of a typical fuel supply system is shown in Fig. 1. Supply an excess volume of fuel to the fuel rail at all times. The engine has a returnless fuel system so excess fuel goes into the loop back to the heat exchanger. Deliver the fuel to a high-pressure engine driven pump that boosts the pressure and supplies the fuel to the fuel rail.

8.2.2 Controls—Maintain the fuel temperature to the fuel rail below  $50 ^\circ\text{C}$ . To ensure good atomization of the fuel, maintain the fuel pressure to the high pressure fuel pump above 413 kPa. In addition, the fuel pressure should be constant at all steady-state conditions to ensure good speed, power, and air-fuel ratio control.

8.2.3 Fuel Volume Required—Approximately 1600 L of EEE Lube cert fuel are required for each test.

8.2.4 Fuel — Obtain EEE lube cert fuel from the supplier listed in X2.1.5.

8.2.5 Laboratory Storage Tank: the tank may be filled with subsequent batches of fuel. A new batch of fuel may be added to existing fuel in the tank

8.2.6 Fuel Batch— The fuel batch that is reported for a test is the last fuel batch that was added to the tank before the test started. Each batch will be accompanied by a certificate of analysis.

### 8.3 Engine Oil:

8.3.1 Test Oil Description 8.3.1.1 The test oil sample shall be uncontaminated and representative of the lubricant formulation being evaluated.

8.3.1.2 A minimum of 7.5 L of new oil is required to complete the test. A 20 L sample of new oil is normally provided to allow for inadvertent losses.

## 9 Measurement Instrumentation

### 9.1. Temperatures

#### 9.1.1 Equipment

9.1.1.1 Temperature measurement locations for the six required temperatures are specified. Use thermocouples that are calibratable to  $0.5 ^\circ\text{C}$ . Use only OEM temperature sensors for EEC inputs.

9.1.1.2 All thermocouples, except the intake-air thermocouple, shall be premium and sheathed. The intake-air thermocouple may be an open-tip type. The diameter and length of the thermocouples shall be 3 mm by 100 mm. Thermocouples, wires, and extension wires should be matched to perform in accordance with the special limits of error as defined in ANSI MC96.1.

9.1.2 **Engine Coolant Inlet**—Install the sensor in the coolant inlet on the engine (OHTVH-008-1) perpendicular to the run. Install sensor with the tip in the center of the stream of flow. (See Fig. A2.2).

9.1.3 **Engine Coolant Outlet**—Install the sensor in the coolant outlet on the engine (OHTVH-009-1) perpendicular

to the run. Install sensor with the tip in the center of the stream of flow. (See Fig. A2.2).

9.1.4 Engine Oil Gallery—Install the tip of the sensor at the center of the flow stream in the external oil filter adapter (see Fig. A2.16) through the hole for the oil pressure switch (not used). Install a tee to accept this temperature sensor and attach the oil pressure line.

9.1.5. Engine Oil Outlet—Install the tip of the sensor at the center of the cross fitting attached to the side opposite from the engine oil gallery temperature sensor on the oil filter adaptor. The adapter needs to be modified with a 1/8 NPT hole to access the oil passage (see Fig. A2.16).

9.1.6 Intake Air— Install the tip of the thermocouple midstream in the air cleaner box downstream of the filter (see Fig. A2.12). Insertion depth shall be  $(37 \pm 2)$  mm.

9.1.8 Fuel – Install the sensor in the fuel line before the high pressure pump.

9.1.9 Air Charge – Install the sensor in the intercooler outlet tube 25+2 mm downstream from the MAPT sensor. Locate the tip at the center of the flow. (See fig A2.13)

9.1.10. Pre-intercooler – install a sensor in the tube between the turbocharger and the intercooler(See fig A2.13).

9.1.11 Exhaust – install a sensor 140+12 mm downstream on the exhaust flange (see Fig. 2.8)

9.1.12. Blowby gas – install a sensor at the gas outlet of the blowby heat exchanger

9.1.8 Calibration—Calibrate all thermocouples prior to a reference oil test. The temperature measurement system shall indicate within  $\pm 0.5$  °C of the laboratory calibration standard. The calibration standard shall be traceable to NIST.

## 9.2 Pressures:

9.2.1 Equipment—Pressure measurement for each of the eight required parameters is detailed in the following sections. This allows reasonable opportunity for adaptation of existing test stand instrumentation. However, the accuracy and resolution of the pressure measurement sensors and the complete pressure measurement system shall meet the requirements of the DACA-II document. Replace pressure sensors that are part of the EEC system with only Ford specified equipment.

NOTE 5—Tubing between the pressure tap locations and the final pressure sensors should incorporate condensate traps, as indicated by good engineering practice. This is particularly important in applications where low air pressures are transmitted by means of lines which pass through low-lying trenches between the test stand and the instrument console.

9.2.2 Manifold Absolute Pressure (MAP) – measure the manifold absolute pressure at the port downstream of the throttlebody on the front side of the intake manifold (See Fig 2.13)

9.2.3. Engine Oil - measure oil pump pressure in the external oil filter adapter (see Fig. A2.16) through the hole for the oil pressure switch (not used). Install a tee to accept the temperature sensor and attach the oil pressure line.

9.2.4 Engine Coolant Pressure—Measure engine coolant pressure at the top of the coolant reservoir as shown in Fig. A2.3.

9.2.5 Fuel – measure fuel pressure in the lower pressure fuel line at the exit of the stand fuel pump.

9.2.6. Crankcase – measure crankcase pressure at the dummy PCV valve in the cylinder block oil separator.

9.2.7 Exhaust Back Pressure - measure the exhaust back pressure with the exhaust gas sampling probe located 76+12 mm downstream of the exhaust flange (see Fig. A2.8). A sensor capable of absolute or gage measurement corrected with barometric pressure reading is recommended. Install a condensate trap between the probe and sensor to accumulate water present in the exhaust gas.

9.2.8 Inlet Air – measure inlet air pressure in the air cleaner downstream of the air filter. (See Fig A2.12)

9.2.9 Pre-Intercooler – measure the pre-intercooler pressure with the exhaust gas sampling probe located 155±25 mm downstream of the turbocharger flange (See Fig 2.13)

9.2.10 Boost (Post-Intercooler) - measure the post-intercooler pressure with the exhaust gas sampling probe located downstream of the intercooler and at least 305 mm upstream of the MAPT sensor. (See Fig 2.13)

9.2.11. Cylinder Head Oil– measure cylinder head pressure at the oil gallery plug on the left side of the cylinder head next to the belt tensioner.

9.2.10 Calibration—Calibrate all pressure measurement sensors prior to a reference oil test. The MAP pressure measurement system shall indicate within 0.1 kPa of the laboratory calibration standard. All other pressure measurement systems shall conform to the guidelines in DACA-II document. The calibration standard shall be traceable to NIST

## 9.3 Flow Rates:

9.3.1 Equipment—Flow rate measurement for each of the four required parameters is detailed in the following subsections. With the exception of the engine coolant and blowby flow rates, measurement equipment is not specified for a given parameter. This allows reasonable opportunity for adaptation of existing test stand instrumentation.

9.3.2 Engine Coolant—Determine the engine coolant flow rate using a flowmeter with an accuracy of +1% (see Fig. A2.3) Flowmeter is available from the supplier in X2.1.6. Take precautions to prevent air pockets from forming in the lines to the pressure sensor. Transparent lines or bleed lines, or both, are beneficial in this application. Ensure that the manufacturer's required for orientation and straight sections of pipe are installed immediately up and down stream of the flowmeter.

9.3.3 Blowby heat exchanger coolant—Measure the total volumetric coolant flow rate through the blowby heat exchanger system as shown in (See Fig. A2.11).

9.3.4 Fuel – measure fuel flow in kg/hr on the low pressure fuel system before the high pressure engine fuel pump.

9.3.4.1 Calibration—Calibrate the flowmeters used in the measurement of both the engine coolant flow rate and blowby heat exchanger coolant flow prior to a reference oil test. Calibrate the flowmeters as installed in the system at the test stand with test fluid. Calibrate the flowmeters with a turbine flowmeter or by a volume/time method at Stage 1 and 2 operating conditions.

9.3.5 Blowby:

9.3.5.1 Measure the blowby flow rate using the apparatus shown in Fig. 9. The measurement system routes the blowby through an external, sharp-edged orifice and into the atmosphere. Maintain crankcase pressure during operation of the system at  $(0.0 \pm 25)$  Pa to minimize the potential for crankcase leakage. Mount the orifice plate in a vertical position.

9.3.4.2 Determine the blowby flow rate by measuring the differential pressure drop across the sharp-edged orifice; an inclined manometer or differential pressure sensor is required for measurement of the differential pressure drop. The differential pressure drop sensor shall have a range from (0 to 1) kPa.

9.3.4.3 Fabricate the sharp-edged orifice assembly that is specifically designed for blowby flow rate measurement in strict compliance with the specifications that are available from the TMC. Additional information on the orifice system can be obtained from the source listed in X2.1.8 The assembly contains five orifices. The 9.525 mm orifice is generally satisfactory for the range of blowby flow rate encountered. The complete orifice assembly can also be purchased from the supplier listed in X2.1.11.

<b>ENGINE ASSEMBLY</b>	<b>A1.1</b>	
<b>Current Ford Service Part Number</b>	<b>Current Ford Engineering Part Number</b>	<b>Description</b>
<b>BB5Z-6006-A</b>	<b>BB5E-6006-AD</b>	<b>2.0L ENGINE ASY LB</b>
<b>REUSEABLE ENGINE PARTS (A1.2)</b>		
<b>Current Ford Service Part Number</b>	<b>Current Ford Engineering Part Number</b>	<b>Description</b>
<b>1S7Z6507B</b>	<b>1S7G6507D7G</b>	<b>VALVE - INLET</b>
<b>1S7Z6514AA</b>	<b>1S7G6514AE</b>	<b>RETAINER - VALVE SPRING</b>
<b>1S7Z6518AA</b>	<b>1S7G6518AD</b>	<b>KEY, VALVE SPRG</b>
<b>1S7Z8501A</b>	<b>1S7G8501BD</b>	<b>PUMP ASY - WATER</b>
<b>8W9Z6C287A</b>	<b>AG9E6C287AA</b>	<b>TAPPET ASY, FU PMP</b>
<b>AG9Z6010B</b>	<b>AG9E6010A34B</b>	<b>CYLINDER BLOCK</b>
<b>AG9Z6135B</b>	<b>AG9E6135AA</b>	<b>PIN - PISTON</b>
<b>AG9Z6140A</b>	<b>AG9G6140BA</b>	<b>RETAINER - PISTON PIN</b>
<b>AG9Z6200D</b>	<b>AG9E6200CD</b>	<b>ROD - CONNECTING</b>
<b>AG9Z6250A</b>	<b>AG9E6A268AB</b>	<b>CAMSHAFT, LH (EXHAUST)</b>
<b>AG9Z6303A</b>	<b>BB5E6300A33A</b>	<b>CRANKSHAFT ASY</b>
<b>AG9Z6505A</b>	<b>AG9E6505AA</b>	<b>VALVE - EXHAUST</b>
<b>AG9Z6600B</b>	<b>AG9E6600AB</b>	<b>PUMP ASY - OIL</b>
<b>AG9Z6A785A</b>	<b>AG9G6A785CA</b>	<b>SEPARATOR ASY - OIL</b>

AG9Z9350B	AG9E9D376AB	PUMP ASY - FUEL
AG9Z9P847A	AG9G9P847AA	BRACKET, FU INJ CLIP
BB5Z2A451C	BB5E2A451BD	PUMP ASY - VACUUM
BB5Z6019C	BB5E6019AF	COVER - CYLINDER FRONT
BB5Z6250A	BB5E6A267AB	CAMSHAFT, RH (INTAKE)
BB5Z6881A	BB5E6881AD	ADPT OIL FILTER
BB5Z6K269A	DB5E6K269AA	COUPLING - PUMP DRIVE
BB5Z9F593B	BB5E9F593BA	INJECTOR ASY
CJ5Z6049C	CJ5E6C032AC	CYLINDER HEAD ASY
CJ5Z6513A	CJ5E6513AA	SPRING - VALVE
CJ5Z6582A	CJ5E6K271BG	COVER - CYLINDER HEAD
CJ5Z6K254A	CJ5E6C271AA	TENSIONER, OIL PUMP DRIVE
CJ5Z6M280A	CJ5E6B297AA	SOLENOID - ENGINE VARIABLE TIMING
CJ5Z9D280A	CJ5E9D280BF	MANIFOLD ASY - FUEL SUPPLY
CJ5Z9D440A	CJ5E9B374BC	COVER - FUEL PUMP
CM5Z6652A	CM5E6652AA	GEAR, OIL PUMP DRIVE
CM5Z6A895A	CM5E6A895AA	CHAIN ASY - OIL PUMP DRIVE
CYFS12Y2	CB5E12405AA	SPARK PLUG
AG9Z-6108-H	AG9E-6110-AC2	PISTON- STD

Fasteners		(A1.3)	
<b>Current Ford Service Part Number</b>	<b>Current Ford Engineering Part Number</b>	<b>Description</b>	
F5TZ6A785A	F57E6A785AC	SEPARATOR ASY - OIL, EXT	
W500033S437	W500033S437	BOLT - FLANGED HEX.	
W500114S442	W500114S442	BOLT	
W500212S437	W500212S437	SCREW	
W500214S437	W500214S437	BOLT - HEX.HEAD	
W500221S437	W500221S437	BOLT - HEX.HEAD	
W500224S437	W500224S437	BOLT	
W500300S437	W500300S437	BOLT	
W500301S437	W500301S437	BOLT	
W500310S437	W500310S437	BOLT - HEX.HEAD	
W500313S437	W500313S437	BOLT	
W500328S437	W500328S437	BOLT	
W500414S442	W500414S442	BOLT	
W503275S437	W503275S437	BOLT - HEX. HEAD - FLANGED	
W505531S442	W505531S442	SCREW	
W506976S442	W506976S442	SCREW	
W520214S440	W520214S440	NUT	
W700115S437	W700115S437	SCREW AND WASHER ASY	
W701183S300	W701183S300	DOWEL - BUSH	
W701219S437	W701219S437	BOLT	
W702426S303	W702426S303	BOLT - HEX.HEAD	
W702492S437	W702492S437	STUD	
W702700S437	W702700S437	STUD	

W703383S437	W703383S437	BOLT
W703643S430	W703643S430	BOLT
W703649S300	W703649S300	PIN
W704474S437	W704474S437	STUD
W706282S430	W706282S430	BOLT
W706284S437	W706284S437	BOLT
W706487S437	W706487S437	BOLT-OIL COOLER FILTER
W711261S437	W711261S437	BOLT
W711574S439	W711574S439	STUD
W712022S430A	W712022S430	BOLT - HEX.HEAD
W713095S403	W713095S403	NUT
W715323S300	W715323S300	WASHER - COPPER, T/C OIL LINE
W715638S443	W715638S443	STUD
W715848S437	W715848S437	BOLT
W716137S437	W716137S437	BOLT
W716735S437	W716735S437	BOLT
W716841S900	W716841S900	PIN, BELL HOUSING
1L5Z6379AA	W706161S300	BOLT
1S7Z6A340AA	1S7G6K340BC	BOLT, CRK SHFT PULLEY
1S7Z6K282AA	1S7G6K282AB	BOLT, CHAIN TEN
AG9Z6065A	AG9G6065BA	BOLT - HEX.HEAD, CYL HEAD
AG9Z6345A	AG9G6345AC	BOLT - BEARING CAP - HEX. HEAD
BB5Z6214A	BB5E6214CA	BOLT - CONNECTING ROD
CV6Z6279A	CV6E6279AA	BOLT, CAMSHAFT

TEST PARTS LIST	(A1.4)	
<b>Current Ford Service Part Number</b>	<b>Current Ford Engineering Part Number</b>	<b>Description</b>
1S7Z6378AA	1S7G6378AB	WASHER,CRK DIAMOND CRUSH
AG9Z-6148-A	AG9E-6148-AA	KIT-PISTON RING
6M8Z6278A	6M8G6278AA	WASHER, CAM, DIAMOND CRUSH
7T4Z9601A	7T439601AA	ELEMENT ASY - AIR CLEANER
CJ5Z6256B	CJ5E6C524AD	SPROCKET - CAMSHAFT, LH
CJ5Z6268A	CJ5E6268AA	BELT/CHAIN - TIMING
CJ5Z6306A	CJ5E6306AB	GEAR - CRANKSHAFT
CJ5Z6C525A	CJ5E6C525AD	SPROCKET - CAMSHAFT, RH
CJ5Z6K254B	CJ5E6K254AA	TENSIONER - TIMING CHAIN
CJ5Z6K255A	CJ5E6K255AB	ARM - TIMING CHAIN TENSIONER
CJ5Z6K297A	CJ5E6K297AB	GUIDE, TIMING CHAIN

Gaskets List	(A1.5)	
<b>Current Ford Service Part Number</b>	<b>Current Ford Engineering Part Number</b>	<b>Description</b>
CJ5Z6079D	CJ5E6079AC	KIT - GASKET
1S7Z6571EA	1S7G6A517BG	SEAL - VALVE STEM EX
1S7Z6840AA	1S7G6A636AD	GASKET, OIL FILTER ADPT
1S7Z6B752AA	1S7G6B752AC	GASKET, OIL SEP
1S7Z6K301BA	1S7G6A321AA	SEAL - CRANKSHAFT REAR OIL



1S7Z8507AE	1S7G8507AF	GASKET - WATER PUMP
3M4Z6625AA	3M4G6625AA	GASKET, OIL PMP P/U TUBE
3M4Z8255A	3M4G8K530AB	GASKET, T/STAT HSG
3S4Z6571AA	3S4G6A517AA	SEAL - VALVE STEM INT
9L8Z9E936A	9L8E9E936AA	GASKET, T/B
AA5Z9E583A	AA5E9E583AA	SEAL, FU PUMP
AG9Z9P431A	AG9G9P431AA	GASKET, T/C COOL LINE
BB5Z2A572B	BB5E2D224BB	GASKET - VACUUM PUMP
BB5Z6584A	BB5E6K260AB	GASKET, CAM COVER
BB5Z6L612A	BB536L612AA	GASKET, EXHAUST
BG9Z9229A	BG9E9U509AB	KIT - "O" RING, FU INJ
BR3Z6C535B	BR3E6P251BA	SEAL - VALVE VCT
CB5Z9276A	CJ5E9A420BA	GASKET, FU PUMP CVR
CJ5Z6051A	CJ5E6051EC	GASKET - CYLINDER HEAD
CJ5Z6N652A	CJ5E6N652AA	GASKET, T/C OIL DRAIN LINE
CJ5Z8255A	CJ5E8255AA	SEAL - THERMOSTAT
CJ5Z9439A	CJ5E9439AA	GASKET - INTAKE MANIFOLD
CJ5Z9448A	CJ5E9448BA	GASKET, EX MANIFOLD
CM5Z6700A	CM5E6700AB	SEAL ASY - CRKSHAFT OIL - FRT

#### TEST STAND SET UP PARTS (A1.6)

Current Ford Service Part Number	Current Ford Engineering Part Number	Description
AG9Z9D930B	AG9T9H589BE	WIRE ASY, FE INJ
1S7Z12A699BB	1S7A12A699BB	SENSOR - ENGINE KNOCK
6M8Z6C315AA	6M8G6C315AB	SENSOR - CRANKSHAFT POSITION - CPS
8F9Z9F472A	8F9A9Y460AB	SENSOR ASY, MAF
8V2Z12B579A	8V2112B579AA	SENSOR ASY
9L8Z6G004E	9L8A6G004BC	SENSOR ASY, CYL HD TMP
AA5Z9A600B	AA539A600AD	CLEANER ASY - AIR
AE5Z6A228A	AE5Q6A228AA	PULLEY ASY - TENSION BELT
AE5Z8620A	AE5Q6C301AA	V-BELT
AG9Z6K679A	AG9G6K679BC	PIPE - OIL FEED, T/C
AG9Z6K868A	CJ5E6K868AA	VALVE ASY, ENG PST OIL COOL
AG9Z6L092A	AG9G6K677BC	HOSE - T/C OIL DRAIN
AG9Z8555A	AG9G8A506BB	HOSE - WATER INLET, T/C
AG9Z9F479A	AG919F479AB	SENSOR ASY, MAP
BV6Z9F479A	BV619F479AA	SENSOR ASY, MAPT
AS7Z6B288A	AS7112K073AA	SENSOR - CAMSHAFT POSITION
BB3Z6A642A	BB3E6A810AA	KIT ENGINE OIL COOLER
BB5Z11002C	BB5T11000AA	STARTER MOTOR ASY
BB5Z5A231A	BB535A281AA	CLAMP - HOSE, T/C TO EXH
BB5Z6C640A	BB536K863CE	CONNECTION - AIR INLET T/B END
BB5Z6C640B	BB536K863DF	CONNECTION - AIR INLET, I/C END
BB5Z6C646C	BB536C646CD	DUCT - AIR, TURBO END
BB5Z6C646D	BB536C646DF	DUCT - AIR, INTERCOOLER END

<b>BB5Z6C683A</b>	BB5E6L663AA	<b>FILTER ASY (T/C SCREEN)</b>
<b>BB5Z9647A</b>	BB539647AB	<b>BRACKET, AIRBOX</b>
<b>BB5Z9661A</b>	BB539643AA	<b>COVER, AIRBOX</b>
<b>BB5Z9B659B</b>	BB539F805DE	<b>HOSE - AIR, TURBO END</b>
<b>BB5Z9B659E</b>	BB539F805CG	<b>HOSE - AIR, AIR BOX END</b>
<b>BM5Z9F972A</b>	BM5G9F972BA	<b>SENSOR - FUEL INJECTOR PRESSURE</b>
<b>BR2Z9E499A</b>	BR2E9E499AA	<b>CONNECTOR, VAC CONTRL, T/C</b>
<b>CB5Z6K682F</b>	CB5E6K682BF	<b>TURBO CHARGER</b>
<b>CB5Z8592A</b>	CB5E8592AB	<b>CONNECTION - WATER OUT, T/C</b>
<b>CB5Z8K153B</b>	CB5E8B535AC	<b>TUBE - WATER OUTLET</b>
<b>CB5Z9424D</b>	CB5E9424AF	<b>MANIFOLD ASY - INTAKE</b>
<b>CB5Z9S468C</b>	CB5E9S468AF	<b>HOSE, EMS (VAC HARNESS)</b>
<b>CJ5Z9J323B</b>	CJ5E9J323BC	<b>TUBE ASY FE PMP TO FE MAN</b>
<b>CM5Z12029A</b>	CM5E12A366CA	<b>COIL ASY - IGNITION</b>
<b>CP9Z9E926A</b>	CM5E9F991AD	<b>THROTTLE BODY AND MOTOR ASY</b>
<b>D4ZZ7600A</b>	D4ZA7120AB	<b>SLEEVE, PILOT BEARING</b>
<b>DU5Z12A581U</b>	DU5T12C508UE	<b>WIRE ASY, ENGINE MAIN</b>
<b>YS4Z6766A</b>	YS4G6766DA	<b>CAP ASY - OIL FILLER</b>
<b>5M6Z8509AE</b>	5M6Q8509AE	<b>PULLEY - WATER PUMP</b>
<b>AG9Z6312B</b>	AG9E6D334AA	<b>PULLEY - CRANKSHAFT</b>

<b>SPECIAL PARTS</b>	<b>(A1.7)</b>
<b>PART NUMBER</b>	<b>DESCRIPTION</b>
OHTVH-002-1	PAN, OIL MODIFIED, ASSY.(INCLUDING DIPSTICK AND PICK UP TUBE)
VH002-2	TUBE, PICK UP
OHTVH-005-1	HOUSING, FLYWHEEL
OHTVH-006-1	FLYWHEEL, MODIFIED, 2.0L
VH006-8	CLUTCH, ASSY. W/ PRESSURE PLATE
VH006-8-1	CLUTCH
VH006-8-2	PLATE, PRESSURE
OHTVH-007-1	HARNESS, DYNO, 2.0L
OHTVH-008-1	INLET, COOLANT
VH008-1	CLIP, RETAINER, SENSOR, COOLANT INLET
VH008-2	SEAL, COOLANT INLET
OHTVH-009-1	OUTLET, COOLANT
VH009-6	SEAL, COOLANT OUTLET
OHTVH-011-1	SHIM, CLUTCH PRESSURE PLATE
	CFM BALANCE SHAFT DELETE KIT

CHAIN MEASUREMENT RIG PARTS (A1.8)					
Description	Quantity	Manufacturer	Mfg PN	suggested Supplier	Supplier PN
PUSH PIN FOR END CAP	6	80/20	3274		
PC DATA INPUT DEVICE	1	MITUTOYO	264-012-10	CLEVELAND SPECIALTY INSPECTION SERVICES, INC.	264-012-10
SPC CABLE	1	MITUTOYO	905338	CLEVELAND SPECIALTY INSPECTION SERVICES, INC.	905338
MITUTOYO ELECTRONIC DIAL INDICATOR	1	MITUTOYO	543-792	MSC	60777216
CLAMP	1	DESTACO	609-B	MSC	90968736
BEARING, FOR GEARS	2	NICE	3016DCT NTG18	FASTENAL	4194269
PILLOW BLOCK BEARING, SPB12	4	THOMPSON	SPB12	GRAINGER	2HXW8
SHAFTS 24 IN	2	THOMPSON	QS 3/4 L 24	GRAINGER	5JW62
T-NUT, SLIDE-IN, OFFSET, 80/20 3278	69	80/20	3278		
BRACKET, 4-HOLE, CORNER, 80/20, 4301	14	80/20	4301		
BRACKET, 2-HOLE, CORNER, 80/20, 4302	4	80/20	4302		
END CAP, 1515 LITE, 80/20, 2030	6	80/20	2030		
CRANKSHAFT GEAR, MODIFIED	2	FORD	CJ5Z-6306-A	MARSHALL FORD	CJ5Z-6306-A
NEODYMIUM DISC MAGNET, 1/4" DIAMETER, 1/4" THICK, 2.5 LBS. MAXIMUM PULL	4			MCMASTER	58605K35
NEODYMIUM DISC MAGNET, 3/8" DIAMETER, 1/8" THICK, 3 LBS. MAXIMUM PULL	1			MCMASTER	5862K95
MAGNETIC SWITCH	2			MCMASTER	65985K14
ROUND BUMPER, RUBBER, 1-1/2" DIAMETER, 5/16" DIAMETER HOLE, WITH WASHER	4			MCMASTER	9540K756
PARKER MPE SERIES 60 MM FRAME 2 STACK SERVO MOTOR WITH 2500 LINE ENCODER	1	PARKER	MPE0602 A4E-KC1N	PARKER	MPE0602A 4E-KC1N
PARKER ARIES 750 WATT SERVO DRIVE WITH CONTROLLER (REQUIRES PROGRAMMING)	1	PARKER	AR-08CE	PARKER	AR-08CE
PARKER MPE TO ARIES 25 FOOT POWER CABLE	1	PARKER	71-030630-25	PARKER	71-030630-25
PARKER MPE TO ARIES 25 FOOT FEEDBACK CABLE	1	PARKER	71-030631-25	PARKER	71-030631-25
3.5MM AUDIO CABLE	1				

Annex A2

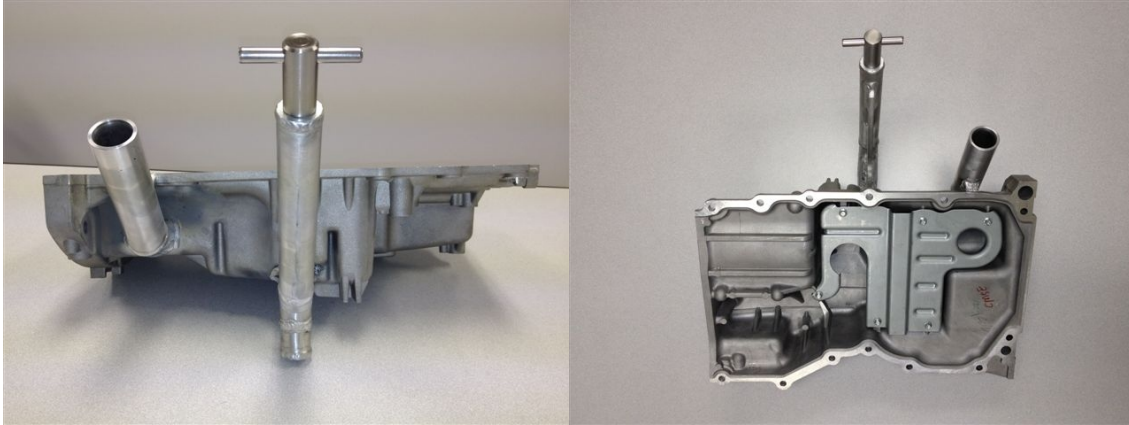

Oil pan  
Figure A2.1

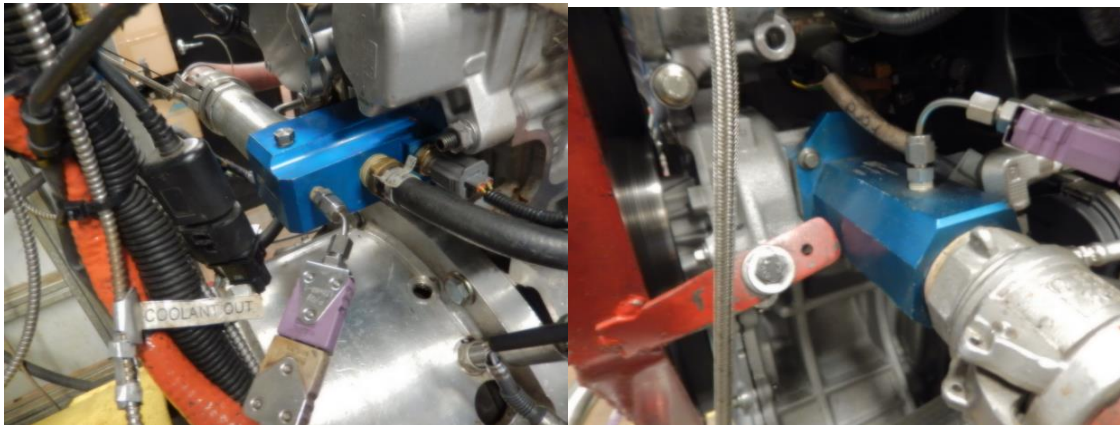

Coolant out

Coolant in

Coolant in and out connections and thermocouple locations  
FIG. A2.2

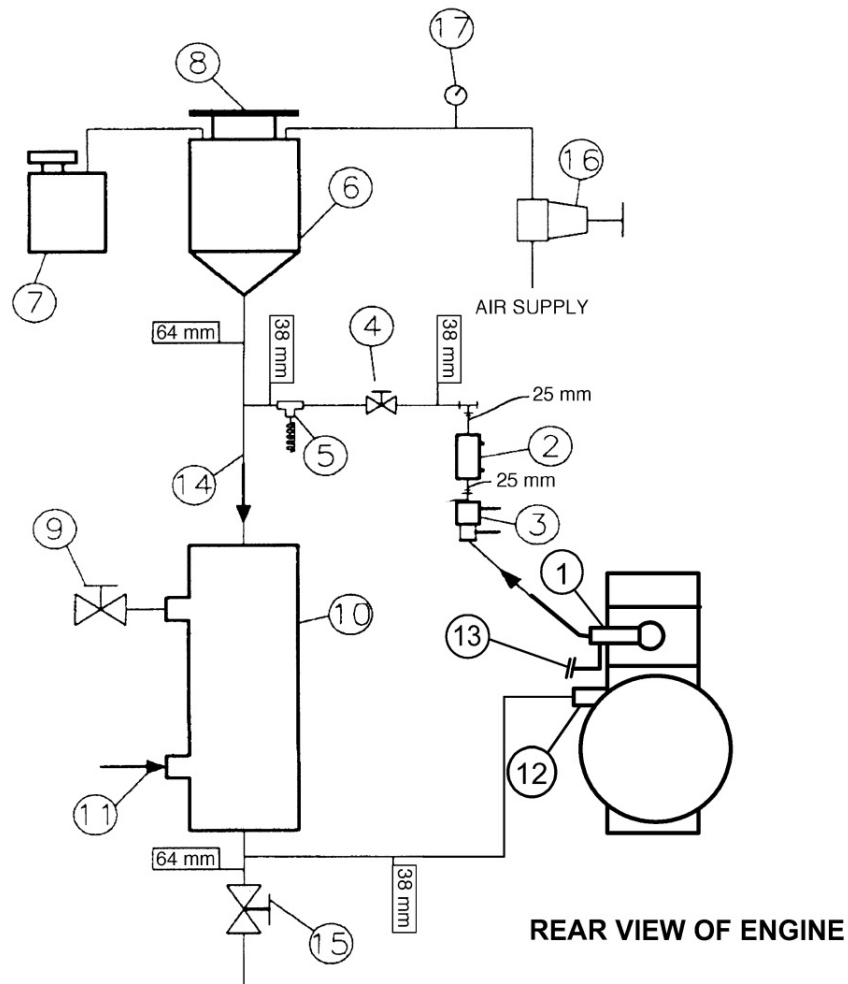

NOTE 1—Observe temperature sensor locations in thermostat housing and at water pump inlet.

NOTE 2—Components of Engine Cooling System—

- (1) Thermostat housing, coolant out with temperature sensor (OHTVH-009-1)
- (2) Sight glass
- (3) Flowmeter
- (4) Flow control valve
- (5) Optional temperature sensor
- (6) Fabricated coolant reservoir
- (7) Constant full expansion tank
- (8) Pressure radiator cap (MOTORCRAFT RS40 P/N D2YY-8100-A)
- (9) Process water control valve (regulated by temperature controller with three remote set points)
- (10) Heat exchanger (ITT Standard P/N 5-030-06-048-001 TYP.)
- (11) Process water supply (shell side)
- (12) Water pump inlet with temperature sensor (OHTVH-008-1)
- (13) Turbocharger coolant return
- (14) Engine coolant (tube side)
- (15) Coolant system drain valve
- (16) Coolant pressure regulator
- (17) Coolant pressure gage

FIG. A2.3 Typical Engine Cooling System Schematic



Figure A2.4: Motor mounts, front

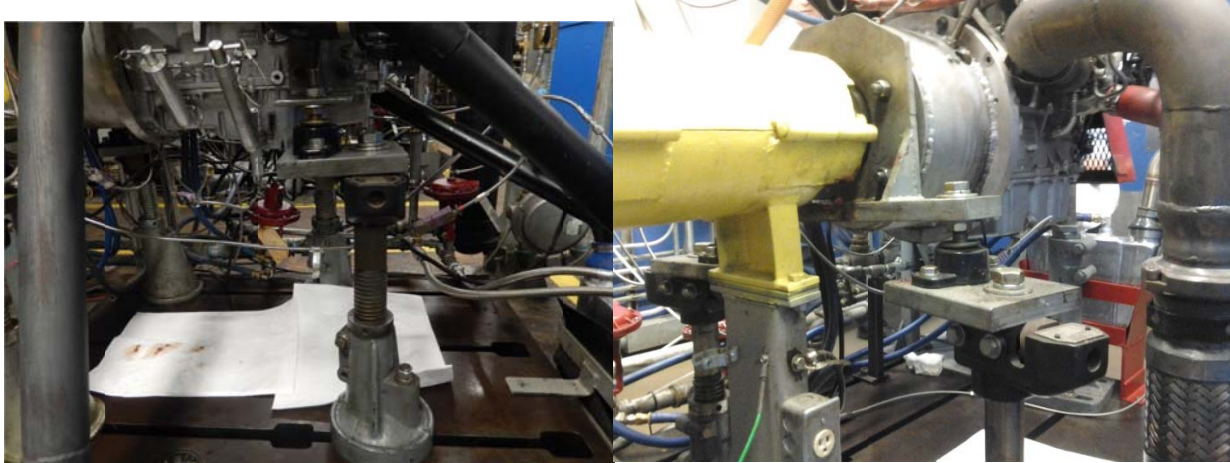

Figure A2.5: Motor mounts, rear

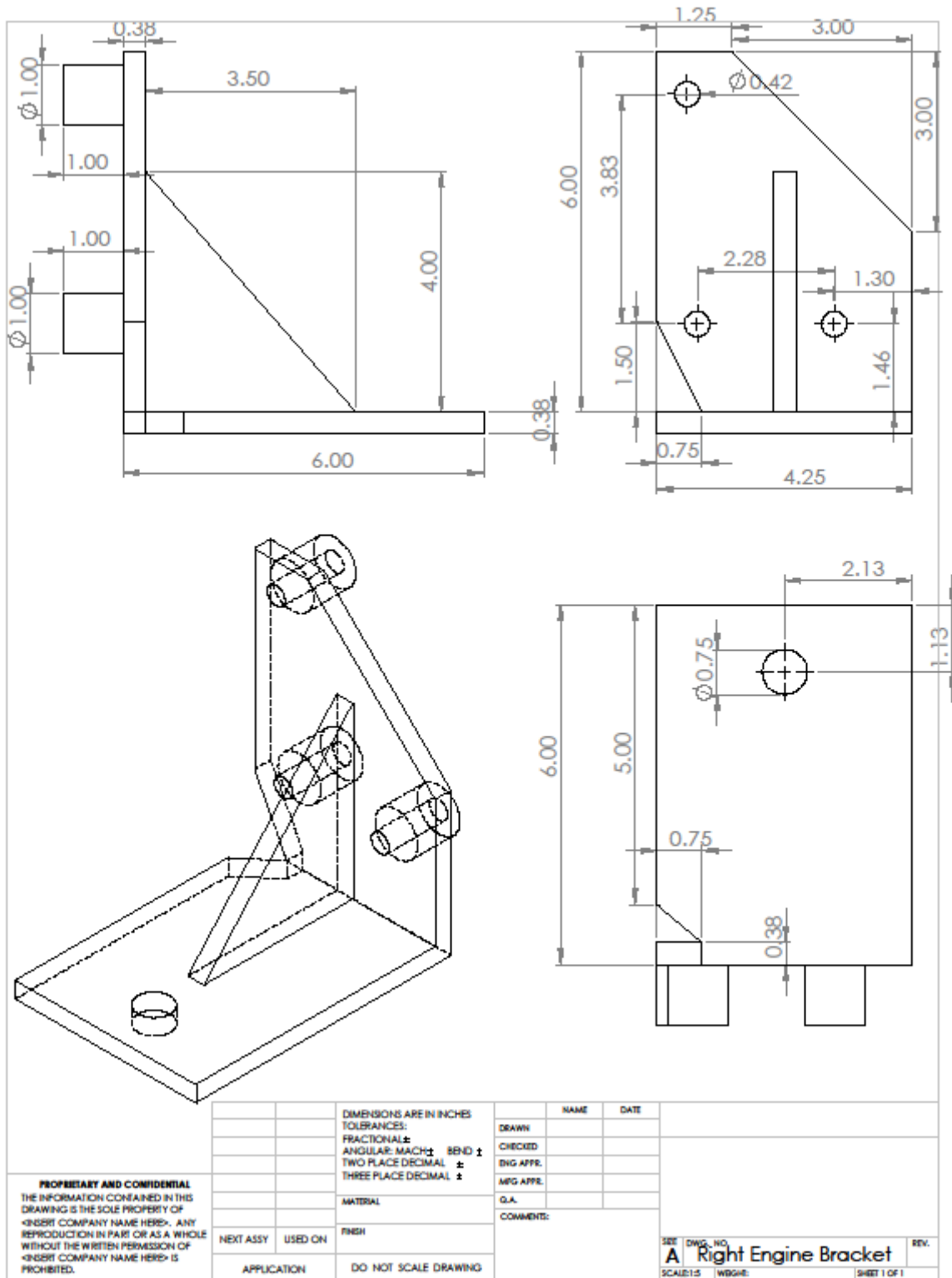

Figure A2.6 Front Mount Bracket

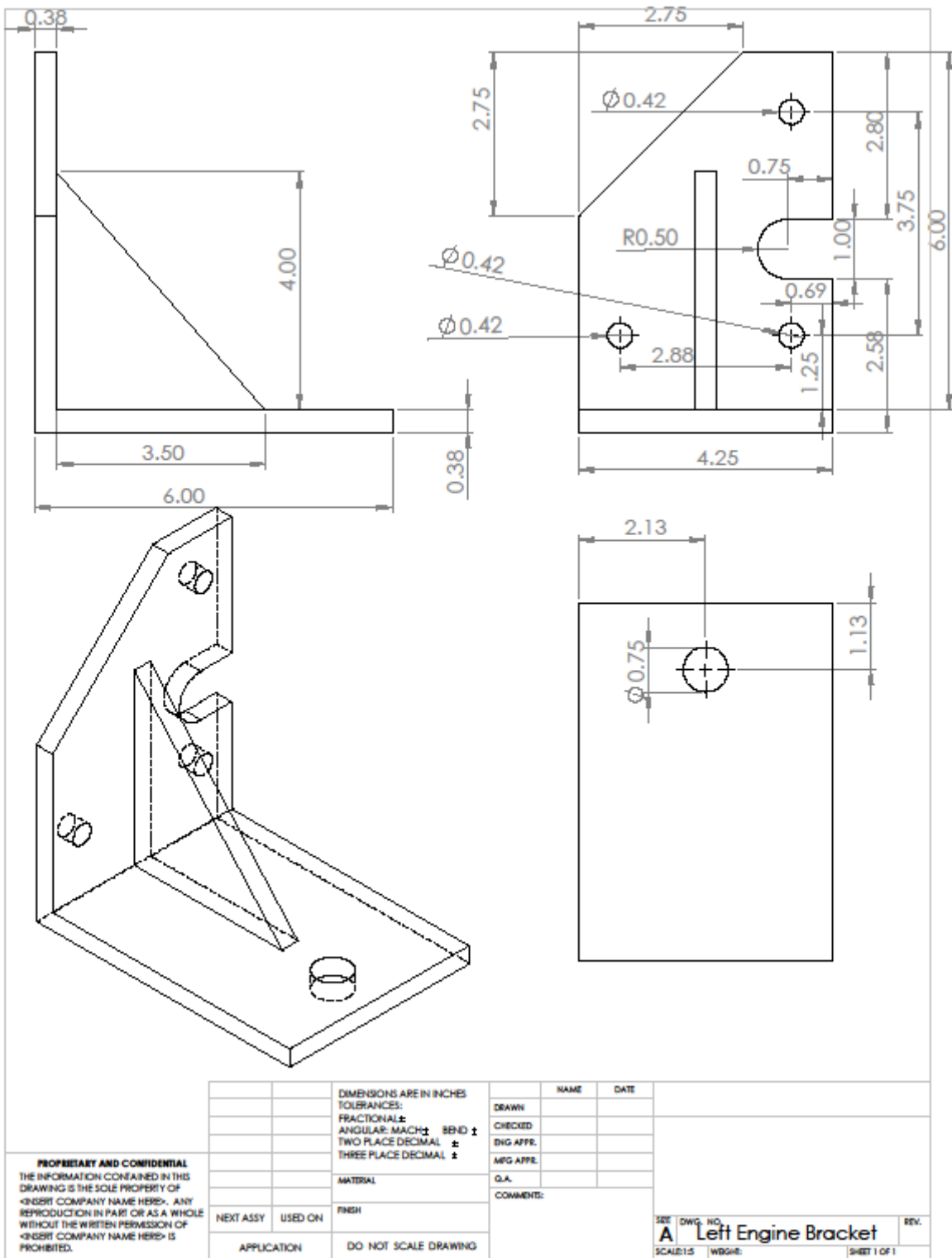

Figure A2.7 Front Mount Bracket



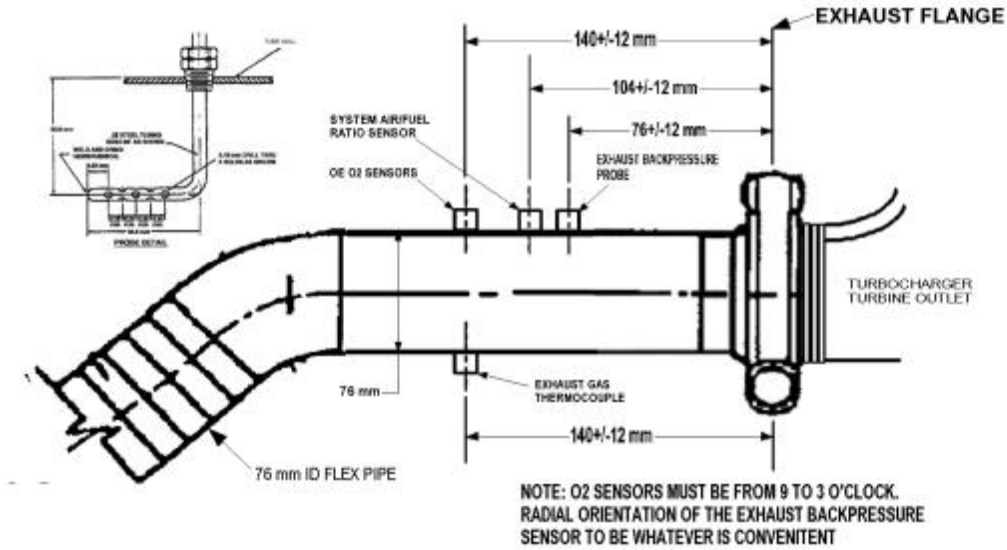
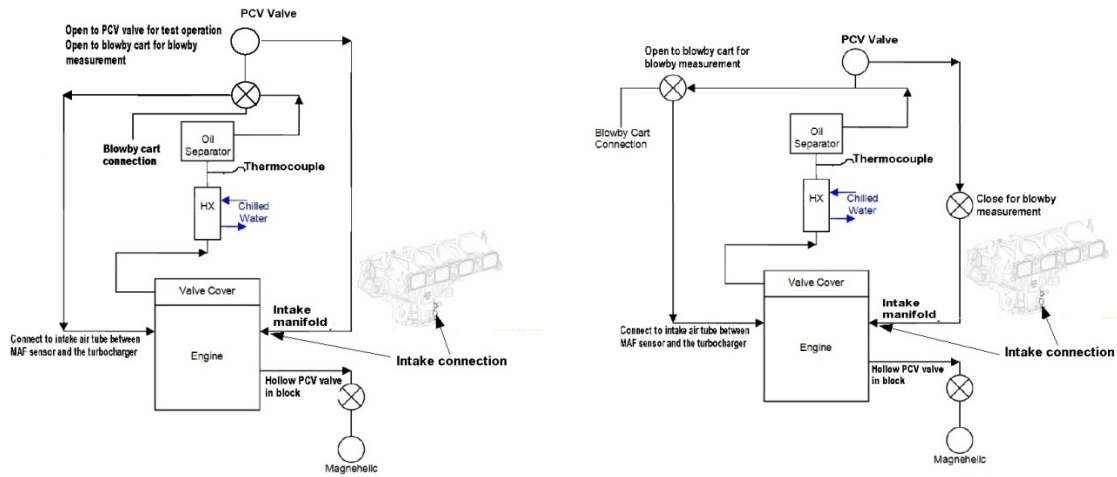

Figure A2.8: Exhaust Measurements and Instrumentation



3-way valve connection

2-way valve connection

Figure A2.9: Crankcase Ventilation System

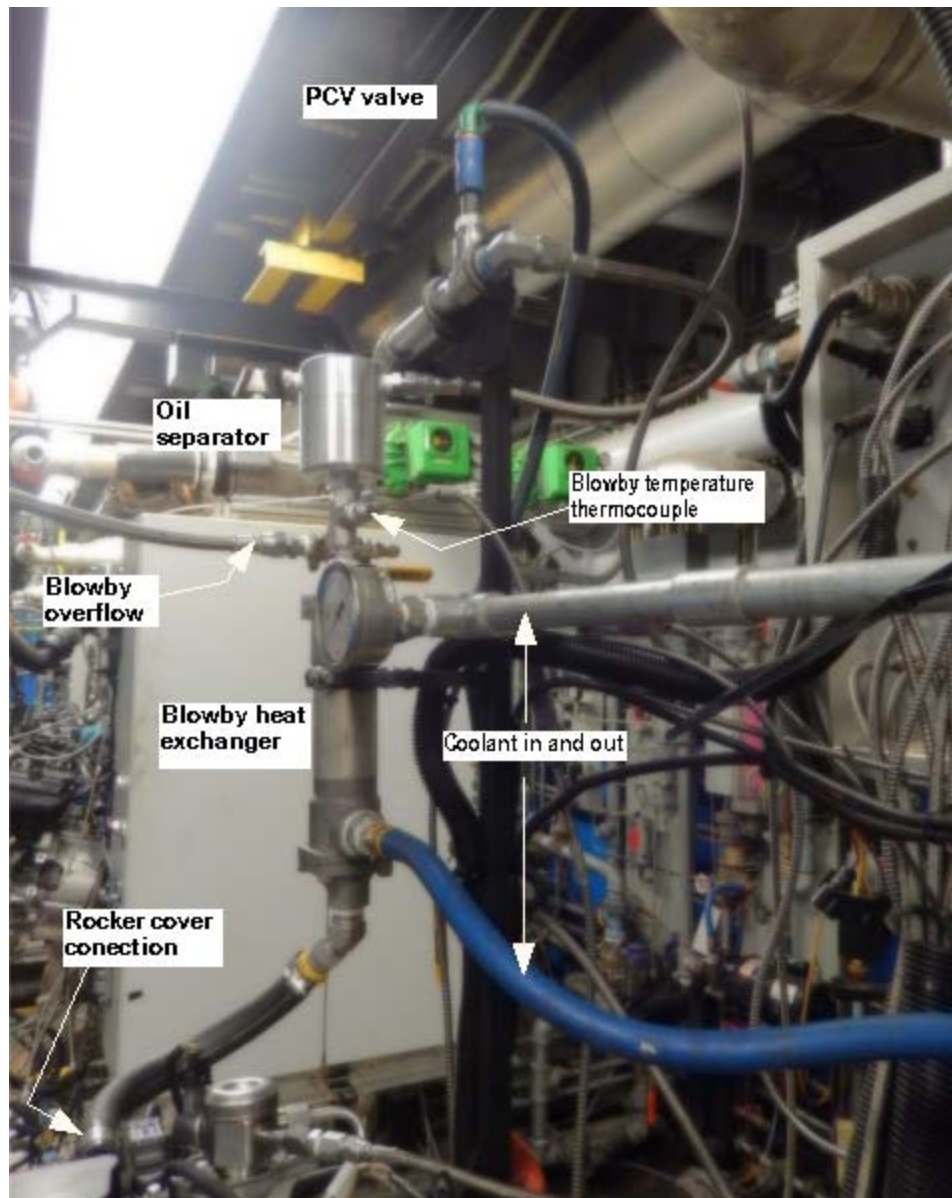
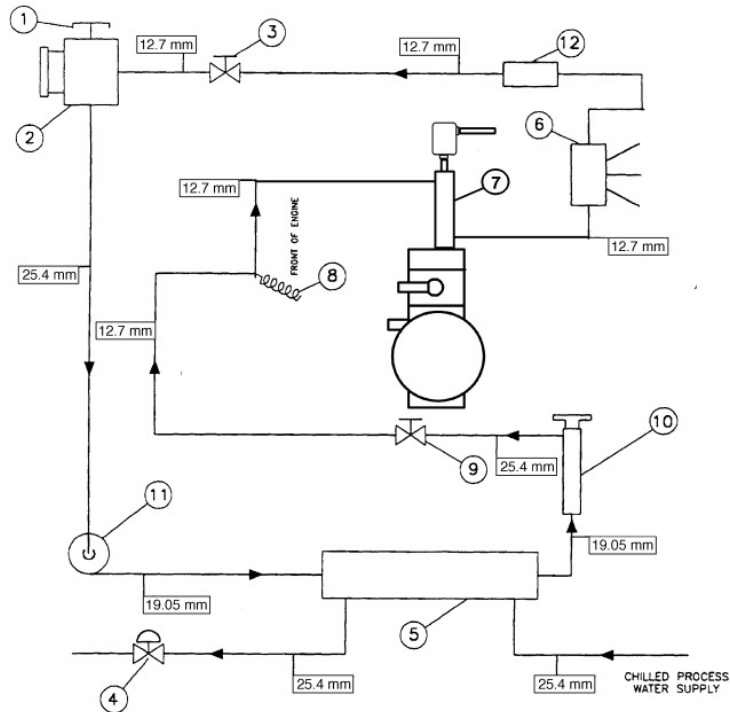

Figure A2.10: Crankcase Ventilation System



**Legend**

- (1) Vented reservoir cap
- (2) Coolant reservoir (fabricated)
- (3) Pressure control valve (optional)
- (4) Chilled process water control valve
- (5) System heat exchanger
- (6) F and P Co. flowrator tube, FF-1-35-G-10/448D053U06
- (7) CCV Heat Exchanger
- (8) Inlet temperature sensor
- (9) Flow control valve
- (10) External heat source
- (11) Electric coolant pump DAYTON 6K581A
- (12) ABB Kent-Taylor flow element, 1330LZ08000-8375A

FIG. 2.11 Typical CCV Heat Exchanger Heating and Cooling System



FIG. A2.12 Typical air intake system

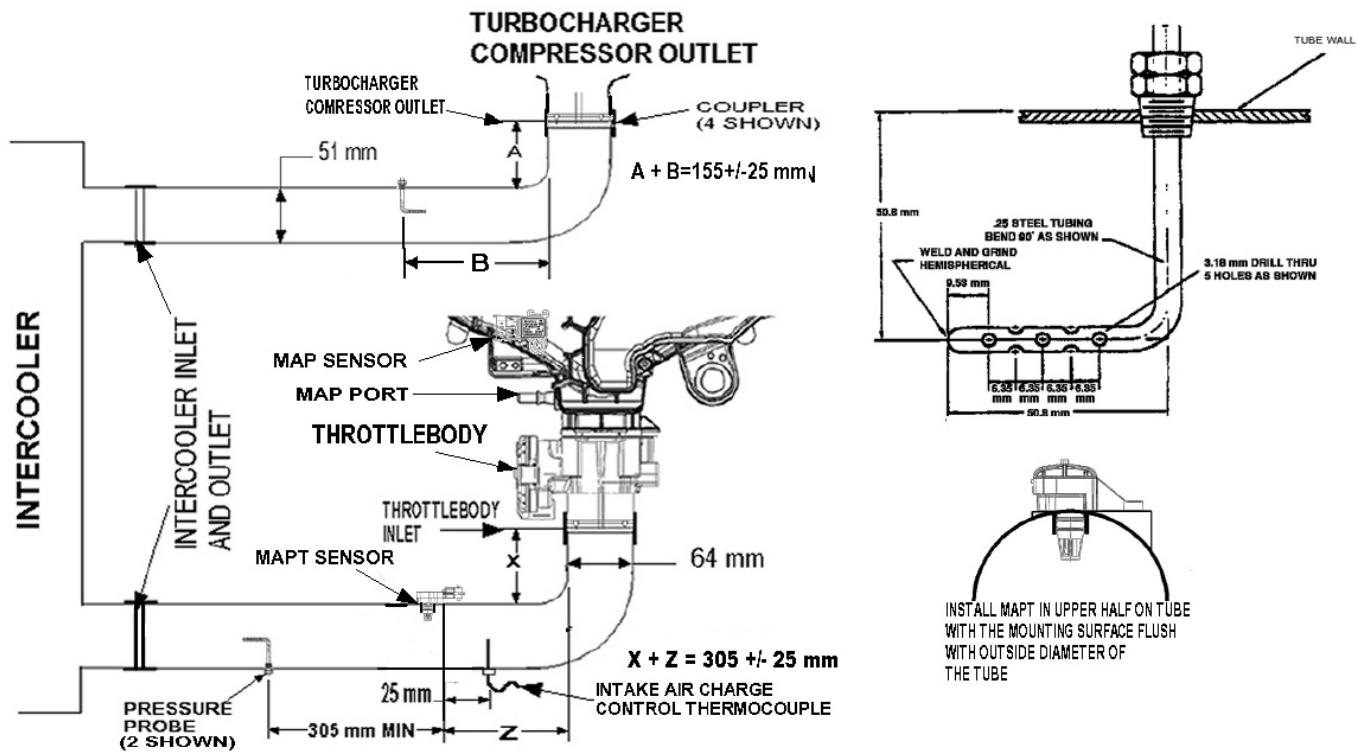

Figure A2.13: Intercooler Tubing Measurements and Instrumentation

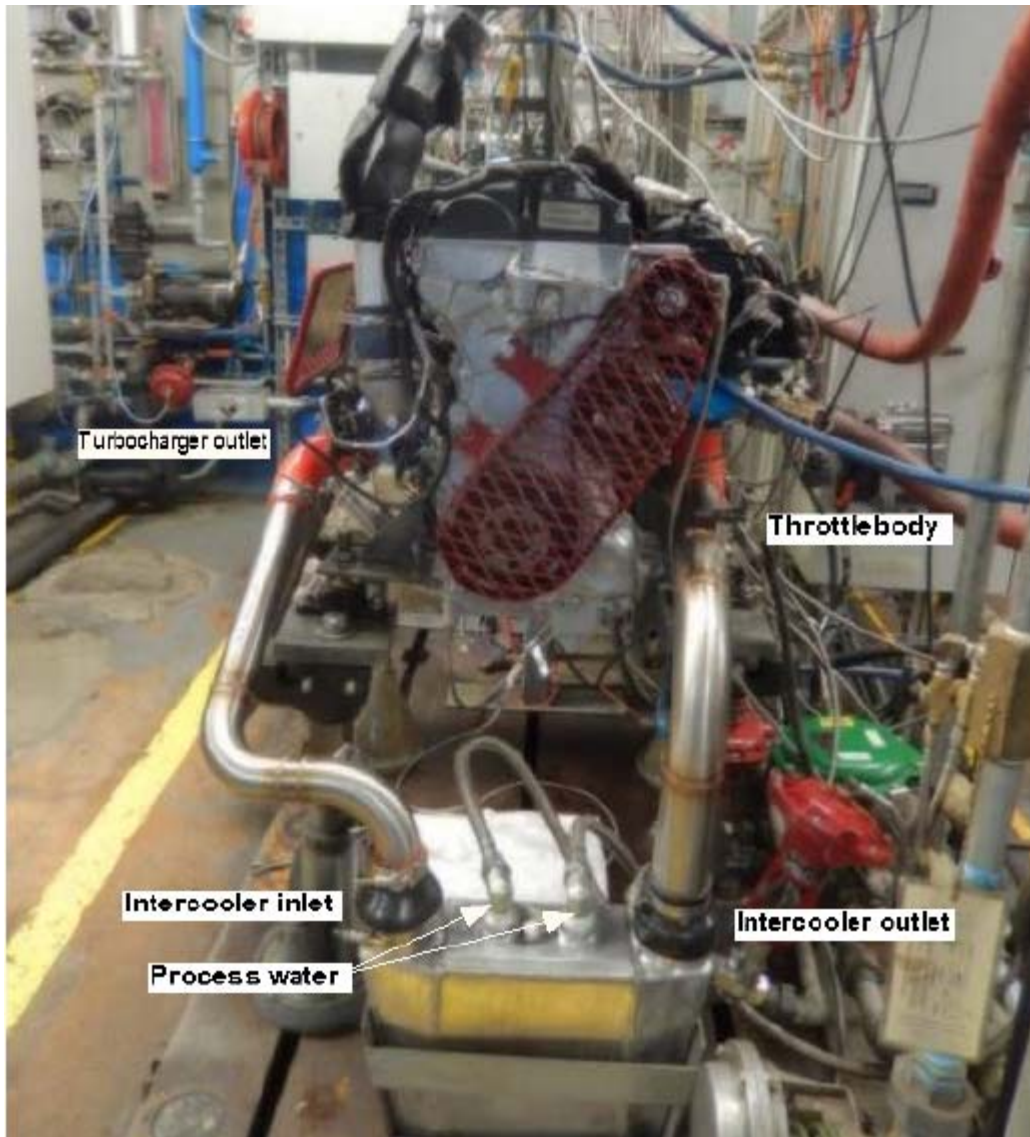

Figure A2.14 Typical intercooler installation



Figure A2.15 Oil cooler showing oil gallery pressure location

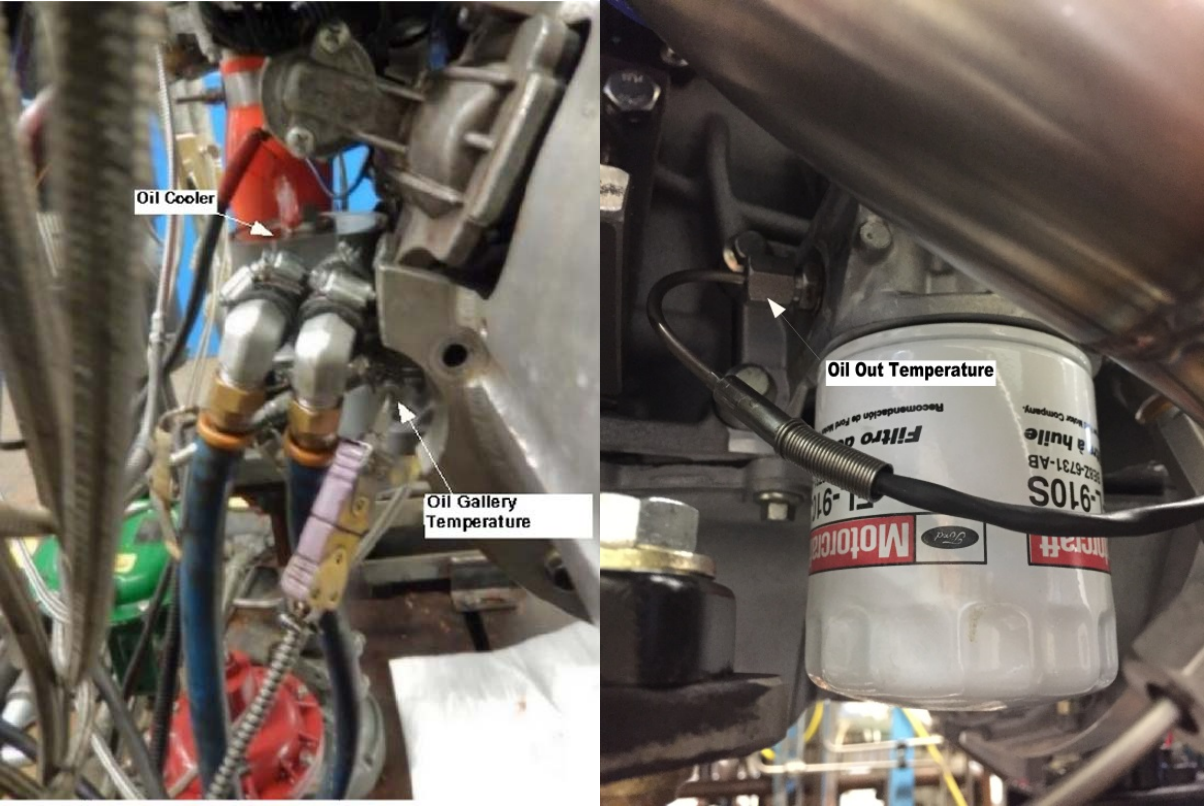
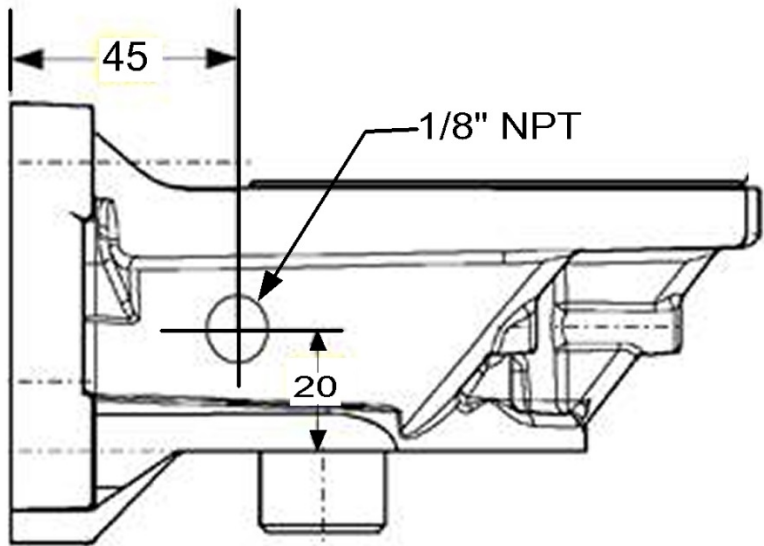

Figure A2.16 Oil cooler showing oil temperature locations



Oil Out temperature location in oil filter adapter (Dimensions in mm)

Figure A2.16 Oil cooler showing oil temperature locations



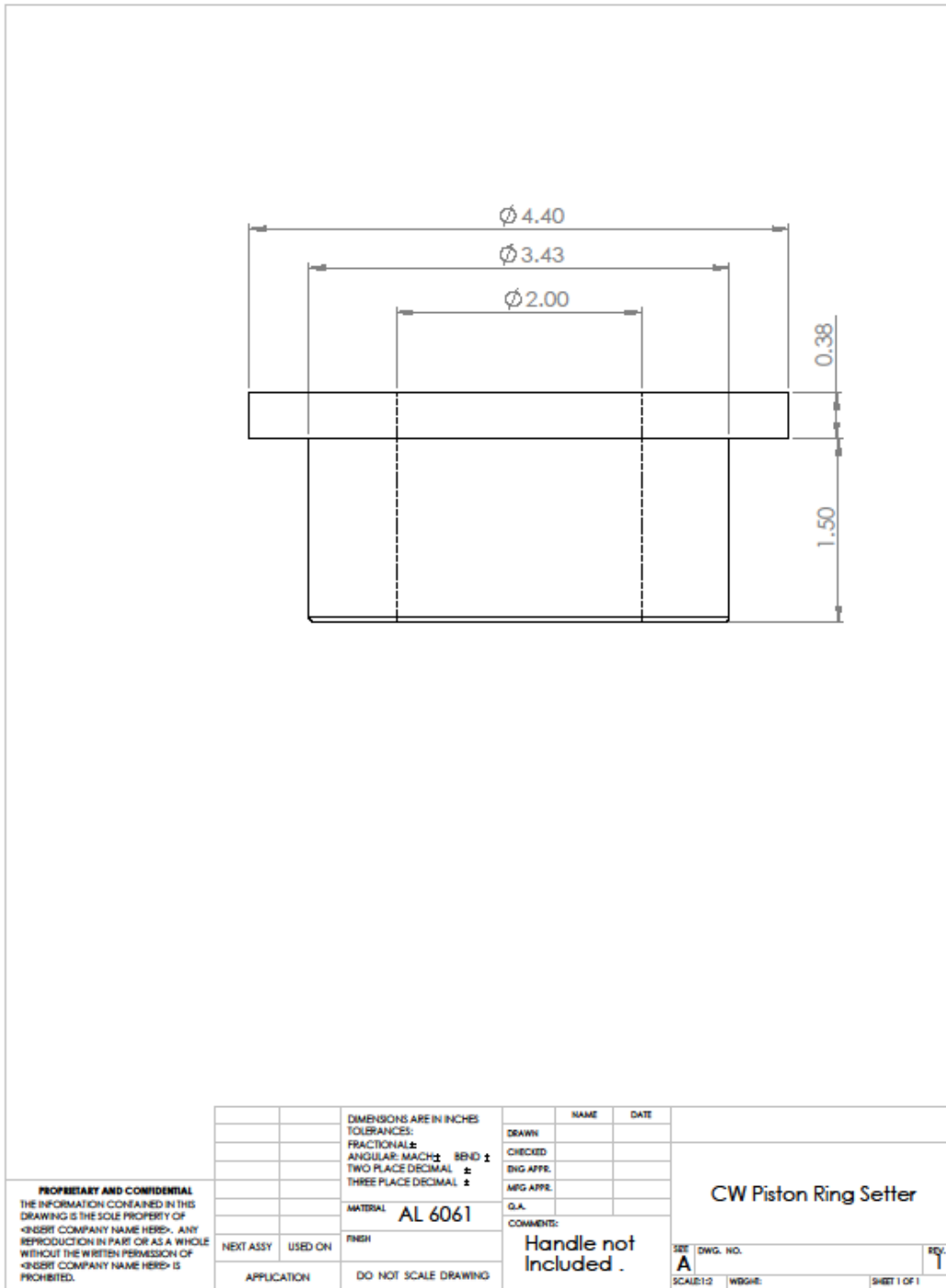

Figure A2.17

Bore Ladder

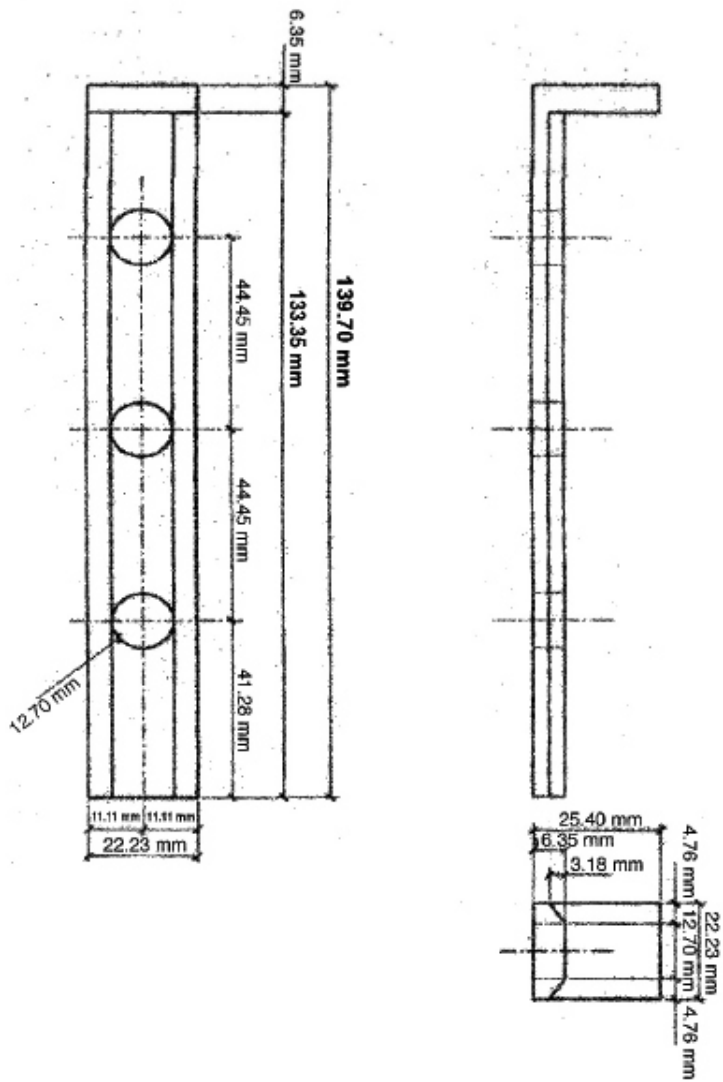
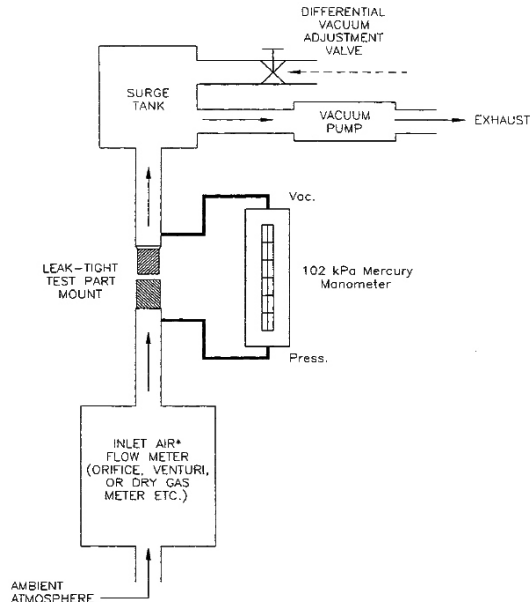

Figure A2.18  
Bore Ladder





NOTE 1—The inlet flow meter must calibrate to within 5 % of the standard (pre-calibrated) orifices at the pressure differentials stamped on the orifices.

FIG. A2.22 PCV Valve Flow Test Apparatus

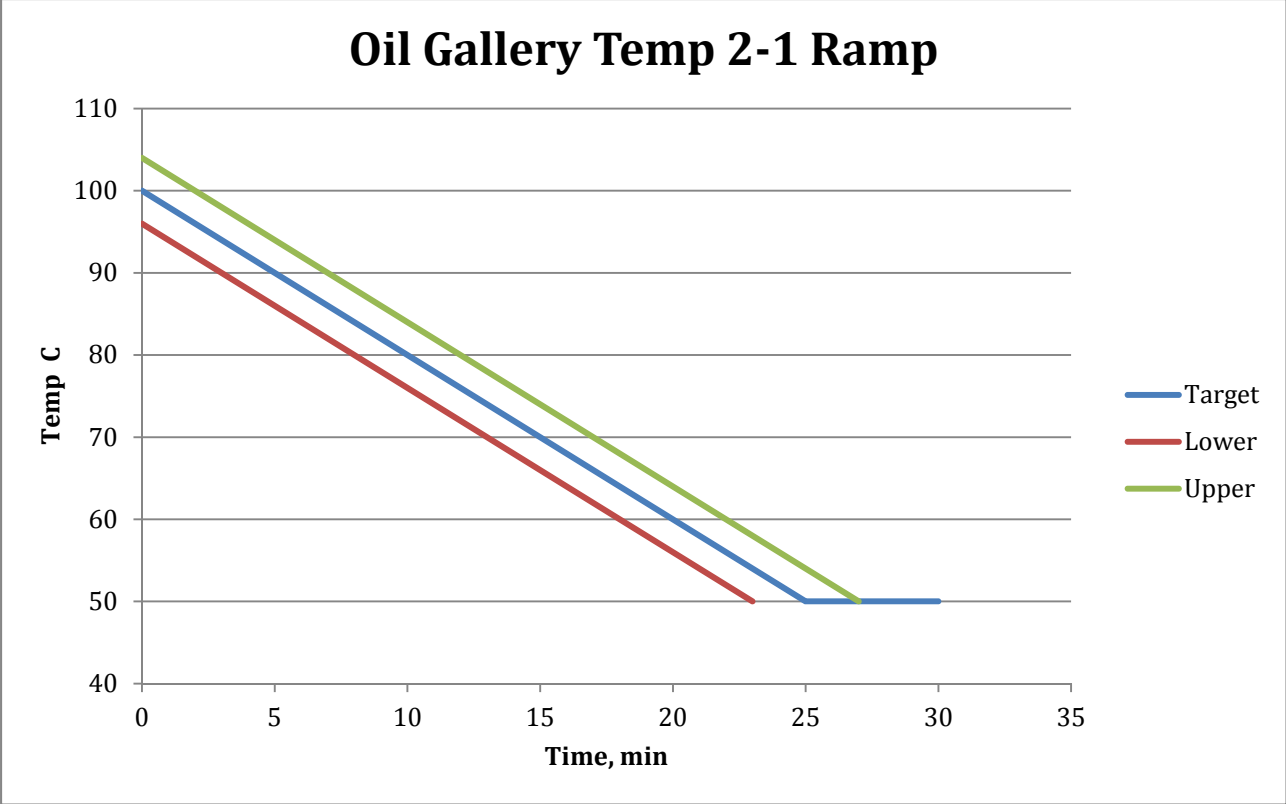
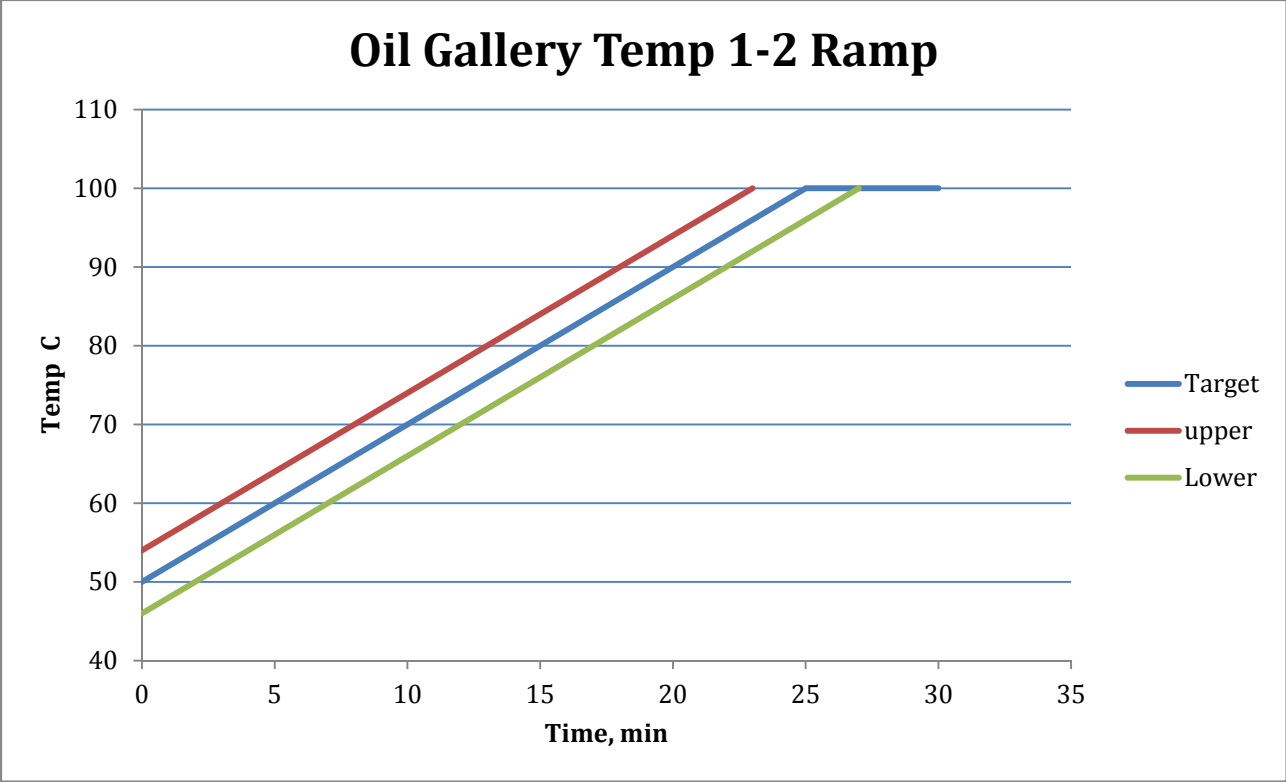

Typical Torque and temperature ramps  
Figure A2.23

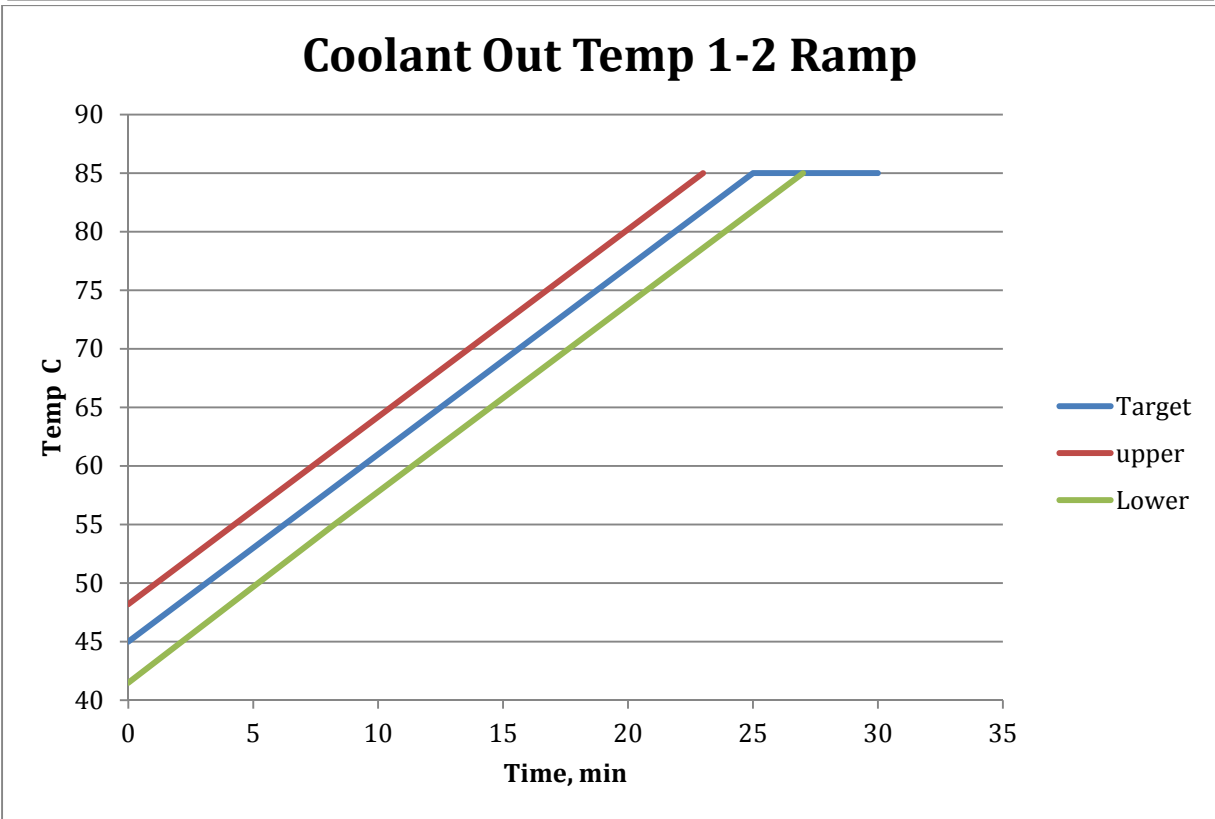
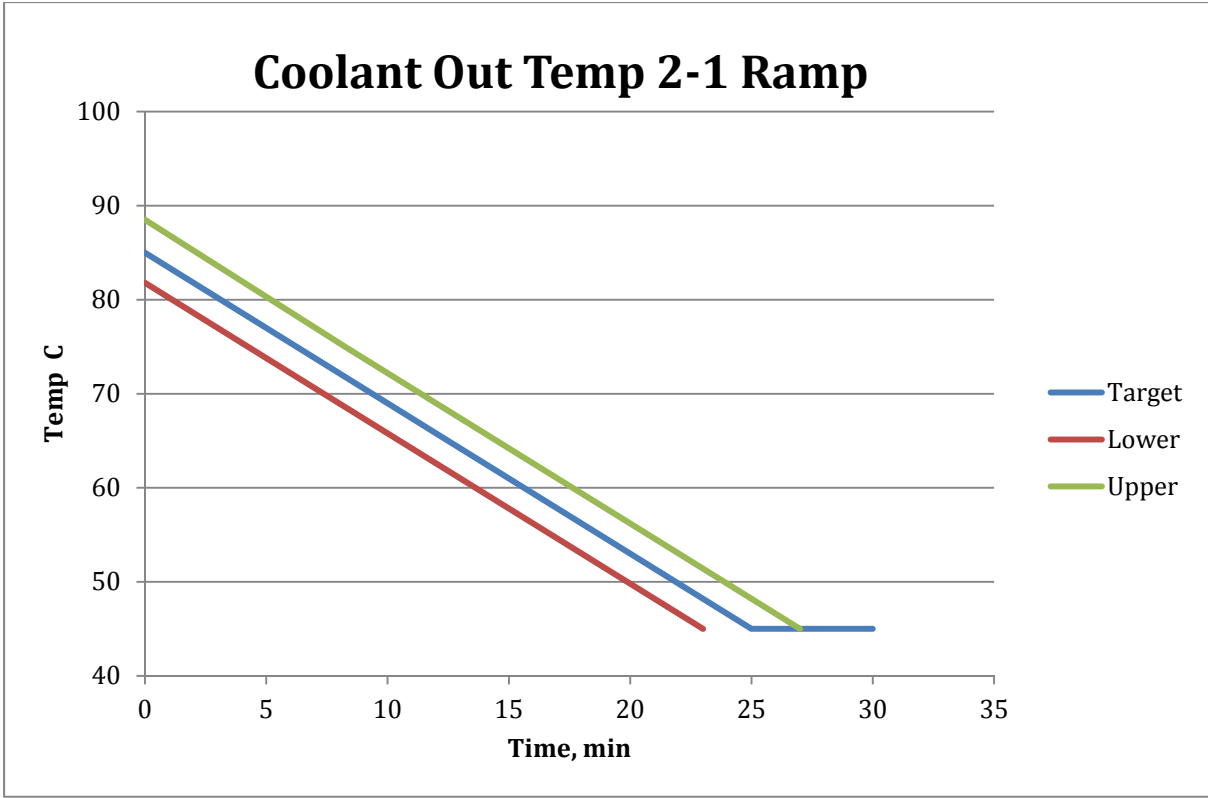

Typical Torque and temperature ramps  
Figure A2.23 (cont)

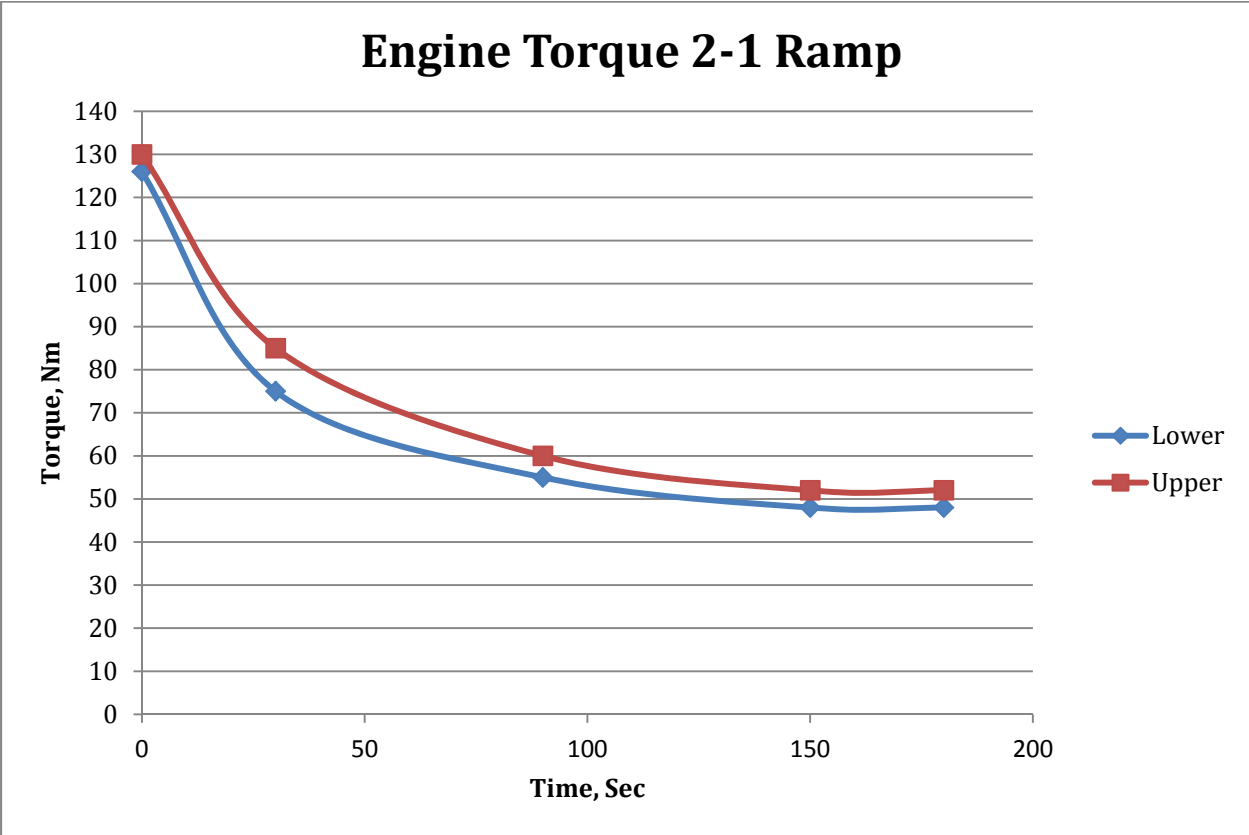
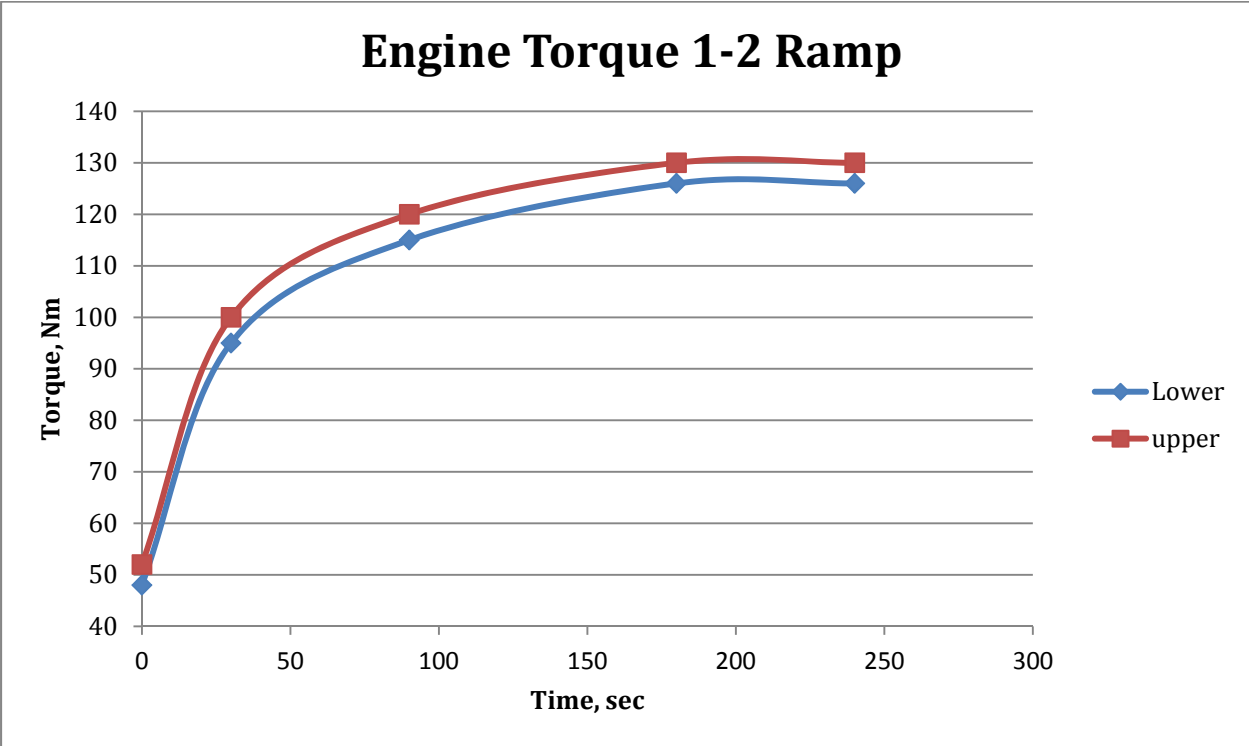

Typical Torque and temperature ramps  
Figure A2.23 (cont)

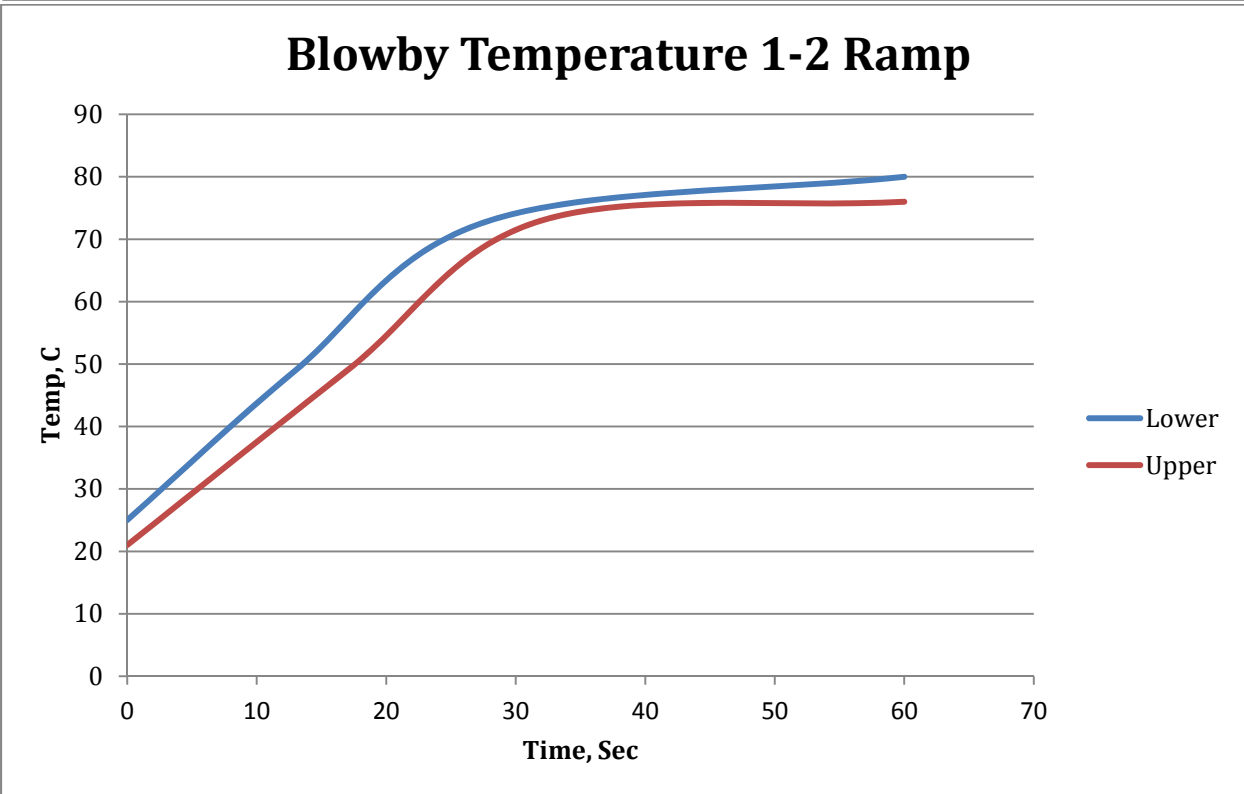
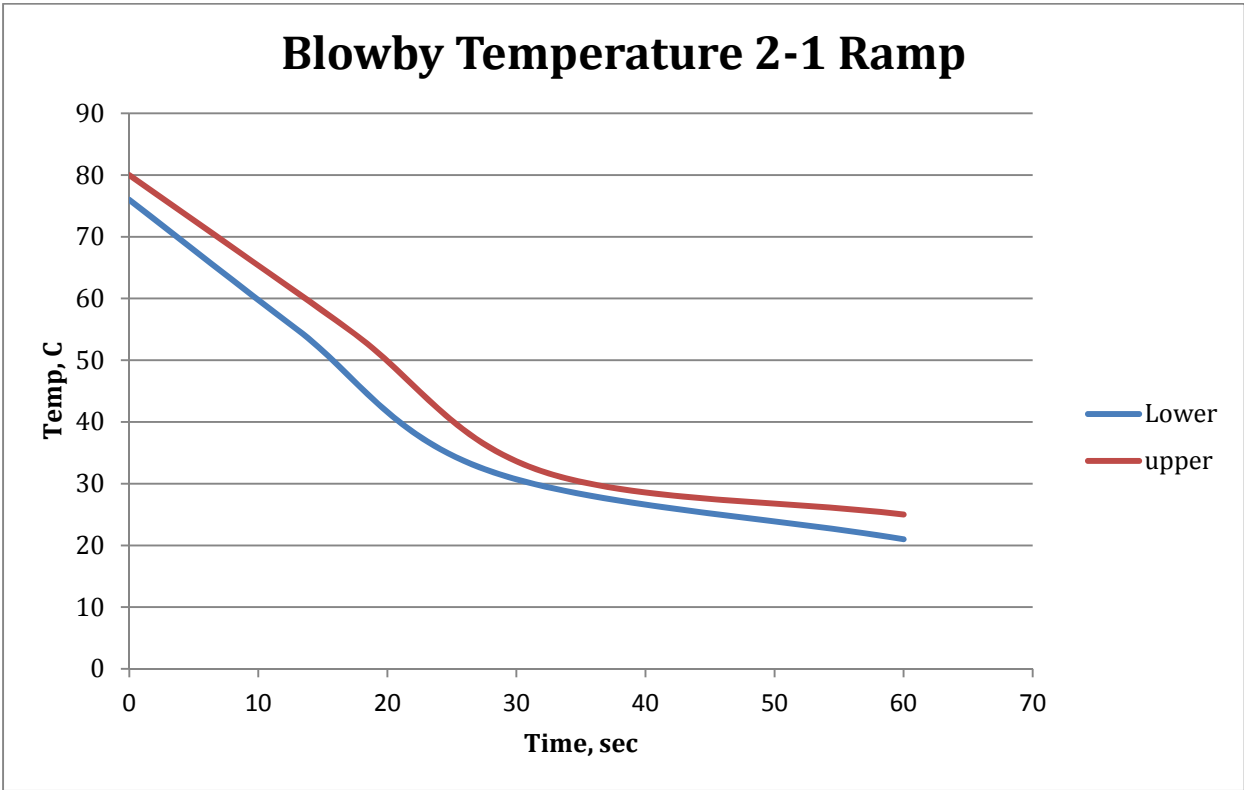

Typical Torque and temperature ramps  
Figure A2.23 (cont)



## CW HEAD DATA SHEET

**HEAD #** \_\_\_\_\_  
**HEAD RUN #** \_\_\_\_\_  
**DATE:** \_\_\_\_\_

**Engine #** \_\_\_\_\_  
**Test #** \_\_\_\_\_  
**Instrument Cntrl # (Valve Guide)** \_\_\_\_\_  
**Instrument Cntrl # (Valve Stem)** \_\_\_\_\_

	Valve Guide Diameter (5.51) mm	Valve Stem Diameter (5.5) mm	Clearance (0.03-0.07) mm
1A Intake			°.0
1B Intake			°.0
2A Intake			°.0
2B Intake			°.0
3A Intake			°.0
3B Intake			°.0
4A Intake			°.0
4B Intake			°.0

	Valve Guide Diameter (5.51) mm	Valve Stem Diameter (5.5) mm	Clearance (0.03-0.07) mm
1A Exhaust			°.0
1B Exhaust			°.0
2A Exhaust			°.0
2B Exhaust			°.0
3A Exhaust			°.0
3B Exhaust			°.0
4A Exhaust			°.0
4B Exhaust			°.0

**Instrument Cntrl # (Length)**

**Instrument Cntrl # (Tension)**

	SPRING FREE LENGTH (47mm)	SPRING TENSION (@28.5 mm)
1A Intake		Kilos
1B Intake		Kilos
2A Intake		Kilos
2B Intake		Kilos
3A Intake		Kilos
3B Intake		Kilos
4A Intake		Kilos
4B Intake		Kilos

	SPRING FREE LENGTH (47mm)	SPRING TENSION (@28.5 mm)
1A Exhaust		Kilos
1B Exhaust		Kilos
2A Exhaust		Kilos
2B Exhaust		Kilos
3A Exhaust		Kilos
3B Exhaust		Kilos
4A Exhaust		Kilos
4B Exhaust		Kilos

**Instrument Cntrl # (Lash)**

Intake Valve Lash Measurement	
(.19 - .31) mm	
1F	
1R	
2F	
2R	
3F	
3R	
4F	
4R	

Exhaust Valve Lash Measurement	
(.30 - .42) mm	
1F	
1R	
2F	
2R	
3F	
3R	
4F	
4R	

**Head Flatness:** \_\_\_\_\_

**Initials:** \_\_\_\_\_

Cylinder Head Build Data Sheet  
Figure A2.24

## CW Cylinder Bore Measurement Record

Block # / Run # : \_\_\_\_\_ / \_\_\_\_\_  
 Test Number: \_\_\_\_\_

Date: \_\_\_\_\_  
 Tech: \_\_\_\_\_

### Cylinder Bore Measurements w/o Stress Plate

Finish Target: ( 9- 13 Ra )  $\mu$ in  
 Bore Gauge Set: 87.5 mm

Piston to Wall Clearance: (.0225 - .0475 ) mm  
 Cylinder Cross Hatch Target: ( 25°-35° ) Deg

#### Instrument Cntrl # \_\_\_\_\_

Cylinder Number	Location	Longitudinal Diameter ( mm )	Transverse Diameter ( mm )
	Top	87	87
1	Middle	87	87
	Bottom	87	87
	Top	87	87
2	Middle	87	87
	Bottom	87	87
	Top	87	87
3	Middle	87	87
	Bottom	87	87
	Top	87	87
4	Middle	87	87
	Bottom	87	87

#### Instrument Cntrl # \_\_\_\_\_

Surface Finish ( $\mu$ in )	Piston Diameter ( mm )	Piston Clearance ( mm )
	87	87
	87	87
	87	87
	87	87
	87	87
	87	87
	87	87
	87	87
	87	87
	87	87
	87	87
	87	87

#### Instrument Cntrl # \_\_\_\_\_

Cylinder Number	Top Ring Gap	Second Ring Gap
1		
2		
3		
4		

#### REGAP/EOT

Cylinder Number	Top Ring Gap	Second Ring Gap
1		
2		
3		
4		

Approved \_\_\_\_\_

Effective Date: 07/09/15

Page 1 of 1

Cylinder Bore Measurement Record  
 Figure A2.25

**CW Engine Measurement Record**

Engine Number: \_\_\_\_\_ Date: \_\_\_\_\_

Test Number: \_\_\_\_\_ Technician: \_\_\_\_\_

Instrument Cntrl # (Journal) \_\_\_\_\_ Instrument Cntrl # (Bearing) \_\_\_\_\_

Main Bearing Journals (mm)				
<i>Diameter: (51.978mm - 52.002mm)</i>				
Journal Number	Horizontal Diameter	Vertical Diameter	Bearing Inside Diameter	Clearance .027mm - .052mm
1				
2				
3				
4				
5				

Instrument Cntrl # (Journal) \_\_\_\_\_ Instrument Cntrl # (Bearing) \_\_\_\_\_

Rod Bearing Journals (mm)				
<i>Diameter: (51.978mm - 52.002mm)</i>				
Journal Number	Horizontal Diameter	Vertical Diameter	Bearing Inside Diameter	Clearance .027mm - .052mm
1				
2				
3				
4				

Instrument Cntrl # (Endplay) \_\_\_\_\_

Crankshaft End Play (0.22 mm - 0.45 mm) \_\_\_\_\_

Engine Bearing Measurement Record  
Figure A2.26

### A3. CONTROL AND DATA ACQUISITION REQUIREMENTS

**A3.1 General Description:**

A3.1.1 The data acquisition system shall be capable of logging the operational data in digital format. It is to the advantage of the laboratory that the system be capable of real time plotting of controlled parameters to help assess test validity. The systems shall be capable of calculating real time quality index as this will be monitored throughout the test as designated in **A2.5**.

A3.1.2 Control capability is not dictated by this procedure. The control system shall be capable of keeping the controlled parameters within the limits specified in **Table 4** (see 12.2.3 ) and maintain the quality index shown in **A2.5**.

A3.1.3 Design the control and data acquisition system to meet the requirements listed below. Use the recommendations laid out in the Instrumentation Task Force Report and Data Acquisition Task Force Report for any items not addressed in **Annex A2**.

**A3.2 Digital Recording Frequency**—The maximum allowable time period over which data can be accumulated is one second. This data can be filtered, as described in **A2.6**, and will be considered a reading.

**A3.3 Steady State Operation:**

A3.3.1 This portion of the test will be the entire time at Stage 1 and 2 conditions. Stage 1 and 2 conditions are reached by the end of the ramping periods. Calculate the quality index using values reported to the accuracy levels in **Table A2.1**.

**TABLE A3.1 Accuracy Levels of Data Points to be Used in QI Calculations**

Parameter	Field Length
Speed	
Humidity	
Temperature	
Torque	
Intake Air Pressure	
Exhaust Backpressure	
Coolant Outlet Pressure	
Coolant Flow	

**TABLE A3.2 L and U Constants and Over and Under-Range Values**

Parameter	Stages	L	U	Over-Range	Under-Range
Coolflow	1				
Cooloutt	1				
	2				
Exhbprs	1				
	2				
Humidity	1, 2				
Intairpr	1, 2				
Intairt	1, 2				
Oilint	1				
	2				
Speed	1				
	3				
Torque	1				
	2				
Cooloutp	1, 2				
BBint	1				
	2				

---

**TABLE A3.3 Maximum Allowable Time Constants**

---

Control Parameter	Time Constant, s
Engine speed, r/min	0.5
Torque, Nm	0.7
Engine oil Gallery, °C	2.4
Engine coolant out, °C	2.4
Engine coolant flow, L/min	8.0
Blowby in, °C	2.4
Intake, air, °C	2.4
Intake air press, kPa	1.2
Exhaust back pressure, kPa	1.2
Engine coolant pressure	1.2

---

A3.3.2 The time intervals between recorded readings shall not exceed 1 min. Data shall be recorded throughout the length of each stage.

A2.4 *Transitions* :

A3.4.1 The ramp requirements are listed in 12.2.3.3, Table 5.

A3.4.2 During the transition, the time intervals between all recorded readings shall not exceed 2 seconds..

A3.5 *Quality Index*:

TBD

A3.6 *Time Constants*:

A3.6.1 Filtering can be applied to all control parameters. The amount of filtering applied shall not allow time constants to exceed the values listed in **Table A2.3**. This time constant shall pertain to the entire system, running from the sensor to the display and data acquisition.

A3.6.2 Maximum allowable system time constants for the controlled parameters are shown in **Table A3.3**

A9.1 Test Engine Parts—The required parts for use in the Chain wear test procedure are for the 2.0L GTDI engine which are supplied by the test sponsor (Ford Motor Company) through Ford Component Sales:

Ford Motor Co.

290 Town Center Dr

Dearborn, MI 48126

A9.2 Various Materials—

Oil pan and baffles,

Oil screen,

Flywheel

Clutch, pressureplate, spacer, bellhousing

Dynamometer and engine wire harnesses

Are available from the following supplier:

OH Technologies

9300 Progress Pkwy.

Mentor, OH 44060

A9.3 Various Materials—

Are available from the following supplier:

Test Engineering, Inc.

12758 Cimarron Path, Ste. 102

San Antonio, TX 78249-3417

A9.4 Oil separator

Moroso Part number 85487

Are available from the following supplier:  
American Muscle  
Summit Racing

A9.5 Type 5 or Type 52 intercooler from [www.frozenboost.com](http://www.frozenboost.com)

A9.6 Chain Measurement Apparatus, MCMR 1000, can be obtained from Lubrizol Corp, attn.: Geroge Szappanos, (440) 347-2352, [George.Szappanos@lubrizol.com](mailto:George.Szappanos@lubrizol.com)

A9.8 Powertrain Control Module are available from Ford Motor Company, attn.: Ron Romano, 313-845-4068, [rromano@ford.com](mailto:rromano@ford.com)

## Annex X

### X1. ENGINE MEASUREMENT RECORD FORMS

X1.1 The necessary engine measurement record forms are shown in Figs. A2.24 – A2.26.

### X2. SOURCES OF MATERIALS AND INFORMATION

X2.1 The following sources are provided for convenience only. This does not represent an exclusive or complete listing of required materials or information sources.

X2.1.1 Test Engine Parts— Chain wear test parts can be purchased through Ford Component Sales and Ford or Lincoln dealers:

Ford Motor Co.  
290 Town Center Dr  
Dearborn, MI 48126

X2.1.2 ASTM Test Monitoring Center—All communications with the TMC should be directed as follows:

ASTM Test Monitoring Center  
6555 Penn Ave.  
Pittsburgh, PA 15206-4489

X2.1.3 Test Sponsor—All communications with the test sponsor (Ford Motor Co.) should be directed as follows:

Ford Motor Company  
Diagnostic Service Center II  
1800 Fairlane Drive,  
Room 410  
Allen Park, MI 48101

X2.1.4 Aeroquip Hose and Fittings—Aeroquip hose and fittings can be obtained from the following supplier:

Aeroquip Corp.  
1225 W. Main  
Van Wert, OH 45891

X2.1.5 Fuel Information and Availability—General information concerning EEE fuel, including availability, can be obtained from the following:

Haltermann Products  
1201 S. Sheldon Rd.  
P.O. Box 249  
Channelview, TX 79530-0429

X2.1.6 Flowmeter coolant

X2.1.7 Intake-Air Humidity Instruments—The Alnor Dewpointer, EG & G, Foxboro, Hy-Cal, General Eastern and

Protimeter dewpoint meters are suitable for measurement of the intake-air specific humidity.

X2.1.9 Heat Exchangers—ITT Standard Heat Exchangers can be obtained from the following supplier:  
Kinetics Engineering Corp.  
2055 Silber Road, Suite 101  
Houston, TX 77055

X2.1.10 Fuel Flow Measurement—Mass fuel flowmeters are available from the following supplier:  
Micro Motion Corp.  
7070 Winchester Circle  
Boulder, CO 80301

X2.1.12 Parts Washer and Chemicals—A dishwasher type parts cleaner and associated chemicals can be obtained from the following supplier:  
Better Engineering Manufacturing  
8361 Town Court Center  
Baltimore, MD 21236-4964

X2.1.13 Crankcase and Intake—Air Pressure Gages—Gages are available from the following supplier:  
Dwyer Instrument Co.  
Junction of Indiana State Highway 212 and U.S. Highway 12  
P.O. Box 373  
Michigan City, IN 46360

X2.1.14 Blowby Heat Exchanger Coolant—Nacool 2000 Engine Cooling System Treatment is available from the following supplier:  
Nalco Chemical Co. Functional Chemicals Group  
One Nalco Ctr.  
Naperville, IL 60566-1024

X2.1.15 Lubricants—EF-411 is available from local distributors of ExxonMobil products.

X2.1.16 Tygon Hose—Tygon hose is available through local Cadillac Plastic Co. distributors or the following supplier:  
The Norton Co.  
12 East Avenue  
Tallmadge, OH 44278

X2.1.17 Special Tools for the Test Engine—Special tools to facilitate assembly and disassembly of the engine are available from the following supplier:  
Owatonna Tool Co.  
2013 4th St.  
NW Owatonna, MN 55060

X2.1.18; : Tierra Tech model MOT500NS ultrasonic parts cleaner or similar Tierra Tech ultrasonic parts cleaner can be obtained from Tierra Tech

X2.1.19: Tierra Tech Ultrasonic solution 7 and B cleaner can be obtained from Tierra Tech

X2.1.20: Flex Hone Model: GB33432 can be obtained from Granger

X2.1.21: Pneumatic Honing Drill, Westward 1/2 Reversible Air Drill, Model: 5ZL26G can be obtained from Granger

X2.1.22: Penmul L460 can be obtained from Penetone Corp., P.O. Box 22006, Los Angeles, CA 90022

X2.1.23: Parts Cleaning Soap, (NAT-50 or PDN-50) known to the committee at this time is Better Engineering Manufacturing, 8361 Town Court, Baltimore, MD 21236.

X2.1.24: Hatchview Software (<http://digitalmetrology.myshopify.com/products/hatchview>)

X2.1.25: USB microscope.

X2.1.26: The sole source of supply of the Sanford Piston Ring Grinder known to the committee at this time is

Sanford Mfg. Co., 300 Cox St., P.O. Box 318, Roselle, NJ 07203.

X2.1.27: The sole source of supply of the 3/16 in. carbide ring cutting burr, No. 74010020 known to the committee at this time is M. A. Ford.

X2.1.28: The sole source of supply of Sunnen soft stone, No. JHU-820 known to the committee at this time is Sunnen, Inc., 7910 Manchester, St. Louis, MO 63143.

X2.1.29: Ford camshaft alignment tool (Ford P/N 303-1565) can be obtained from a Ford or Lincoln dealer

X2.1.30: Crankshaft TDC timing peg (Ford P/N 303-507)

X2.1.31: CFM Balance Shaft Delete Kit (Part number 1-0180).

X2.1.32 Dyne Systems, Inc. • W209 N17391 Industrial Drive • Jackson, WI 53037 USA • 800-657-0726

Dyno One, Inc. 14671 N 250 W Edinburg, IN 46124 info@dyno-one.com

Tel 812-526-0500

Fax 812-526-7465

X2.1.33: Quicksilver part# 6628-A

X2.1.34: Chemtool B12

## 12. Test Procedure

### 12.1 Pre-test Procedure:

12.1.1 *Engine Break-In Procedure*—Run break-in schedule listed in **Table 2**. Conduct the break-in before each test using the supplied test oil. The break in procedure has 12 steps and is 8.25hrs long. There are 30 second ramps between steps that are counted as part of the 8.25hrs. The engine is flushed during the break-in procedure. There are a total of 3 oil flushes as shown in **Table 2**; the oil is drained for 15 minutes after each flush.

12.1.1.1 A pre-measured timing chain should be installed in the engine as listed in section **7.11 Chain and Camshaft Installation Procedure**. The timing chain should have been coated in EF-411 oil before break-in installation as listed in section **7.9.5 Chain and Camshaft Installation Procedure**.

12.1.1.2 Charge the engine with 3600 grams of test oil. Prime and install a new oil filter. The engine is now ready to start Step 1 of the break in as listed in **Table 2**.

**TABLE 2 Sequence CW Break-in Schedule**

Step	Speed (RPM)	Load (N-m)	Time per stage (Hr:Min)	Total Time (Hr:Min)
<b>Charge engine with 3600 grams of new test oil and new oil filter</b>				
1	Idle	0	0:30	0:30
<b><u>Oil Flush 1</u> -Shut engine down and drain used test oil and remove oil filter. Add 3600 grams of new test oil and install new oil filter</b>				
<b>Start engine and let idle for 5 minutes</b>				
2	1500	38	0:30	1:00
3	2000	72	0:30	1:30
4	2500	111	0:30	2:00
5	3000	135	0:30	2:30
6	3000	150	3:15	5:45
7	2000	72	0:15	6:00
8	3250	155	0:15	6:15
9	3500	155	0:15	6:30
10	3750	155	0:15	6:45
11	4000	155	1:15	8:00



<b>Bring engine to idle for 5 minutes and shut down.</b>				
<b>Oil Flush 2- Shut engine down and drain used test oil and remove oil filter. Add 3600 grams of new test oil and install new oil filter.</b>				
12	Idle	0	0:15	8:15
<b>Oil Flush 3- Shut engine down and drain used test oil and remove oil filter.</b>				

12.1.1.3 The controlled parameters during break in are listed in [Table 3](#). All other controls are left wide open/free flowing. The engine does not produce enough heat in the early steps to reach all target temperatures. All controlled parameters are expected to be on target at the beginning of Step 4.

**TABLE 3 Sequence CW Break-in Controlled Parameters**

<b>Break In Controlled Parameters</b>	
Coolant Out Temp.	85 degC
Oil Gallery Temp.	100 degC
Inlet Air Pressure	0.05kPa
Air Charge Temp.	37 deg C
Inlet Air Temp.	30 degC

12.1.1.4 The laboratory ambient atmosphere shall be reasonably free of contaminants. The temperature and humidity levels of the operating area are not specified. A fan is allowed to divert air toward the turbocharger during break in only.

12.1.1.5 The break-in allows an opportunity to check PCM system operation, check for leaks in the various systems and purge air from the cooling systems. Specifications concerning the break-in procedure are shown in [Table 2](#) and [Table 3](#). The engine start-up and shutdown procedures are detailed in [12.2.1](#) and [12.2.4](#) respectively.

12.1.1.6 The same test PCM calibration U5J0110D1VEPfn13\_78\_2 is used during break in. Step 2 is a good time to check if the Lambda enrichment in the PCM calibration is working properly.

12.1.1.7 Oil Flush 1 is performed at the end of Step 1. Drain the used oil and remove the used oil filter. Let the oil drain for 15 minutes. Charge the engine with 3600 grams of new test oil. Prime a new oil filter with test oil and install. The engine is now ready to start Step 2 of the break in. Continue to run the break in until the end of Step 11 with the same oil charge.

12.1.1.8 Oil Flush 2 is performed at the end of Step 11 after the engine has idled for 5 minutes and shuts down. Drain the used test oil and remove the used oil filter. Let the oil drain for 15 minutes. Charge the engine with 3600 grams of new test oil. Prime a new oil filter with test oil and install. The engine is now ready to start Step 12 of the break in.

12.1.1.9 Oil Flush 3 is performed at the end of Step 12. Drain the used test oil and remove the used oil filter. Let the oil drain for 15 minutes.

12.1.1.10 Remove the timing chain for cleaning and 0 hour measurement according to the [Timing Chain Cleaning Procedure](#) listed in section [7.10](#) and [Timing Chain Measurement Procedure](#) listed in section [7.11](#). After measuring the chain, coat the chain in new test oil and install it back into the engine using the procedure described in the [Timing Chain and Camshaft Installation Procedure](#) listed in section [7.9.5](#).

12.1.1.10 After the timing chain has been installed, measure 3600 grams of test oil. With a portion of this 3600 grams of new test oil, prime a new oil filter and install it on the engine. Charge the engine with the remaining new test oil for the final oil charge.

12.1.1.11 Start and run the engine at idle for 5 minutes, then shut down the engine. Record the dipstick level in millimeters 20 ± 2 minutes after the engine is shutdown. Rotate the calibrated dipstick 360 degrees while still in the oil pan to capture the highest point. Remove the dipstick to view the reading. Break-in and the initial oil level measurement is now completed and test is ready to begin. No makeup is added to the test

12.2 *Engine Operating Procedure:*

12.2.1 *Engine Start-up*—Use the following detailed procedure each time the engine is started.

12.2.1.1 Turn on the ignition, safety circuits, fuel management system, fuel pump, and the blowby coolant pump.

12.2.1.2 Insure the intake-air supply duct is connected.

12.2.1.3 *Crank The Engine*—The engine should start within 4 seconds. Since the engine has a crankshaft driven oil pump, cranking oil pressure might be low. If used, disable a low oil pressure ignition shutoff during engine starting to allow the engine to start even though the oil pressure is low. The inclusion of this type switch could lead to excessive cranking time to start the engine.

12.2.1.4 If starting difficulties are encountered, the laboratory should not continue to crank the engine excessively. Perform diagnostics to determine the reason the engine will not start (ignition problems, insufficient or excess fuel, and so forth). (**Warning**— Excessive cranking times can promote additional fuel dilution of the test oil and can adversely affect the test. In addition to other precautions, do not attempt to pour gasoline into the intake-air horn.)

12.2.2 *Test Start* —Conduct the test according to the operational parameters shown in [Table 4](#). The test stage and ramp order is shown in [Table 5](#).

**TABLE 4 Test Operational Parameters**

Parameter	Units	Stage 1	Stage 2
Duration	Min	120	60
Engine Speed	RPM	1550 $\pm$ 5	2500 $\pm$ 5
Torque	NtM	50 $\pm$ 2	128 $\pm$ 2
Oil Gallery Temperature	degC	50 $\pm$ 0.5	100 $\pm$ 0.5
Coolant Out Temperature	degC	45 $\pm$ 0.5	85 $\pm$ 0.5
Coolant Flow	L/min	40 $\pm$ 2	70 $\pm$ 2
Inlet Air Pressure	kPa	0.05 $\pm$ 0.02	
Coolant Pressure	kPa	70 $\pm$ 2	
Inlet Air Temperature	degC	32 $\pm$ 0.5	
Exhaust Back Pressure	kPa	104 $\pm$ 2	107 $\pm$ 2
Air Charge Temperature	degC	30 $\pm$ 0.5	
AFR	Lambda	0.78 $\pm$ 0.05	1 $\pm$ 0.05
Blowby outlet Temperature	degC	23 $\pm$ 2	78 $\pm$ 2
Humidity	g/kg	11.4 $\pm$ 1.0	

12.2.2.1 Start the engine and let idle for 5 minutes then shut the engine down, these 5 minutes do not count toward test time. Take a dip 20 $\pm$ 2 minutes after the engine shutdown. Follow the direction in section 12.3.4.2 on how to take the dip reading. Record the 0hr dip reading.

12.2.2.2 Start the engine and let idle for 5 minutes, these 5 minutes do not count toward total test time. Start the 30 minute ramp to stage 1 conditions. The test timer starts at the beginning of this ramp to stage 1. Use the ramping conditions shown in [Table 5](#).

12.2.3 *Cyclic Schedule, General Description:*

12.2.3.1 The test is composed of two stages as shown in [Table 4 and 5](#). Together, the two stages and two ramps comprise one cycle. Each cycle lasts 4 hours and is repeated 54 times for a total of 216 hours. Six consecutive cycles are completed each 24 hour period. Oil level measurement and sampling is performed every 24hrs. The oil level measurement and sampling procedure does not count toward test time and is described in section [12.3.4](#).

12.2.3.2 *Test Cycle:* Each cycle is 4 hours long and contains a Stage 2-1 ramp for 30 minutes (or start up/idle to stage 1 at test start or after an oil dip) , a Stage 1 for 120 minutes, a Stage 1-2 ramp for 30 minutes, a Stage 2 for 60 minutes. This is the only time that is counted as test time.

12.2.3.3 *Ramps:* The ramps between stages are 30 second engine speed and coolant flow ramps, 30 minute oil and coolant temperature ramps and 60 minute blowby temperature ramps, to stabilize at stage conditions. The load ramps different lengths. Ramp details are shown in [Table 5](#). The ramps are considered complete after 30 minutes

when the oil and coolant temperatures have reach stage conditions at this time the stage timer starts. Note that half of the blowby temperature ramp occurs during stage operation. The coolant and oil temperature ramps are linear ramps between the steady state stage conditions, within  $\pm 2$  minutes, for the first 25 minutes to reach the next stage conditions. After the next stage oil and coolant temperatures are achieved between 23 and 27 minutes, use the last remaining minutes of the 30 minute ramp to stabilize at the stage conditions shown in Table 4. Figure A2.23 shows the desired shape of the ramps. The rate of speed, temperature, fuelling and load changes, as well as the amount of enrichment between stages, can influence test severity and engine component wear. Therefore, ramping rates are very important.

**TABLE 5 Stages Order and Ramp Description**

<b>Stage</b>	<b>Description</b>	<b>Time (min)</b>
Stage 1	Stage 1 conditions	120
Ramp 1 – 2 (or start up/idle to stage 2)	Linear 30 sec speed and flow ramps. 3-3.5 minute load ramp. Linear 30 minute oil and coolant temperature ramp. 60 minute blowby temperature ramp, to Stage 2 (Ramp 1-2 details below)	30
Stage 2	Stage 2 conditions	60
Ramp 2 – 1 (or start up/idle to stage 1)	Linear 30 sec speed and flow ramps. 3.5-4.5 minute load ramp. Linear 30min oil and coolant temperature ramp. 60 minute blowby temperature ramp, to Stage 1 (Ramp details below)	30
Stage ramp	Ramp details	
Stage 1-2 load ramp	30 sec      95-100 Nm 90 sec      115-120 Nm 180-240 sec    126-130 Nm	
Stage 2-1 load ramp	30 sec      75-85 Nm 90 sec      55-60 Nm 150-180 sec    48-52 Nm	
Stage 1-2 oil temperature ramp	Linear ramp reach 75 degC by 12.5 $\pm$ 2 minutes reach 100 $\pm$ 0.5 degC by 25 $\pm$ 2 minutes remaining time to stabilize at 100 $\pm$ 0.5	30
Stage 2-1 oil temperature ramp	Linear ramp reach 75 degC by 12.5 $\pm$ 2 minutes reach 50 $\pm$ 0.5 degC by 25 $\pm$ 2 minutes remaining time to stabilize at 50 $\pm$ 0.5	30
Stage 1-2 coolant temperature ramp	Linear ramp reach 65 degC by 12.5 $\pm$ 2 minutes reach 85 $\pm$ 0.5 degC by 25 $\pm$ 2 minutes remaining time to stabilize at 85 $\pm$ 0.5	30

Stage 2-1 coolant temperature ramp	Linear ramp reach 65 degC by 12.5± 2 minutes reach 45±0.5 degC by 25±2 minutes remaining time to stabilize at 45±0.5	30
Stage 1-2 blowby temperature ramp	Linear ramp from 23 deg C to 73 deg C reach 49 degC by 15± 2 minutes reach 73 degC by 30±2 minutes Linear ramp from 73 deg C to 78 deg C reach 78±2 degC by 60 minutes (30 minutes of the this ramp is run during Stage 2)	60
Stage 2-1 blowby temperature ramp	Linear ramp from 78 deg C to 32 deg C reach 55 degC by 15± 2 minutes reach 32 degC by 30± 2 minutes Linear ramp from 32 deg C to 23 deg C reach 23±2 degC by 60 minutes (30 minutes of the this ramp is run during Stage 1)	60

#### 12.2.4 Engine Shutdown:

12.2.4.1 *Scheduled Shutdown Procedure*—Follow the procedure detailed as follows, each time a scheduled shutdown is performed. Scheduled shutdowns include shutdowns that occur during engine break-in and oil leveling:

- (1) Bring the engine speed to idle. Temperatures and flows are set to go free flowing to cool the engine.
- (2) Switch the ignition off. Turn off power to the ignition power. Turn off fuel and coolant pumps.
- (3) Reduce the intake-air pressure to atmospheric.

12.2.4.2 *Unscheduled Engine Shutdown*—Follow the procedure detailed as follows, each time an unscheduled engine shutdown is performed:

- (1) Stop test timer when ramp down starts.
- (2) 30 second ramp to idle and all temperatures and flows are set free flowing to cool the engine down.
- (3) Let the engine idle for a total of 2 minutes, the 30 second ramp down counts as part of the 2 minutes. Shut the engine down after 2 minutes.
- (3) Switch the ignition off.
- (4) Turn off fuel and coolant pumps.
- (5) Reduce the intake-air pressure to atmospheric.

12.2.4.3 *Start-Up After Oil Leveling Period*—Follow the procedure detailed as follows, each time an engine start-up is performed after an oil leveling period.

(1) *Start*—5 min in idle; then ramp to stage 1 conditions for 30 minutes as shown in Table 5. The 5 minute of idle does not count toward the total test timer. The test timer starts at the beginning of the ramp to stage 1 conditions.

12.2.5 *Unscheduled Downtime*—The oil leveling periods of 25±2 min are the only scheduled shutdowns allowed during the test. However, the test can be interrupted to perform necessary maintenance. Note all unscheduled downtime on the **Supplemental Operational Data Form** of the final test report.

12.2.6 *Resumption of Test Time After Unscheduled Shutdown*—After an unscheduled shutdown, test time does not begin until the engine has reached operating conditions for the stage at which the shutdown occurred. On start-up idle for 5 minutes then use the ramp as shown in Table 5 for reaching the appropriate stage.

12.2.6.1 *Start-Up After Unscheduled Shutdown*—Follow the procedure detailed as follows, each time an engine start-up is performed after an unscheduled shutdown.

*Return to Stage 1*—Engine idles for 5 minutes then ramp to stage 1 conditions for 30 minutes using the ramp as shown in Table 5. The total test timer and stage timer resumes from where it left off before being shut down once Stage 1 conditions are reached.

*Return to Stage 2*— Engine idles for 5 minutes then ramp to stage 2 conditions for 30 minutes using the ramp as shown in Table 5. The total test timer and stage timer resumes from where it left off before being shut down once Stage 2 conditions are reached.

#### 12.3 Periodic Measurements and Functions:

12.3.1 *Blowby Flow Rate Measurement*— Every sixth cycle, measure and record the blowby flow rate at 30 min to 45 min into Stage 2. The engine shall be stable and operating at normal Stage 2 operating conditions. Measure blowby when the gas temperature is at least 32 °C. The installation of the blowby flow rate measurement apparatus

is shown in Fig. 9 The procedure for measuring blowby flow rate is detailed in 12.3.1.1. Complete only one set (Stage 2) of blowby flow rate measurement during each six cycles. Under special circumstances additional blowby flow rate measurements can be performed to determine or verify a problem with the flow rate measurement apparatus or the engine. Record additional blowby flow rate measurements and an explanation of the reason for the additional measurements. Include these data in the supplemental operational data in the final test report.

12.3.1.1 Connect the blowby measurement device to the pressurized air source.

12.3.1.2 Open the flow valve (bleeder valve) completely.

12.3.1.3 Connect the blowby apparatus flow line to the 3-way valve located between the oil separator and intake tube.

12.3.1.4 Position the 2-way valve to divert air to the monometer from the hollow PCV valve.

12.3.1.5 Position the 2-way in between the PCV and throttle body to keep air from entering the throttle body.

12.3.1.6 Position the 3-way valve to divert intake manifold vacuum from the engine PVC to the exhaust plumbing of the blowby apparatus meter.

12.3.1.4 Adjust the flow valve (bleeder valve) to maintain crankcase pressure at (0 to 0.025) kPa.

12.3.1.5 Record the differential pressure across the blowby meter orifice, record the blowby gas temperature, and the barometric pressure.

12.3.1.6 After completing the measurement, return the engine to normal operating configuration. First, reposition the 3-way valve and both 2-way valves to ensure porting of the intake vacuum to the engine PCV; second, disconnect blowby apparatus hose from the closed port of the 3-way valve.

11.3.1.7 Calculate the blowby flow rate and correct the value to standard conditions (38 °C, 100.3 kPa) using the calibration data for that orifice.

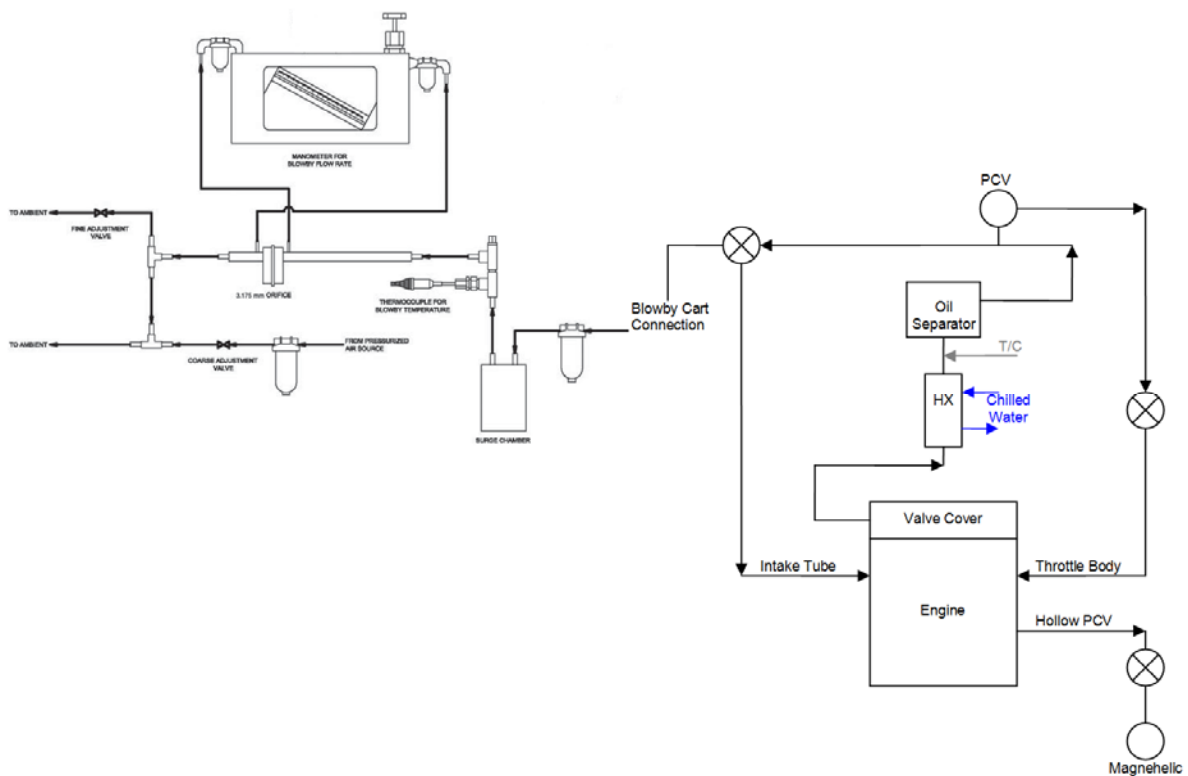

**Figure 9 Blowby Cart Connection**

12.3.2 Parameter Logging

12.3.2.1 Refer to Table 6 for required parameter to record and Table 7 for information on setting up the CANBUS for logging PCM parameters and typical ranges for these parameters.

TABLE 6 Parameter Logging

<b>Controlled</b>	<b>Engine Speed</b>	<b>rpm</b>
	<b>Engine Load</b>	<b>Nm</b>
	<b>Coolant Out Temp</b>	<b>deg C</b>
	<b>Oil Gallery Temp</b>	<b>deg C</b>
	<b>Air Charge Temp</b>	<b>deg C</b>
	<b>Inlet Air Temp</b>	<b>deg C</b>
	<b>Inlet Air Press</b>	<b>kPaG</b>
	<b>Exhaust Back Press</b>	<b>kPaA</b>
	<b>Humidity</b>	<b>g/kg</b>
	<b>Coolant Pressure</b>	<b>kPaG</b>
	<b>Coolant Flow</b>	<b>L/m</b>
	<b>Blowby Outlet Temp</b>	<b>deg C</b>
	<b>Lambda</b>	<b>unitless</b>

<b>Monitored</b>	<b>Barometric Pressure</b>	<b>kPaA</b>
	<b>Oil Gallery Pressure</b>	<b>kPaG</b>
	<b>Oil Head Pressure</b>	<b>kPaG</b>
	<b>Oil Out Temp</b>	<b>deg C</b>
	<b>Exhaust temp</b>	<b>deg C</b>
	<b>Crank Case Pressure</b>	<b>kPaG</b>
	<b>Fuel Pressure</b>	<b>kPaG</b>
	<b>Power</b>	<b>kW</b>
	<b>Pre-Intercooler Air Pressure</b>	<b>kPaA</b>
	<b>Ambient Temperature</b>	<b>degC</b>
	<b>Coolant In Temperature</b>	<b>degC</b>
	<b>Blowby heat exchanger coolant</b>	<b>L/m</b>
	<b>Boost Pressure</b>	<b>kPaA</b>
	<b>Fuel Temp</b>	<b>deg C</b>
	<b>Fuel Flow</b>	<b>kg/hr</b>
	<b>Inlet Air Temperature</b>	<b>Deg C</b>
	<b>Manifold Absolute Pressure (MAP)</b>	<b>kPaA</b>
	<b>Blowby heat exchanger coolant in</b>	<b>degC</b>

<b>PCM CAN BUS Channels</b>	<b>Ignition Timing Advance for #1 Cylinder</b>	<b>Deg</b>
	<b>Absolute Throttle Position</b>	<b>%</b>
	<b>Engine Coolant Temperature</b>	<b>Deg C</b>
	<b>Intake Air Temperature</b>	<b>Deg C</b>
	<b>Equivalence Ratio (Lambda)</b>	<b>unitless</b>
	<b>Absolute Load Value</b>	<b>%</b>
	<b>Intake Manifold Absolute Pressure</b>	<b>kPa</b>
	<b>Fuel Rail Pressure</b>	<b>kPa</b>
	<b>Accelerator Pedal Position</b>	<b>%</b>
	<b>Boost Absolute Pressure - Raw Value</b>	<b>kPa</b>
	<b>Turbocharger Wastegate Duty Cycle</b>	<b>%</b>
	<b>Actual Intake (A) Camshaft Position</b>	<b>Deg</b>
	<b>Actual Exhaust (B) Camshaft Position</b>	<b>Deg</b>
	<b>Intake (A) Camshaft Position Actuator Duty Cycle</b>	<b>%</b>
	<b>Exhaust (B) Camshaft Position Actuator Duty Cycle</b>	<b>%</b>
<b>Charge Air Cooler Temperature</b>	<b>Deg C</b>	

**Table 7 PCM Parameter Logging information**

Mode	PID Number(Hex)	Parameter Description	Type	Bytes	Scale	Offset	Minimum	Maximum	Units
1	0E	Ignition Timing Advance for #1 Cylinder	Unsigned Numeric	1	0.5	-64	-64	63.5	Deg
1	11	Absolute Throttle Position	Unsigned Numeric	1	0.392156863	0	0	100	%
1	5	Engine Coolant Temperature	Unsigned Numeric	1	1	-40	-40	215	Deg C
1	0F	Intake Air Temperature	Unsigned Numeric	1	1	-40	-40	215	Deg C
1	34	Equivalence Ratio (Lambda)	Unsigned Numeric	2	3.0518E-05	0	0	2	unitless
1	43	Absolute Load Value	Unsigned Numeric	2	0.392156863	0	0	25700	%
1	0B	Intake Manifold Absolute Pressure	Unsigned Numeric	1	1	0	0	255	kPa
1	23	Fuel Rail Pressure	Unsigned Numeric	2	10	0	0	655350	kPa
1	49	Accelerator Pedal Position	Unsigned Numeric	1	0.392156863	0	0	100	%
22	033E	Boost Absolute Pressure - Raw Value	Unsigned Numeric	2	0.007629395	0	0	499.9924	kPa
22	462	Turbocharger Wastegate Duty Cycle	Unsigned Numeric	2	0.003051758	0	0	199.9969	%
22	318	Actual Intake (A) Camshaft Position	Signed Numeric	2	0.0625	0	-2048	2047.938	Deg
22	319	Actual Exhaust (B) Camshaft Position	Signed Numeric	2	0.0625	0	-2048	2047.938	Deg
22	316	Intake (A) Camshaft Position Actuator Duty Cycle	Unsigned Numeric	2	0.003051758	0	0	199.9969	%
22	317	Exhaust (B) Camshaft Position Actuator Duty Cycle	Unsigned Numeric	2	0.003051758	0	0	199.9969	%
22	461	Charge Air Cooler Temperature	Signed Numeric	2	0.015625	0	-512	511.9844	Deg C

12.3.2.2 The data collected for the parameters shown in Table 6 should be used to determine that the engine is operating correctly and should be checked continuously throughout the test. Fuel flow and exhaust temperature in particular should be continuously monitored to detect cylinder misfires and should remain in the ranges shown in

Table 8 for the entire test for steady state portions of the test.

**Table 8 Typical Uncontrolled Parameter Ranges**

Parameter	Stage 1	Stage 2
Fuel Flow, Kg/Hr	3.2 – 3.5	8.0 – 8.5
Exhaust Temperature, deg C	400 - 430	640-680

12.3.4 *Oil Sampling:*

12.3.4.1 *Oil level Measurement and Sampling Procedure*— Oil level measurement and sampling occur at intervals of 24 hours or 6 cycles. The procedure and sample times are listed in **Table 9**. Every 6<sup>th</sup> cycle after Stage 2 has completed the total test timer stops. Perform a 30 seconds speed and load ramp to idle and have the engine idle for 4.5 minutes. Take the oil sample during these 4.5 minutes of idle. Oil sample is taken from the T connection on the oil filter housing leading to a valve. The location of the T where the oil is drawn is shown in **Figure A2.15**.

12.3.4.2 The minimum oil level allowed for this test is 100mm reading on the calibrated oil dipstick. Rotate the calibrated dipstick 360 degrees while still in the oil pan to capture the highest point. Remove the dipstick to view the reading.

**TABLE 9 Oil Level Measurements and Sampling**

Test Hrs	24	48	72	96	120	144	168	192	216
Test Cycles	6	12	18	24	30	36	42	48	54
<b>1</b>	Remove a 120-150 mL purge sample while the engine is at idle.								
<b>2</b>	Remove a 60 mL analysis sample while the engine is at idle.								
<b>3</b>	Shut-down the engine 5 min after the start of oil sampling and leveling stage.								
<b>4</b>	Immediately return the purge sample to the engine.								
<b>5</b>	Record the dipstick level in millimeters 20 ± 2 minutes after the engine is shutdown.								
<b>6</b>	Log the oil level. The difference between the oil level and the Test Full mark is oil consumed or gained. Use the chart in <b>Table 12</b> to determine the level.								
<b>7</b>	Restart the engine after shutdown.								

12.3.5 *General Maintenance*—The scheduled shutdown periods of 30 min during oil leveling allow limited opportunity for engine and stand maintenance. In addition, the test can be shut down at any convenient time to perform unscheduled maintenance. However, minimize the duration of a shutdown. Report any unscheduled shutdown on the Supplemental Operational Data Sheet.

12.4 *Special Maintenance Procedures*—Functions that require special maintenance procedures are listed in this section. These maintenance procedures are specifically detailed because of the effect on test validity or because they require special care while being completed. Check the oil level before performing any maintenance requiring removing the front cover or rear seal housing. If the level is above 130 mm, the oil level is above the oil pan rail and a portion of the oil must be removed from the oil drain plug before performing the maintenance to insure oil doesn't leak over the pan rail. Use a clean container to catch the oil removed from the pan. Return the oil to the engine after the maintenance is completed before restarting the test.

12.4.1 *Blowby Flow Rate Adjustment*—A blowby adjustment can only be within the first 24 hours of the test. A blowby measurement is taken on the first test Stage 2 after break in (3.25-3.45hrs) gives a good hint on how the



blowby will perform for the rest of the test. Blowby might drop from the post break-in level but the corrected average Stage 2 blowby for the test during the first 120 hours of the test must fall within the range from 65 L/min to 75 L/min as listed in **Table 10**. The first 24 hour blowby measurement must also be above 70 L/min. The Stage 2 times are also listed in **Table 10**. Adjust the blowby by changing the ring gaps or replacing piston rings as necessary. Suggested ring gaps are shown in **Table 11** that should produce the above blowby levels. These can be adjusted as necessary to achieve the correct blowby level. . Use the ring cutting procedure outlined in **7.8.5.2**.

**TABLE 10 2<sup>nd</sup> Stage Blowby Readings**

Stage 2 Blowby Readings		
Test Hours	Blowby Reading	Use these boxes for AVG.
3.5-3.75		
23.5-23.75		Must be above 70LPM
47.5-47.75		
71.5-71.75		
95.5-95.75		
119.5-119.75		
143.5-143.75		Blowby average between 65-75LPM.
167.5-167.75		
191.5-191.75		
215.5-215.75		

**TABLE 11 Suggested Piston Ring Measurements**

Top piston ring gap	0.065 inches
2nd piston ring gap	0.070 inches

12.4.1.1 *High Blowby Flow Rate Adjustment*—Reduce high blowby flow rate by replacing the compression rings with new rings that have smaller ring gaps.

12.4.1.2 *Low Blowby Flow Rate Adjustment*—Increase low blowby flow rate by increasing the ring gaps of the compression rings.

12.4.2 *Engine Disassembly and Reassembly for Maintenance (Before End of Test):*

12.4.2.1 Engine assembly and disassembly shall adhere to the procedures in **7.8** and **12.6.2**, respectively

12.4.2.2 When the engine is disassembled for maintenance, drain as much test oil as possible from the oil pan into a clean container, and retain the oil for installation in the engine after reassembly. Take precautions to ensure the oil is not contaminated and to ensure the deposits are not disturbed on any parts. All parts should be placed in or over clean drain pans to collect oil that drains off while maintenance is being performed. The timing chain should be place in a container to prevent it from getting contaminated.

12.4.2.3 During reassembly, used drained test oil may be used to lubricate the engine parts. Do not use EF-411 oil or new test oil during engine reassembly. After the engine has been reassembled, charge the oil pan with the used test oil removed from the oil pan and collected from the engine parts during disassembly and maintenance. Do not add any new test oil to the pan.

12.5 *Diagnostic Data Review*—This section outlines significant characteristics of specific engine operating

parameters. The parameters can directly influence the test or can be used to indicate normalcy of other parameters.

#### 12.5.1 PCM parameters

12.5.2 *Engine Torque*—Engine torque is controlled in Stage 1 and 2 . It should remain relatively constant throughout a test and from test to test. Large differences in torque reading could be indicative of control or engine problems.

12.5.3 *Fuel Consumption Rate*—The fuel consumption rate should remain relatively constant throughout the test. Fuel consumption rate is not a specifically controlled parameter but is used as a diagnostics tool.

#### 12.5.4 *Exhaust Gas Component Levels:*

12.5.4.1 Use the Lambda levels in the exhaust gas to determine the characteristics of combustion that occur during the test. Use this parameter to determine the normalcy of combustion and any significant changes in combustion that occur throughout a particular test. Lambda in all two stages is controlled by the program in the Powertrain Control Module. No adjustments can be made to change the exhaust gas Lambda. If Lambda differs from what appears in [Table 4](#), check the PCM and test cell control system. Correcting a fault in the PCM and test cell control system is the only way to achieve the correct Lambda value.

12.5.5 *Crankcase Pressure*—Crankcase pressure is a function of blowby flow rate and PCV valve flow. High crankcase pressure is usually caused by high blowby flow rate or a significant loss of PCV valve flow. Incorrect three-way valve plumbing or port plugging also promotes high crankcase pressure. Low or negative crankcase pressure might be caused by low blowby flow rate or a restriction of vent air to the PCV valve.

12.5.6 *Oil Pressure*—The oil pressure is a function of oil viscosity and operating temperature. The oil pressure should remain consistent throughout the test, unless the oil exhibits a significant change in viscosity.

12.5.7 *Oil Temperature Differential*—The oil temperature differential is primarily a function of oil flow rate and oil viscosity and is normally stable throughout the test. The differential can change if the oil viscosity changes significantly during the test.

12.5.8 *Coolant Temperature Differential*—The coolant temperature differential is primarily a function of the coolant flow rate and is normally stable throughout the test. Large variations in the differential can be caused by coolant flow rate or temperature measurement errors.

#### 12.6 *End of Test Procedure:*

12.6.1 *Final Drain*—Drain the engine coolant after the completion of the last test cycle. Engine oil can be drained with the engine in or out of the engine stand.

12.6.2 *Engine Disassembly*—During disassembly, ensure the original location of the parts can be identified with respect to either the cylinder number, valve location, bearings, etc.

12.6.3 *Parts Layout for Measurement*- Lightly wipe down the timing chain of any excess oil and make sure to keep the chain free of any contaminants or debris. Prepare the timing chain for end of test measurement as listed in the *Timing Chain Measurement and Cleaning Procedure*.

**Table 12 :Typical Dipstick Oil Level to Charge Conversions**

Dip Stick Level (mm)	Oil Charge (gm)		Dip Stick Level (mm)	Oil Charge (gm)		Dip Stick Level (mm)	Oil Charge (gm)
160	4915		99	2577		38	1100
159	4866		98	2529		37	1084
158	4769		97	2505		36	1068
157	4720		96	2480		35	1060
156	4623		95	2431		34	1052
155	4574		94	2407		33	1044
154	4525		93	2383		32	1035
153	4501		92	2371		31	1027
152	4477		91	2359		30	1019
151	4379		90	2346		29	1011
150	4355		89	2334		28	1003
149	4331		88	2310		27	995
148	4233		87	2285		26	986
147	4185		86	2236		25	978
146	4136		85	2212		24	970
145	4087		84	2188		23	966
144	4038		83	2164		22	963
143	4014		82	2139		21	959
142	3990		81	2115		20	955
141	3965		80	2090		19	951
140	3940		79	2058		18	948
139	3916		78	2025		17	944
138	3892		77	1993		16	940
137	3844		76	1944		15	936
136	3795		75	1920		14	933
135	3746		74	1896		13	929
134	3697		73	1872		12	925
133	3673		72	1847		11	922
132	3649		71	1798			
131	3624		70	1774			
<b>130</b>	<b>3600</b>	<b>Full Mark</b>	69	1749			
129	3502		68	1733			
128	3454		67	1717			
127	3430		66	1701			
126	3405		65	1652			
125	3357		64	1628			
124	3308		63	1603			
123	3259		62	1587			
122	3235		61	1571			
121	3210		60	1555			
120	3162		59	1531			
119	3138		58	1506			
118	3113		57	1482			
117	3064		56	1457			
116	3016		55	1433			
115	2967		54	1409			
114	2943		53	1360			
113	2918		52	1344			
112	2870		51	1327			
111	2846		50	1311			
110	2821		49	1287			
109	2797		48	1262			
108	2772		47	1246			
107	2756		46	1230			
106	2739		45	1214			
105	2723		44	1198			
104	2699		43	1181			
103	2675		42	1165			
102	2659		41	1149			
101	2642		40	1132			
100	2626	Min	39	1116			