

Sequence VIE/F GM Kit Assembly Manual

NOTE: Follow cleaning procedure for short block and heads prior to final assembly. A Parts List is Attachment A.

The cleaning procedure applies to the following components of the KIT:

Quantity	Part Number	Description
1	12641093	HEAD ASM-CYL (W/ VLV)(LH,LY7)
1	12635560	HEAD ASM-CYL (W/ VLV)(RH, LY7)
1	19206165	BLOCK, SHORT HFV6

The parts listed above will be received with a CPC applied by the OEM to prevent corrosion of the parts. The CPC shall be removed from the parts prior to assembly of the engine. Once the parts have been cleaned it is recommended to assemble the engine and store in humidity and temperature controlled environment until is needed for installation on a stand. The engine shall not be assembled if rust is present.

Procedure:

Cleaning procedure for the Head assemblies (PNs: 12641093, 12635560):

1. Remove parts from package.
2. Spray parts with degreasing solvent, soak for 15-30 minutes and repeat spray with degreasing solvent. Repeat this process as necessary until CPC is removed from the parts. Two iterations of the process have been found to be sufficient.
3. Spray parts with 50/50 degreasing solvent and EF411 followed by air dry using clean dry compressed shop air to remove excess 50/50.

Cleaning procedure for the short block (PN: 19206165):

1. Remove parts from package
2. Position the block such that the cylinder bores are facing downwards. Positioning the short block will reduce the potential for dissolved CPC penetrating the short block.

Oil Pan Installation

Tools required:

EN 46109 Guide Pin Set

OHT Oil Pan P/N

- 1) Install the 8 mm guide pins from the EN46109 guide pin set into the center of the oil pan rail bolt hole on each side of the engine block.
- 2) Install crankshaft and set to TDC at the bottom.
- 3) Wipe both with a lint free cloth.

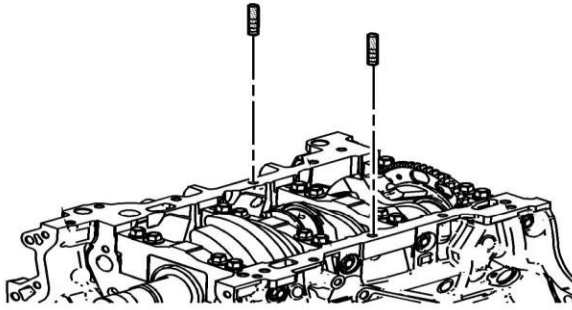

- 4) Place a 3 mm bead of RTV sealant, GM P/N 12378521, on the block pan rail and the crankshaft rear oil seal housing (1)

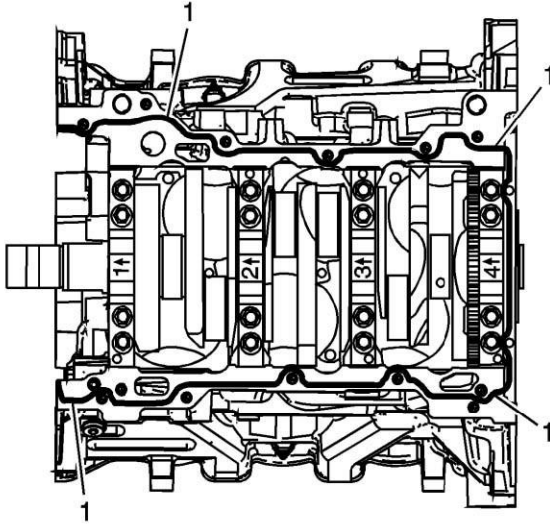

- 5) Position the oil pan (P/N) onto the block.
- 6) Loosely install the oil pan bolts.
- 7) Tighten the 8 mm bolts (1-11) to 23 N·m.
- 8) Tighten the 6 mm bolts (12, 13) to 10 N·m.

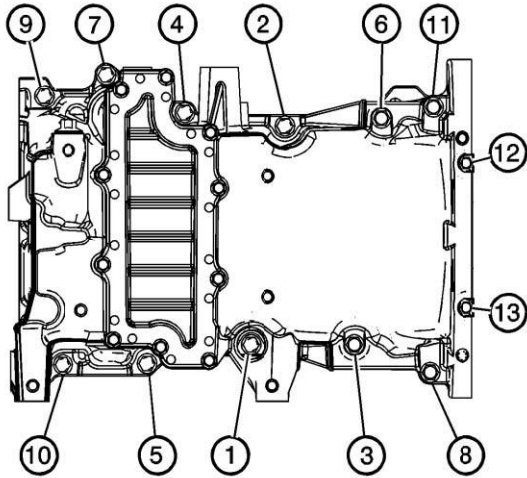

Note: View may not be representative of the VIE/F Oil Pan. Also any time the oil pan is removed and or installed, ensure the oil pickup tube “O-ring” is properly installed.

Cylinder Head Installation/Camshaft Positioning

Important: This engine is NOT free a free spin engine. The camshafts must be properly positioned in the cylinder heads prior to installation. Using a large open end wrench on the hex cast into the camshaft behind the number one journal, position the camshafts so the flat on the back of each camshaft is parallel to the gasket seating surface for the cylinder head rocker cover.

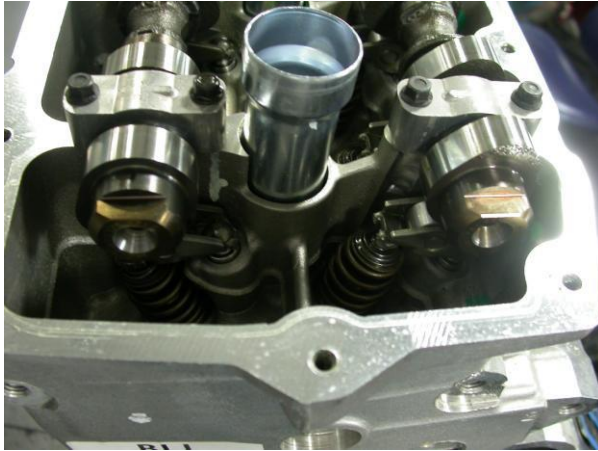

Insure all four camshafts are positioned with flats parallel to rocker cover sealing surface.

WARNING: DO NOT USE THE CAM GEAR TO POSITION CAMS AS THE VALVE SPRING PRESSURE MAY CAUSE THE CAM TO ROTATE AFTER POSITIONING AND THE LEADING EDGES OF THE CAM GEARS ARE VERY SHARP.

AS AN ADDED MEASURE OF PROTECTION, ROTATE THE CRANKSHAFT SO THERE ARE NO PISTONS AT TDC DURING CYLINDER HEAD INSTALLATION.

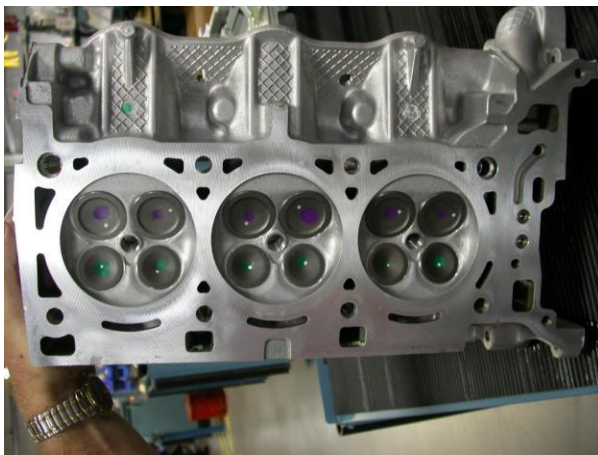

By position the flats parallel, you assure the cam lobes are all on a portion of the base circle and the engine will thereby be a free spin so you can rotate the crankshaft without the pistons hitting the valves.

Cylinder Head Installation-Right Side

- 1) Clean the mating surfaces of the engine block, cylinder head and fastener bosses.
Important: DO NOT allow oil on the cylinder head bolt bosses.
- 2) Insert dowel pin PN 12570326 in left and right side of block to align gaskets.
- 3) Install an NEW right cylinder head gasket using the deck face locating pins for retention.

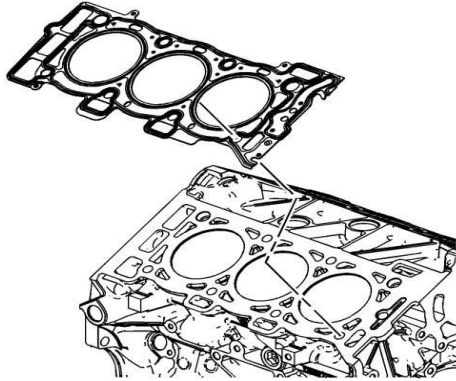

- 4) Place the right cylinder head in position on the deck face.

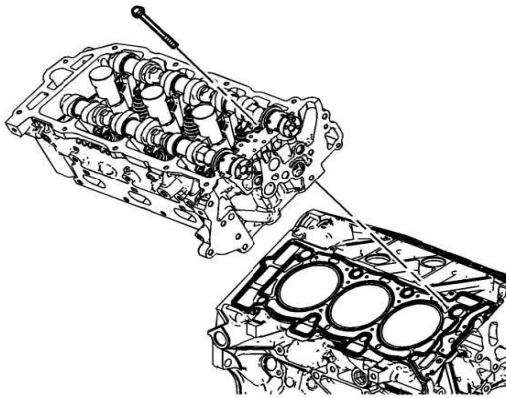

- 5) Install new M11 cylinder head bolts. Tighten the first pass in sequence to 45 N·m. Tighten the second pass in sequence an additional 120°.

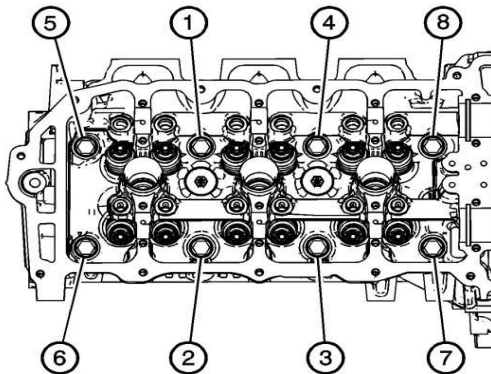

Cylinder Head Installation Left Side

1) Clean the mating surfaces of the engine block deck, cylinder head and fastener bosses and inspect for imperfections.

Important: DO NOT allow oil on the cylinder head bolt bosses. Ensure all solvent from initial cleaning has been removed.

2) Install a NEW left cylinder head gasket using the deck face locating pins for retention.

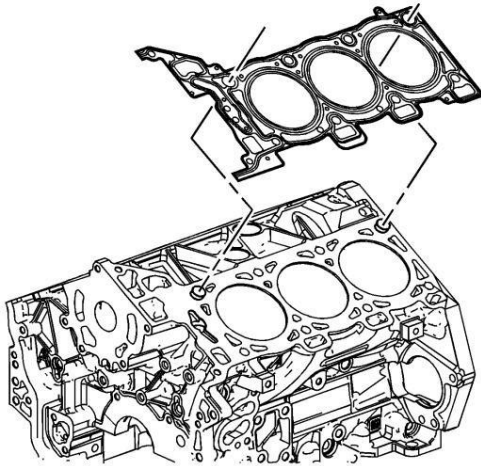

3) Place the left cylinder head in position on the deck face.

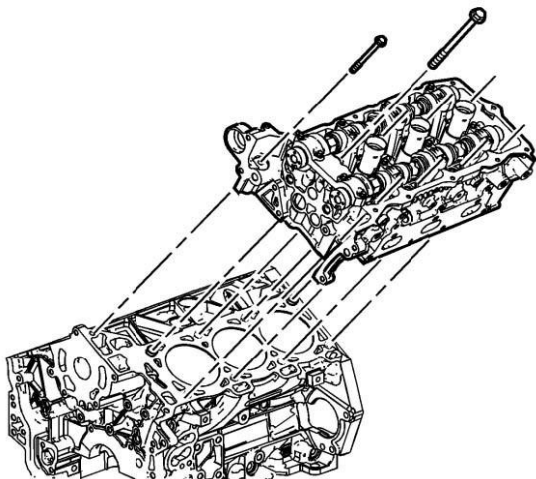

4) Install new M11 cylinder head bolts.

Tighten

4.1) Tighten the M11 cylinder head bolts (1 – 8) a first pass in sequence to 45 N·m.

4.2) Tighten the M11 cylinder head bolts a second pass in sequence an additional 120 degrees.

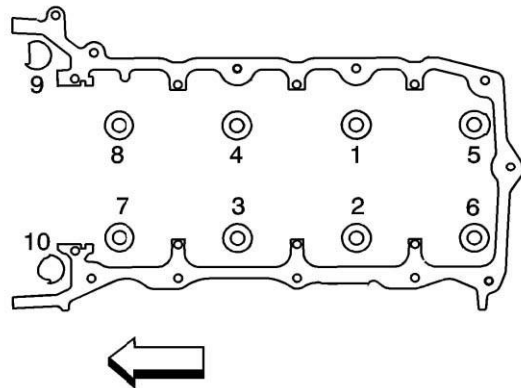

5) Install the 2 front M8 left cylinder head bolts.

Tighten

5.1) Tighten the M8 cylinder head bolts a first pass to 15 N·m (11 lb ft).

5.2) Tighten the M8 cylinder head bolts a second pass in sequence an additional 60 degrees.

Timing Chain Installation Insure all four camshafts are positioned with flats parallel to rocker cover sealing surface.

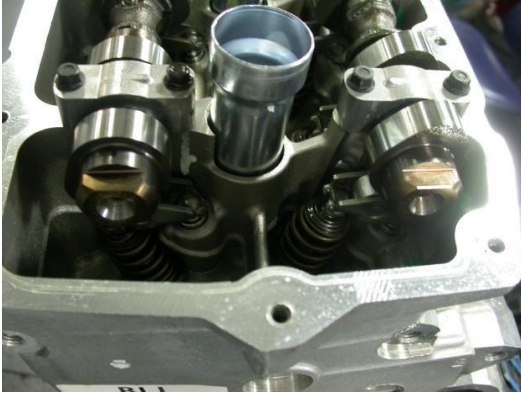

By positioning flats parallel, you assure the cam lobes are all on a portion of the base circle and the engine will thereby be a free spin so you can rotate the crankshaft without the pistons hitting the valves.

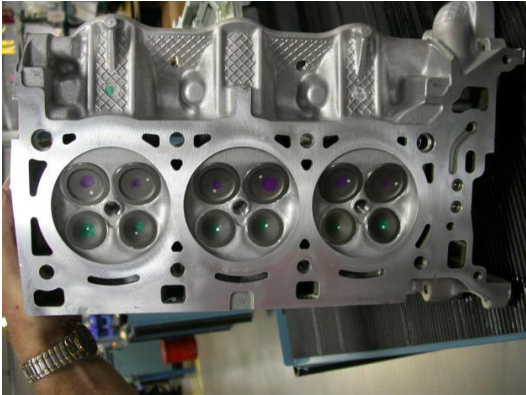

Install all four camshaft sprockets, i.e., intakes on the inside cams and exhausts on the outboard camshafts.



Left Intake



Left Exhaust



Right Intake



Right Exhaust

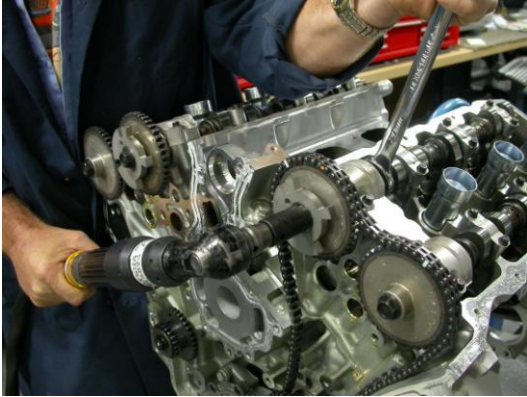

After installation you can torque all four fasteners to 58 +/- 7Nm. Holding camshafts on hex with open end wrench. Note: left side chain assembly was installed before photo taken.



Left side idler w/grenade pin.



Install left side chain guides.



Install left chain assembly with left side idler gear (do not remove grenade pin), aligning white marks on chain with dots or slots on cam gears identified as "L" Intake and "L" Exhaust on camshaft gears..



Install left side tensioner and gasket



View of left side chain assembly with grenade pin in idler gear.



Torque tensioner and chain guide fasteners to 23 +/- 3Nm.

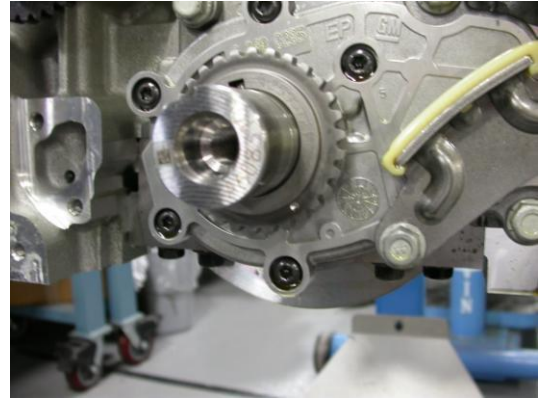

View showing left side alignment dots.



Install right side idler gear and torque to 58 +/- 7Nm.



Make sure left side idler gear still has grenade pin holding chain assembly in proper position.



Install crankshaft gear and align dot for left side chain alignment. (Phase 1) alignment step in earlier write up.



Install primary chain assembly over left, right idlers and crankshaft gears with white identification marks aligned with marks on all three gears.



View of primary chain installed.



Install primary chain guides.



Install primary chain tensioner and gasket. Install tensioner bolt with bushing. Torque tensioner and guide fasteners to 23 +/- 3Nm.



Torque right side idler gear to 58 +/- 7Nm.



Remove grenade pins from left side idler and tensioners for left side and primary chains.



Rotate crankshaft to right side alignment marks. (Phase 2 alignment).



Note white mark on crankshaft gear and alignment mark on oil pump housing.



Holding chain together, install chain guides and tensioner. Note, the right bank is the hardest chain to keep tension on during the assembly process.

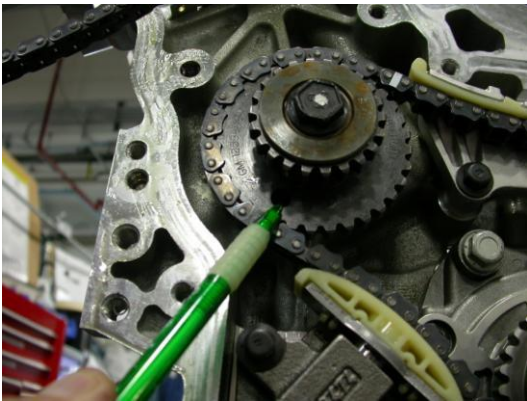

At this point, note hole in right side idler gear as noted by ink pin.



Torque tensioner and chain guides to 23 +/- 3Nm.



Align right side chain over idler with white link positioned at hole in right side idler and white marks positioned on cam gears at "R" Exhaust and "R" Intake.



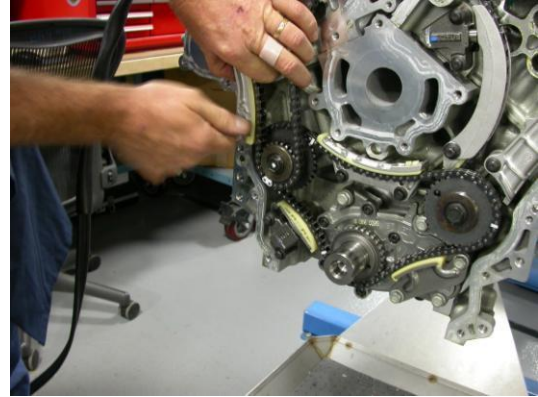
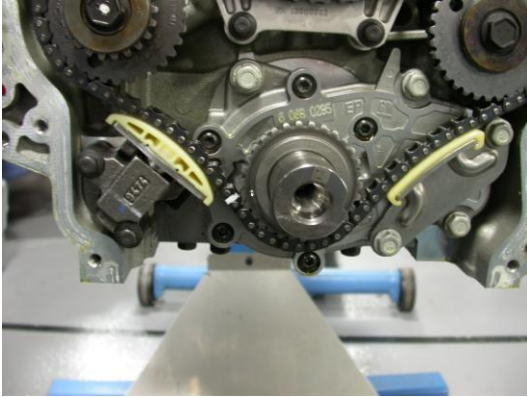

Check alignment on all four cam gears, primary chain idlers, and crank gear.

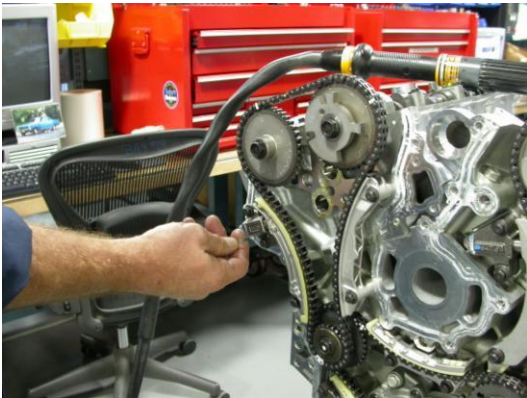

Remove grenade pin from right side chain tensioner.

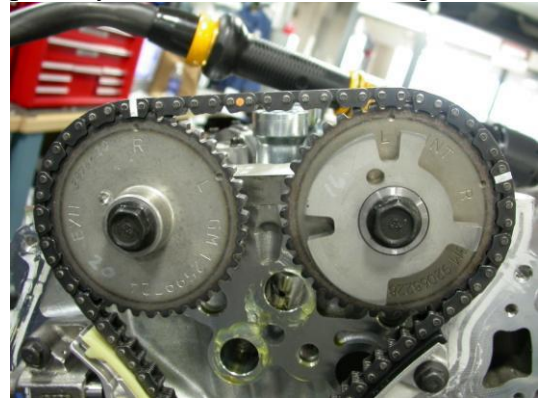

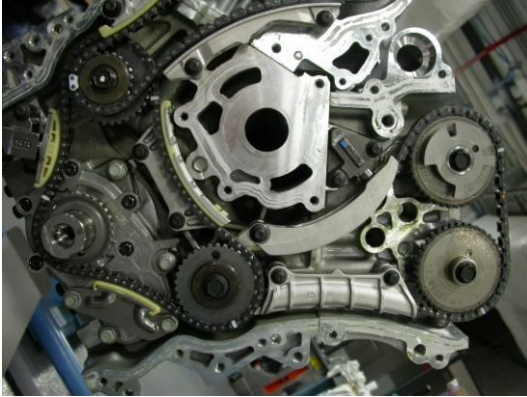

Rotate crankshaft backward (counter clockwise just past left side alignment and then back to left side alignment and check white marks for proper alignment. Rotate crankshaft clockwise to right side alignment and check marks. Make sure chain assemblies do not jump on gears.

If everything looks good, you have successfully installed the chain assembly.

Front Cover Installation

1) Install 8 mm (0.315 in) guide pins into the front cover positions at locations shown.

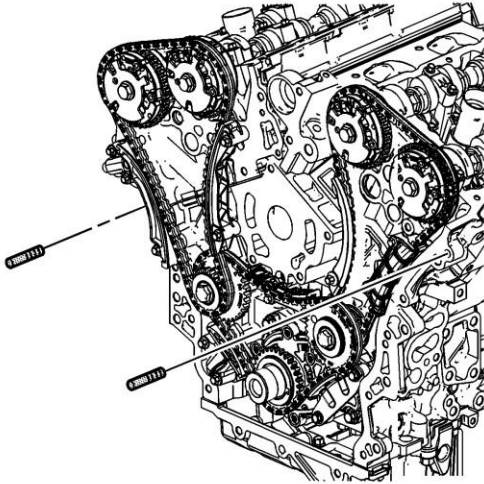

3) Place a 3 mm bead of RTV sealant, GM P/N 12378521 on the engine front cover as shown (1).

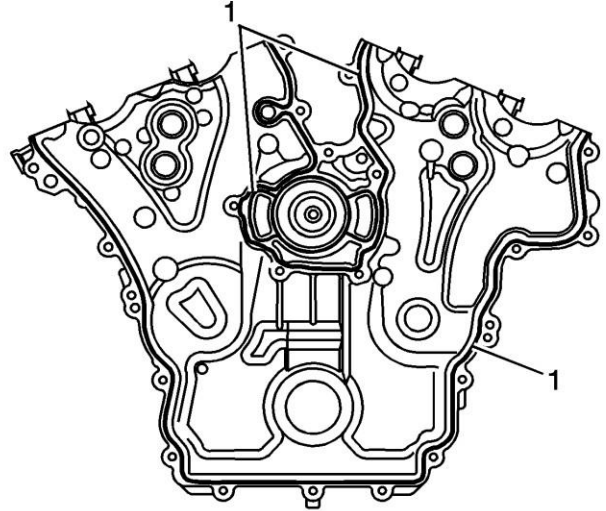

2) Inspect and/or install a NEW engine front cover to cylinder block seal if necessary.

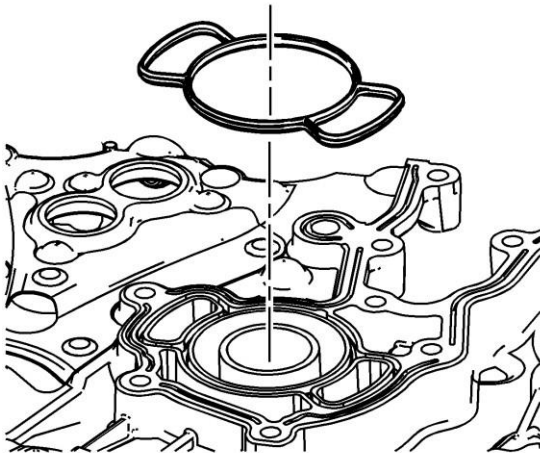

4) Place the engine front cover onto the guide pins and slide into position.

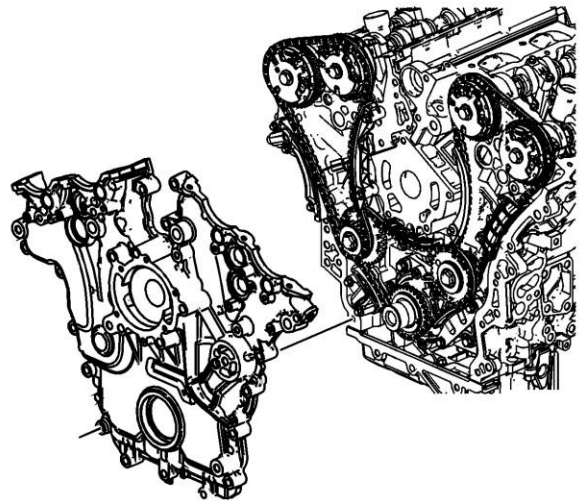

5) Loosely install the front cover bolts and install the engine front cover sound deadener.

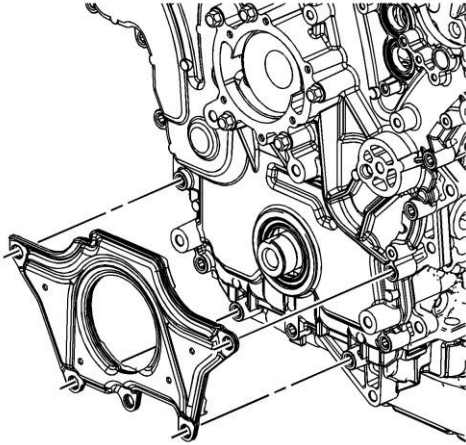

6) Tighten the engine front cover bolts in the sequence shown (1-22).

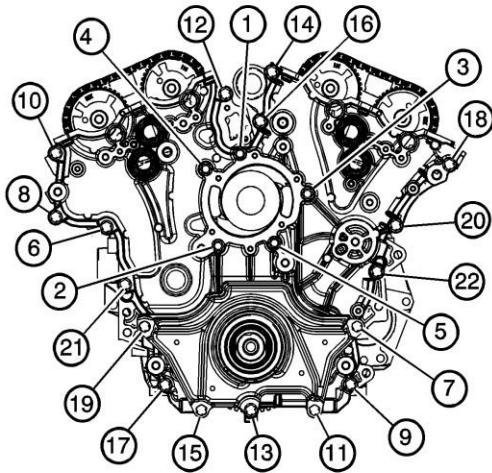

Tighten

Tighten the engine front cover bolts a first pass in sequence to 20 N·m

Tighten the engine front cover bolts a second pass in sequence an additional 60 degrees.

VERY IMPORTANT!

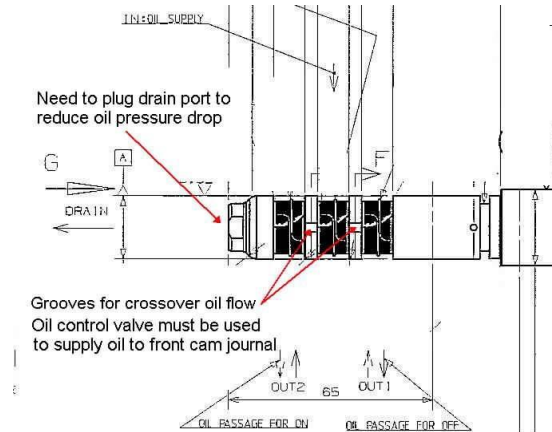

For Sequence VID test operation, the camshaft phaser oil control valves must be in place to provide lubrication to the front camshaft journals. The control valve drain ports must be welded closed to reduce excessive oil hemorrhaging through the control valves during engine operation as the valves are positioned in a manner that allows complete drainage through the spool valves.

7) Place the camshaft position actuator valves in position on the front cover.

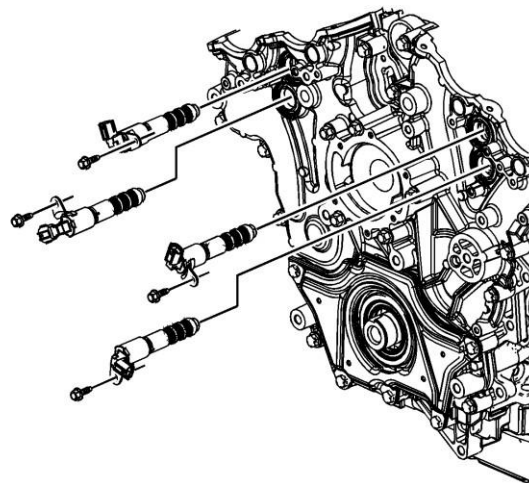

Tighten

Tighten the camshaft position actuator valve bolts to 10 N·m

8) Place the camshaft position sensors in position on the front cover.

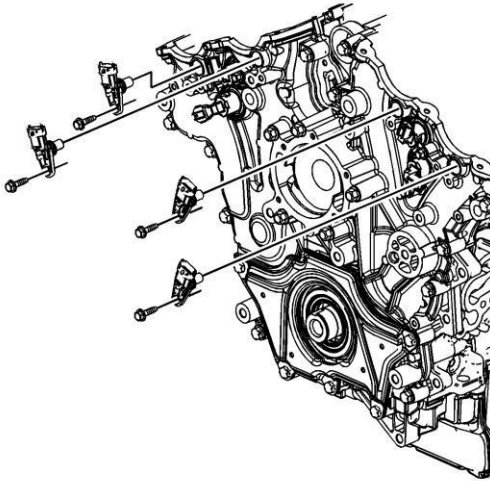
**Tighten**

Tighten the camshaft position sensor bolts to 10 N·m

Camshaft Cover Installation

1) Wipe the camshaft cover sealing surface on the left cylinder head with a clean, lint-free cloth.

Place a bead 8 mm in diameter by 4 mm in height of RTV sealant, GM P/N 12378521 or equivalent, on the engine front cover split lines (1).

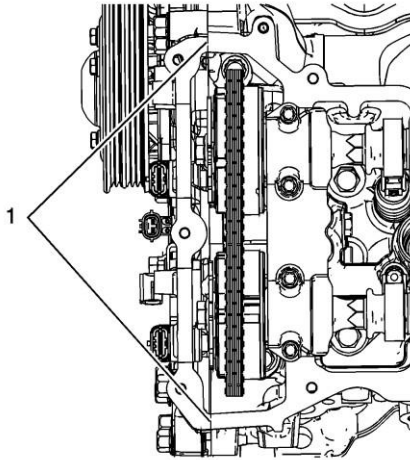

Place the left camshaft cover into position onto the left cylinder head.

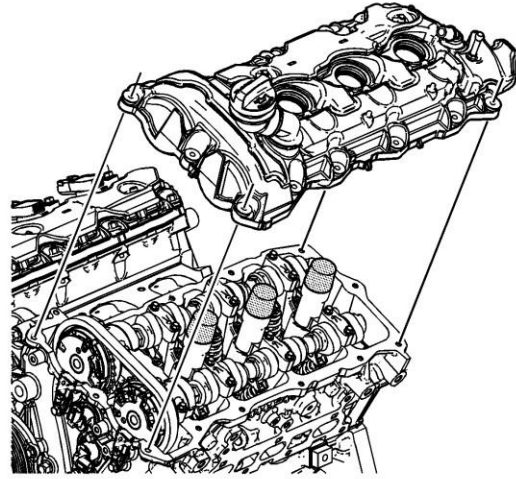

3) Tighten the left camshaft cover bolts in the sequence shown.

Tighten

Tighten the left camshaft cover bolts in the sequence to 10 N·m

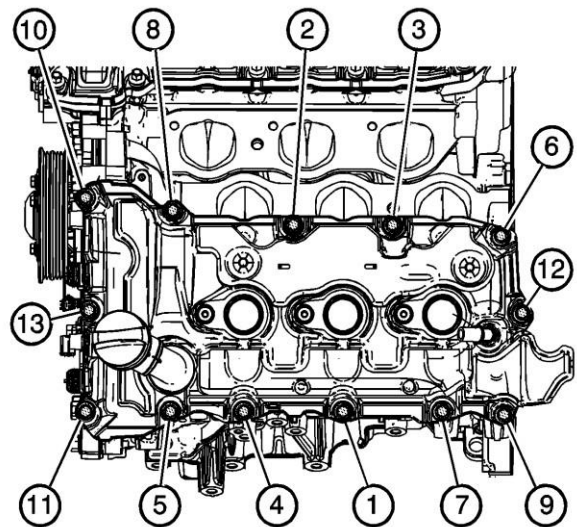

4) Install the NEW spark plugs into the left cylinder head. PN OHT6D-043-1.

Tighten

Tighten the spark plugs to 20 N·m

5)

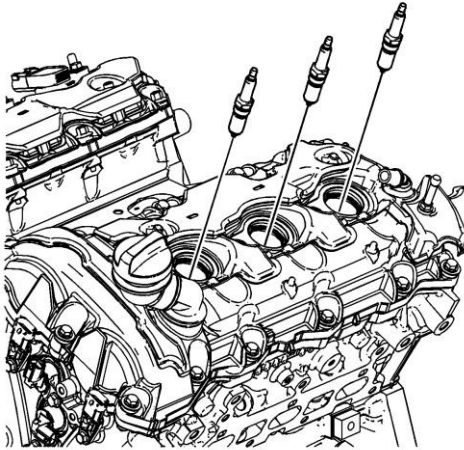

Install the ignition coils.

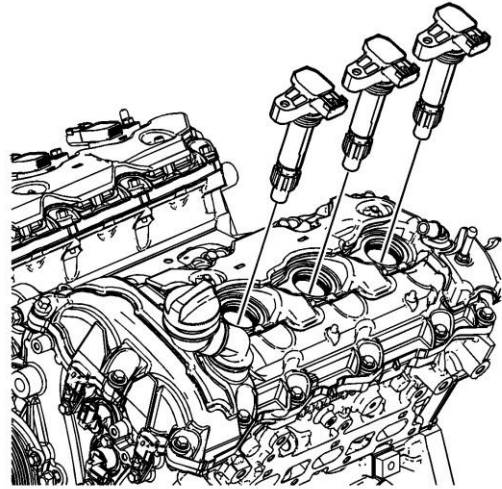

6) Tighten

Tighten the ignition coil bolts to 10 N·m

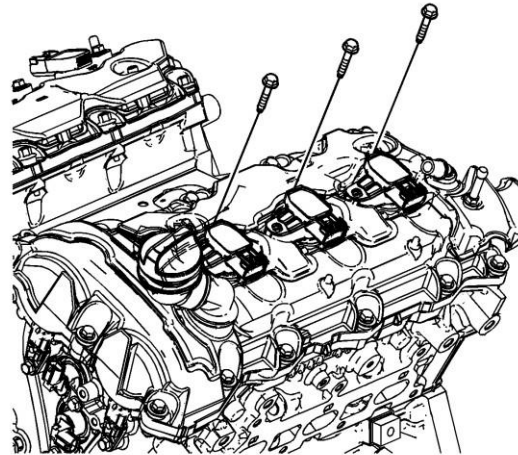

Repeat the same procedure for the right side camshaft cover

Intake Manifold Installation

1) Install the NEW intake manifold gasket

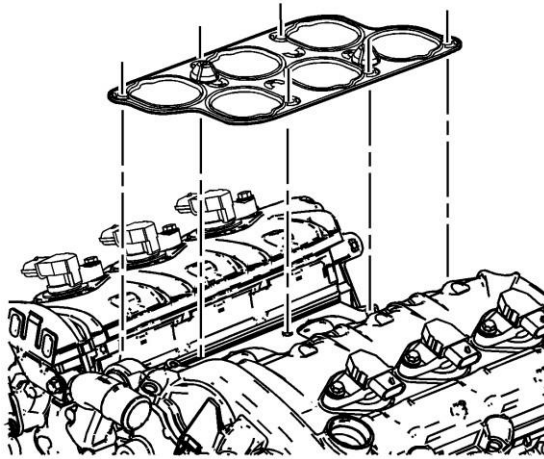

2) Install the intake manifold assembly

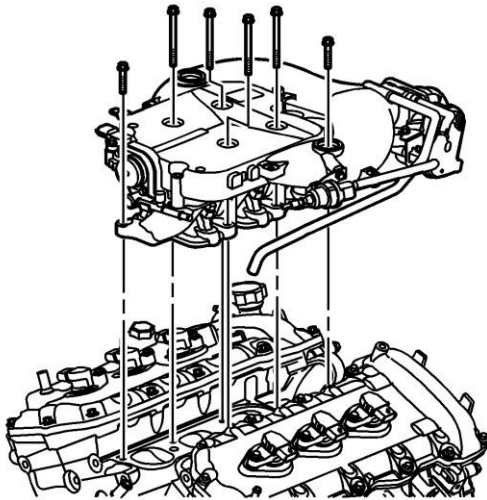

Important: Tighten the intake manifold bolts in a circular pattern starting from the center and moving outward

Tighten

Tighten the intake manifold bolts to 23 N·m

3) Place the intake manifold brace to the engine front cover and intake manifold

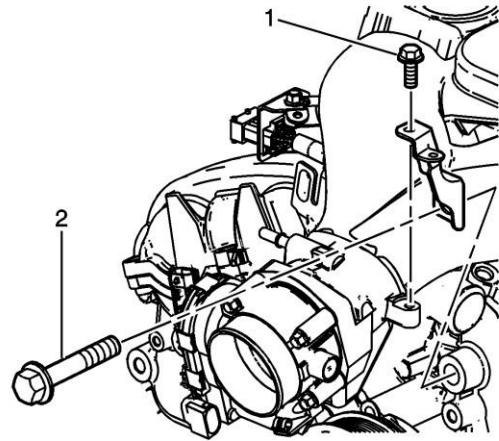

First tighten the intake manifold brace bolt (1) to the intake manifold.

Tighten

Tighten the intake manifold brace bolt at the intake manifold to 10 N·m

Finally tighten the intake manifold brace bolt (2) to the engine front cover.

Tighten

Tighten the intake manifold brace bolt to the engine front cover to 65 N·m

Attachment 1

GM Build Kit Parts

Qty	Part No.	Description
1	12650231	Timing Chain Kit
1	12646464	Gasket Kit
1	12645465	SPROCKET-CR/SHF
1	12645465	Sprocket
1	12641093	HEAD ASM-CYL (W/ VLV)(LH,LY7)
4	12636175	Solenoid
1	12641095	HEAD ASM-CYL (W/ VLV)(RH, LY7)
1	12634318	Oil Filter Gasket
1	12630223	Water Pump Gasket
1	12625923	Thermostat Gasket
1	12623514	GUIDE ASM-TMG CHAIN
1	12623513	GUIDE ASM-TMG CHAIN
1	12622550	Seal, Water Pump
1	12615626	SENSOR ASM-CR/SHF POSN
1	12612839	SPROCKET ASM,TMG CHAIN IDLER (LH)
1	12612838	SPROCKET ASM,TMG CHAIN IDLER (RH)
1	12608750	Seal, CR/SHF Front Oil
1	12600462	GUIDE ASM-TMG CHAIN
1	12600461	GUIDE ASM-TMG CHAIN
1	12597417	GUIDE ASM-TMG CHAIN
4	12593717	Seal, CM/SHF Pos Actuator sol vlv
1	12576263	Ex Man Gasket
1	12576262	Ex Man Gasket
4	12570326	Pin, Head Location
1	12566837	Oil Pump Pick-up Seal
2	11610796	Bolt
4	11588734	Head Bolt, Short
4	11588279	Bolt
6	11588255	Bolt
1	11588252	Bolt - HVY HX FLG HD Red Body
1	11569873	Crankshaft Balancer Bolt
1	11561751	Plug, Eng Block Oil Gallery
6	11561619	Bolt
16	11518863	BOLT,CYL HD
1	19206165	Block, Short HFV6

Flywheel Installation

1) Install the OHT Flywheel and new fasteners.

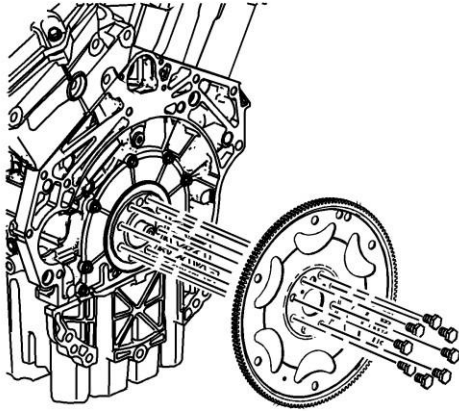

2) Install OHT Holding Fixture

View Not Shown

3) **Tighten**

Tighten the NEW engine flywheel bolts to 30 N·m

Tighten the NEW engine flywheel bolts an additional 45 degrees.

6) Remove the J 41998-B balance installation tool and install a new front balance bolt.

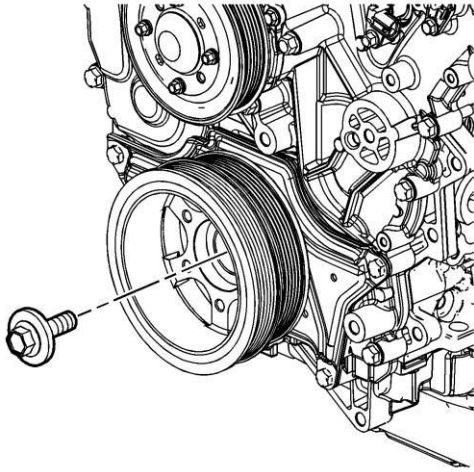

With the OHT Holding Fixture in place

Tighten

Tighten the crankshaft balancer bolt to 100 N·m

Tighten the crankshaft balancer bolt an additional 150 degrees.

VERY IMPORTANT!

The crankshaft key is not designed to carry the load for the timing chain and oil pump drive. The clamp load applied by the balancer bolt is the load carrying mechanism. If this step is not properly performed, engine failure will result.

Exhaust Manifold Installation

1) Place the right exhaust manifold, exhaust manifold gasket and bolts as an assembly in position on the right cylinder head.

Install the exhaust manifold bolts into the right cylinder head.

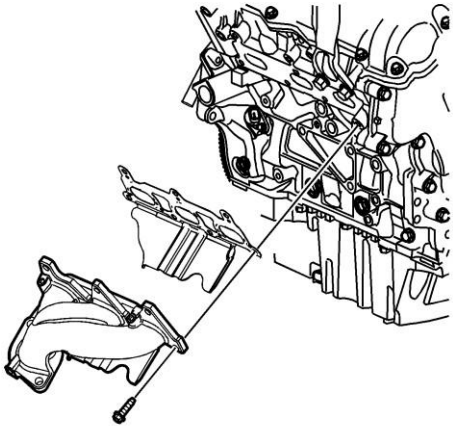

Tighten

Tighten the exhaust manifold bolts to 25 N·m

2) Place the right exhaust manifold heat shield in position

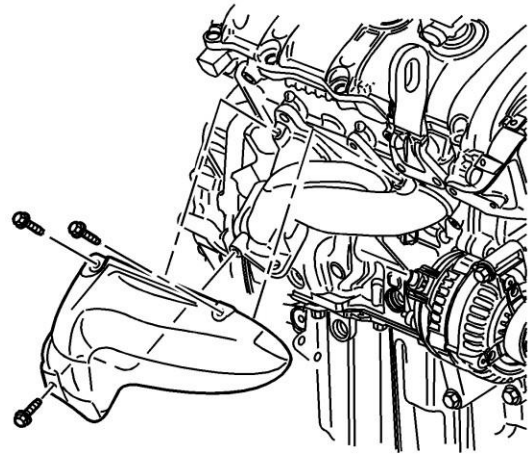

Tighten

Tighten the exhaust manifold heat shield bolts to 10 N·m

Repeat the same procedure for the left side exhaust manifold.

Front Balancer Installation

- 1) Install OHT Holding Fixture View Not Shown
- 2) Use the [J 41998-B](#), nut, bearing and washer to install the crankshaft balancer
- 3) Apply lubricant to the inside of the crankshaft balancer hub bore

Important: Do not lubricate the crankshaft front oil seal or crankshaft balancer sealing surfaces. The crankshaft balancer is installed into a dry seal.

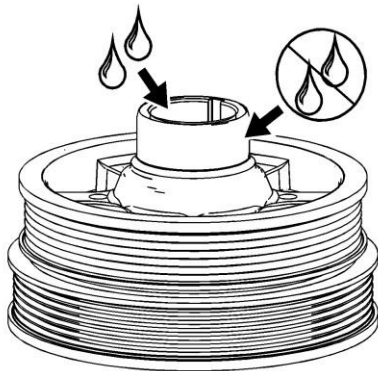

- 4) Place the crankshaft balancer in position on the crankshaft

Important: Ensure the crankshaft balancer keyway is aligned with the crankshaft key

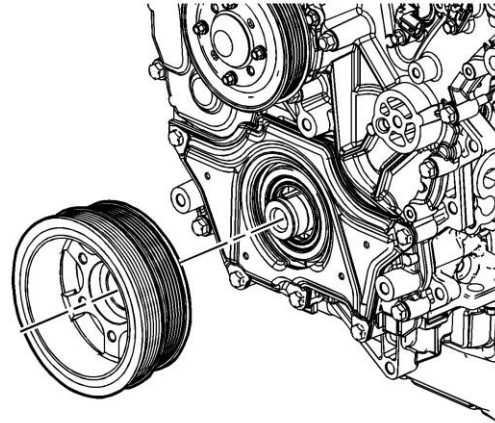

- 5) Thread the [J 41998-B](#) in the crankshaft. Ensure you engage at least 10 threads of the [J 41998-B](#) before pressing the crankshaft balancer in place. Push the crankshaft balancer into position by tightening the nut on the [J 41998-B](#) until the large washer bottoms out on the crankshaft end.

