

This Research Report is issued under the fixed designation RR:[RR #]. You agree not to reproduce or circulate or quote, in whole or part, this document outside of ASTM International Committee/Society activities, or submit it to any other organization or standards body (whether national, international or other) except with the approval of the Chairman of the Committee having jurisdiction and the written authorization of the President of the Society. If you do not agree to these conditions, please immediately destroy all copies of this document. *Copyright ASTM International, 100 Barr Harbor Drive, West Conshohocken, PA 19428. All rights reserved.*

Date RR# Approved (To be assigned by ASTM)

**Committee D02 on Petroleum Products
Subcommittee D02.B0 on Automotive Lubricants**

Research Report RR: D02-XXXX

**Interlaboratory Study to Establish Precision Statements for ASTM
D-XXXX
Standard Test Method for Measurement of Effects of Automotive
Engine Oils on Fuel Economy of Passenger Cars and Light-Duty
Trucks in Sequence VID Spark Ignition Engine**

**Technical Contact:
Charlie Leverett
Senior Engineering Technologist
Intertek Automotive Research
San Antonio, TX 78238
USA
210-684-2310
charlie.leverett@intertek.com**

ASTM International
100 Barr Harbor Drive
West Conshohocken, PA 19428-2959

1. Introduction:

An Interlaboratory Study was conducted to establish a precision statement for Sequence VID, RR: D2-XXXX, Standard Test Method for Measurement of Effects of Automotive Engine Oils on Fuel Economy of Passenger Cars and Light-Duty Trucks in Sequence VID Spark Ignition Engine.

2. Test Method:

The Test Method used for this ILS is DXXXX. To obtain a copy of DXXXX go to ASTM's website, www.astm.org, or contact ASTM Customer Service by phone at **610-832-9585** (8:30 a.m. - 4:30 p.m. Eastern U.S. Standard Time, Monday through Friday) or by email at service@astm.org.

3. Participating Laboratories:

The following laboratories participated in this interlaboratory study:

1. Intertek Automotive Research 5404 Bandera Road San Antonio, TX 78238 Charlie Leverett Senior Engineering Technologist 210-684-2310	2. Afton Chemical Corp. 500 Spring Street Richmond, VA 23218-2158 David L. Glaenzer Manager-Engine Oil Testing 804-788-5214
3. The Lubrizol Corp. 29400 Lakeland Blvd. Wickliffe, OH 44092 George Szappanos Senior Test Engineer 440-347-2352	4. SwRI 6220 Culebra Road San Antonio, TX 78238-5166 Guy Stubbs Principal Engineer 210-522-5039
5. ExxonMobil Research & Engineering Product Operations 600 Billingsport Road Paulsboro, NJ 08066-0480 Mark Mosher 856-224-2132	

4. Description of Samples: This section may will need to be revised once the Statistical Group determines which data set is used for the Precision Statement

There were three samples of varying targeted results used for this study. Each sample was randomized and distributed by ASTM Test Monitoring Center (TMC). Below is a list of the samples with the corresponding supplier:

1. Reference Oil A
Provided by ASTM, TMC
2. Reference Oil D
Provided by ASTM, TMC
3. Reference Oil X
Provided by ASTM, TMC

5. Interlaboratory Study Instructions

Laboratory participants were emailed the test program instructions. For a copy of the instructions, please see Annex A.

6. Description of Equipment/Apparatus¹:

For information on the equipment/apparatus used by each laboratory, please see Annex B, Section 6 for the VID Draft Procedure.

7. Data Report Forms:

Each laboratory was provided with a data report form for the collection of data. A summary the data collected is provided in Annex C, the full data set is available on the ASTM TMC website at the following link:

<ftp://ftp.astmtmc.cmu.edu/refdata/gas/vid/data/>

Please note: The laboratories have been randomly coded and cannot be identified herein.

8. Statistical Data Summary:

A summary of the statistics calculated from the data returned by the participating laboratories is provided in Annex D.

¹ The equipment listed was used to develop a precision statement for D-XXXX-09. This listing is not an endorsement or certification by ASTM International.

9. Precision and Bias Statement:

[Copy Precision Statement from Test Method]

ASTM International takes no position respecting the validity of any patent rights asserted in connection with any item mentioned in this research report. Users of this research report are expressly advised that determination of the validity of any such patent rights, and the risk of infringement of such rights, are entirely their own responsibility.

This research report is copyrighted by ASTM International, 100 Barr Harbor Drive, PO Box C700, West Conshohocken, PA 19428-2959, United States. Individual reprints (single or multiple copies) of this research report may be obtained by contacting ASTM at the above address or at 610-832-9585 (phone), 610-832-9555 (fax), or serviceastm.org (e-mail); or through the ASTM website (www.astm.org).

Annex A
Interlaboratory Study Instructions & Acknowledgement Documents

Charlie Leverett Intertek

From: Charlie Leverett Intertek
Sent: Monday, March 02, 2009 3:20 PM
To: Charlie Leverett Intertek; 'guy.stubbs@swri.org';
'dave.glaenzer@aftonchemical.com'; 'Mark Mosher'; Szappanos, George
Cc: 'Rich Grundza'
Subject: Sequence VID Phase II Participants

Follow Up Flag: Follow up
Due By: Monday, March 09, 2009 9:00 AM
Flag Status: Flagged

Sequence VID Phase II Participants,

According to the ASTM Template for the VID Research Report I am required to email the program instructions to all participants. The program instructions are as follows:

- 1.) Laboratories must be pre-approved to participate in Phase II by the Sequence VI Surveillance Panel, as-of issuance of this email the following are approved:
 - Afton
 - ExxonMobil
 - Intertek -AR
 - Lubrizol
 - Southwest Research Institute
- 2.) Laboratories will obtain the oil assignments from TMC, to obtain these assignments labs shall first submit the Break-in Traces as noted in Section 11.3.5 of the VID Procedure Draft 6.0 (posted on TMC Web Site).
- 3.) All tests shall follow the requirements as noted in the VID Procedure Draft 6.0 (posted on TMC Web Site).
- 4.) Laboratories are to inform TMC and the Surveillance Panel Chairman of any terminated or invalid tests ASAP.
- 5.) Laboratories will report the final results to TMC using the current version of the VID Data Dictionary (posted on TMC Web Site).

Each Laboratory shall acknowledge receipt of these requirements to the Surveillance Panel Chairman and the TMC prior to any oil assignments being issued by replying to this email stating you have read and agree to these program instructions.

If you are not the primary contact for this program please let me know who should receive this notice.

Charlie Leverett

ASTM Sequence VI Surveillance Panel Chairman
Intertek Automotive Research
Phone: 210-647-9422
Email: charlie.leverett@intertek.com

Annex B
Description of Equipment/Apparatus

This document is not an ASTM standard; it is under consideration within an ASTM technical committee but has not received all approvals required to become an ASTM standard. You agree not to reproduce or circulate or quote, in whole or in part, this document outside of ASTM Committee/Society activities, or submit it to any other organization or standards bodies (whether national, international, or other) except with the approval of the Chairman of the Committee having jurisdiction and the written authorization of the President of the Society. If you do not agree with these conditions, please immediately destroy all copies of the document. *Copyright ASTM International, 100 Barr Harbor Drive, West Conshohocken, PA 19428. All Rights Reserved.*

Designation: D XXXX-XX

[Draft #6.0 Issued 2/11/09](#)

Standard Test Method for Measurement of Effects of Automotive Engine Oils on Fuel Economy of Passenger Cars and Light-Duty Trucks in Sequence VID Spark Ignition Engine¹

This standard is issued under the fixed designation D XXXX; the number immediately following the designation indicates the year of original adoption, or in the case of revision, the year of last revision. A number in parenthesis indicates the year of last reapproval. A superscript (ϵ) indicates an editorial change since the last revision or reapproval.

INTRODUCTION

The test method described in this Draft Test Procedure is under development by the Sequence VID Test Development Consortium. This test method shall be modified as determined by the Consortium by means of Information Letters issued by the VID Test Development Manager with approval from the Chairman of Sequence VID Test Development Consortium.

1. ²³Scope

1.1 This test method covers an engine test procedure for the measurement of the effects of automotive engine oils on the fuel economy of passenger cars and light-duty 3856 kg (8500 lb) or less gross vehicle weight trucks. The tests are conducted using a specified 3.6-L (General Motors) spark-ignition engine on a dynamometer test stand. It applies to multi viscosity grade oils used in these applications.

1.2 The unit values stated in this test method shall be regarded as the standard. Values given in parentheses are provided for information purposes only. SI units are considered the primary units for this test method. The only exception is where there is no direct SI equivalent such as screw threads, national pipe threads/diameters, tubing size, and so forth.

1.3 *This Draft Test Method does not purport to address all of the safety concerns, if any, associated with its use. It is the responsibility of the user of this standard to establish appropriate safety and health practices and determine the applicability of regulatory limitations prior to use.*



1.4 This test method is arranged as follows:

Subject	Section
Introduction	
Scope	1
Referenced Documents	2
Terminology	3
Summary of Test Method	4
Significance and Use	5
Apparatus	6
General	6.1
Test Engine Configuration	6.2
Laboratory Ambient Conditions	6.3
Engine Speed and Load Control	6.4
Dynamometer	6.4.1
Dynamometer Load	6.4.2
Engine Cooling System	6.5
External Oil System	6.6
Fuel System	6.7
Fuel Flow Measurement	6.7.2
Fuel Temperature and Pressure Control to the Fuel Flowmeter	6.7.3
Fuel Temperature and Pressure Control to Engine Fuel Rail	6.7.4
Fuel Supply Pumps	6.7.5
Fuel Filtering	6.7.6
Engine Intake Air Supply	6.8
Intake Air Humidity	6.8.1
Intake Air Filtration	6.8.2
Intake Air Pressure Relief	6.8.3
Temperature Measurement	6.9
Thermocouple Location	6.9.5
AFR Determination	6.10
Exhaust and Exhaust Back Pressure Systems	6.11
Exhaust Manifolds	6.11.1
Laboratory Exhaust System	6.11.2
Exhaust Back Pressure	6.11.3
Pressure Measurement and Pressure Sensor Locations	6.12
Engine Oil	6.12.2
Fuel to Fuel Flowmeter	6.12.3
Fuel to Engine Fuel Rail	6.12.4
Exhaust Back Pressure	6.12.5
Intake Air	6.12.6
Intake Manifold Vacuum/Absolute Pressure	6.12.7
Coolant Flow Differential Pressure	6.12.8



Subject	Section
Crankcase Pressure	6.12.9
Engine Hardware and Related Apparatus	6.13
Test Engine Configuration	6.13.1
PCM (Power Control Module)	6.13.2
Thermostat/Adapter Plate	6.13.3
Intake Manifold	6.13.4
Flywheel	6.13.5
Wiring Harness	6.13.6
Oil Pan	6.13.8
Oil Pump Screen and Pickup Tube	6.13.9
Engine Water Pump Adapter Plate	6.13.11
Thermostat Housing	6.13.12
Oil Filter Adapter	6.13.13
Fuel Rail	6.13.14
Miscellaneous Apparatus Related to Engine Operation	6.14
Reagents and Materials	7
Engine Oil	7.1
Test Fuel	7.2
Engine Coolant	7.3
Cleaning Materials	7.4
Preparation of Apparatus	8
Test Stand Preparation	8.2
Engine Preparation	9
Cleaning of Engine Parts	9.2
Engine Assembly Procedure	9.3
General Assembly Instructions	9.3.1
Sealing Compounds	9.3.3
Harmonic Balancer	9.3.5
Oil Pan	9.3.6
Intake Manifold	9.3.7
Camshaft Covers	9.3.8
Thermostat Housing	9.3.10
Coolant Inlet	9.3.11
Oil Filter Adapter	9.3.12
Dipstick Tube	9.3.13
Water Adapter Plate	9.3.14
Sensors, Switches, Valves, and Positioner's	9.3.15
Ignition System	9.3.16
Fuel Injection System	9.3.17



Subject	Section
Intake Air System	9.3.18
Accessory Drive Units	9.3.20
Exhaust Manifolds	9.3.21
Engine Flywheel and Guards	9.3.22
Lifting of Assembled Engines	9.3.23
Engine Mounts	9.3.24
Calibration	10
Stand/Engine Calibration	10.1
Procedure	10.1.1
Reporting of Reference Results	10.1.2
Analysis of Reference/Calibration Oils	10.1.3
Instrument Calibration	10.2
Engine Load Measurement System	10.2.1
Fuel Flow Measurement System	10.2.2
Coolant Flow Measurement System	10.2.3
Thermocouple and Temperature Measurement System	10.2.4
Humidity Measurement System	10.2.5
Other Instrumentation	10.2.6
Test Procedure	11
Preparation for Initial Start-up of New Engine	11.1
External Oil System	11.1.1
Flush Effectiveness Demonstration	11.1.2
Preparation for Oil Charge	11.1.3
Oil Charge for Coolant Flush	11.1.4
New Engine Break-In	11.4
Oil Charge for Break-In	11.4.2
Break-In Operating Conditions	11.4.3
Routine Test Operation	11.5
Start-Up and Shutdown Procedures	11.5.8
Flying Flush Oil Exchange Procedures	11.5.9
Test Operating Stages	
Stabilization to Stage Conditions	
Stabilized BSFC Measurement Cycle	
Data Logging	11.5.13
BL Oil Flush Procedure for BL Oil Before Test Oil	11.5.14
BSFC Measurement of BL Oil Before Test Oil	11.5.15
Test Oil Flush Procedure	11.5.16
Test Oil Aging	11.5.17
BSFC Measurement of Aged (Phase I) Test Oil	11.5.18



Subject	Section
Aging Phase II	11.5.19
BSFC Measurement of Aged (Phase II) Test Oil	11.5.21
BL Oil Flush Procedure for BL Oil After Test Oil	11.5.22
BSFC Measurement for BL Oil After Test Oil	11.5.23
General Test Data Logging Forms	11.5.24
Diagnostic Review Procedures	11.5.25
Determination of Test Results	12
Precision and Bias	14
Keywords	15
Annexes	
Detailed Specifications and Drawings of Apparatus	Annex A2
Oil Heater Cerrobase Refill Procedure	Annex A3
Engine Part Number Listing	Annex A4
Safety Precautions	Annex A5
Report Format	Annex A6
Statistical Equations for Mean and Standard Deviations	Annex A7
Oil Sump Full Level Determination Consumption Measurement Calibration Procedure	Annex A8
Fuel Injector Evaluation	Annex A9
Pre-test Maintenance Checklist	Annex A10
Blow-by Ventilation System Requirements	Annex A11
Appendix	
Procurement of Test Materials	Appendix X1

2. Referenced Documents

2.1 ASTM Standards:

- D 86 Test Method for Distillation of Petroleum Products at Atmospheric Pressure
- D 235 Specification for Mineral Spirits (Petroleum Spirits) (Hydrocarbon Dry Cleaning Solvent)
- D 240 Test Method for Heat of Combustion of Liquid Hydrocarbon Fuels by Bomb Calorimeter



- D 323 Test Method for Vapor Pressure of Petroleum Products (Reid Method)
- D 381 Test Method for Gum Content in Fuels by Jet Evaporation
- D 445 Test Method for Kinematic Viscosity of Transparent and Opaque Liquids (and the Calculation of Dynamic Viscosity)
- D 525 Test Method for Oxidation Stability of Gasoline (Induction Period Method)
- D 1319 Test Method for Hydrocarbon Types in Liquid Petroleum Products by Fluorescent Indicator Adsorption
- D 2699 Test Method for Research Octane Number of Spark-Ignition Engine Fuel
- D 3231 Test Method for Phosphorus in Gasoline
- D 3237 Test Method for Lead in Gasoline by Atomic Absorption Spectroscopy
- D 3338 Test Method for Estimation of Net Heat of Combustion of Aviation Fuels
- D4052 Test Method for Density and Relative Density of Liquids by Digital Density Meter
- D 4485 Specification for Performance of Engine Oils
- D5185 Test Method for Determination of Additive Elements, Wear Metals, and Contaminants in Used Lubricating Oils and Determination of Selected Elements in Base Oils by Inductively Coupled Plasma Atomic Emission spectrometry (ICP-AES)
- D5453 Test Method for Determination of Total Sulfur in Light Hydrocarbons, Spark-Ignition Engine Fuel, Diesel Engine Fuel, and Engine Oil by Ultraviolet Fluorescence
- D 5862 Test Method for Evaluation of Engine Oils in Two-Stroke Cycle Turbo-Supercharged 6V92TA Diesel Engine
- D 6202 Test Method for Automotive Engine Oils on the Fuel Economy of Passenger Cars and Light-Duty Trucks in the Sequence VIA Spark Ignition Engine
- D 6837 Test Method for Automotive Engine Oils on the Fuel Economy of Passenger Cars and Light-Duty Trucks in the Sequence VIB Spark Ignition Engine
- D 6557 Test Method for Evaluation of Rust Preventive Characteristics of Automotive Engine Oils
- E 29 Practices for Using Significant Digits in Test Data to Determine Conformance with Specifications
- E 191 Specifications for Apparatus for Microdetermination of Carbon and Hydrogen in Organic and Organo-Metallic Compounds
- IEEE/ASTM SI-10 Standard for Use of the International System of Units (SI): The Modern Metric System
 - 2.2 *SAE Standards:*
- J304 Engine Oil Tests
- J1423 Classification of Energy-Conserving Engine Oil for Passenger Cars and Light-Duty Trucks
 - 2.3 *API Publication*
- API 1509 Engine Oil Licensing and Certification System
 - 2.4 *ANSI Standard:*
- ANSI MC96.1-1975 Temperature Measurement – Thermocouples

3. Terminology

3.1 *Definitions:*

3.1.1 *aged test oil, n*—an engine oil to be tested that has been previously subjected to use in a spark-ignited operating engine for a prescribed length of service under prescribed conditions. Source D 6837



3.1.2 *aging*, *n*—the subjecting of an engine oil to use in a spark-ignited operating engine for a prescribed length of service under prescribed conditions. Source D 6837

3.1.3 *air-fuel ratio*, *n*—*in internal combustion engines*, the mass ratio of air-to-fuel in the mixture being induced into the combustion chambers - source D 5302

3.1.4 *automotive*, *adj*—descriptive of equipment associated with self-propelled machinery, usually vehicles driven by internal combustion engines – source D 4485

3.1.5 *blowby*, *n*—*in internal combustion engines*, the combustion products and unburned air-and-fuel mixture that enter the crankcase – source D 5302

3.1.6 *break-in*, *v*—*in internal combustion engines*, the running of a new engine under prescribed conditions to help stabilize engine response and help remove initial friction characteristics associated with new engine parts. Source D 6837

3.1.7 *calibrate*, *v*—to determine the indication or output of a measuring device or a given engine with respect to a standard. source D 5862

3.1.8 *calibration oil*, *n*—an oil that is used to determine the indication or output of a measuring device or a given engine with respect to a standard. Source D 6202

3.1.9 *engine oil*, *n*—a liquid that reduces friction or wear, or both, between the moving parts of an engine; removes heat, particularly from the underside of pistons; and serves as a combustion gas sealant for the piston rings. Source D 5862

3.1.10 *central parts distributor (CPD)*, *n*—the manufacturer or supplier, or Both, of many of the parts and fixtures used in this test method. Source D 6837

3.1.10.1 *Discussion*—Because of the need for availability, rigorous inspection, and control of many of the parts used in this test method, companies having the capabilities to provide the needed services have been selected as the official suppliers for the Sequence VID test method. These companies work closely with the Test Procedure Developer and with the ASTM groups associated with the test method to help ensure that the critical engine parts used in this test method are available to the testing industry and function satisfactorily.

3.1.11 *flush*, *v*—to wash out with a rush of engine oil, during a prescribed mode of engine operation to minimize carryover effect from the previous oil and remove residues, before introducing new test oil. Source D 6837

3.1.12 *flying flush*, *n*—*in internal combustion engines*, the washing out with a rush of engine oil, during a prescribed mode of engine operation to minimize carryover effect from the previously used oil and remove residues without stopping the engine after the previous test. Source D 6837

3.1.13 *fuel economy*, *n*—*in internal combustion engines*, the efficient use of gasoline. Source D 6837

3.1.13.1 *Discussion*—Determined by comparing the rate of fuel consumption of a test oil with that displayed by baseline oil.

3.1.14 *lubricant*, *n*—any material interposed between two surfaces that reduces the friction or wear, or both, between them. Source D 5862

3.1.15 *non-reference oil*, *n*—any oil other than a reference oil, such as a research formulation, commercial oil, or candidate oil. Source D 6837

3.1.16 *non-standard test*, *n*—a test conducted with operating conditions (that is, engine speeds, loads, temperatures, and so forth) outside the normal test operating conditions or with a fuel other than the specified test fuel or with non-specified hardware configuration. Source D 6837

3.1.17 *purchaser*, *n*—*of an ASTM test*, a person or organization that pays for the conduct of an ASTM test method on a specified product.



3.1.17.1 *Discussion*—The preferred term is purchaser. Deprecated terms that have been used are client, requester, sponsor, and customer. Source D 6202

3.1.18 *reference oil, n*—an oil of known performance characteristics used as a basis for comparison. Source D 6837

3.1.19 *test oil, n*—any oil subjected to evaluation in an established procedure. Source D 6557

3.1.20 *test start, n*—introduction of test oil into the engine. Source D 6837

3.2 *Definition of Term Specific to This Standard:*

3.2.9 *Off test time, n*—time when the test is not operating at the scheduled test conditions, but shutting down the engine is not required.



4. Summary of Test Method

4.1 The 3.6-L internal combustion engine is installed on a dynamometer test stand equipped with the appropriate controls for speed, load, and various other operating parameters.

4.2 The test method consists of measuring the laboratory engine brake specific fuel consumption at 6 constant speed/load/temperature conditions for the baseline calibration oil, test oil, and a repeat of the baseline calibration oil. The approximate test length is 155 h.

4.3 Aged test oil is compared directly to fresh VID BL (baseline oil) SAE 20W-30 (see X1.2) baseline calibration oil, which is run before and after the test oil. When changing from test oil to baseline oil, an intermediate flush with special flushing oil (BL with 5 X Detergent package or FO) is required to minimize the possibility of a carryover effect from the previous oil.

4.4 Test results are expressed as a percent change in weighted fuel consumption (see Table 6) relative to the baseline calibration oil.

5. Significance and Use

5.1 *Test Method*—The data obtained from the use of this test method provide a comparative index of the fuel-saving capabilities of automotive engine oils under repeatable laboratory conditions. A BL has been established for this test to provide a standard against which all other oils can be compared. The BL oil is an SAE 20W-30 grade fully formulated lubricant. The test procedure was not designed to give a precise estimate of the difference between two test oils without adequate replication. The test method was developed to compare the test oil to the BL oil. Companion test methods used to evaluate engine oil performance for specification requirements are discussed in the latest revision of Specification D 4485.

5.2 *Use*—The Sequence VID test method is useful for engine oil fuel economy specification acceptance. It is used in specifications and classifications of engine lubricating oils, such as the following:

5.2.1 Specification D 4485.

5.2.2 API Publication 1509.

5.2.3 SAE Classification J304.

5.2.4 SAE Classification J1423.

6. Apparatus

6.1 *General*—Standardize certain aspects of each test stand in terms of stand hardware. Examples of components that are specified are certain pumps, valves, heat exchangers, heaters, and piping nominal inside diameter (I.D.). Where specified, four classes or categories of stand hardware have been designated:

6.1.1 Prints/photos for special parts are included in this procedure. Substitution of equivalent equipment is allowed, but only after equivalency has been proven acceptable by the Sequence VI Surveillance Panel.

6.2 *Test Engine Configuration*—The test engine is a specially built General Motors (GM) 3.6 L (LY7) engine. Mount the engine on the test stand so that the flywheel friction face is $3.0 \pm 0.5^\circ$ from the vertical with the front of the engine higher than the rear. The driveshaft angle shall be $1.5^\circ \pm 0.5^\circ$ from engine to dynamometer. The driveshaft angle shall be $0^\circ \pm 0.5^\circ$ in the horizontal plane.



6.3 *Laboratory Ambient Conditions*—Do not permit air from fans or ventilation systems to blow directly on the engine. The ambient laboratory atmosphere shall be relatively free of dirt, dust, or other contaminants as required by good laboratory standards.

6.4 *Engine Speed and Load Control*—The dynamometer speed and load control systems shall be capable of maintaining the limits specified in Tables 2–4. The VID closed-loop control system maintains speed by electronic throttle and load by dynamometer control. Since these speed and load tolerances require sensitive and precise control, give particular attention to achieving and maintaining accurate calibration of the related instrument systems.

6.4.1 *Dynamometer*—Use a Midwest or Eaton 37 kW (50-hp) Model 758 dry gap dynamometer (see X1.4). Replacing an engine dynamometer during a test (reference or non-reference oil) is not acceptable. If a dynamometer needs to be replaced during a test, abort the test. Follow calibration requirements shown in Section 10.4.1 before starting each new test.

6.4.2 *Dynamometer Load:*

6.4.2.1 *Dynamometer Load Cell*—Measure the dynamometer load by a 0 to 45 kg (0 to 100 lb) load cell. The dynamometer load cell is required to have the following features:

(1) Good temperature stability:

Zero ≤ 0.0036 % FSO (Full Scale Output) per °C (0.002 % FSO per °F), and

Span ≤ 0.0036 % FSO per °C (0.002 % FSO per °F).

(2) Nonlinearity ≤ 0.05 % FSO.

(3) Temperature compensation over range expected in laboratory (21 to 77°C) (70 to 170°F). A Lebow Model 3397 load cell (see X1.5) has been found suitable for this application.

6.4.2.2 *Dynamometer Load Cell Damper*—Do not use a load cell damper.

6.4.2.3 *Dynamometer Load Cell Temperature Control*—Control the load cell temperature. Enclose the dynamometer load cell to protect it from the variability of laboratory ambient temperatures. Maintain air in the enclosure within the operating temperature range specified by the load cell manufacturer within a variability of no more than $\pm 6^\circ\text{C}$ ($\pm 10.8^\circ\text{F}$). Control temperature by a means that does not cause uneven temperatures on the body of the load cell.

6.4.2.4 *Dynamometer Connection to Engine*—Use a damper system or damped shaft with U-joints for the dynamometer-to-engine connection (see 6.2). The following have been found suitable and are currently used; Vulkan, Machine Service Inc. (X1.31)

6.5 *Engine Cooling System*—Use an external engine cooling system, as shown in Figs. A2.1–A2.5, to maintain the specified jacket coolant temperature and flow rate during the test. An alternative cooling system is shown in Fig. A2.3. The systems shall have the following features:

6.5.1 Pressurize the coolant system at the top of the reservoir. Control the system pressure to 70 ± 10 kPa. Install a pressure cap or relief valve (PC-1 in Figs. A2.1–A2.3) (see X1.6) capable of maintaining system pressure within the above requirements.



6.5.2 The pumping system shall be capable of producing 80 ± 4 L/min. A Gould's G&L centrifugal pump (P-1 in Figs. A2.1–A2.3), Model NPE, Size 1ST, mechanical seal, with a 2-hp, 3450-r/min motor, have been found suitable for this application (see X1.7). Voltage and phase of the motor is optional. VFD [variable frequency drive] devices are acceptable in this application.

6.5.3 The coolant system volume is not specified; however certain cooling system components are specified as shown in Figs.A2.1–A2.3. Adhere to the nominal I.D. of the line sizes as shown in Figs.A2.1–A2.3.

6.5.4 The specified heat exchanger (HX-1 in Figs. A2.1–A2.3) is an ITT Standard brazed plate model 320-20, Part No. 5-686-06-020-001 or ITT Bell and Gossett brazed plate model BP-75H-20, Part No. 5-686-06-020-001 (see X1.8). Parallel or counter flow through the heat exchanger is permitted.

6.5.4.1 Approved replacement heat exchangers are: ITT Bell and Gossett brazed plate Model BP-420-20, Part No. 5-686-06-020-005 and ITT Bell and Gossett brazed plate Model BP-422-20, Part No. 5-686-06-020-007.

6.5.4.2 The specified heat exchanger(s) for the alternative cooling system (see Fig. A2.3) are an ITT shell and tube Model BCF 5-030-06-048-001 or an American Industrial AA-1248-3-6-SP.

6.5.5 An orifice plate (OP-1 in Figs. A2.1–A2.3) is specified. It is recommended that the orifice plate be sized to provide a pressure drop equal to that of heat exchanger HX-1 and install it in the bypass loop of the coolant system.

6.5.5.1 An orifice plate (OP-1) is not required when using the alternative cooling system (see Fig.A2.3).

6.5.6 An orifice plate (differential pressure) (FE-103 in Figs. A2.1–A2.3) is specified (see X1.9). Use an orifice flange, 1 1/2 NPT. Size the orifice plate to yield a pressure drop of 11.21 ± 0.50 kPa (45.0 ± 2.0 in.H₂O) at a flow rate of 80 L/min (21.1 gal/min). There shall be 10 diameters upstream and 5 diameters downstream of straight, smooth pipe with no reducers or increasers. Flange size shall be the same size as pipe size. Threaded, slip-on or weld neck styles can be used as long as a consistent pipe diameter is kept throughout the required lengths. An orifice obtained from Flowell (see X1.9) has been found suitable.

6.5.7 A control valve (TCV-104 in Figs. A2.1–A2.3) is required for controlling the engine coolant flow rate through the heat exchanger, HX-1, and the heat exchanger bypass portion of the cooling system. A VFD device would not require this valve.

6.5.7.1 A Badger Meter Inc. Model No. 9003TCW36SV3AxxL36 (air-to-close), or Model No. 9003TCW36SV1AxxL36 (air-to-open) 3-way globe (divert), 2-in. valve is the specified valve (see X1.10). A VFD device would not require this valve.

6.5.7.2 A Badger Meter Inc. Model No. 9003TCW36SV3A29L36 (air-to-close), or Model No. 9003TCW36SV1A29L36 (air-to-open) are also acceptable if the trim package used with these valves has a CV of 16.0.



6.5.7.3 Install the valve in a manner so that loss of air pressure to the controller results in coolant flow through the heat exchanger rather than through the coolant bypass (fail safe). Air-to-open/air-to-close is optional.

6.5.7.4 Control valve (TCV104) is not required when using the alternative cooling system (see Fig.A2.3).

6.5.8 A control valve (FCV-103 in Figs. A2.1–A2.3) is required for controlling the coolant flow rate to 60.0 ± 4 L/min (13 ± 1 gal/min). A Badger Meter Inc. Model No. 9003GCW36SV3A29L36, 2-way globe, 2-in., air-to-close valve is the specified valve (see X1.10).

6.5.9 Use a Viatran model 274/374, Validyne model DP15 or P55, or Rosemount model 1151 differential pressure transducer (DPT-1 in Fig. A2.3) for reading the coolant flow rate at the orifice plate (FE-103 in Figs. A2.1–A2.3) (see X1.11).

6.5.10 Replace the engine water pump with a water pump plate OHT-6D-005-1, shown in Fig. A2.4.

6.5.11 A coolant reservoir, a coolant overflow container, and a sight glass are required as shown in Figs. A2.1–A2.3 and Fig. A2.5. The design or model of these items is optional.

6.5.12 Use a control valve (TCV-101 in Fig. A2.1 and Fig. A2.2) for controlling the process water flow rate through the heat exchanger HX-1. A Badger Meter Inc. Model 9001GCW36SV3Axxx36 (air-to-close) or Model 9001GCW36SV1Axxx36 (air-to-open), 2-way globe, 1-in. valve is the specified valve (see X1.10). The type of trim package that may be used with this valve is optional.

6.5.13 Use a 1 1/2-in. NPT sight glass in the main coolant circuit (SG-1 in Figs. A2.1–A2.3). The make/model is optional.

6.5.14 Brass, copper, galvanized or stainless steel materials are recommended for hard plumbing in the coolant system.

6.5.15 The materials used for process water, hot water, chilled water, process air, engine coolant overflow, and engine coolant transducer tubing are at the discretion of the laboratory.

6.5.16 The system shall have provisions (for example, low point drains) for draining all of the flushing water prior to installing a new coolant mixture.

6.6 *External Oil System*—An external oil system as shown in Figs. A2.6- A2.10 is required. Although all of the systems are interconnected in some manner, the overall external oil system is comprised of two separate circuits: (1) the flying flush system, which allows the oil to be changed while the engine is running, and (2) the circulation system for oil temperature control. The engine oil pan (OHT-6D-001-1) shown in Fig. A2.9 shall be considered a part of the external oil system. Minimize the external oil volume of all of the circuits as well as the length of connections and surfaces which are in-contact with more than one oil in the flush system to enable more thorough flying flushes (see X1.23).



6.6.1 The flush system has a high capacity scavenge pump, which flows into a minimum 6.0-L (6.34-qt) capacity dump reservoir while fresh oil is drawn into the engine. The dump reservoir float switch then resets certain solenoids and the engine refills to the level established by the float switch in the engine oil pan (which then closes the solenoid to the fresh oil reservoir).

6.6.2 The oil heat/cool loop uses a proportional controller to bypass the cooling heat exchanger. Control the temperature within narrow limits with minimal additional heat (and surface temperatures). The system can respond quickly to establish the different oil gallery temperatures required in the procedure. Arrange the proportional three-way control valve to go to its mid-point during the flying flushes to avoid trapping oil, and there shall be some cooling during test oil aging so that no oil is trapped in the cooler.

6.6.3 Do not use cuprous materials in any of the oil system (excluding the oil scavenge discharge system) except as may be required by the use of mandatory equipment in this procedure.

6.6.4 The flying flush system (see Fig. A2.6) shall have the following features:

6.6.4.1 A scavenge pump, Viking Series 475, gear type, close-coupled pump, model H475M is specified (see X1.13). The pump shall have an 1140 to 1150-r/min electric motor drive with a minimum of 0.75 hp. Voltage and phase are optional.

6.6.4.2 A reservoir with a minimum capacity of 19 L (5 gal). It is recommended that the system include three reservoirs, one for BL calibration oil, one for FO -flush oil, and one for test oil.

6.6.4.3 An oil stirrer in each oil reservoir.

6.6.4.4 An oil heating system (with appropriate controls) for each oil reservoir with the capability of heating the oil in the reservoir to $107 \pm 2.8^{\circ}\text{C}$ ($224.6 \pm 5^{\circ}\text{F}$).

6.6.4.5 A dump reservoir (see Fig.A2.8) with a minimum 6-L (6.34-qt) capacity.

6.6.4.6 A dump reservoir float switch is required. (FLS-136 in Figs A2.8) The make and model is optional. A Gems Series ALS79999, Catalog No. A79999, 20 VA, high temperature float switch has been found suitable for this application (see X1.23).

6.6.5 The circulation system for oil temperature control shall have the following features:

6.6.5.1 A total volume, including oil volume in the oil pan to the full mark, shall be 5.4 L (5.71 qt).

6.6.5.2 -Use a positive displacement oil circulation pump. A Viking Series 4125, Model G4125, no relief valve, base-mounted is specified (see X1.15). The pump shall have a V-belt or direct drive 1140 to 1150-r/min electric drive motor with a minimum of 0.56 Kw (0.75 hp). Voltage and phase are optional.

NOTE 1: The explosion proof requirement for the motor is left to the discretion of the laboratory.

NOTE 2: Either V-belt drive or direct-coupled drive may be used. If V-belt drive is used, use a 1:1 pulley ratio so that the final speed of the pump is a nominal 1150 r/min.



6.6.5.3 Use solenoid valves (FCV-150A, FCV-150C, FCV-150D, and FCV-150E, in Figs. A2.6) (see X1.16).

(1) FCV-150F and its related lines/piping are optional.

(2) FCV-150A is a Burkert Type 251 piston-operated valve used with a Type 312 solenoid valve (or a Burkert Type 2000 piston-operated valve used with a Type 311 or 330 solenoid valve) for actuation of air supply to the piston valve, solenoid valve direct-coupled to piston valve, normally closed, explosion proof (left to the discretion of the laboratory), and watertight, 3/4 in., 2-way, stainless steel NPT fitting.

(3) FCV-150C is a Burkert Type 251 piston-operated valve used with a Type 312 solenoid valve (or a Burkert Type 2000 piston-operated valve used with a Type 311, 312 or 330 solenoid valve) for actuation of air supply to the piston valve, solenoid valve direct-coupled to the piston valve, normally open, explosion proof (left to the discretion of the laboratory) and watertight, 12.7mm (1/2 in.), 2-way, stainless steel NPT fitting.

(4) FCV-150D, FCV-150E, and FCV-150F are Burkert Type 251 piston-operated valves used with a Type 312 solenoid valve (or a Burkert Type 2000 piston-operated valve used with a Type 311, 312 or 330 solenoid valve) for actuation of air supply to the piston valve, solenoid valve direct-coupled to the piston valve, normally closed, explosion proof (left to the discretion of the laboratory), and watertight, 12.7mm (1/2 in.), 2-way, stainless steel NPT fitting.

(5) Use only one type of Burkert piston and solenoid valve on a test stand.

6.6.5.4 Use control valve (TCV-144 in Fig. A2.6). The specified valve is a Badger Meter Inc. Model No. 1002TBN36SVOSALN36, 3-way globe (divert), 12.7mm (1/2-in.), air to open valve (see X1.17).

6.6.5.5 Use a heat exchanger (HX-6 in Fig. A2.6) for oil cooling. The specified heat exchanger is an ITT model 310-20 or an ITT Bell & Gossett, model BP-25-20 (Part No. 5-686-04-020-001), brazed plate (see X1.18).

NOTE 3: The ITT Standard and ITT Bell and Gossett heat exchangers have been standardized under one model and part number. The new replacement is Model BP410-20, Part No. 5-686-04-020-002.

6.6.5.6 Use an electric heater (EH-5 in Figs. A2.6) for oil heating. The specified heater is a heating element inserted in the liquid Cerrobise inside a Labeco oil heater housing (see X1.19). Any 3000 W heater elements may be used within the Labeco housing. There are two recommended heating elements: (1) a three element with Incaloy sheath, Chromolox Part No. GIC-MTT-330XX, 230 V, single phase, and (2) Wiegand Industries/Chromolox, Emerson Electric Model MTS-230A, Part No. 156-019136-014, 240 V single phase.

(1) It is specified that a thermocouple be installed in the external oil heater so that the temperature can be monitored. Install this thermocouple into the top of the heater into the Cerrobise (see Fig. A2.7) to an insertion depth of 244.48 ± 3.18 mm (9.625 ± 0.125 in.). Do not exceed the maximum temperature of 205°C (401°F).

(2) The procedure for replacing a heating element is detailed in Annex A3.



6.6.5.7 Install two oil filters (FIL-1 and FIL-2 in Figs. A2.6) in the external oil system. The filters specified are OHT6A-012-3 with a 28- μ m stainless steel screen, Part No.-OHT6A-013-2 (see X1.20). (34) Locate one filter anywhere in the external oil system after the oil circulation pump, and locate the other between the engine oil pump and where the oil enters the engine oil gallery.

6.6.5.8 Adhere to the nominal piping I.D. sizing shown in Fig. A2.6.

6.6.5.9 Use modified oil filter adapter assembly, Part No. OHT6D-003-1 (see X1.21), as shown in Fig. A2.6.

6.6.5.10 Engine oil plumbing shall be stainless steel tubing or piping or flexible hose suitable for use with oils at the temperatures specified. When using a flexible hose in the external oil system, excluding the line to the dump tank, use either Aeroquip No. 8 (Part No. 2807-8) or Aeroquip No. 10 (Part No. 2807-10) (see X1.22).

6.6.5.11 Insulation of plumbing for the external oil circulation system is mandatory. Insulation material selection is optional.

6.6.5.12 *Engine Oil Pan*—Use oil pan OHT-6D-001-1. A sight glass is provided for monitoring the oil level and determining oil consumption. See Annex A9 for instructions on oil consumption measurement/calibration.

6.7 *Fuel System*—A typical fuel delivery system incorporating all of the required features is shown in Fig. A2.11. The fuel system shall include provisions for measuring and controlling fuel temperature and pressure into the fuel flow measuring equipment and into the engine fuel rail.

6.7.1 There shall be a minimum of 10 cm (3.9 in.) of flexible line at the inlet and outlet of the fuel flowmeter (rubber/synthetic suitable for use with gasoline). Compression fittings are allowed for connecting the flexible lines to the fuel flowmeter. Fuel supply lines from the fuel flow measurement equipment to the engine fuel rail shall be stainless steel tubing or piping or any flexible hose suitable for use with gasoline.

6.7.2 *Fuel Flow Measurement*—Measure the critical fuel flow rate throughout the test. Use a Micro Motion Model CMF010 mass flow meter with either a RFT9739, 2700MVD or 1700MVD transmitter, see X1.24. The Micro Motion sensor may be mounted in a vertical or a horizontal position.

6.7.2.1 Coordinate fuel flow measurement to allow a meaningful calculation of brake specific fuel consumption in kg/kW-h (lb/hp-h). Recommend the use of frequency output from the fuel flowmeter to avoid electrical noise affecting analog signal output.

6.7.3 *Fuel Temperature and Pressure Control to the Fuel Flow Meter*—Maintain fuel temperature and pressure to the fuel flowmeter at the values specified in Tables 2–4. Precise fuel pressure control without fluctuation or aeration is mandatory for test precision. The fuel pressure regulator shall have a safety pressure relief, or a pressure relief valve, parallel to pressure regulator for safety purposes.



6.7.4 *Fuel Temperature and Pressure Control to Engine Fuel Rail*—Maintain fuel temperature and pressure to the engine fuel rail at the values specified in Tables 2–4. Precise fuel temperature and precise fuel pressure control without fluctuation or aeration is mandatory for test precision.

6.7.5 *Fuel Supply Pumps*—The method of providing fuel to the fuel flowmeter and engine is at the laboratory’s discretion as long as the requirements for fuel pressure and temperature are met. The average fuel pressure is 405 kPa (58.7 psig) for this engine.

6.7.6 *Fuel Filtering*—Filter the fuel supplied to the test stand in order to minimize fuel injector difficulties.

6.8 *Engine Intake Air Supply*—Use suitable apparatus to deliver approximately 4.0 m³/min (140 ft³/min) of air to the engine intake air filter. The intake air supply system shall be capable of controlling moisture content, dry bulb temperature, and inlet air pressure as specified in Tables 3 and 4, which is 11.4 ± 0.8 g/kg of dry air (79.8 ± 5.6 grains/lb of dry air), 27 ± 2°C (80.8 ± 3.6°F), and 0.05 ± 0.02 kPa (0.2 ± 0.1 in. H₂O). The specified engine intake air system components are considered part of the laboratory intake air system..

6.8.1 *Intake Air Humidity*—Measure humidity with the laboratory’s primary humidity system. Correct each reading for non-standard barometric conditions, using the following equation:

$$\text{Humidity (corrected), grains/lb} = 4354 \times \left(\frac{P_{\text{sat}}}{(P_{\text{bar}} - P_{\text{sat}})} \right) \quad (1)$$

where:

P_{sat} = saturation pressure, in. Hg, and
 P_{bar} = barometric pressure, in. Hg.

SI Units (Modernized Metric System):

$$\text{Humidity (corrected), g/Kg} = 621.98 \times \left(\frac{P_{\text{sat}}}{(P_{\text{bar}} - P_{\text{sat}})} \right) \quad (2)$$

where:

P_{sat} = saturation pressure, mm Hg, and
 P_{bar} = barometric pressure, mm Hg.

6.8.2 *Intake Air Filtration*—The air supply system shall provide either water-washed or filtered air to the duct. Any filtration apparatus utilized shall have sufficient flow capacity to permit control of the air pressure at the engine.



6.8.3 *Intake Air Pressure Relief*—The intake air system shall have a pressure relief device located upstream of the engine intake air filter snorkel. The design of the relief device is not specified.

6.9 *Temperature Measurement*—The test requires the accurate measurement of oil, coolant, and fuel temperatures, and care must be taken to ensure temperature measurement accuracy.

6.9.1 Check all temperature devices for accuracy at the temperature levels at which they are to be used. This is particularly true of the thermocouples used in the oil gallery, the coolant in, the inlet air, and the fuel to fuel rail. Iron-Constantine (Type J) thermocouples are recommended for temperature measurement, but either Type J or Type K (Chromel-Alumel) thermocouples may be used.

6.9.2 All thermocouples (excluding the oil heater thermocouple) shall be premium grade, sheathed types with premium wire. Use thermocouples of 3.2 mm (1/8 in.) diameter. Thermocouple lengths are not specified, but in all cases shall be long enough to allow thermocouple tip insertion to be in mid-stream of the medium being measured. The thermocouples shall not have greater than 5 cm (2 in.) of thermocouple sheath exposed to laboratory ambient.

6.9.3 Some sources of thermocouples that have been found suitable for this application are: Leeds and Northrup, Conax, Omega, Revere, and Thermo Sensor, see X1.14. Match thermocouples, wires, and extension wires to perform in accordance with the special limits of error as defined by ANSI in publication MC96.1-1975.

6.9.4 System quality shall be adequate to permit calibration to $\pm 0.56^{\circ}\text{C}$ (1°F) for individual thermocouples.

6.9.5 *Thermocouple Location*—All thermocouple tips shall be located in the center of the stream of the medium being measured unless otherwise specified.

6.9.5.1 *Oil Inlet (Gallery)*—Insert the thermocouple into the modified oil filter adapter plate so that the thermocouple tip is flush with the face of the adapter and located in the center of the stream of flow.

6.9.5.2 *Oil Circulation*—Locate the oil circulation thermocouple in the tee in the front of the oil pan where the oil from the external heat/cool circuit returns oil to the pan. The tip of the thermocouple shall be at the junction of the side opening in the tee with respect to the through passage in the tee.

6.9.5.3 *Engine Coolant In*—Locate the thermocouple tip in the center of the stream of flow and within 15 cm (5.9 in.) of the outside of the OHT6D-05-1 water pump adapter inlet.

6.9.5.4 *Engine Coolant Out*—Locate the thermocouple tip in the center of the stream of flow and in the coolant return neck within 8 cm (3.15 in.) of the housing outlet.

6.9.5.5 *Intake Air*—Locate the thermocouple in the GM plastic elbow in front of the throttle body as shown in Fig. A2.12.

6.9.5.6 *Fuel to Fuel Flowmeter*—Locate the thermocouple within 10 to 50 cm (3.9 to 19.7 in.) line length upstream of the fuel flow meter inlet.



6.9.5.7 *Fuel to Engine Fuel Rail*—Insert the thermocouple into the center of a tee or cross fitting and locate it 500 ± 50 mm (19.7 ± 1.97 in.) from the center point of the fuel rail inlet.

6.9.5.8 *Load Cell*—Locate the thermocouple within the load cell enclosure.

6.10 *AFR Determination*—Determine engine air-fuel ratio (*AFR*) by an *AFR* analyzer. Analysis equipment shall be capable of near continuous operation for 30-min periods.

6.10.1 The *AFR* analyzer shall meet the following specifications:

Measurement Range	AFR: 10.00 to 30.00 with H/C = 1.85, O/C = 0.00
Accuracy	± 0.1 AFR when 14.7 AFR With H/C = 1.85, O/C = 0.000

Temperature of exhaust gas used by sensor: -7 to 900°C (19.4 to 1652°F). A Horiba model MEXA 700 analyzer has been found suitable for this application (see X1.25).

6.10.2 The specified location of the analyzer sensing element in the exhaust system is shown in Fig. A2.13.

6.11 *Exhaust and Exhaust Back Pressure Systems:*

6.11.1 *Exhaust Manifolds*—Use production cast iron exhaust manifolds, GM Part # 12571102 Left and 12571101 Right, heat shields, GM part numbers 12580707 and 12580706, and OHT left #OHT6D-010-1 and right #OHT6D-009-1 take down tube assemblies. Take down tubes may need to be shortened to facilitate installation at the laboratory. O₂ sensors, OHT Part # OHT6D-047-1, will mount in the second hole downstream on the take down tubes. Plug unused holes. Take down tubes are shown in Fig. A2.14 and A2.15.

6.11.2 *Laboratory Exhaust System*—The exhaust system specified is shown in Fig. A2.13. Components can be clocked, trimmed or modified as needed to ease installation, but install all components in the order shown. The laboratory has the discretion to design the system downstream differently than the location shown in Fig. A2.12.

6.11.3 *Exhaust Back Pressure*—The exhaust system shall have the capability for controlling exhaust back pressure to the pressures specified in Tables 2–4. The specified exhaust back pressure probe is shown in Fig. A2.16, and the specified exhaust back pressure probe location in the exhaust system is shown in Fig. A2.13.

6.12 *Pressure Measurement and Pressure Sensor Locations*—Pressure measurement systems for this test method are specified in general terms of overall accuracy and resolution with explicit pressure tap locations specified.



6.12.1 Incorporate condensation traps when connecting tubing between the pressure tap locations and the final pressure sensors as directed by good engineering judgment. This precaution is particularly important when low air pressures (as in this test method) are transmitted by way of lines that pass through low-lying trenches between the test stand and the instrument console.

6.12.2 *Engine Oil*—Locate the pressure tap for the engine oil pressure at the oil filter adapter. Accuracy of 1 % with 6.9 kPa (1 psi) resolution is required.

6.12.3 *Fuel to Fuel Flowmeter*—Locate the pressure tap within 5 m (16.4 ft) from the fuel inlet of the fuel flow meter. Accuracy of 3.5 kPa (0.5 psi) is required.

6.12.4 *Fuel to Engine Fuel Rail*—Locate the pressure tap 235 ± 30 mm (9.25 ± 1.18 in.) from the center point of the fuel rail inlet. Accuracy of 3.5 kPa (0.5 psi) is required.

6.12.5 *Exhaust Back Pressure*—Locate the exhaust back pressure probe as shown in Fig. A2.13. The sensor shall be accurate to within 2 % of full scale with resolution of 25 Pa (0.1 in. H₂O).

6.12.6 *Intake Air*—Measure the intake air pressure at the location shown in Fig. A2.16. Sensor/readout accuracy required is 2 % of full scale with resolution of 5.0 Pa (0.02 in. H₂O).

6.12.7 *Intake Manifold Vacuum/Absolute Pressure*—Measure the intake manifold vacuum/absolute pressure at the throttle body adapter. Use a sensor having accuracy within 1 % of full scale and with 0.68 kPa (0.1 in. Hg)-resolution.

6.12.8 *Coolant Flow Differential Pressure*—See 6.5.9.

6.12.9 *Crankcase Pressure*—Locate the crankcase pressure tap as detailed in Annex A11.

6.13 *Engine Hardware and Related Apparatus*—This section describes engine-related apparatus requiring special purchase, assembly, fabrication, or modification. Part numbers not otherwise identified are GM service part numbers.

6.13.1 *Test Engine Configuration*—The test engine is a 2008 GM 3.6 L (LY7), OHT6D-099-1, V-6 engine equipped with fuel injection. Purchase the engine as a test ready unit (for procurement, see X1.3).

6.13.2 *PCM (Power Control Module)*—Use a special modified PCM Part No. OHT6D-012-4 engine power control module, see X1.26. This module controls ignition and fuel supply functions.

6.13.3 *Thermostat Block-off Plate*—Use an adapter plate OHT6D-004-1 as shown in Fig. A2.5 in place of the thermostat

6.13.4 *Wiring Harnesses*—Use a Dyno harness part # OHT6D-011-2, also include with the harness is an Engine Dyno Throttle Control OHT3H-011-1. Purchase from CPD (OH Technologies), see X1.28.

6.13.5 *Oil Pan*—Use oil pan, Part No. OHT6D-001-1, see X1.23.



6.13.6 *Engine Water Pump Adapter*— Purchase from the CPD, OHT6D-005-1, see X1.12.

6.13.7 *Thermostat Block-Off-Plate*— Purchase from the CPD, OHT6D-004-1.

6.13.8 *Oil Filter Adapter Plate*— Purchase from the CPD, OHT6D-003-1.

6.13.9 *Modified Throttle Body Assembly*--Purchase from the CPD, OHT6D-050-1.

6.13.10 *Fuel Rail*— Purchase from the GM Parts Dealer part# 12572886. Modify the fuel rail inlet connections for connection to the laboratory fuel supply system.

6.14 *Miscellaneous Apparatus Related to Engine Operation:*

6.14.1 *Special Tools* Purchase from the CPD

6.14.1.1 Flywheel Torque Tool, Purchase from the CPD, OHT3H-002-1 shown in Fig. A2.18.

6.14.1.2 Balancer Torque Tool, Purchase from the CPD, OHT3H-003-1 shown in Fig. A2.19.

6.14.2 *Additional Sensors and Other Hardware CPD*

6.14.2.1 Mass Airflow Sensor, Purchase from the CPD, OHT6D-040-1

6.14.2.2 Fuel Injectors, Purchase from the CPD, OHT6D-042-1

6.14.2.3 Spark Plug, Purchase from the CPD, OHT6D-043-1

6.14.2.4 Crank Position Sensor, Purchase from the CPD, OHT6D-044-1

6.14.2.5 Cam Position Sensor, Purchase from the CPD, OHT6D-045-1

6.14.2.6 Knock Sensor, Purchase from the CPD, OHT6D-046-1

6.14.2.7 Coolant Temperature Sensor, Purchase from the CPD, OHT6D-048-1

7. Reagents and Materials

7.1 *Engine Oil:*

7.1.1 Use VID BL (see X1.2) for new engine break-in and as primary calibration oil for evaluation of test oils. It is an SAE 20W-30 grade. Approximately 50 L (13.2 gal) of BL oil are required for each test.



7.1.2 Use VID BL Flush Oil (FO) (see X1.2) is special flushing oil (BL oil with increased solubility) that when changing oil after a test oil has been in the engine. Use approximately 11 L (2.9 gal) of FO for each test.

7.2 *Test Fuel*—Use only Haltermann (see X1.33) HF 003 fuel. Specification for HF 003 fuel is contained in Table 1. (**Warning**—Danger! Extremely flammable. Vapors harmful if inhaled. Vapors may cause flash fire (see A5)).

7.2.1 Make certain that all tanks used for storage are clean before they are filled with test fuel.

7.2.2 *Fuel Batch Usage/Documentation*—A complete test sequence shall be run on a single batch of test fuel. If a new batch of test fuel is introduced to the laboratory fuel supply system, it shall be done between finite tests. Document the fuel batch designation in the test report. In cases where the run tank contains more than one fuel batch, document the most recent fuel batch in the report.

7.3 *Engine Coolant*—The engine coolant shall be 100 % GM Dex-Cool.

7.4 *Cleaning Materials:*

7.4.1 *Organic Solvent Penmul L460*—See X1.29. (**Warning**—Harmful vapor. Store at moderate temperature (see A5)).

7.4.2 *Solvent*—Use only mineral spirits meeting the requirements of Specification D 235, Type II, Class C for Aromatic Content (0-2% vol), Flash Point (142°F/61°C, min) and Color (not darker than +25 on Saybolt Scale or 25 on Pt-Co Scale). (Combustible Health hazard.) Obtain a Certificate of Analysis for each batch of solvent from the supplier, see X1.30.

8. Preparation of Apparatus

8.1 This section assumes that the engine test stand facilities and hardware as described in Section 6 are in place. Emphasis is on the recurring preparations needed in the routine conduct of the test.

8.2 *Test Stand Preparation:*

8.2.1 *Instrumentation Preparation*—Perform the calibration of the temperature measuring system, the dynamometer load measuring system, the fuel flow measuring system, and the pressure measuring system (see 10.2 for additional details concerning instrumentation calibration) in a manner consistent with good laboratory practices and record it for future reference.

8.2.2 *External Oil System Cleaning*—Clean the entire external oil system using cleaning solvent (see 7.4.2) each time a newly built engine is installed.

8.2.3 *Exhaust Back Pressure Probe Renewal*—The exhaust back pressure probe can be used until it becomes cracked, brittle, or deformed. Clean the outer surface of the probe and clear all port holes. Check the probe for possible internal obstruction and reinstall the probe in the exhaust pipe. Stainless steel probes are generally serviceable for several tests; mild steel probes tend to become brittle after fewer tests.



8.2.4 *AFR Sensor Renewal*—Inspect AFR sensor (see 10.2 for AFR system calibration requirements).

8.2.5 *Hose Replacement*—Inspect all hoses and replace any that are deteriorated. Check for internal wall separations, which would cause flow restriction.

9. Engine Preparation

9.1 Purchase the engine OHT6D-099-1 as a test ready unit, purchase from CPD,

9.2 Stand set up kit, which contains engine mounts and other reusable parts, can be purchased from CPD, OHT6D-100-S1

9.3 *Cleaning of Engine Parts:*

9.3.1 *Cleaning*—Soak any parts to be cleaned in degreasing solvent until clean.

9.3.2 *Rinsing*—Wash the parts thoroughly with hot water.

9.4 *Engine Assembly Procedure:*

9.4.1 *General Assembly Instructions* - Assemble the external engine dress components according to the detailed description in the 2008 VID Assembly Manual, a copy of which can be obtained from the ASTM Test Monitoring Center (TMC, see A1) website. In cases of disparity, the explicit instructions contained in this test method take precedence over the assembly manual.

9.4.2 *Bolt Torque Specifications*—When installing the engine components, use a calibrated torque wrench to obtain the values specified. Specifications are shown in the 2008 VID Assembly Manual.

9.4.3 *Sealing Compounds*—Sealing compounds are as specified in the VID Engine Assembly Manual. Do not use sealers in tape form (loose shreds of tape can circulate in the engine oil and plug critical orifices).

9.4.4 New parts required for each new engine (see X1.3) are listed in Annex A4.

9.4.5 *Harmonic Balancer*—The balancer Part No. GM 12603180 is included on the engine by the engine supplier.

9.4.6 *Thermostat*—Remove the thermostat and replace with special plate OHT6D-004-1.

9.4.7 *Coolant Inlet*—Install water pump plate OHT6D-005-1, see X1.28.

9.4.8 *Oil Filter Adapter*—Install oil filter adapter is Part No.-OHT6D-003-1.

9.4.9 *Dipstick Tube*—Dipstick tube, Part No. GM 12612349 is included on the engine by the engine supplier.

9.4.10 *Sensors, Switches, Valves, and Positioner's:*



9.4.10.1 *Camshaft Position Sensors (2 ea.) (CMP)*—Camshaft position sensors, OHT6D-045-1 (2) are included on the engine by the engine supplier.

9.4.10.2 *Crankshaft Position Sensor (CKP)*—Crankshaft position sensor, OHT6D-044-1 is included on the engine by the engine supplier.

9.4.10.3 *Engine Coolant Temperature Sensor (ECT)*—Install engine coolant temperature sensor, Part No. GM 12566778 or OHT6D-048-1

9.4.10.4 *Heated Exhaust Gas Oxygen Sensors (HEGO)*—Use heated exhaust gas oxygen sensors, Part No. GM 12594935 or OHT6D-047-1. Ensure the HEGO's are correctly connected.

9.4.10.5 *PCV*—Remove the PCV valve and install OHT6D-013-1, vent all PCV points of connection to the crankcase pressure control system as detailed in Annex A11 and Fig. A2.17 (see 6.12.9). Plug all associated vacuum lines.

9.4.10.6 *Mass Air Flow Sensor*—Use mass air flow sensor, Part # OHT6D-023-1

9.4.11 *Ignition System:*

9.4.11.1 *Ignition Coils*—GM 12618542 is included on the engine by the engine supplier.

9.4.11.2 *Spark Plugs*—Use spark plugs, OHT6D-043-1

9.4.12 *Fuel Injection System:*

9.4.12.1 *Fuel Injectors*—Use fuel injectors, OHT6D-042-1. Refer to Annex A10 for injector flow specifications. Verification of each injector is required prior to use.

9.4.12.2 *Fuel Rail*—Install modified fuel rail, Part No GM 12572886 as modified in 6.12.4

9.4.12.3 *Fuel Pressure Regulator*—Install a fuel pressure regulator. Paxton Model # 8F002-004 has been found to be suitable for this application. (See X1.35)

9.4.13 *Intake Air System*—The engine intake air system components may be oriented according to laboratory requirement. However, use all of the specified components.

9.4.13.1 *Air Cleaner Housing (Air Box)*—Use GM 15147455 housing, and 19151528 lower cover. Use clamps 15147463 and 15147462 along with screws 11588831 and bolt 25314060 as needed.

9.4.13.2 *Crankcase Ventilation Tube*—Plug crankcase ventilation tube on duct, GM 25733251.

9.4.13.3 *Air Cleaner Modification*

y—Modify the GM elbow #25733251 for the thermocouple and pressure taps (see Fig. A2.16).



9.4.13.4 *Air Cleaner Element*—Use air cleaner element, GM 25735595.

9.4.13.5 *Throttle Body*—Use two throttle bodies. OHT6D-050-1 with modified throttle linkage will be installed on the engine. A second throttle body will be connected to the wiring harness and mounted at the stand.

9.4.13.6 *Throttle Body Air Duct*—Use throttle body air duct, GM 25733251.

9.4.14 *Engine Management System*: GM PCM E77 with Revision 3 software, part number OHT6D-012-4.

9.4.14.1 *Engine Wiring Harness*—Use a special engine/dyno wiring harness, Part No. OHT6D-011-2, purchase this part from the CPD (see X1.34).

9.4.14.2 *Power Control Module*—Use PCM engine control module, Part No. OHT6D-012-4, purchase this part from the CPD (see X1.34). This module controls ignition and fuel supply functions.

(1) Supply the PCM power from a battery and/or a regulated power supply (12 V to red wire). Ground the PCU/PCM ground wire to the engine. When using a battery, run a 2-gage wire back to the battery negative to prevent interruption/interference of the PCM operation.

9.4.15 *Accessory Drive Units*—Do not use external drive units, including alternators, fuel pumps, power steering units, air pumps, air conditioning compressors, and so forth.

9.4.16 *Exhaust Manifolds*—Use exhaust manifolds, right hand GM # 12571102 and left hand GM # 12571101 and heat shields GM # 12580707 and GM # 12580706. Torque Bolts in the sequence shown in the 2008 VID Assembly Manual.,

9.4.17 *Engine Flywheel and Guards*— Use flywheel OHT6D-020-1. Purchase this part from the CPD, install an engine flywheel guard and safety housing to suit test stand requirements.

9.4.18 *Lifting of Assembled Engines*—Assembled engines shall not be lifted by the intake manifold since this is known to cause engine coolant leaks. Refer to 2008 VID Assembly Manual for proper lifting instructions and lift locations.

9.4.19 *Engine Mounts*— Engine mounts use OHT3H-026-1 front and OHT3H-025-1 rear, see X1.35.

10. Calibration

10.1 *Stand/Engine Calibration*— To ensure proper response to various oil parameters, conduct a reference oil test when a new or previously used test engine is installed in a test stand. This event will be monitored by the ASTM TMC. See 11.1.2 prior to attempting calibration of a new stand. The TMC will assign reference oils for calibration tests. The reference oils used to calibrate Sequence VID engine test stand/engine combinations have been formulated or selected to represent specific chemical types or performance levels or both. These oils are normally supplied under code numbers (blind reference oils) to ensure that the testing laboratory is not influenced by preconceived opinions in assessing test



results. Number each Sequence VID test to identify the stand number, the number of runs on that stand, the engine number, and the number of runs on the engine. For example, 56-21-3-8 defines a test on stand 56, which is test 21 on stand 56, engine number 3, and the 8th test on engine number 3. For reruns of operationally invalid or unacceptable reference oil the stand run number shall be incremented by one and the engine run number shall be followed by the letter A for the first re-run, B for the second re-run, and so forth. For example, the next test number for an operationally invalid or unacceptable test would be 56-22-3-8A.

10.1.1 *Procedure*—Test stand/engine calibration is accomplished by conducting tests on ASTM TMC reference oils (see X1.2).

10.1.1.1 Conduct reference oil tests on each test stand/engine combination within a laboratory according to ASTM TMC Lubricant Test Monitoring System (LTMS) guidelines. *Do not terminate a reference test due to an FEI result.*

10.1.1.2 For a given test stand/engine combination, following the first calibration period of a new stand/engine combination, conduct a minimum of one operationally valid, statistically acceptable reference oil test after four full-length non-reference oil tests or 700 engine hours or 120 days, whichever occurs first.

10.1.1.3 Thereafter conduct a minimum of one operationally valid, statistically acceptable reference oil test after **XX** full-length non-reference oil tests or **XX** engine hours, or **XX** days, whichever occurs first. The **XX** elapsed days are judged from the end-of-test (EOT) day of the last operationally valid, statistically acceptable reference oil test to the start-of-test (SOT) day of a calibrated non-reference oil test.

10.1.1.4 If more than 120 days elapse between Sequence VID tests, EOT to SOT, on a stand/engine combination, a minimum of one operationally valid, statistically acceptable (according to LTMS) test is required. If acceptable results are obtained on the reference oil the test stand/engine is calibrated.

10.1.1.5 Re-reference the engines once removed from the test stand and re-installed, even if the test number and time criteria are met by the engine. Laboratories shall inform the TMC with a written explanation when a test engine is removed from a test stand and installed into another test stand. Only appropriate Sequence VID test engines (see X1.3) may be referenced.

10.1.1.6 The effective date of a reference test is the LTMS date and time of the reference test. Test start time is defined as the introduction of the reference oil into the engine, but the total test length shall include the BLB runs also. The LTMS date and time are defined as the date and time the test was completed (completion of the BL run following the reference oil) unless a different date and time are assigned by the TMC. The TMC may schedule more frequent reference oil tests (or approve less frequent reference oil tests) at its discretion. Under special circumstances (that is, extended downtime due to industry-wide parts or fuel outages) the TMC may extend reference periods. Note non-reference oil tests conducted during the extended time allowance in the test note section of the report.



10.1.1.7 Failure of a reference oil test to meet Shewhart or Exponentially Weighted Moving Average (EWMA) control chart limits can be indicative of a false alarm, engine, test stand, or industry-related problem. When this occurs, the laboratory, in conjunction with the TMC, shall attempt to determine the problem source. The ASTM Sequence VI Surveillance Panel adjudicates industry problems. The TMC will decide, with input as needed from industry expertise (testing laboratories, test procedure developer, ASTM Technical Guidance Committee, Surveillance Panel, and so forth), if the reason for any unacceptable blind reference oil test is isolated to one particular engine or stand or related to other stands. If it is decided that the problem is isolated to an individual engine or stand, calibrated testing on other stands may continue throughout the laboratory. The laboratory may elect to attempt additional reference oil tests in the same engine. In the event the engine does not attain calibration, the laboratory shall remove the engine and go through the normal process of calibrating a new engine. Operationally valid, statistically unacceptable data on removed engines will be included in all appropriate databases (industry reference oil severity and precision) unless the engine failing to calibrate is a new engine (has never been calibrated and conducted non-reference oil tests).

10.1.1.8 If non-standard tests are conducted on a calibrated engine or test stand, recalibrate the stand and engine prior to running standard tests.

10.1.2 *Reporting of Reference Results*—Transmit the reference oil test results to the TMC (see Annex A1) using the appropriate forms as shown in Annex A7 immediately after completion of test. The TMC will review the transmitted reference oil test results and use the LTMS to determine test acceptability. The complete final test report package as defined in Annex A7 shall be received within 30 days of test completion by the following party:

Manager of Operations
ASTM TMC
6555 Penn Avenue
Pittsburgh, PA 15206-4489

10.1.3 *Analysis of Reference/Calibration Oils:*

10.1.3.1 *Reference Oils Identification*—Do not subject reference oils to either physical or chemical analyses for identification purposes. Identifying the oils by analyses could undermine the confidentiality required to operate an effective blind reference system. Therefore, reference oils are supplied with the explicit understanding that they will not be subjected to analyses other than those specified within this procedure unless specifically authorized by the TMC. In such instances, supply written confirmation of the circumstances involved, the data to be obtained, and the name of the person requesting the analysis to the TMC.

10.1.3.2 *BL Baseline Calibration Oil and BL-FO Flush Oil*—The Baseline Calibration (BL) Oil and BL-FO Flush Oil may be analyzed only to the extent required to evaluate the effectiveness of a test stand's flushing system. This analysis will be limited to molybdenum content. Do not subject the BL oil or BL-FO oil to further physical or chemical analyses other



than those specified within this procedure unless specifically authorized by the TMC. In such instances, supply written confirmation of the circumstances involved, the data to be obtained, and the name of the person requesting the analysis to the TMC.

10.2 Instrument Calibration—Record all instrument calibrations for future reference. Perform a complete test stand instrument calibration every six months. The following are to be calibrated prior to a reference oil test sequence. A previously calibrated (existing) stand/engine will require that the following be calibrated prior to the next reference test: (1) fuel flowmeter; (2) engine speed; (3) AFR analysis equipment; and (4) exhaust back-pressure equipment.

10.2.1 Engine Load Measurement System—Use deadweights to calibrate at the start of a test and before each reference oil test. Prior to calibration, start the engine and run for a minimum of 30 min at 1500 ± 5 r/min, 70 ± 2 N·m. Shut the engine down, leave dynamometer cooling water on, and start performing the load cell calibration within 3 min after shutdown.

10.2.1.1 Perform the calibration at the 3 designated torques (approximately 26, 37, and 107 N·m). The stand load measurement system shall perform within ± 0.3 N·m of the calibration standard.

10.2.2 Fuel Flow Measurement System—Use accurate mass scale measurements for calibrating. Perform this calibration at three fuel flow rates (approximately 1.0, 4.0, and 7.5 kg/h). Evaluate each flow rate a minimum of three times to verify repeatability. Adjust the results to compensate for evaporation.

10.2.2.1 The test stand flowmeter shall perform to within 0.25 % at 7.5 kg/h, 0.32 % at 4.0 kg/h, and 0.54 % at 1.0 kg/h of the calibration standard. For each flow rate, a minimum of three consecutive flow readings shall be within the specified tolerance. The calibration standard shall be at least 4 times more accurate than the test stand flowmeter at each specified flow rate.

10.2.3 Coolant Flow Measurement System—Calibrate the flow measuring device a minimum of once every six months.

10.2.4 Thermocouple and Temperature Measurement System—Check the calibration of the test stand temperature measurement system (thermocouple through readout) at the test stand using the existing readout system a minimum of once every six months. For the critical temperatures (see Table 3) the individual temperature sensors shall indicate within $\pm 0.56^\circ\text{C}$ ($\pm 1^\circ\text{F}$) of the laboratory calibration standards. The calibration equipment utilized shall be appropriate for the desired $\pm 0.56^\circ\text{C}$ ($\pm 1^\circ\text{F}$) accuracy level. See 6.9 for additional thermocouple calibration requirements.

10.2.5 Humidity Measurement System—Calibrate the primary laboratory measurement system at each stand a minimum of once every six months using a hygrometer with a minimum dew point accuracy of $\pm 0.55^\circ\text{C}$ at 16°C ($\pm 1^\circ\text{F}$ at 60°F). Locate the sample tap on the air supply line to the engine in the intake air cleaner.

10.2.5.1 The calibration consists of a series of paired humidity measurements comparing the laboratory system with the calibration hygrometer. The comparison period lasts from 20 min to 2 h with



measurements taken at 1 to 6-min intervals, for a total of twenty paired measurements. The measurement interval shall be appropriate for the time constant of the humidity measuring instruments.

10.2.5.2 Verify that the flow rate is within the equipment manufacturer's specification, and that the sample lines are non-hygroscopic. Correct dew point hygrometer measurements to standard conditions (101.12 kPa [29.92 in. Hg]) using the appropriate equation (see 6.8.1). Compute the difference between each pair of readings and calculate the mean and standard deviation of the twenty paired readings, using Eq. A8.1 and Eq. A8.2 in Annex A8. The absolute value of the mean difference shall not exceed 1.43 g/kg (10 grains/lb), and the standard deviation shall not be greater than 0.714 g/kg (5 grains/lb). If these conditions are not met, investigate the cause, make repairs, and recalibrate. Maintain calibration records for two years.

10.2.6 *Other Instrumentation*—As a minimum, calibrate instrumentation for measuring parameters other than those detailed in 10.2–10.2.5 every six months. Calibration of the oil heater instrumentation is not required.

11. Test Procedure

11.1 *External Oil System*—The external oil system shall be cleaned each time a new engine is installed (see 8.2.2). If this is a new test stand, demonstrate the flush effectiveness.

11.1.2 *Flush Effectiveness Demonstration*—A laboratory shall demonstrate the flush effectiveness of their flying flush oil system for any new stand and for any stand that has had modifications made to the oil system. By using an oil containing molybdenum with a 400 ppm minimum a laboratory shall demonstrate a 99 % flush effectiveness, by Inductive Coupled Plasma (ICP), after the final flush of a detergent flush (see 11.5.9.1(10)) when detergent flushing from the demonstration oil to BL oil. ASTM oil FEEO-103 (FEEO-103 available from TMC X1.1) has proven satisfactory for use in this demonstration. The procedure is as follows (FM = ASTM FEEO-103 (FM) or other suitable oil containing molybdenum):

11.1.2.1 With the engine already charged with BL oil, warm engine to Stage Flush (see Table 4).

11.1.2.2 Take a 118-mL (4-oz) sample of the FM oil from the oil reservoir (Sample New Oil).

11.1.2.3 Flush in FM oil, run 30 min.

11.1.2.4 Flush in FM oil, run 30 min.

11.1.2.5 Flush in FM oil (this completes the FM oil change).

11.1.2.6 Run 30 min, take a 118-mL (4-oz) purge sample and pour back into the engine. Take a 118-mL (4-oz) retain sample (Sample 1).

11.1.2.7 Flush to FO Flush oil, run 30 min.

11.1.2.8 Flush to FO Flush oil, run 2 h, take a 118-mL (4-oz) purge sample and pour back into the engine. Take a 118-mL (4-oz) retain sample (Sample 2).



11.1.2.9 Flush in BL oil, run 30 min, take a 118-mL (4-oz) purge sample, pour back into engine. Take a 118-mL (4-oz) retain sample (Sample 3).

11.1.2.10 Flush in BL oil, run 30 min, take a 118-mL (4-oz) purge sample and pour back into engine. Take a 118-mL (4-oz) retain sample (Sample 4).

11.1.2.11 Flush in BL oil, take a 118-mL (4-oz) purge sample and pour back into engine. Take a 118-mL (4-oz) retain sample (Sample 5).

11.1.2.12 *Analyze Samples*—Analyze new oil, 1, 2, 3, 4, and 5 (Comparison is Sample 11.1.2.11 versus 11.1.2.6) by ICP Test Method D5185 for the molybdenum and report the results to TMC.

11.1.3 *Preparation for Oil Charge*—Check the apparatus carefully to be sure that all oil lines and fittings are properly tightened and aligned. This includes the apparatus for the flying flush oil change system.

11.2 *Initial Engine Start-Up*—Connect the fuel line to the engine fuel rail or open the fuel shut-off valves, or both. Ready the control console (engine ignition on, external oil circulation pump on, safety circuits ready). Crank the engine. When the engine is running at idle (approximately 700 r/min, zero load), check for fuel, oil, coolant, water, and exhaust leaks.

11.3 *New Engine Break-In*—A broad overview of the new engine break-in is as follows:

11.3.1 A minimum of 150 h of cyclical operation with BL oil is required for engine break-in. Hourly BSFC measurements are routinely recorded. The intense care for precision required for test operation is not required for cyclical break-in operation.

11.3.2 *Oil Charge for Break-in*—Service both oil filters to ensure that they are clean. Drain oil and charge the engine with 5.4 L (5.71 qt) of fresh BL oil. Use this oil charge for the entire new engine break-in.

11.3.3 *Break-in Operating Conditions*— Follow the break-in schedule for new engines as shown in Table 2. It is suggested that the cycling be a step function, rather than a ramp function. If a ramp function is used, take care to ensure that the ramp is not too mild, since too mild a ramp may not work the engine hard enough to successfully accomplish break-in.

11.3.4 *Stand Requirements for Break-In*—The engine break-in shall be done on a test stand that has a Midwest or Eaton 37 kW (50 hp) Model 758 dry gap dynamometer (see X1.4) and meets the specifications shown in Table 2.

11.3.5 Ramp traces at `1, `75 and `149 h will be provided to the TMC for review prior to the assignment of the initial reference oil. When it is necessary to extend break-in beyond 150h, provide a ramp trace taken 1h before break-in is terminated. Record speed and load at a minimum of one second intervals.

11.4 *Routine Test Operation*—



11.4.1 *Start-Up and Shutdown Procedures*—In accomplishing a routine engine shutdown, disconnect the fuel lines or close the fuel valves for the fuel supply after the engine has been shut down.

11.4.1.2 *Unscheduled Shutdown and Restart*—There are no scheduled shutdown periods in the test. Continuous operation is expected from initial warm-up prior to flushing in the BL oil before test oil through the final testing of the BL oil segment after the test oil. If an unexpected shutdown does occur, the maximum allowable downtime per test is 12 h. Only four unscheduled shutdowns per test are allowed. **Further investigation is being undertaken to evaluate shutdown limits and their effect on stabilization and BSFC measurement runs.** Report all shutdowns and the amount of time per shut down in the downtime occurrence section of the final report. Report all other deviations in test time from Table 5 in the comment section of the final report. Include details in these comments as to why the deviation occurred and the total time of the occurrence. If unexpected shutdowns occur, the following guidelines apply:

Testing Phase	Restart and Continuation Procedure
During Stabilization Runs	Return to start of current stage
During BSFC Measurement Runs	Re-accomplish the stabilization in entirety and acquire all new BSFC data after the design stabilization.
During Oil Flushes or During Test Oil Aging	Continue on existing schedule without deleting any of the prescribed operating time.

11.4.2 *Flying Flush Oil Exchange Procedures*— These flushing procedures involve oil exchanges without stopping the engine. In all cases, bring the engine to Stage Flush conditions (see Table 4) before initiating any flush.

11.4.2.1 *Detergent Flush (FO), Test Oil to BL Oil*—This procedure is intended to remove any residual effects from the previous oil and is performed when flushing from test oil to BL oil. Accomplish this detergent flush in the following steps:

- (1) Heat the FO oil and BL oil external reservoirs within the range of 93 to 107°C (199.4 to 224.6°F).
- (2) Bring the engine to Stage Flush conditions (see Table 4).
- (3) Switch external oil system to Flush Mode and allow the engine to draw 5.4 L (5.71 qt) of FO Oil while 5.4 L (5.71 qt) of oil is being scavenged from the oil sump. Note that the scavenge pump will draw oil from the oil sump until the oil level in the dump tank reaches the 5.4 L (5.71 qt) level and the float level switch in the dump tank turns off the scavenge pump. When the scavenge pump is turned off, the solenoids switch so that oil starts circulating to the engine as the oil sump fills to 5.4 L (5.71 qt). When the oil level in the sump reaches the full level 5.4 L (5.71 qt), the float level switch in the oil pan closes the solenoid to the oil reservoir and the oil then fully circulates to the engine.



- (4) Allow the engine to continue running at Stage Flush conditions for 30 min.
- (5) Re-accomplish Step 3 with FO oil.
- (6) Allow the engine to continue running at Stage Flush conditions for 2 h.
- (7) With BL oil at the specified temperature for flushing, switch to the BL oil reservoir and accomplish Step 3 with BL (flush, fill, run).
- (8) Allow the engine to continue running at Stage Flush conditions for 30 min.
- (9) Re-accomplish Step 3 with BL oil.
- (10) Allow the engine to continue running at Stage Flush conditions for 30 min.
- (11) Re-accomplish Step 3 with BL oil.
- (12) After completing the flush and when Flush conditions are met, add or drain oil to achieve the engine full level.
- (13) Return the engine to Stage 1 (see Table 3), and follow stabilization procedure for BSFC measurement with BL oil.

11.4.9.2 *Double Flush From BL Oil to Test Oil*— This procedure removes the previous oil and is performed when flushing from BL oil to test oil. This double flush is accomplished as follows:

- (1) Heat the test oil in the external reservoir within the range of 93 to 107°C (199.4 to 224.6°F).
- (2) Bring the engine to Stage Flush conditions.
- (3) Switch the external oil system to Flush Mode and allow the engine to draw 5.4 L (5.71 qt) of non-reference oil while 5.4 L (5.71 qt) of oil is being scavenged from the oil sump. Note that the scavenge pump will draw oil until the level in the oil dump tank reaches the 5.4 L (5.71 qt) level and the float level switch in the dump tank turns off the scavenge pump. When the scavenge pump is turned off, the solenoids switch so that oil starts recirculation to the engine as the sump fills to 5.4 L (5.71 qt) (6.34 qt). When the oil level in the sump reaches the full level (5.4 L (5.71 qt)), the float level switch in the oil pan closes the solenoid to the oil reservoir, and the oil fully re-circulates to the engine.
- (4) Allow the engine to continue running at Stage Flush conditions for 30 min.
- (5) Re-accomplish Step 3.
- (6) Allow the engine to continue running at Stage Flush conditions for 30 min.
- (7) Re-accomplish Step 3.



(8) Bring the engine to Flush conditions.

(9) After completing the flush and when Flush conditions are met, add or drain oil to achieve the engine full level.

11.4.2.2 *Double Flush From BLA Oil (Baseline After) to BLB1 Oil (Baseline Before Set 1)*—This procedure removes the previous oil and is performed when flushing from BLA oil to BLB1 oil between oil tests. Accomplish this double flush as follows:

(1) Heat the BL oil in the external reservoir within the range of 93 to 107°C (199.4 to 224.6°F).

(2) Bring the engine to Stage Flush conditions.

(3) Switch the external oil system to Flush Mode and allow the engine to draw 5.4 L (5.71 qt) of BL oil while 5.4 L (5.71 qt) of BL oil is being scavenged from the oil sump. Note that the scavenge pump will draw oil until the level in the oil dump tank reaches the 5.4 L (5.71 qt) level and the float level switch in the dump tank turns off the scavenge pump. When the scavenge pump is turned off, the solenoids switch so that oil starts recirculation to the engine as the sump fills to 5.4 L (5.71 qt). When the oil level in the sump reaches the full level 5.4 L (5.71 qt), the float level switch in the oil pan closes the solenoid to the oil reservoir, and the oil fully re-circulates to the engine.

(4) Allow the engine to continue running at Stage Flush conditions for 30 min.

(5) Re-accomplish Step 3.

(6) Allow the engine to continue running at Stage Flush conditions for 30 min.

(7) Re-accomplish Step 3.

(8) Return the engine to Stage 1, and follow the stabilization procedure for BSFC measurement with BL oil.

11.4.2.4 *Double Flush From BLB1 Oil to BLB2 Oil*—This procedure removes the previous oil and is performed when flushing from BLB1 oil to BLB2 oil between oil tests. Accomplish this double flush as follows:

(1) Heat the BL oil in the external reservoir within the range of 93 to 107°C (199.4 to 224.6°F).

(2) Bring the engine to Stage Flush conditions.

(3) Switch the external oil system to Flush Mode and allow the engine to draw 5.4 L (5.71 qt) of BL oil while 5.4 L (5.71 qt) of BL oil is being scavenged from the oil sump. Note that the scavenge pump will draw oil until the level in the oil dump tank reaches the 5.4 L (5.71 qt) level and the float level switch in the dump tank turns off the scavenge pump. When the scavenge pump is turned off, the solenoids switch so that oil starts recirculation to the engine as the sump fills to 5.4 L (5.71 qt). When the oil level



in the sump reaches the full level 5.4 L (5.71 qt), the float level switch in the oil pan closes the solenoid to the oil reservoir, and the oil fully re-circulates to the engine.

(4) Allow the engine to continue running at Stage Flush conditions for 30 min.

(5) Re-accomplish Step 3.

(6) Allow the engine to continue running at Stage Flush conditions for 30 min.

(7) Re-accomplish Step 3.

(8) Return the engine to Stage 1, and follow the stabilization procedure for BSFC measurement with BL oil.

(9) Compare total fuel consumption between BLB1 and BLB2. The % delta between BLB1 and BLB2 shall fall within -0.20 to +0.40. If total fuel consumption % delta falls outside of these values, conduct BLB3 by repeating steps 1 through 9. If the % delta between BLB2 and BLB3 exceeds -0.20 to +0.40, investigate potential cause and restart test at BLB1.

11.4.3 *Test Operating Stages*—Table 3 depicts the test operating conditions for the stages, and Table 5 depicts the schedule of operation.

11.4.3.1 After an engine has been broken in and deemed an acceptable stand/engine combination by TMC, evaluate non-reference oils relative to BL oil. This entails comparing the weighted fuel consumed (mass) for aged (16 and 84 h) test oil run at the six stages with that of the fresh BL oil run before and after the test oil.

11.4.4 *Stabilization to Stage Conditions*—After the flying flush to each oil (BL or test oil) and for the change to each stage, a stabilization time of 1 h is specified prior to beginning the BSFC measurement cycle. This time is that which elapses between initially changing the speed/load/temperature set points and the beginning of the first BSFC measurement cycle for that stage. It, therefore, includes the time during which the temperatures are changing. Manage the speed, load, coolant, and oil temperature control loops such that the processes are brought to the desired set points.

11.4.5 *Stabilized BSFC Measurement Cycle*—After the stabilization period (1 h) has elapsed for each stage, use 1 sec data for each of six – 5-min segments. Each 5-min segment will use the average for speed, load and fuel flow from the 300 ± 10 samples to calculate the BSFC for each segment. These 300 samples are snapshot readings no averaging or filtering is allowed.

11.4.6 *BLB1 Oil Flush Procedure for BL Oil Before Test Oil Run 1*—At the start of test, warm the engine to Stage Flush conditions (see Table 4) and flush the BL oil into the engine without shutting the engine down. The sequences of events for this flush are as follows (see 11.5.9.2):

11.4.6.1 Warm engine to Stage Flush.

11.4.6.2 Double flush to BL oil.



11.4.6.3 Proceed with BL oil BSFC data acquisition.

11.4.7 *BSFC Measurement of BLB1 Oil Before Test Oil*— Run Stages 1 through 6 as detailed in Table 3. Obtain 6 BSFC measurements at each stage according to the Critical Data Acquisition Period as detailed in and 11.4.5.

11.4.8 *BLB2 Oil Flush Procedure for BL Oil Before Test Oil Run 2*—At the start of test, warm the engine to Stage Flush conditions (see Table 4) and flush the BL oil into the engine without shutting the engine down. The sequences of events for this flush are as follows (see 11.5.9.2):

11.4.8.1 Warm engine to Stage Flush.

11.4.8.2 Double flush to BL oil.

11.4.8.3 Proceed with BLB2 oil BSFC data acquisition.

11.4.9 *BSFC Measurement of BLB2 Oil Before Test Oil*— Run Stages 1 through 6 as detailed in Table 3. Obtain 6 BSFC measurements at each stage according to the Critical Data Acquisition Period as detailed in and 11.4.5.

11.4.10 *% Delta Calculation for BLB1 vs. BLB2* – Following the completion of BLB-2 calculate the Total Consumed (non-weighted) between these using the following formula:

$$\text{Total Fuel Consumed BLB1} - \text{Total Fuel Consumed BLB2} / \text{BLB1} = \% \quad (3)$$

11.4.10.1 Acceptable range for baseline between - BLB1 & BLB2 is -0.20% to +0.40%, if total fuel consumption % delta between BLB2 and BLB1 exceeds -0.20 to +0.40, a third BLB3 may be run repeat steps in 11.4.8 for this oil flush. If a third set is required the result from the original BLB1 & BLB2 shall be reported in the comments section of the test report.

11.4.10.2 If the calculated % delta between BLB2 and BLB3 exceeds -0.20 to +0.40, shutdown the test and investigate potential cause and restart test at BLB1.

11.4.11 *Test Oil Flush Procedure*—After the BL oil before test oil segment is completed, flush the test oil into the engine without shutting the engine down. The sequences of events for this flush are as follows (see 11.5.9.2):

11.4.11.1 Double flush to test oil.

11.4.11.2 Adjust test oil to full mark at stage flush conditions. No oil additions are allowed after the first hour of aging.

11.4.11.3 Proceed with test oil aging.

11.4.12 *Test Oil Aging, Phase I*—Run 16-h of aging at the conditions shown in Table 4. This 16-h interval starts when the double flush procedure is completed. The maximum allowable off-test-time



during Phase I Aging is 2 h. If off-test time exceeds 2 h, the test is invalid. At the completion of the Phase I aging, run the first of two fuel economy measurements on the test oil.

11.4.13 *BSFC Measurement of Aged (Phase I) Test Oil*— After Aging Phase I (16 h) has completed, run Stages 1 through 6 as detailed in Table 3. Obtain 6 BSFC measurements at each stage according to the Critical Data Acquisition Period as detailed 11.4.5.

11.4.14 *Test Oil Aging, Phase II*—Run 84-h of aging at the conditions shown in Table 4. The maximum allowable off-test-time during Phase II Aging is 2 h. If off-test time exceeds 2 h, the test is invalid. At the completion of the Phase II aging, run the second of two fuel economy measurements on the test oil.

11.4.15 *BSFC Measurement of Aged (Phase II) Test Oil*— After Aging Phase II (84 h) has completed, run Stages 1 through 6 as detailed in Table 3. Obtain 6 BSFC measurements at each stage according to the Critical Data Acquisition Period as detailed in 11.4.5.

11.4.15.1 *Oil Consumption During Aging*—Monitor test oil consumption during the 84 -h aging period by observing the running oil level in the engine oil sight glass. Final oil consumption is recorded at the completion of the second fuel economy measurement (Phase II) once the engine is stable in the Flush conditions.

11.4.16 *Oil Consumption and Sampling*— Once Phase II FEI Stage 6 is completed the test will go to Flush conditions; once it is stabilized the oil consumption shall be recorded prior to the first flush. The maximum allowable oil consumption for reference and non-reference oil tests is **TBD** mL. After recording the oil level, take a 120–mL (4–oz) sample from the outlet (top) of the oil heater for viscosity measurement (see 13.2.10).

11.4.17 *Flush Procedure for BL Oil (BLA) After Test Oil*—After the test oil segment of the test is completed, flush FO oil into the engine without shutting the engine down.

11.4.17.1 FO to BL oil.

11.4.17.2 Proceed with BL oil BSFC data acquisition.

11.4.17.3 *BSFC Measurement of BL Oil After Test Oil*—Run Stages 1 through 6 as detailed in Table 3. When the BLA Test Oil is completed, calculate the BL shift as follows:
Using unweighted, total fuel consumption data, BL shift after = $BLB2 - BLA / BLB2$

11.4.18 *General Test Data Logging Forms*—Forms used for recording data are left up to the laboratory's discretion.

11.4.19 *Diagnostic Review Procedures*—To ensure test operational validity, conduct a critical review of the data at frequent intervals during the test. The final review after the test is completed is only partially effective in identifying problems since the indicated data cannot be cross examined by first hand observation. Early detection of instrumentation errors is essential and often the record for information



parameters (dependent variables) indicate problem areas involving the primary control parameters. The following parameter response characteristics are significant:

- 11.4.19.1 Stabilization trends,
- 11.4.19.2 Air fuel ratio stability,
- 11.4.19.3 Fuel flow stability,
- 11.4.19.4 Intake manifold vacuum absolute pressure,
- 11.4.19.5 Speed,conduct
- 11.4.19.6 Load, and
- 11.4.19.7 Exhaust back pressure.
- 11.4.20 *Total Test Length*—Total test length is approximately 155 h.

12. Determination of Test Results

12.1 *FEI1 and FEI2 Calculations* :

12.1.1 Calculate the test results as detailed in Table 6.

UNTIL TEST DEVELOPMENT IS AT A POINT WHERE THESE CAN BE REVISED

13. Final Test Report

13.1 *Validity Statement*—Include a statement pertaining to the validity of the test at the bottom of the appropriate form, which is signed by the person responsible for conducting the test.

13.2 *Report Format*—For reference oil tests, the standardized report form set and data dictionary for reporting test results and for summarizing operational data are required. Report forms and Data Dictionary are available from the TMC. Complete the forms using the formats shown in the Data Dictionary. Use a header data dictionary, preceding the data when transmitting electronically. The latest version of the header data dictionary can be obtained from the TMC. Round data in accordance with Practice E29.

13.2.1 *BL Before 1 and 2 Start Dates*—The BL before 1 and 2 start dates are defined as the date when the BL before test oil(s) flush enters into the engine.

13.2.2 *BL Before Start Time*—The BL before start time(s) are defined as the time when the BL before test oil(s) flush enters into the engine.

13.2.3 *Test Oil Start Date*—This is defined as the date when the first non-reference or reference test oil flush enters into the engine.

13.2.4 *Test Oil Start Time*—This is defined as the time when the first non-reference or reference test oil flush enters into the engine.



13.2.5 *BL After Test Oil Start Date*—The BL after test oil start date is defined as the date when the FO test oil flush enters into the engine.

13.2.6 *BL After Test Oil Start Time*—The BL after test oil start time is defined as the time when the FO test oil flush enters into the engine.

13.2.7 *Total Engine Hours at End of Test*— This is defined as the cumulative engine hours at the completion of BL After Test Oil.

13.2.8 *Total Test Length*—This is defined as the total test hours accumulated from the BL before start time/date through the completion of BL After Test Oil Stage 5.

13.2.9 *Fuel Batch*—This is defined as the batch number for the most recent batch of fuel that has been put into the fuel tank (it is recognized that in most cases a fuel tank will not be completely empty before a new load of fuel is put into the tank, so the fuel in the tank may actually be a mixture of two or more batches).

13.2.10 *Oil Viscosity Measurement*—Measure and report viscosity determinations at 40°C and 100°C on the appropriate form for New Oil and for Aged (Phase II) Oil. Make the viscosity determinations according to Test Method D 445.

13.2.11 *Use of SI Units*—Report all results in (SI) units. Follow the rules for conversion of inch-pound units to SI units as described in IEEE/ASTM SI-10.

13.2.12 *Precision of Reported Units*—Use Practice E 29 for rounding off data. Use the rounding-off method to report data to the required precision.

14. Precision and Bias--The precision and bias of this test procedure for measuring fuel economy has yet to be determined.

15. Keywords

15.1 aged test oil; brake specific fuel consumption; break-in; calibration oil; flying flush; fuel economy; reference oil; sequence VID; spark-ignition automotive engine

**TABLE 1 Sequence VID Fuel Specification**

	Test Method	
Octane, research min	D 2699	96
Pb (organic), mg/L max	D 3237	0.01 max
Sensitivity, min		7.5
Distillation range		
IBP, °C	D 86	23.9 to 35 (75 to 95°F)
10 % point, °C	D 86	48.9 to 57.2 (120 to 135°F)
50 % point, °C	D 86	93.3 to 110 (200 to 230°F)
90 % point, °C	D 86	148.9 to 162.8 (305 to 325 °F)
E.P., °C (max)	D 86	212.8 (415°F)
Sulfur, weight %, max	D 5453	3 min to 15 max
Phosphorous, mg/L, max	D 3231	1.32 (0.005 g/U.S.gal)
RVP, kPa	D 323	60.0 to 63.4 (8.7 to 9.2 psig)
Hydrocarbon composition		
Olefins, % max	D 1319	10
Aromatics, %	D 1319	26 min to 32.5 max
Saturates	D 1319	Report
Existent gum, mg/100mL, max	D 381	5.0
Oxidation stability, minutes	D 525	240 min
Carbon weight fraction	E 191	Report
Hydrogen/Carbon ratio, mol basis	E 191	Report
Net heating value, Btu/lb	D 240	Report
Net heating value, Btu/lb	D 3338	Report
API gravity	D 4052	58.7 min to 61.2 max



TABLE 2 Sequence VID New Engine Cyclic Break-in ^A

	Cycle	
	A	B
Time at Each Step, min	4	1
Time to Decel. to Step A, s		15 max
Time to Accel. to Step B, s	15 max	
Speed, r/min	1500 ± 50	3500 ± 50
Power, kW (hp)	6.0	16.5
Load, N·m (lbf-ft)	38.00 ± 5	45.00 ± 5
Oil Gallery, °C (°F)	80 ± 2	80 ± 2
Coolant In, °C (°F)	80 ± 2	80 ± 5
Coolant Flow, L/min (gal/min)	80 ± 5	80 ± 5
Intake Air Temperature and Humidity	Control Not Required	
Ignition Timing	Controlled by PCM	Controlled by PCM
Exh. Back Press., kPa (in. Hg, abs)	105 (31.0)	Not Specified
AFR	Record	Not Specified
Fuel Pressure to Fuel Rail, kPa (psi)	405 ± 10	405 ± 10
Fuel Temperature to Fuel Rail, °C (°F)	22 ± 2 (72)	22 ± 2 (72)
Fuel Flow, kg/h (lb/h)	Not Specified	Not Specified
BSFC, kg/kW·h (lb/hp·h)	Not Specified	Not Specified

^A The time at each cycle and their acceleration and deceleration times shall be adhered to; target all parameters as close as possible.

TABLE 3 Sequence VID Test Operating Conditions ^A

Parameter	Stage 1	Stage 2	Stage 3	Stage 4	Stage 5	Stage 6
Speed, r/min ^B	2000 ± 5	2000 ± 5	1500 ± 5	695 ± 5	695 ± 5	695 ± 5
Load, Nm ^B	105.0 ± 0.1	105.0 ± 0.1	105.0 ± 0.1	20.0 ± 0.1	20.0 ± 0.1	40.0 ± 0.1
Nominal, Power kW	22.0	22.0	16.5	1.5	1.5	1.5
Gallery, °C ^B	115 ± 2	65 ± 2	115 ± 2	115 ± 2	35 ± 2	115 ± 2
Coolant, °C ^B	109 ± 2	65 ± 2	109 ± 2	109 ± 2	35 ± 2	109 ± 2
Stabilization Time, min	60	60	60	60	60	60

All Stages

Temperatures, °C

Oil Circulation	Record
Coolant Out	Record
Intake Air ^B	29 ± 2
Fuel-to-Flowmeter ^D	20 to 32 (delta from the max stage average reading shall
Fuel-to-Fuel Rail ^B	22 ± 2
Delta Load Cell ^D	Delta from the max stage average shall be ≤6
Oil Heater	205 max

Pressures



	All Stages
Intake Air, kPa	0.05 ± 0.02
Fuel-to-Flowmeter, kPa	110 ± 10
Fuel-to-Fuel Rail, kPa	405 ± 10
Intake Manifold, kPa abs.	Record
Exhaust Back Pressure, kPa abs. ^B	Stages 1-3 = 105.00 ± 0.17 / Stages 4-6 = 104.00 ± 0.17
Engine Oil, kPa	Record
Crankcase, kPa	0.0 ± 0.25
Flows	
Engine Coolant, L/min	80 ± 4
Fuel Flow, kg/h ^B	Record
Humidity, Intake Air, gr/kg of dry air	11.4 ± 0.8
Air-to-Fuel Ratio ^B	14.00:1 to 15.00:1
Air-to-Fuel Ratio ^D	Delta from max stage average reading shall be ≤0.50
Ignition Timing	Controlled by PCM

^A Controlled parameters should be targeted for the middle of the specification range.

^B Critical measurement and control parameters.

^C Counted from the time the temperature set points are initially adjusted to the specific levels.

^D Difference between the maximum stage average reading of the entire test and the individual stage average readings.

TABLE 4

Sequence VID Test Operating Conditions ^A Stage Flush and Stage Aging Hours SI Units

	Stage Flush	Aging Phase I & Phase II
Speed, r/min	1500 ± 5	2250 ± 5
Load, Nm	70.00 ± 0.10	110.00 ± 0.10
Temperatures, °C		
Oil Gallery	115 ± 2	120 ± 2
Coolant In	109 ± 2	110 ± 2
Oil Circulation	Record	Record
Coolant Out	Record	Record
Intake Air	29 ± 2	29 ± 2
Fuel-to-Flowmeter ^C	20 to 32	20 to 32
Fuel-to-Rail	20 ± 2	20 ± 2
Pressures		
Intake Air, kPa	0.05 ± .02	0.05 ± 0.02
Fuel-to-Flowmeter, kPa	110 ± 10	110 ± 10
Fuel-to-Rail, kPa	405 ± 10	405 ± 10

	Stage Flush	Aging Phase I & Phase II
Intake Manifold, kPa abs	Record	Record
Exhaust Back, kPa abs	105.00 ± 0.20	105.00 ± 0.20
Engine Oil, kPa	Record	Record
Flows and Others		
Engine Coolant, L/min	80 ± 4	80 ± 4
Fuel Flow, kg/h	Record	Record
Humidity, Intake Air	Record	Record
gr/kg, of dry air	11.4 ± 0.8	11.4 ± 0.8
Air-to-Fuel Ratio	14.00:1 to 15.00:1	14.00:1 to 15.00:1
Crankcase, Pressure, kF	N/A	0.0 ± 0.25

^A Controlled parameters should be targeted for the middle of the specification range.

^B Counted from the time the temperature set points are initially adjusted to the specific levels.

^C ±3°C within this range.

TABLE 5 VID Test Schedule

		Estimated Elapsed Time, h ^A
BLB-1 Oil Test		
1.	Double flush to BLB-1	1:30
2.	S60, BSFC/fuel flow × 6 at Stage 1 ^B	1:30
3.	S60, BSFC/fuel flow × 6 at Stage 2	1:30
4.	S60, BSFC/fuel flow × 6 at Stage 3	1:30
5.	S60, BSFC/fuel flow × 6 at Stage 4	1:30
6.	S60, BSFC/fuel flow × 6 at Stage 5	1:30
7.	S60, BSFC/fuel flow × 6 at Stage 6	1:30
	Warm-up to Stage Flush	0:30
	Sub Total	11:00
BLB-2 Oil Test		
1.	Double flush to BLB-2	1:30
2.	S60, BSFC/fuel flow × 6 at Stage 1 ^B	1:30
3.	S60, BSFC/fuel flow × 6 at Stage 2	1:30
4.	S60, BSFC/fuel flow × 6 at Stage 3	1:30
5.	S60, BSFC/fuel flow × 6 at Stage 4	1:30
6.	S60, BSFC/fuel flow × 6 at Stage 5	1:30
7.	S60, BSFC/fuel flow × 6 at Stage 6	1:30
	Warm-up to Stage Flush	0:30
	Sub Total	11:00

^A Adhere to stabilization times and times for the 6 replicate BSFC measurements. Warm-up and cool-down times included in flushing elapsed times are estimates.

^B Example: Stabilize 60 min followed by 6 replicate BSFC measurements at 5-min intervals (3 min for set-up, 2 min for time averaged BSFC with Stage 1 operating conditions).

TABLE 6 Calculations of Test Results

- Calculate each 5-minute BSFC measurement using the average speed, load, and fuel flow acquired during the stabilized BSFC measurement cycle as follows

$$\text{BSFC} = (\text{average fuel flow, kg/h})(9549.3)/(\text{average speed, r/min})(\text{average Torque, N}\cdot\text{m}) \quad (1)$$

- Ensure average speed is acquired to a minimum of one whole number (zero decimal places).
 - Ensure average torque is acquired to a minimum of two decimal places.
 - Ensure fuel flow is acquired to a minimum of three decimal places.
- For Stage 1, steps 1 through 6, round and record the 5-minute BSFC measurements to 4 decimal places using ASTM rounding.

3. Average the BSFC measurements of the six steps to 5 decimal places using ASTM rounding. Units for BSFC are kg/kW-h.
4. Multiply the average by the nominal power, stage length, and weight factor (below) for Stage 1 and record the answer to 6 decimal places. The unit for this number is kg of fuel consumed.

Test Stage	Nominal Speed (r/min)	Nominal Power (kW)	Stage Length (h)	Weight Factor
1	2000	21.99	0.5	0.300
2	2000	21.99	0.5	0.032
3	1500	16.49	0.5	0.310
4	695	1.46	0.5	0.174
5	695	1.46	0.5	0.011
6	695	2.91	0.5	0.172

5. Perform calculation steps 1, 2, 3, and 4 for the remaining test stages (2 to 6) using the respective nominal power, stage length, and weight factors.
6. Total the mass fuel consumption values for all 6 stages.
7. Complete the total fuel consumed calculation detailed in Steps 1 to 6 above for the BL Before Test Oil 1, BL Before Test Oil 2, Test Oil Phase I, Test Oil Phase II, and BL After Test Oil.
8. Compute the test oil fuel economy improvement (FEI) as follows:

$$\% \text{ FEI Test Oil Phase I} = \left\{ \frac{[(\text{BL Before 2} \times 80\%) + (\text{BL After} \times 20\%) - \text{Test Oil}]}{[(\text{BL Before 2} \times 80\%) + (\text{BL After} \times 20\%)]} \right\} \times 100$$

(2)

$$\% \text{ FEI Test Oil Phase II} = \left\{ \frac{[(\text{BL Before 2} \times 10\%) + (\text{BL After} \times 90\%) - \text{Test Oil}]}{[(\text{BL Before 2} \times 10\%) + (\text{BL After} \times 90\%)]} \right\} \times 100$$

(3)

9. Adjust the FEI result(s) on non-reference oil tests for the stand/engine severity in accordance with Annex A7.

TABLE 7 Calculation of Unweighted Baseline Shift

1. Calculate each 5-min BSFC measurement using the average speed, load, and fuel flow acquired during the stabilized BSFC measurement cycle as follows:

$$\text{BSFC} = \frac{(\text{average fuel flow, kg/h})(9549.3)}{(\text{average speed, r/min})(\text{average Torque, N}\cdot\text{m})} \quad (1)$$

- a. Ensure average speed is acquired to a minimum of one whole number (zero decimal places).
 - b. Ensure average load is acquired to a minimum of two decimal places.
 - c. Ensure fuel flow is acquired to a minimum of three decimal places.
2. For Stage 1, steps 1 through 6, round and record the 5-min BSFC measurements to 4 decimal places using ASTM rounding.
 3. Average the BSFC measurements of the six steps to 5 decimal places using ASTM rounding. Units for BSFC are kg/kW-h.
 4. Multiply the average by the shown nominal power and stage length from Table 6 for Stage 1 and record the answer to 6 decimal places. The unit for this number is kg of fuel consumed.
 5. Perform calculation steps 1, 2, 3, and 4 for the remaining test stages (2 to 6) using the respective nominal power and stage lengths.
 6. Total the mass fuel consumption values for all 6 stages.
 7. Complete the total fuel consumed calculation detailed in Steps 1 to 6 above for the BL Before Test Oil 1, BL Before Test Oil 2, and BL After Test Oil.
 8. Compute the baseline shift results as follows:

$$\% \text{ Unweighted Baseline Shift BLB1 to BLB2} = \frac{\{[\text{Unweighted BLB1} - \text{Unweighted BLB2}]\}}{\text{Unweighted BLB1}} \times 100 \quad (2)$$

$$\% \text{ Unweighted Baseline Shift BLB2 to BLA} = \frac{\{[\text{Unweighted BLB2} - \text{Unweighted BLA}]\}}{\text{Unweighted BLB2}} \times 100 \quad (3)$$

TABLE 8 Sequence VID Reference Oil Precision Statistics ^A

Variable	Intermediate Precision		Reproducibility	
	s_{ip} ^B	imp.	S_R ^B	R
Fuel Econ Improvem				
TBD	TBD	TBD	TBD	TBD
TBD	TBD	TBD	TBD	TBD

^A statistics are based on results obtained on TBD

^B s = standard deviation.

ANNEXES

A1. THE ROLE OF THE ASTM TEST MONITORING CENTER AND THE CALIBRATION PROGRAM

A1.1 Nature and Functions of the ASTM Monitoring Center (TMC)

A1.1.1 The TMC² is a non-profit organization located in Pittsburgh, Pennsylvania and is staffed to administer engineering studies; conduct laboratory visits; perform statistical analyses of reference oil test data; blend, store, and ship reference oils; and provide the associated administrative functions to maintain the referencing calibration program for various lubricant tests as directed by ASTM Subcommittee D02.B0 and the Test Monitoring Board. The TMC coordinates its activities with the test sponsors, the test developers, the surveillance panels, and the testing laboratories. Contact TMC through the TMC Administrator at:

ASTM Test Monitoring Center
6555 Penn Avenue
Pittsburgh, PA 15206-4489

A1.2 Rules of Operation of the ASTM TMC

A1.2.1 The TMC operates in accordance with the ASTM Charter, the ASTM Bylaws, the Regulations Governing ASTM Technical Committees, the Bylaws Governing ASTM Committee D02, and the Rules and Regulations Governing the ASTM Test Monitoring System.

A1.3 Management of the ASTM TMC

A1.3.1 The management of the Test Monitoring System is vested in the Test Monitoring Board (TMB) elected by Subcommittee D02.B0. The TMB selects the TMC Administrator who is responsible for directing the activities of the TMC staff.

A1.4 Operating Income of the ASTM TMC

A1.4.1 The TMC operating income is obtained from fees levied on the reference oils supplied and on the calibration tests conducted. Fee schedules are established and reviewed by Subcommittee D02.B0.

A1.5 Conducting a Reference Oil Test

A1.5.1 For those laboratories that choose to utilize the services of the TMC in maintaining calibration of test stands, full-scale calibration testing shall be conducted at regular intervals. These full-scale tests are conducted using coded reference oils supplied by the TMC. It is a laboratory's responsibility to keep the on-site reference oil inventory at or above the minimum level specified by the TMC test engineers.

A1.5.2 When laboratory personnel decide to run a reference calibration test, they shall request an oil code from the responsible TMC engineer. Upon completion of the reference oil test, the data shall be sent in summary form (use TMC-acceptable forms) to the TMC by telephone facsimile transmission, or some

²ASTM Test Monitoring Center, 6555 Penn Avenue, Pittsburgh, PA 15206 4489. For other information, refer to Research Report RR: D02:1469, Sequence VIB Test Development. This research report and this test method are supplemented by Information Letters and Memoranda issued by the ASTM TMC. This edition incorporates revisions in all Information Letters through No. 05-1.

other method acceptable to the TMC. The TMC will review the data and contact the laboratory engineer to report the laboratory's calibration status. All reference oil tests, whether aborted, invalidated, or successfully completed, shall be reported to the TMC. Subsequent to sending the data in summary form to the TMC, the laboratory is required to submit to the TMC the written test report specified in the test method.

A1.6 New Laboratories

A1.6.1 Laboratories wishing to become part of the ASTM Test Monitoring System will be requested to conduct reference oil tests to ensure that the laboratory is using the proper testing techniques. Information concerning fees, laboratory inspection, reagents, testing practices, appropriate committee membership, and rater training can be obtained by contacting the TMC Administrator.

A1.7 Introducing New Sequence VID Reference Oils

A1.7.1 The calibrating reference oils produce various fuel economy results. When new reference oils are selected, member laboratories will be requested to conduct their share of tests to enable the TMC to establish the proper industry average and test acceptable limits. The ASTM D02.B0.01 Sequence VI Surveillance Panel will require a minimum number of tests to establish the industry average and test acceptance targets for new reference oils.

A1.8 TMC Information Letters

A1.8.1 Occasionally it is necessary to change the procedure, and notify the test laboratories of the change, prior to consideration of the change by either Subcommittee D02.B0 on Automotive Lubricants, or ASTM Committee D02 on Petroleum Products and Lubricants. In such a case, the TMC will issue an Information Letter. Information Letters are balloted by Subcommittee D02.B0. By this means, the Society due process procedures are applied to these Information Letters.

A1.8.2 The review of an Information Letter prior to its original issue will differ according to its nature. In the case of an Information Letter concerning a part number change which does not affect test results, the TMC is authorized to issue such a letter. Long-term studies by the Surveillance Panel to improve the test procedure through improved operation and hardware control may result in a recommendation to issue an Information Letter. If obvious procedural items affecting test results need immediate attention, the test sponsor and the TMC will issue an Information Letter and present the background and data to the Surveillance Panel for approval prior to the semiannual Subcommittee D02.B0 meeting.

A1.8.3 Authority for the issuance of Information Letters was given by the committee on Technical Committee Operations in 1984, as follows: "COTCO recognizes that D02 has a unique and complex situation. The use of Information Letters is approved providing each letter contains a disclaimer to the effect that such has not obtained ASTM consensus. These Information Letters should be moved to such consensus as rapidly as possible."

A1.8.4 Information Letters pertaining to this procedure issued prior to 02-1 are incorporated into this test method. A listing of such Information Letters, and copies of the letters, may be obtained from the TMC. Information Letters issued subsequent to this date may also be obtained from the TMC.

A1.9 TMC Memoranda

A1.9.1 In addition to the aforementioned Information Letters, supplementary memoranda are issued. These are developed by the TMC, and distributed to the Sequence VI Surveillance Panel and to participating laboratories. They convey such information as batch approvals for test parts or materials, clarification of the test procedure, notes and suggestions of the collection and analysis of special data that the TMC may request, or for any other pertinent matters having no direct effect on the test performance, results, or precision and bias.

A1.10 Precision Data

A1.10.1 The TMC determines the current Sequence VID test precision by analyzing results of calibration tests conducted on reference oils. Current precision data can be obtained from the TMC.

A2. DETAILED SPECIFICATIONS AND DRAWINGS OF APPARATUS

Figs. A2.1–A2.24 presents the detailed specifications and drawings of apparatus. ^{10,3}

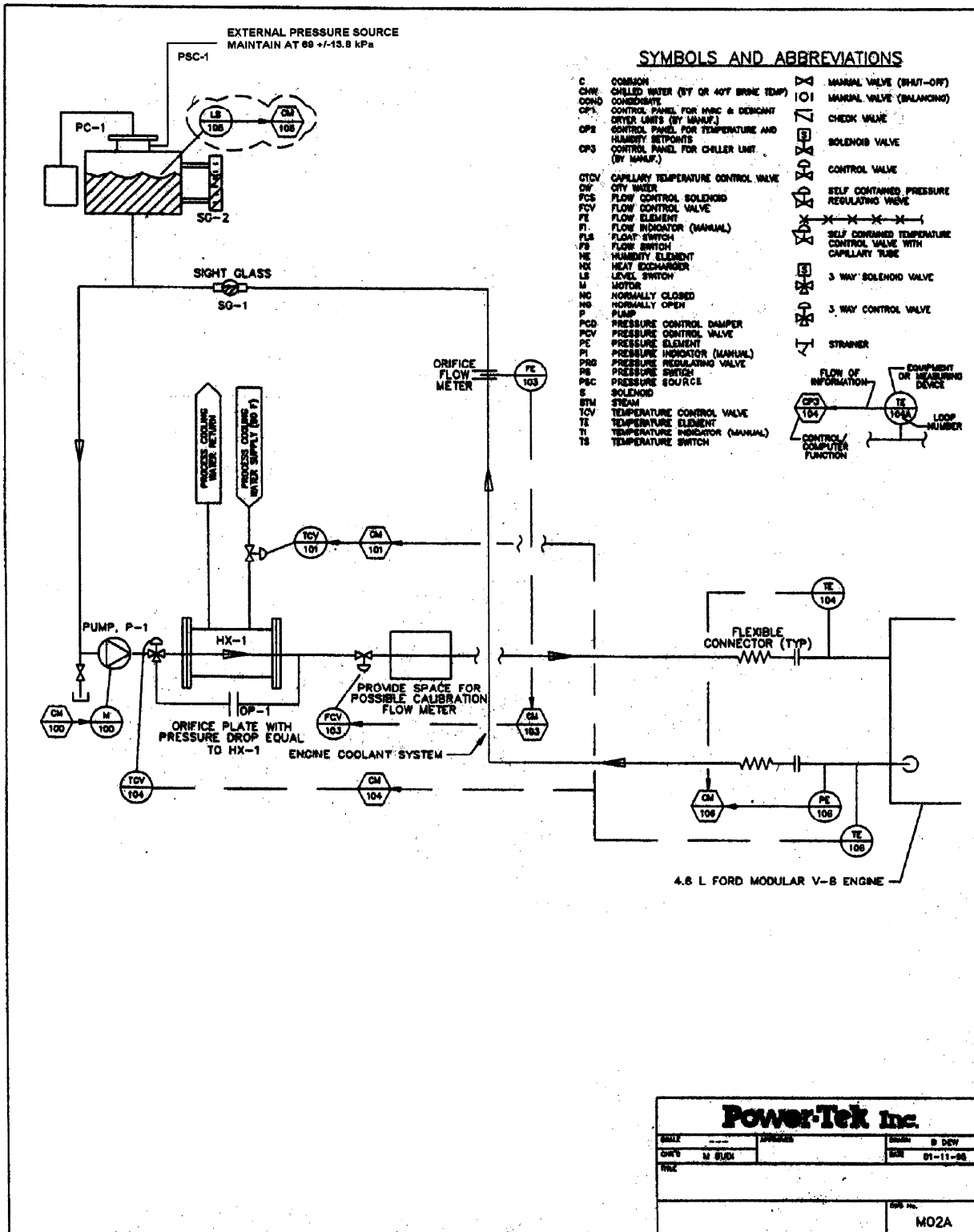

Fig A2.1 Typical Engine Cooling System

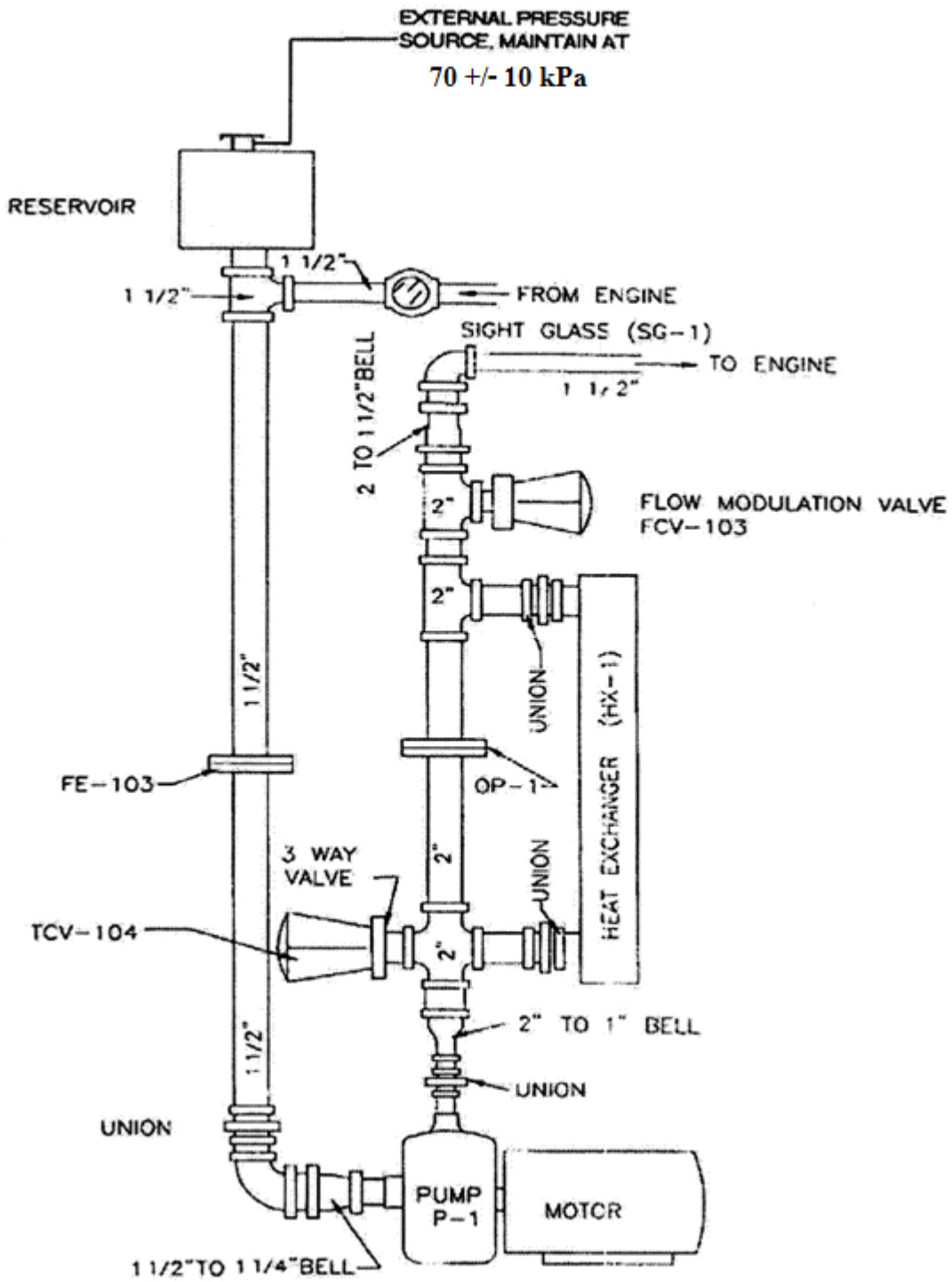

FIG. A2.2 Typical Engine System in Air-To-Close Configuration

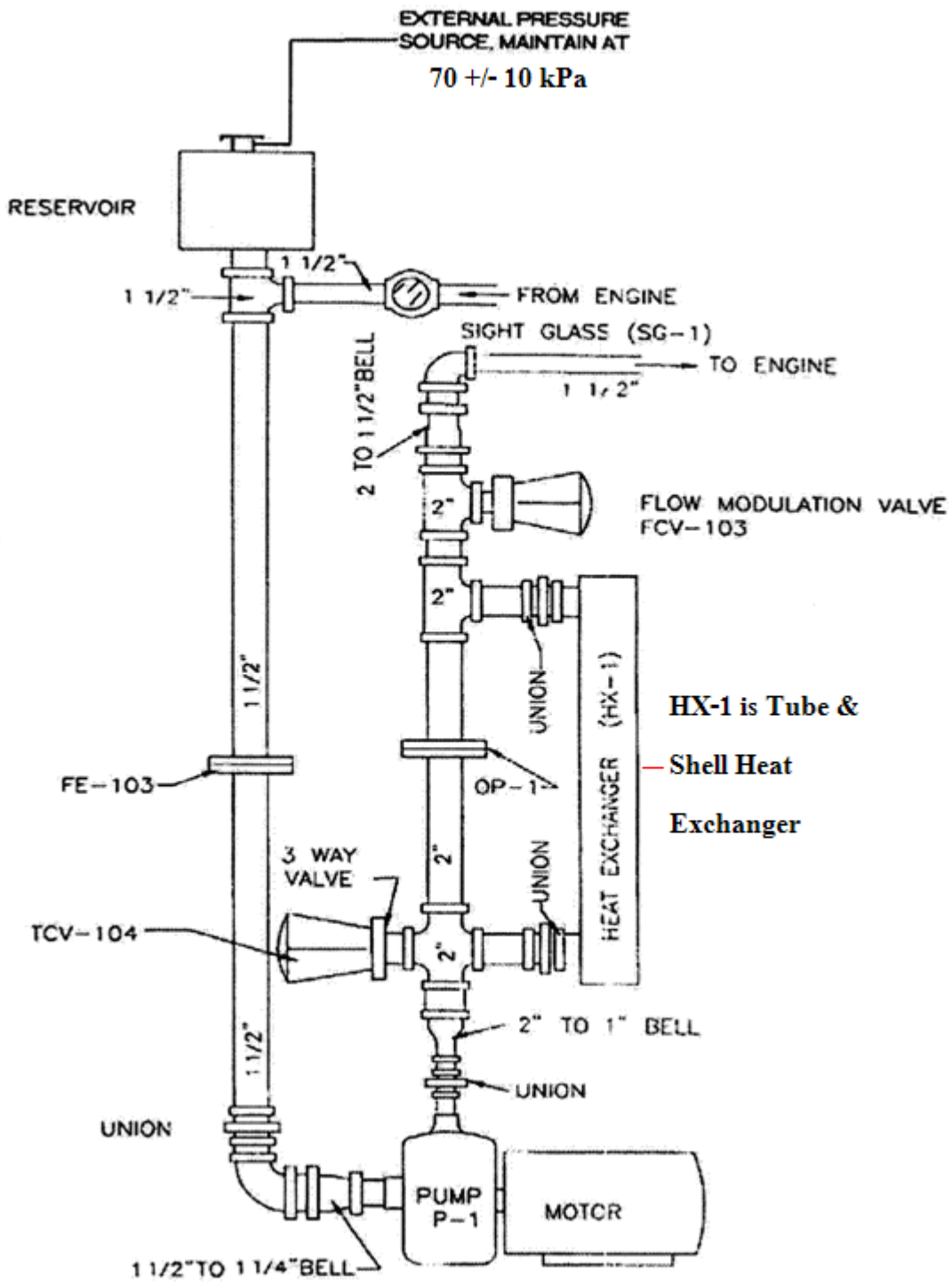

FIG. A2.3 Alternative Engine System Configuration



Fig. A2.4 Water Pump Plate

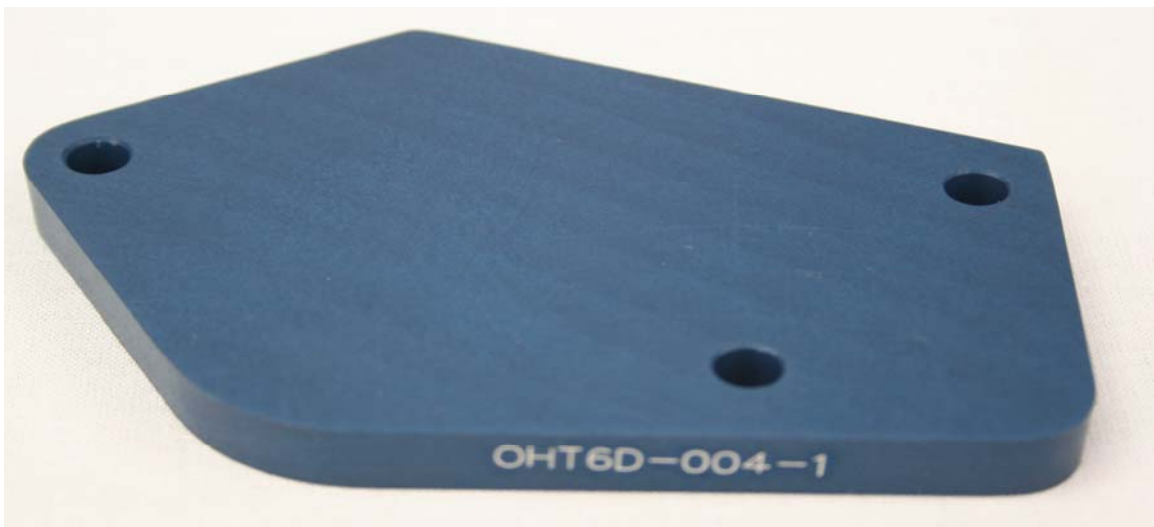



FIG. A2.5 Coolant System Block-off Plate

Normal Operating Mode

 Closed valve

 Open valve

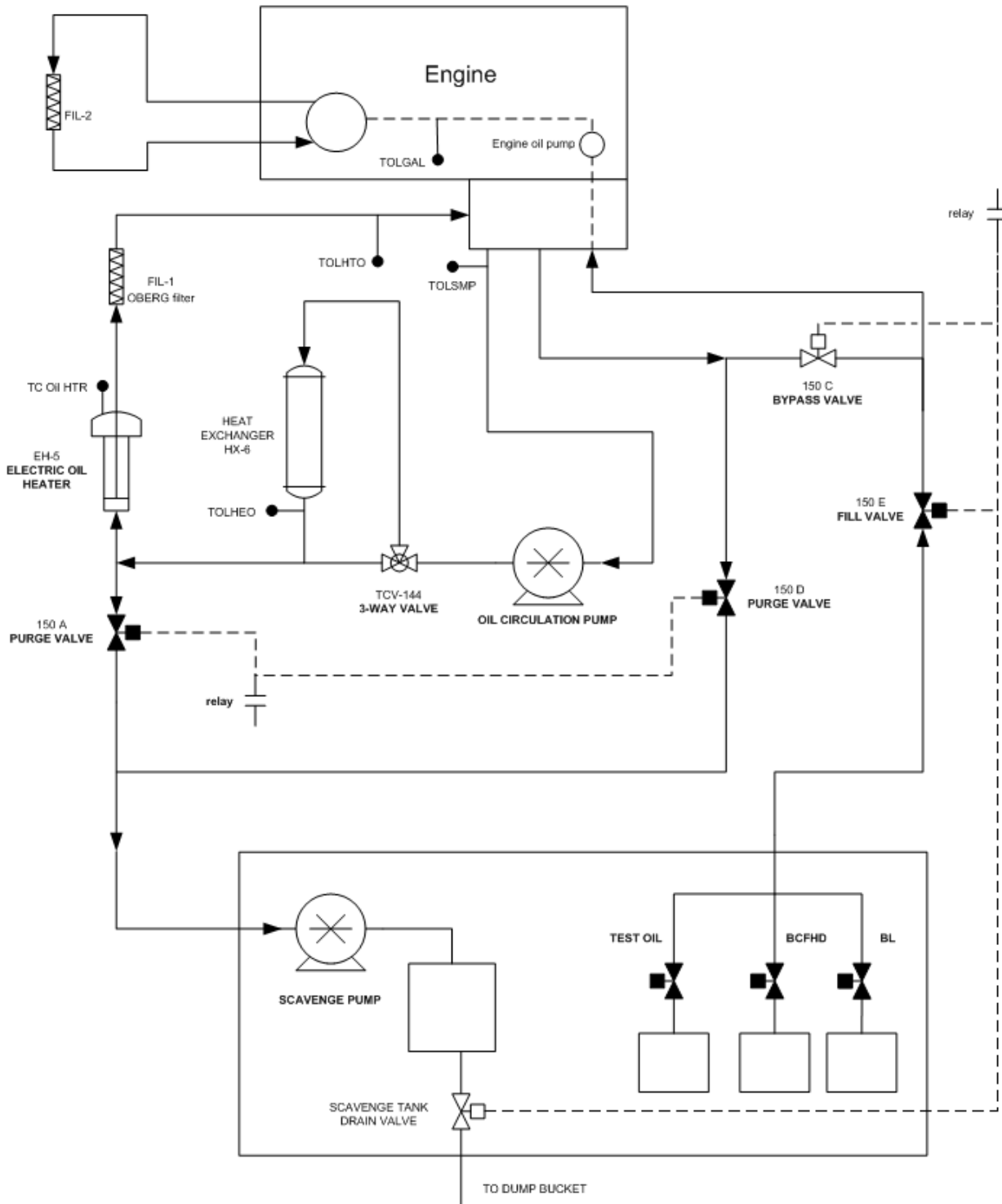
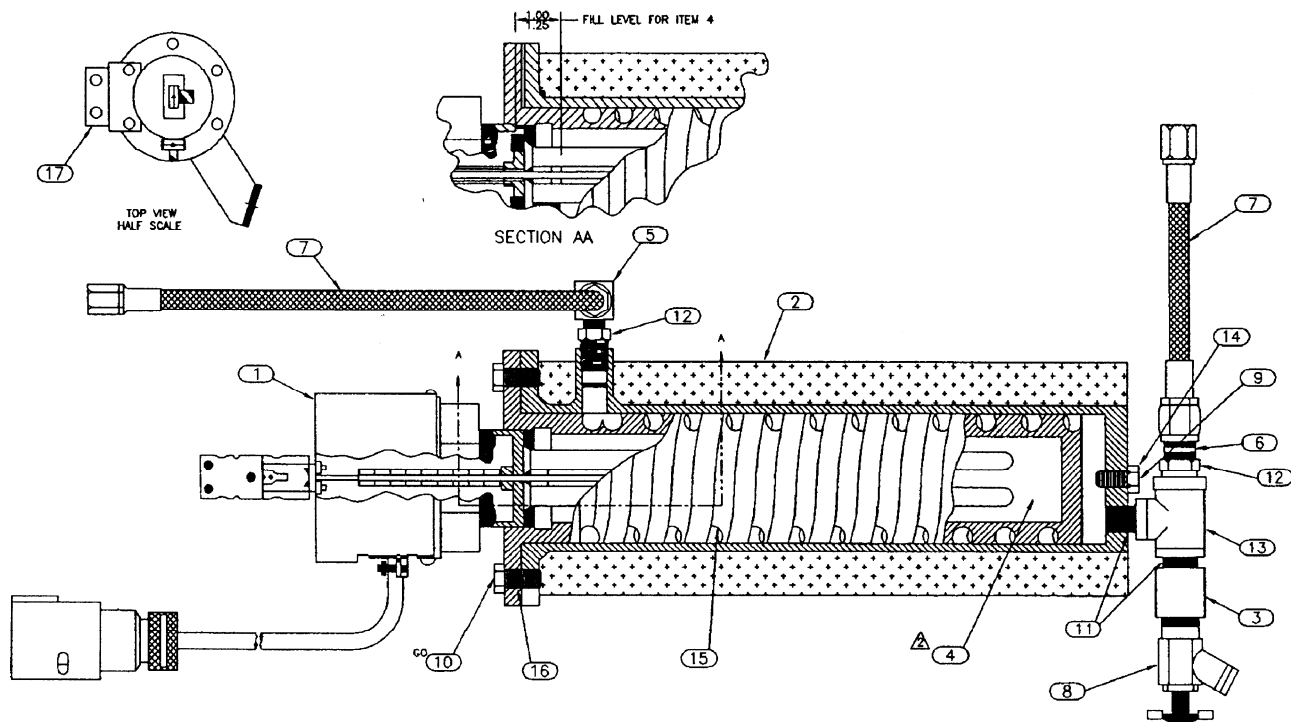
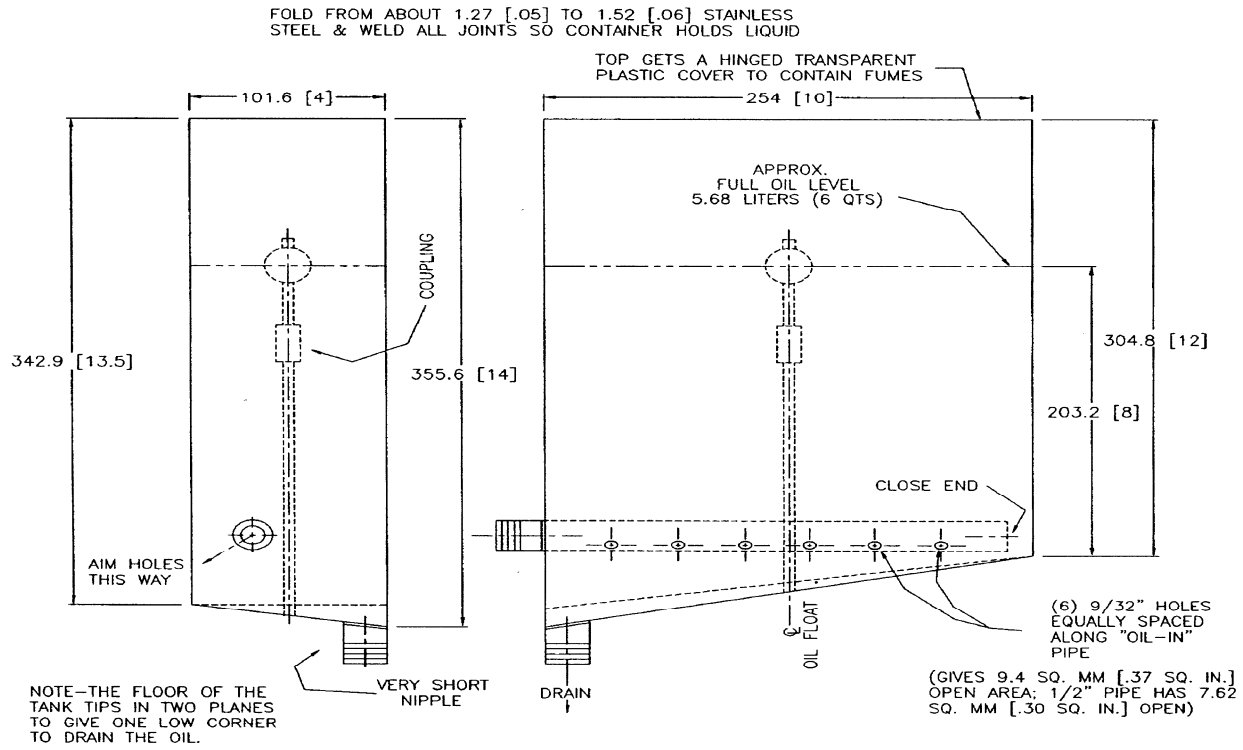

FIG. A2.6 External Oil System



- 3. TWO ROWS X NOT ASSEMBLED
- ⚠️ FILL WITH APPROXIMATELY 12LB 11OZ OF CORRO-CAST (ITEM 4)
- 1. OIL CAPACITY 425-475 CC INCLUDING HOSE & FITTINGS AS SHOWN

FIG. A2.7 Thermocouple in Oil Heater



NOTE—DIMENSIONS ARE IN MILLIMETERS AND [INCHES]

"OIL-IN" BLACK 1/2" PIPE, "OIL DRAIN" SHORT 1/2" NIPPLE

STAND PIPE TO HOLD FLOAT SWITCH IS 1/4" PIPE; USE A SHORT NIPPLE OF SELECTED LENGTH BETWEEN FLOAT SWITCH AND 1/4" COUPLING TO GET EXACT LEVEL NEEDED TO TRIP SWITCH AT 5.68 LITERS (6 QTS.).

TANK IS LATER MOUNTED BY TACK WELDING AN ANGLE IRON LEG ALONG ONE OF THE VERTICLE CORNERS AND WELDING A SQUARE PLATE AT THE BOTTOM OF THE LEG, WHICH CAN BE BOLTED TO THE FLOOR OR OTHER HORIZONTAL SURFACE

FIG. A2.8 Typical Oil Dump Tank



FIG. A2.9 Sequence VID Pan Modifications

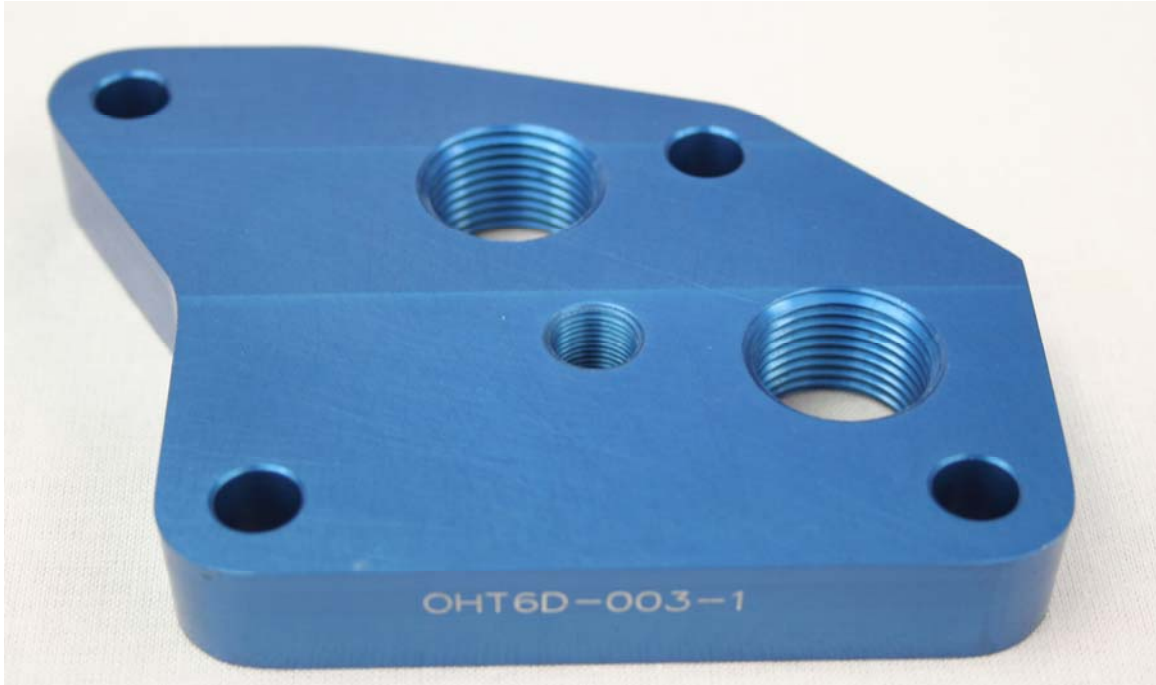
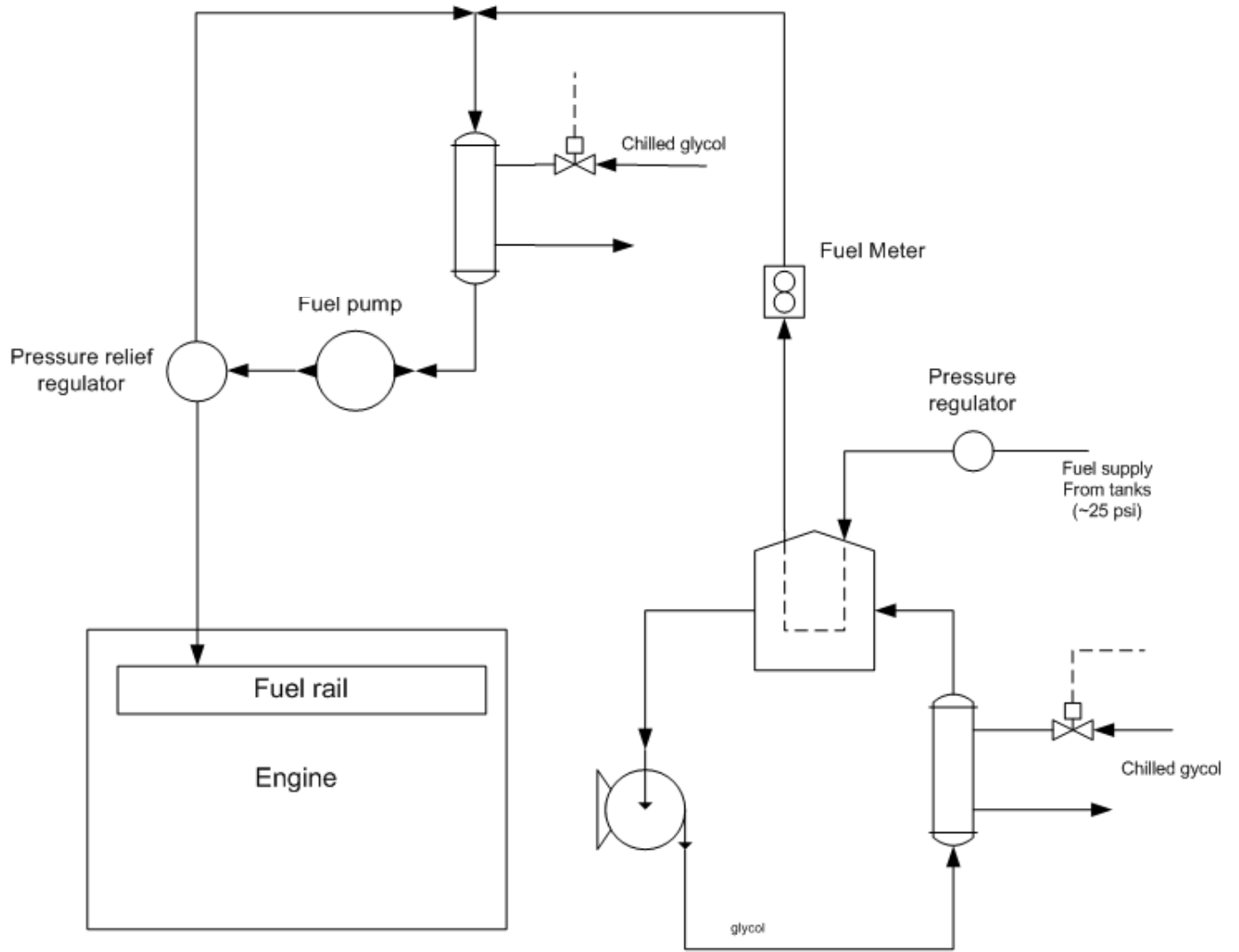

FIG. A2.10 Oil Filter Adapter Assembly

Position VI-D Fuel System Diagram



2.11 Typical Fuel Delivery System

Fig.

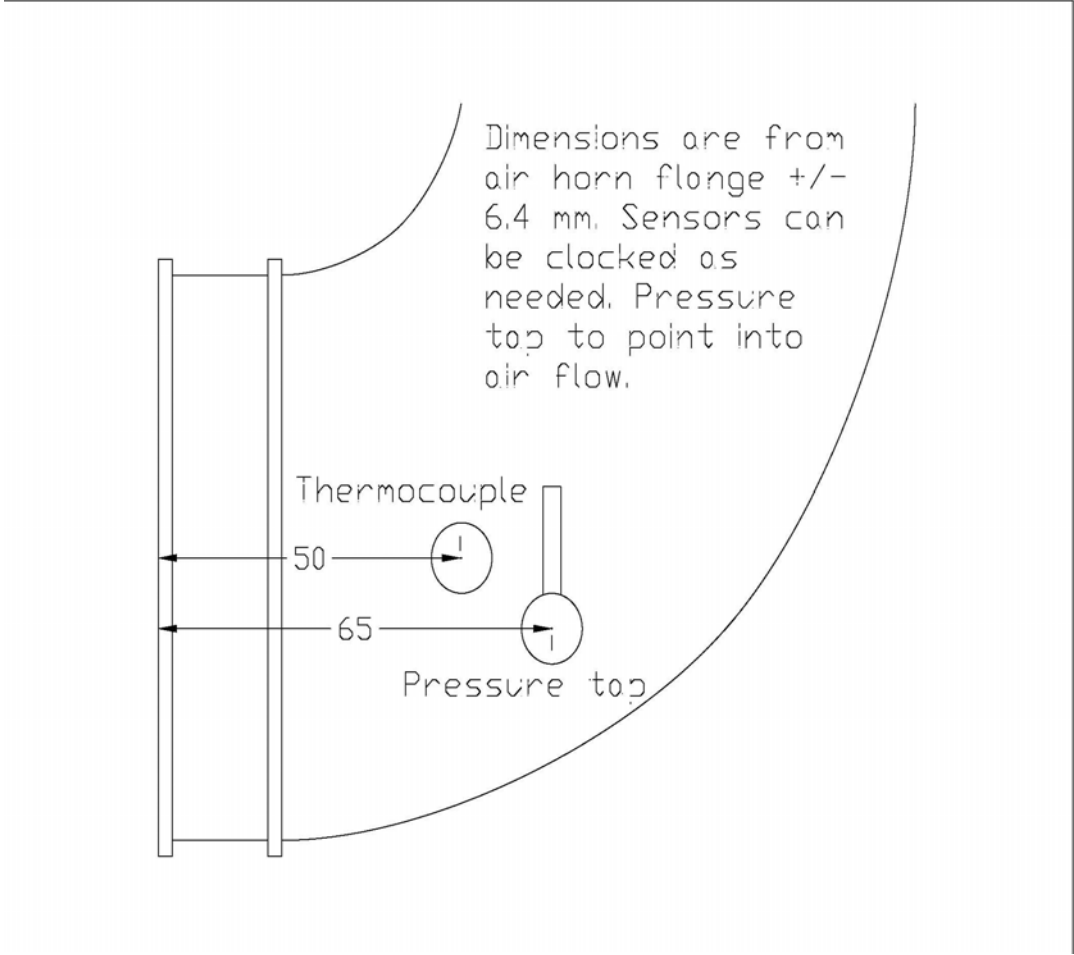

FIG. A2.12 Air Intake Tap Locations

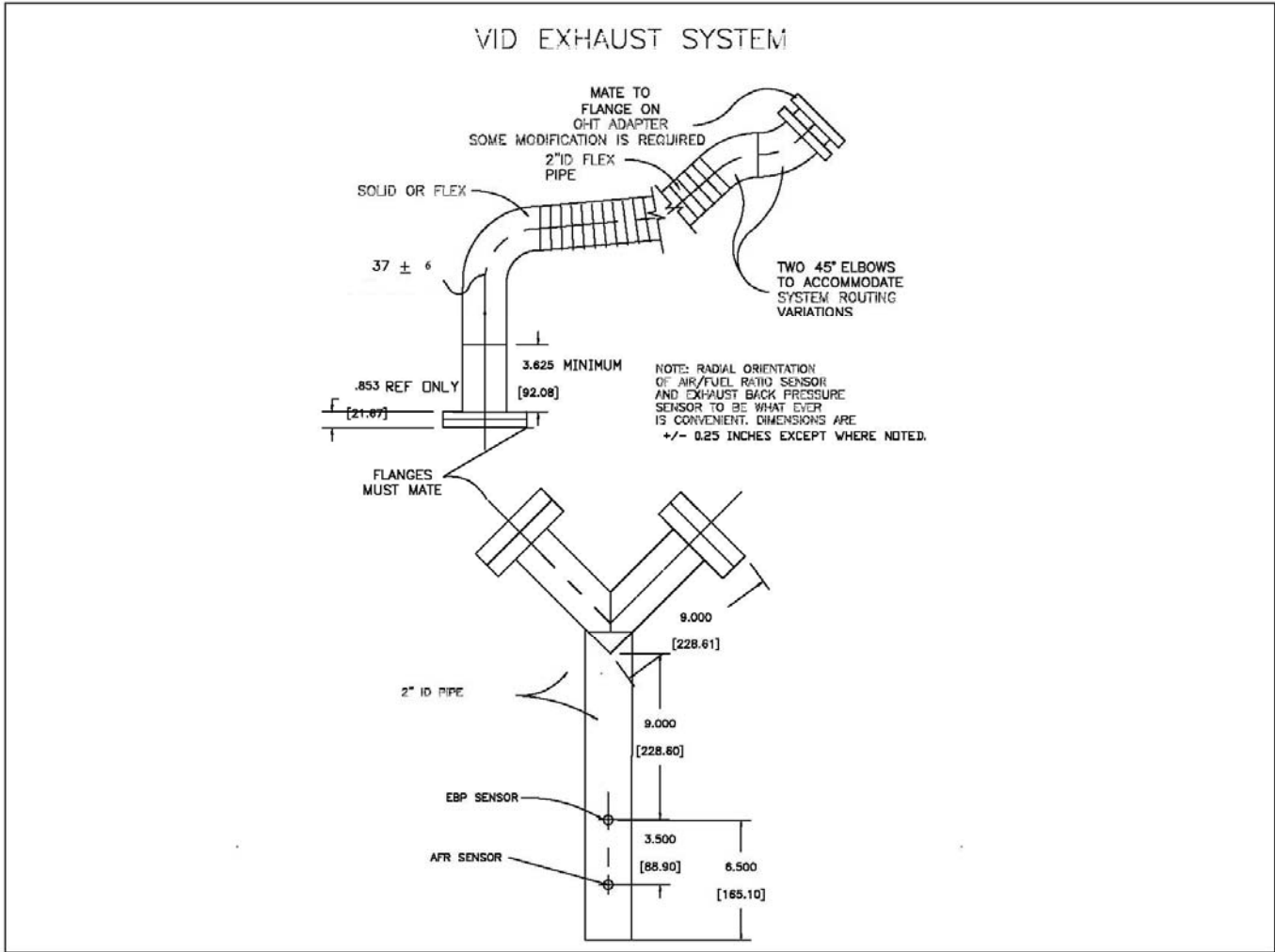

FIG. A2.13 Laboratory Exhaust System



FIG. A2. 14 TAKE DOWN TUBE, R.H. ASSY.

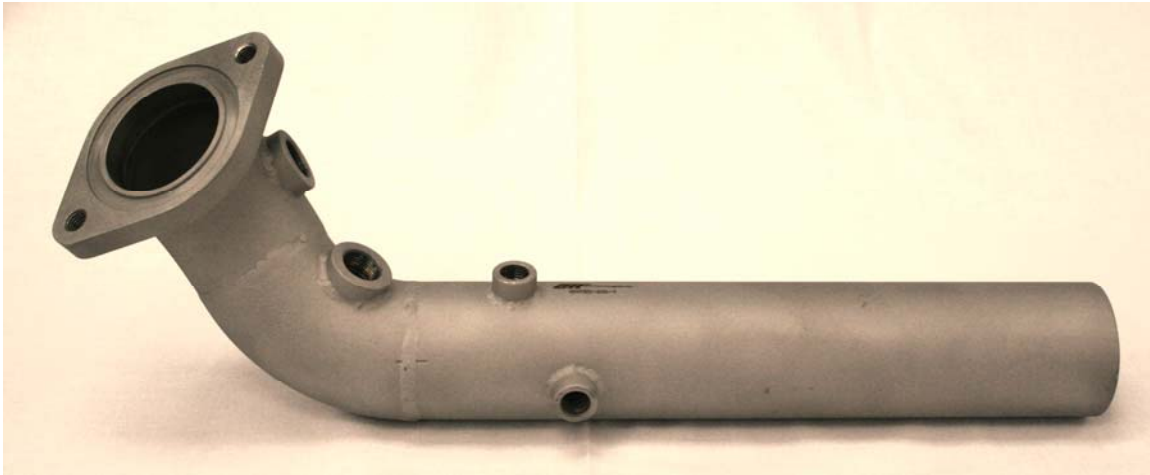
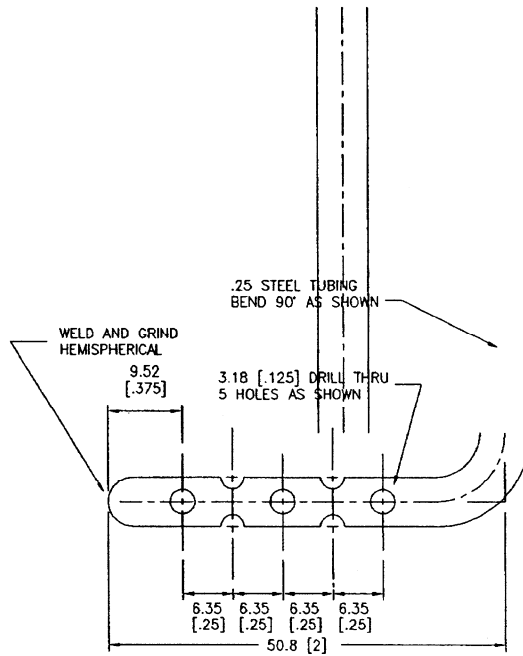
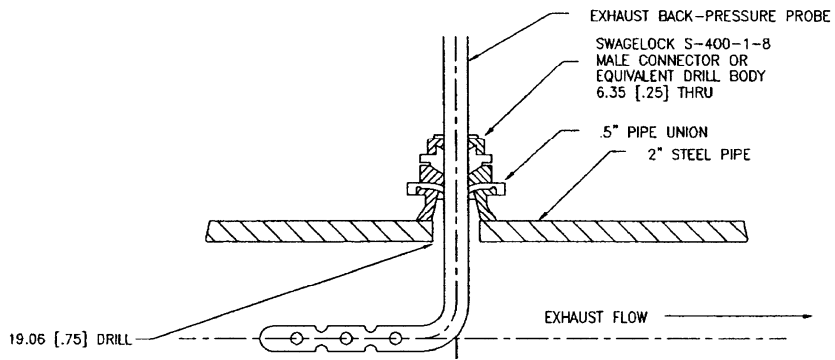

FIG. A2. 15 TAKE DOWN TUBE, L.H. ASSY.



PROBE DETAIL



NOTE: BEND EXTERNAL TUBING SEGMENT AFTER ASSY PARALLEL WITH PROBE AXIS AS SHOWN. THIS PERMITS VISUAL ALIGNMENT CHECK DURING OPERATION.

NOTE: PROBE C TO BE COINCIDENT WITH PIPE C

ASSEMBLY DETAIL

DIMENSIONS ARE IN MILLIMETERS AND [INCHES]

THABY SEPT94
C:DIESEL\EXBXP
REV 23JAN95

FIG. A2.16 Exhaust Back Pressure Probe

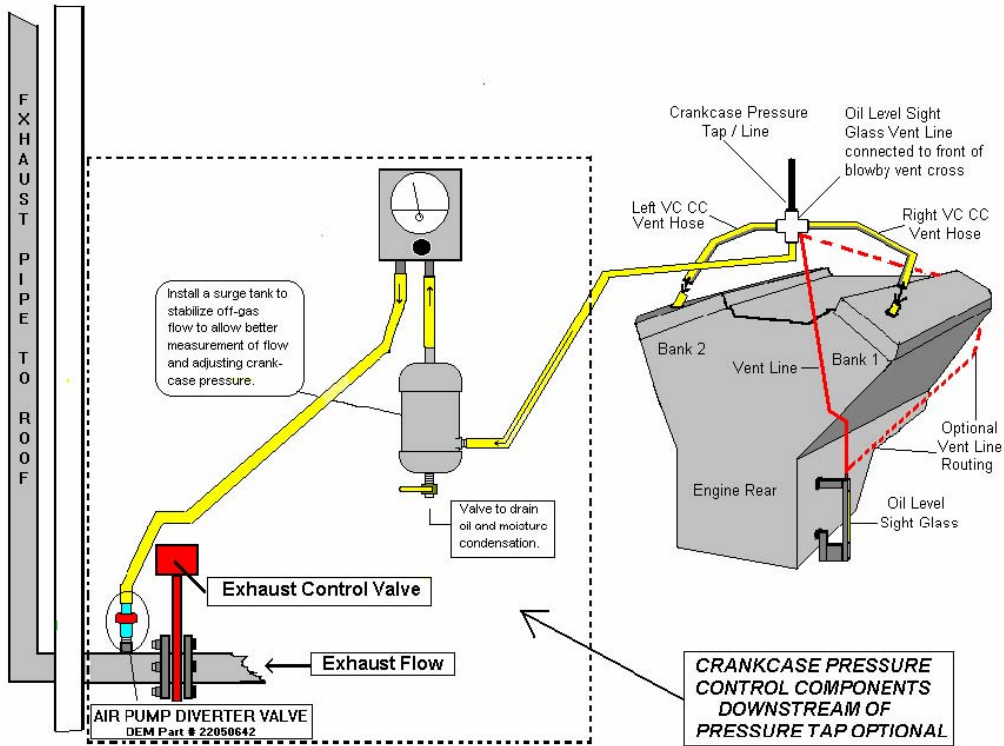

FIG. A2.17 Typical Crankcase Pressure and Blow-by Ventilation System



FIG. A2.18 FLYWHEEL TORQUE TOOL



FIG. A2.19 CRANKSHAFT HOLDING TOOL

A3. OIL HEATER CERROBASE REFILL PROCEDURE

A3.1 The cylinder that holds the Cerrobases, Chromalox heater element, and thermocouple is called the cartridge. Take the cartridge out of its insulated case at the engine by backing out six 3/8-16 by 7/8 hex head screws. Hold the cartridge upright in a vise at the work bench.

A3.2 Remove the cable cover and cable connections at the heater element. It is a good idea to make a sketch of the cable connections and shorting bars because this arrangement is not always the same. Remove two 1/8NPT pipe plugs at the top of the cartridge so the Cerrobases chamber will be fully vented to atmosphere.

A3.3 Using an acetylene torch, play it on all accessible surfaces of the cartridge until the Cerrobases is completely melted. The Cerrobases shall be liquid. Check with a pre-heated welding rod through one of the 1/8NPT holes. Put a wrench on the 3-in. hex flat and try to remove the heater element from the cartridge. Again, be sure the Cerrobases is completely melted before screwing out on the 3-in. hex. Cerrobases melts at 255°F. Don't force the hex. Keep heating the cartridge and pumping the wrench until the heater element can be backed out of the cartridge.

A3.4 After removing the heater element, lay it aside and pour the melted Cerrobases out of the cartridge into a suitable, dry receiver. Keep heat on the cartridge and be sure it is completely empty of Cerrobases and oxide. Clean all surfaces of the cartridge thoroughly by heating and wire brushing.

A3.5 Hold the heater element in a vise across the hex flats. Remove the thermocouple. Play the torch along the heater elements and wire brush, as necessary, to remove oxide.

A3.6 Replace the cartridge in the vise and heat it with a torch. If the Cerrobases is clean and bright, reuse it. In any case, melt 8.5 lb of Cerrobases, enough to fill the cartridge about two-thirds full. A good way to melt the Cerrobases is to hold the ladle in a vise. Heat the ladle and Cerrobases until melted, remembering to put occasional heat on the cartridge to keep Cerrobases in the cartridge liquid. Pour from the ladle carefully to avoid splashing. Avoid thermal shock by keeping all parts coming into contact with Cerrobases well heated.

A3.7 Preheat the heater element and immerse it in the liquid Cerrobases. Pull up on the 3-in. hex to secure the assembly. Screw the heater funnel into one of the 1/8 NPT holes. The heater funnel is made up of a heavy wall funnel welded to a 3 in. long, 1/8-in. pipe nipple.

NOTE A3.1—Do not over-torque the 3-in. hex because differential contraction can lock the hex.

A3.8 Keep playing the torch on the cartridge while working and when the heater funnel has been screwed in place, heat it also. Finish filling the cartridge with Cerrobases. Look through the open 1/8 NPT hole to see the Cerrobases liquid level and pour Cerrobases through the funnel until the liquid level is within 2.250 and 2.375 in. of the top of the plug. As shown on TD-428, this will leave expansion space for the Cerrobases in the cartridge. If the cartridge should be overfilled use the following technique to remove Cerrobases.

A3.8.1 Cool a piece of welding rod in ice water. Wipe the rod completely dry and immerse it in the Cerrobased. Pull it out. Some Cerrobased will have solidified and frozen to the rod. Slide Cerrobased off the rod and repeat as necessary to get the liquid level to within 1/4 in. of the plug.

A3.9 Use a new thermocouple. Thread eleven heat insulation beads on the thermocouple. Check the Cerrobased with welding rod to be sure it is liquid. Pre-heat the thermocouple and push it into the Cerrobased through the center, 0.250-in. diameter drilled hole. The eleven beads will serve as a gage to determine immersion depth of the thermocouple. Ensure the 0.250-in. hole is clean. In the final assembly clearance between this hole and the thermocouple will be the only vent between the Cerrobased and atmosphere. Tie the thermocouple down, otherwise, the thermocouple will float out of the liquid Cerrobased.

A3.10 Let the cartridge cool to room temperature. Remove the heater funnel and install two 1/8 NPT pipe plugs. Connect the cable and shorting bars in their original arrangement. Replace the thermocouple connector and cable cover. Reinstall the cartridge in its insulated case at the engine.

A4. ENGINE PART NUMBER LISTING

A4.1 Table A4.1 lists other specified engine parts.

TABLE A4.1 Other Specified Engine Parts

Part Name	Part No.
Mass Air Meter	OHT6D-040-1
Throttle Body	OHT6D-041-1
Throttle Body Bolt	11519903
Throttle Body Gasket	12593303
Fuel Injector	OHT6D-042-1
Spark Plug	OHT6D-043-1
Crankshaft Sensor	OHT6D-044-1
Camshaft Sensor	OHT6D-045-1
Knock Sensor	OHT6D-046-1
Pre-Cat Sensor	OHT6D-047-1
Coolant Sensor	OHT6D-048-1
Exhaust Shield	12580703
Shield Bolt	24505C08
Exhaust Insulator	12581803
Upper Intake	12597803
Lower Intake	12571C03

Part Name	Part No.
Intake Gasket Kit	12595203
Exhaust Gasket	12571103
Exhaust Insulator, Upper	12582603
Exhaust Insulator, Lower	12616603
Fuel Rail	12572886
Engine Air Cleaner Assembly	SEE DESCRIPTION IN DOCUMENT BODY
Air Cleaner Element	GM 25735595
Engine Wiring Harness	OHT6D-011-2
Engine Control Module	OHT6D-012-4 (Revision 3)
Exhaust Manifold (R.H.)	12571101
Exhaust Manifold (L.H.)	12571102
Exhaust Adapter, (R.H.)	OHT6D-010-1
Exhaust Adapter, (L.H.)	OHT6D-009-1
Engine Flywheel	OHT3H-020-X
Engine Mount Front	OHT3H-026-1
Engine Mount Rear	OHT3H-025-1
Engine Mount Isolators	TBD

^A Supplied with engine.

^B Required modification.

^C Shall be purchased from CPD.

A5. SAFETY PRECAUTIONS

A5.1 General Information

A5.1.1 The operating of engine tests can expose personnel and facilities to a number of safety hazards. It is recommended that only personnel who are thoroughly trained and experienced in engine testing should undertake the design, installation, and operation of engine test stands.

A5.1.2 Each laboratory conducting engine tests should have their test installation inspected and approved by their Safety Department. Personnel working on the engines should be provided with the proper tools, be alert to common sense safety practices, and avoid contact with moving or hot engine parts, or Both. Guards should be installed around all external moving or hot parts. When engines are operating at high speeds, heavy duty guards are required and personnel should be cautioned against working alongside the engine and coupling shaft. Barrier protection should be provided for personnel. All fuel lines, oil lines, and electrical wiring should be properly routed, guarded, and kept in good order. Scraped knuckles, minor burns, and cuts are common if proper safety precautions are not taken. Safety masks or glasses should always be worn by personnel working on the engines and no loose or flowing clothing shall be worn near running engines.

A5.1.3 The external parts of the engine and the floor area around the engines should be kept clean and free of oil and fuel spills. In addition, the working areas should be free of all tripping hazards. In case of injury, no matter how slight, first aid attention should be applied at once and the incident reported. Personnel should be alert for leaking fuel or exhaust gas. Leaking fuel represents a fire hazard and exhaust gas fumes are noxious. Containers of oil or fuel cannot be permitted to accumulate in the testing area.

A5.1.4 The test installation should be equipped with a fuel shut-off valve which is designed to automatically cut off the fuel supply to the engine when the engine is not running. A remote station for cutting off fuel from the test stand is recommended. Suitable interlocks should be provided so that the engine is automatically shut down when any of the following events occur: dynamometer loses field current, engine over speeds, engine oil pressure is lost, exhaust system fails, room ventilation fails, or the fire protection system activates. Consider an excessive Vibration pick-up interlocks if equipment operates unattended. Fixed fire protection equipment should be provided.

A5.1.5 ASTM Sequence Tests use chemicals to clean engines between tests. Some of these chemicals require that personnel wear face masks, dust breathers, and gloves as exothermic reactions are possible. Emergency showers and face rinse facilities should be provided when handling such materials.

A5.2 Physical and Chemical Hazards List

A5.2.1 Physical Hazards:

A5.2.1.1 Hot engine parts, exhaust pipe.

A5.2.1.2 Rotating engine/test stand parts (belts, pulleys, shafts).

A5.2.1.3 Electrical shock.

A5.2.1.4 Noise.

A5.2.2 Chemical and Materials Hazards:

A5.2.2.1 Gasoline—(Unleaded):

- (1) Extremely flammable. Vapors harmful if inhaled. Vapors may cause flash fire.
- (2) Keep away from heat, sparks, and open flames.
- (3) Keep containers closed; use positive shut off valves on fuel lines.
- (4) Use with adequate ventilation.
- (5) Avoid buildup of vapors and eliminate all sources of ignition, especially non-explosion proof electrical apparatus and heaters.
- (6) Avoid prolonged breathing of vapor.
- (7) Avoid prolonged or repeated skin contact.

A5.2.2.2 Organic Solvent (Penmul L460):

- (1) Before opening the container, relieve pressure. Keep the container tightly closed when not in use.
- (2) Store at moderate temperatures and keep away from heat, sparks, open flame, and strong oxidizing agents.
- (3) Use dry chemical, foam or CO₂ as extinguishing media.
- (4) Use safety glasses and impervious gloves when handling.
- (5) Use respiratory hydrocarbon vapor canister in enclosed areas.
- (6) Use only if adequate ventilation is available.
- (7) Avoid contact with eyes, skin, and clothing.

A5.2.2.3 *Degreasing Solvent:*

- (1) Combustible vapor harmful if inhaled.
- (2) Keep away from heat, sparks, and open flame.
- (3) Use with adequate ventilation.
- (4) Avoid breathing vapor or spray mist.
- (5) Use water spray, dry chemical, foam, or CO₂ as extinguishing media.
- (6) Avoid prolonged or repeated contact with skin.

A5.2.2.4 *Cooling System Cleanser:*

- (1) Store at moderate temperatures. Keep container closed until used.
- (2) Use water spray, dry chemical, foam, or CO₂ as extinguishing media.
- (3) Use safety glasses and impervious gloves when handling.
- (4) Use respiratory protection in absence of proper environmental control.
- (5) Use only if adequate ventilation is available.
- (6) Avoid contact with eyes, skin, and clothing.

A5.2.2.5 *Oxalic Acid (Cooling System Cleanser):*

- (1) Toxic substance. Avoid contact with eyes, skin, and clothing.
- (2) Do not inhale dust.
- (3) Keep away from feed or food products.

A5.2.2.6 *New and Used Oil Samples:*

- (1) Store at moderate temperatures and keep away from extreme heat, sparks, open flame, and oxidizing agents.
- (2) Use dry chemical, foam, or CO₂ as extinguishing media.
- (3) Use safety glasses and impervious gloves when handling.
- (4) Avoid contact with eyes, skin, and clothing.

A5.2.2.7 *Used Oil Samples Only*—Since used oils contain compounds that were not originally present in the new oil, stringently follows the Materials Safety Data Sheet's guidelines for all components present.

NOTE A5.1: In addition to other precautions, note that continuous contact with used automotive engine oils has caused skin cancer in laboratory mice.

A6. SEQUENCE VID TEST REPORT FORMS AND DATA DICTIONARY

NOTE A6.1—The actual report forms and data dictionary must be downloaded separately from the ASTM TMC Web Page at <http://www.astmtmc.cmu.edu/>, or they can be obtained in hardcopy format from the TMC.

A7. Statistical Equations for Mean and Standard Deviation

A7.1 Equations

$$\text{mean} = \frac{1}{n} \sum_{i=1}^n [Y_i(\text{standard}) - Z_i(\text{reading})] \quad (\text{A7.1})$$

$$\text{standard deviation} = \sqrt{\frac{\sum_{i=1}^n [(Y_i - Z_i) - \text{mean}]^2}{df}} \quad (\text{A7.2})$$

where:

N = total number of data pairs, and
 df = degrees of freedom = $n - 1$.

A8.1 Determining the Oil Sump Full Level

A8.1.1 Verify engine orientation on the test stand:

A8.1.1.1 Side to side engine mounting ($0.0 \pm 0.5^\circ$),

A8.1.1.2 Engine flywheel friction faceplate ($3.0 \pm 0.5^\circ$), and

A8.1.1.3 Driveline angle not less than 1.0° or greater than 2.0° in the vertical.

A8.1.2 Charge the engine with 5.4 L (5.71 qt) of BL oil.

A8.1.3 Start the engine and bring to stage Flush 1500 rpm, 70 Nm, 109 °C coolant in, 115 °C Oil conditions. Stabilize for 15 min.

A8.1.4 Shut engine down.

A8.1.5 Remove the oil from the engine using the scavenge pump.

A8.1.6 Disconnect all lines from the oil pan and allow to gravity drain.

A8.1.7 Connect the complete external oil system, including the engine oil filter, in series and in the same direction as normal oil flow. Use extra lines if needed to connect the engine oil filter into the complete system.

A8.1.8 Set the 3-way control valve (TCV-144) so that 100 % of the flow is through the heat exchanger (HX-60).

A8.1.9 Connect and purge air through the external oil flush system (step 7) using a minimum of 20 psi. (**Warning**—Recirculation oil pump shaft shall be locked to avoid damage.)

A8.1.10 Flow air through the external oil flush system (step 7) until most of the oil has been purged from the system.

A8.1.11 Cycle the 3-way control valve (TCV-144) a few times to ensure oil is purged from the bypass section of the heat exchanger (HX-6).

A8.1.12 Disconnect air supply.

A8.1.13 Connect degreasing solvent flush system to the external oil flush system (step 7).

A8.1.14 Circulate degreasing solvent (minimum of 8 L) through the external oil flush system (step 7) for a minimum of 30 min.

A8.1.15 Cycle the 3-way control valve (TCV-144) a few times to ensure oil is purged from the bypass section of the heat exchanger (HX-6).

A8.1.16 Disconnect the degreasing solvent flush system and drain the solvent from the external oil flush system.

A8.1.17 Connect and purge air through the external oil flush system (step 7) for minimum of 1 h using a minimum of 20 psi. Set the 3-way control valve (TCV-144) so that 100 % of the flow is through the heat exchanger (HX-6) for most of the hour. Cycle the 3-way control valve (TCV-144) a few times during the hour to ensure the degreasing solvent has been flushed from the bypass section of the heat exchanger (HX-6).

A8.1.18 Individually check, and purge with air if necessary, the heat exchanger (HX-6), oil heater, circulating oil pump, and oil filters to ensure all the degreasing solvent has been removed.

A8.1.19 Measure 5.4 L (5.71 qt) of BL oil and pour into engine.

A8.1.20 Start engine and ramp to Flush conditions.

A8.1.21 Once stabilized at the above conditions, mark the level on the sight glass (Fig. A2.24) and consider this as the Oil Sump Full Level.

A8.2 Oil Pan Sight Glass Calibration

A.8.2.1 With the proper full mark established on the oil pan sight glass tube and the engine running at flush conditions drain 200 mL of oil from the engine at the outlet (top) of the oil heater. Allow a few minutes for system to stabilize then mark sight glass (-200 mL).

A.8.2.2 Repeat above in increments of 200 mL until a total of 1400 mL has been removed from engine. Mark the sight glass in increments of 200 mL. Any additional marks below the 1400 mL are optional.

A.8.2.3 Return the 1400 mL of oil with engine running at **Flush** conditions, allow the system to stabilize a few minutes. The oil level should now be at the original full mark on the sight glass. Repeat the calibration procedure if the level does not return to the original sight glass full mark.

A.8.2.4 Determine the oil level in the oil pan using a level made of Tygon tubing filled with water. Use the full mark on the oil sight glass as the reference point.

A.8.2.5 Mark the oil level on the outside of the oil pan with a paint marker.

A.8.2.6 The paint mark on the oil pan shall be approximately located above the oil pump inlet fitting and lined up with the center of the oil pan tab. This tab is approximately 100 mm from the top sight glass fitting and toward the front of the engine.

A.8.2.7 Measure the distance from the bottom surface of the oil pan tab to the paint mark. This is the engine oil full level measurement. This measurement shall be 77 ± 5 mm.

A9. FUEL INJECTOR EVALUATION

A9.1 Fuel Injector Test Rig—A suitable device capable of accurate, repeatable flow measurement of port fuel injectors is required. This device shall be capable of performing necessary port fuel injector evaluations as outlined in A9.2. Since no suitable commercially available apparatus has been identified, design of the test rig is up to the laboratory. Flow test the injectors using degreasing solvent as the test fluid.

A9.2 Fuel Injectors—Prior to engine installation, evaluate all injectors (new and used) for spray pattern and flow-rate using the test rig in A9.1. Injectors may be cleaned and reused if the criteria outlined in this procedure are satisfied.

A9.2.1 Perform a visual inspection of each injector to ensure that each injector has been cleaned of all oily deposits.

A9.2.2 Check the injector “O” ring for cracking or tearing and replace as required.

A9.2.3 Flush new injectors for 30 s to remove any assembly residue before flow testing.

A9.2.4 Place the injector(s) in the test rig and turn the test fluid on. Verify the flow of test fluid through the injector(s). Maintain the test fluid pressure supplied to the injector(s) at 290 ± 3.4 kPa during the entire test. The maintenance of this pressure is critical as a small change in pressure will have a dramatic effect on the flow rate and spray pattern. Once pressure is set, zero the volume measuring device.

A9.2.5 Flow test each injector for a 60-s period. While the injector is flowing, make a visual observation of the spray pattern quality. The spray pattern shall be typical for the make and model of the injector.

A9.2.6 The set of injectors for an engine shall have a flow rate within 5 mL of each other. Discard any injector that does not flow within this range.

A9.2.7 At completion of the 60-s period, close the injector and maintain the test fluid pressure for a minimum of 30 s. Discard any injector that leaks or drips.

A10. PRE-TEST MAINTENANCE CHECKLIST

TABLE A10.1 Pre-test Maintenance Checklist

Required Maintenance	Prior to Each Test Start	Prior to Each Reference Start ^A	As Noted
Replace spark plugs			<i>C</i>
Service racor filters	X		
Verify injector flows		X	
Clean/recondition throttle BLdy			<i>B</i>
Clean coolant heat exchanger			<i>C</i>
Clean / flush oil heat exchanger			<i>B</i>
Replace fuel filters		X	
Inspect / service driveline		X	
Rotate dyno trunion bearings			<i>D</i>
Clean / replace EBP probe			<i>D</i>

^A Only required on initial reference in a series.

^B With installation of new engine.

^C As required by normal laboratory practice.

^D Every six months.

A11. BLOW-BY VENTILATION SYSTEM REQUIREMENTS

A11.1 NPT cross fitting, 3/8-in.

A11.2 NPT pipe nipple (three), 3/8-in., used to connect the 12.7 mm (½-in.) I.D. or 15.8mm (5/8-in.) I.D. hose to the 3/8-in NPT cross fitting.

A11.3 OHT6D-013-1 Dummy PCV fitting installed in the right side of the rocker cover.

A11.4 Left rocker cover shall use the original 45° fitting supplied with the engine.

A11.5 Right rocker cover shall have 304.8 ± 127mm (12 ± 5 in.) of 12.7 mm (½-in.) I.D. or 15.8mm (5/8-in.) I.D. hose to the 3/8-in. NPT cross fitting.

A11.6 Left rocker cover shall have 304.8mm ± mm (12 ± 5 in.) of 12.7mm (½-in.) I.D. or 15.8mm (5/8-in.) I.D. hose to the required cross fitting.

A11.7 Monitor crankcase pressure at the top of the 3/8-in. NPT cross fitting.

APPENDIX
(Non-mandatory Information)

X1. PROCUREMENT OF TEST MATERIALS

TBD

INTRODUCTION

Throughout the text, references are made to necessary hardware, reagents, materials, and apparatus. In many cases, for the sake of uniformity and ease of acquisition, certain suppliers are named. If substitutions are deemed appropriate for the specified suppliers, permission in writing must be obtained from the TMC before such will be considered to be equivalent. The following entries for this appendix represent a consolidated listing of the ordering information necessary to complete the references found in the text.

X1.1 General Communications Concerning Sequence VID Reference Tests, Procedural Questions and Non-Reference Tests:

ASTM Test Monitoring Center
Attention: Administrator
6555 Penn Avenue
Pittsburgh, PA 15206-4489
Telephone: (412) 365-1005

X1.2 Reference Oils and Calibration Oils:

Purchase reference oils and calibration oils by contacting:
ASTM Test Monitoring Center
Attention: Operations Manager
6555 Penn Avenue
Pittsburgh, PA 15206-4489
Telephone: (412) 365-1010

X1.3 Test Engines:

Sequence VID engines, part No. OHT6D-XXX
OH Technologies, Inc.
9300 Progress Parkway
P.O. Box 5039
Mentor, OH 44061-5039
Telephone: (440) 354-7007
Fax (440) 354-7080

X1.4 Dynamometer:

A Midwest Model 758 (50-hp) dry gap dynamometer may be ordered from:
Midwest Dynamometer Engineering Company
3100 River Road
River Grove, IL 60171
Telephone: (708) 453-5156

Fax: (708) 453-5171

X1.5 Dynamometer Load Cell:

The recommended load cell is a Lebow Model 3397 which may be ordered from:

Eaton Corporation

Lebow Products

1728 Maplelawn Road

P.O. Box 1089

Troy, MI 48099

Telephone: (313) 643-0220

Fax: (313) 643-0259

X1.6 Cooling System Pressure Cap:

A satisfactory coolant system pressure cap (70 kPa, normally closed cap) is available through local distributors.

X1.7 Cooling System Pump (P-1):

The specified cooling system pump may be obtained from:

Gould Pumps, Inc.

240 Fall Street

Seneca Falls, NY 13148

X1.8 Coolant Heat Exchanger (HX-1):

ITT (Model 320-20)

ITT Standard

175 Standard Parkway

Buffalo, NY 14227

or

Bell & Gossett (BP 75H-20 or BP 420-20)

Bell & Gossett ITT

8200 N. Austin Avenue

Morton Grove, IL 60053

X1.9 Coolant Orifice Plate (Differential Pressure):

Flowell

8308 South Regency Drive

Tulsa, OK 74131

Telephone: (918) 224-6969

X1.10 Coolant Control Valves (TCV-104, FCV-103 and TCV-101):

Badger Meter, Inc.

P.O. Box 581390

Tulsa, OK 74158

Telephone: (918) 836-8411

X1.11 Differential Pressure Transducer (DPT-1):

The recommended transducers are Viatran Model 274 or Model 374, Validyne Model DP15, and Rosemount model 1151 which may be ordered from:

Viatran Corp.

300 Industrial Drive

Grand Island, NY 14072

Telephone:(716) 773-1700

or

Validyne Engineering Corp.

8626 Wilbur Ave.

Northridge, CA 91324

Telephone:(818) 886-2057

or

Rosemount Inc.

4001 Greenbriar Street 150B

Stafford, Texas 77477

Telephone:1-800 999-9307

X1.12 Water Pump Plate:

The water pump block off plate may be purchased from:

OH Technologies, Inc.

9300 Progress Parkway

P.O. Box 5039

Mentor, OH 44061-5039

Telephone: (440) 354-7007

Fax (440) 354-7080

X1.13 Oil Scavenge Pump (P-3):

Houdaille Industries, Inc.

Viking Pump Division

George and Wyeth Street

Cedar Falls, IA 50613

Telephone: (319) 266-1741

X1.14 Thermocouples:

www.omegw.com

Telephone: (888) 826-6342

X1.15 Oil Circulation Pump (P-4):

Houdaille Industries, Inc.

Viking Pump Division

George and Wyeth Street

Cedar Falls, IA 50613

Telephone: (319) 266-1741

X1.16 External Oil System Solenoid Valves (FCV-150A, FCV-150C, FCV-150D, FCV-150E and FCV-150F):

Burkert Contromatic Corp.
1091 N. Batavia Street
Orange, CA 92667
Telephone: (714) 744-3230
Fax: (714) 639-4998

X1.17 External Oil System Control Valves (TCV-144 and TCV-145):

Badger Meter, Inc.
P.O. Box 581390
Tulsa, OK 74158
Telephone: (918) 836-8411

X1.18 Oil Heat Exchanger (HX-6):

ITT (Model 310-20):

ITT Standard
175 Standard Parkway
Buffalo, NY 14227

or

Bell & Gossett (Model BP 25-20 or BP 410-020):

Bell & Gossett ITT
8200 N. Austin Avenue
Morton Grove, IL 60053

X1.19 Electric Oil Heater Housing (EH-5):

TEST ENGINEERING, INC. (TEI)

12718 Cimarron Path
San Antonio, TX 78249
Telephone: (210) 690-1958
Fax: (210) 690-1959

X1.20 Oil Filter Housing Assembly and Filters (Screen) (FIL-2):

Racor:
PO Box 3108
Modesto, CA 95353
Telephone: (800) 344-3286

X1.21 Modified Oil Filter Adapter Assembly:

OH Technologies, Inc.
9300 Progress Parkway
P.O. Box 5039
Mentor, OH 44061-5039
Telephone: (440) 354-7007
Fax: (440) 354-7080

X1.22 External Oil System Hose and Quick Disconnect Fittings:

Aeroquip products are available through local distributors or:
Aeroquip Corporation
Industrial Division
1225 W. Main Street
Van Wert, OH 45891
Telephone: (419) 238-1190

X1.23 Modified Oil Pan and Modified Oil Pick-Up Tube:
The oil pan and oil level blocking plate may be purchased from:
OH Technologies, Inc.
9300 Progress Parkway
P.O. Box 5039
Mentor, OH 44061-5039
Telephone: (440) 354-7007
Fax: (440) 354-7080

X1.24 Fuel Flow Measurement Mass Flow Meter:
MicroMotion, Inc.
7070 Winchester Circle
Boulder, CO 80301
Telephone: (303) 530-8400 or (800) 522-6277
Fax: (303) 530-8209

X1.25 AFR Analyzer:
The recommended AFR analyzer is a Horiba MEXA 700 which may be ordered from:
Horiba Instruments, Inc.
17671 Armstrong
Irvine Industrial Complex
Irvine, CA 92623
Telephone: (714) 250-4811

X1.26 ECM (Engine Control Module):
OH Technologies Inc.
9300 Progress Parkway
P.O. Box 5039
Mentor, OH 44061-5039
Telephone: (440) 354-7007
Fax: (440) 354-7080

X1.27 Engine Wiring Harness Without Interface:
OH Technologies Inc.
9300 Progress Parkway
P.O. Box 5039
Mentor, OH 44061-5039
Telephone: (440) 354-7007
Fax: (440) 354-7080

X1.28 Modified Coolant Inlet (Oil Filter Adapter):

The coolant inlet adapter may be purchased from:

OH Technologies Inc.

9300 Progress Parkway

P.O. Box 5039

Mentor, OH 44061-5039

Telephone: (440) 354-7007

Fax: (440) 354-7080

X1.29 Organic Solvent (Penmul L460):

Penetone Corporation

74 Hudson Avenue

Tenafly, NJ 07670

X1.30 Degreasing Solvent:

Available from local suppliers.

X1.31 Damper drivelines may be purchased from:

Machine Service Inc. – <http://www.machineservice.com/contact.htm>

American VULKAN Corporation - 2525 Dundee Road, Winterhaven, FL 33884 (863)-324-2424

X1.32 Engine Mounts:

OH Technologies Inc.

9300 Progress Parkway

P.O. Box 5039

Mentor, OH 44061-5039

Telephone: (440) 354-7007

Fax: (440) 354-7080

X1.33 Test Fuel:

Haltermann Products

1201 Sheldon Road,

P.O. Box 429

Channelview, TX

77530-0429.

X1.34 Order parts specified as “available from CPD” from:
OH Technologies Inc.
9300 Progress Parkway
P.O. Box 5039
Mentor, OH 44061-5039
Telephone: (440) 354-7007
Fax: (440) 354-7080

X1.35 Paxton Fuel Pressure Regulator
Can be obtained from Summit Racing
960 East Glendale Avenue
Sparks, NV 89431
www.summitracing.com

Annex C

Data Summary

LAB CODE	LAB STAND #	TEST COMPLETION DATE	ENGINE #	INDUSTRY OIL CODE	FEI1 RESULT	FEI2 RESULT	ENGINE HRS. AT COMPLETION
G	1	20090119	13A	GF5A	1.9	1.36	486
G	1	20090302	13A	GF5A	1.04	1.31	1428
G	2	20090302	8A	GF5A	1.42	1.05	1599
G	1	20090324	13A	GF5A	1.29	0.95	1901
A	1	20090325	10B	GF5A	1.47	1.07	1716
D	1	20090326	13B	GF5A	1.3	0.89	952
G	2	20090331	8A	GF5A	1.11	1.2	2237
D	2	20090402	10A	GF5A	1.04	0.82	2309
B	1	20090405	3A	GF5A	1.16	1	1406
A	2	20090408	6B	GF5A	1.46	0.82	3029
F	1	20090410	11A	GF5A	1.25	0.95	2971
G	2	20090126	8A	GF5B	1.26	0.5	810
G	2	20090309	8A	GF5B	0.94	0.79	1766
A	1	20090310	10B	GF5B	1.03	1.07	1407
G	2	20090223	8A	GF5C	1.16	0.34	1441
G	1	20090223	13A	GF5C	1.16	0.63	1271
A	1	20090224	10B	GF5C	1.71	1.2	1100
A	2	20090224	6B	GF5C	1.51	0.78	2102
A	2	20090119	6B	GF5D	1.13	1.01	1315
G	1	20090309	13A	GF5D	0.81	0.62	1585
B	1	20090312	3A	GF5D	0.83	0.54	1058
G	2	20090317	8A	GF5D	0.62	0.73	1923
G	1	20090317	13A	GF5D	0.96	0.84	1744
A	1	20090318	10B	GF5D	1.28	0.98	1563
A	2	20090318	6B	GF5D	0.97	0.77	2567
D	2	20090318	10A	GF5D	0.57	0.43	1969
D	1	20090319	13B	GF5D	0.96	0.85	793.2
A	2	20090325	6B	GF5D	1.08	0.66	2722
F	1	20090326	11A	GF5D	0.85	0.64	2614

Annex D
Statistical Data Summary