

Sequence IX Draft, [April 2018 TWB](#)
(Based on document "Seq IX LSPI Test Method_20180412.docx")

Date: April 30, 2018

To: Subcommittee D02.B0 members

Technical Contact: Terry Bates, batesterryw@aol.com

Work Item #: 54716

Ballot Action: New engine oil test method

Rationale: This new test method will likely be in the new ILSAC GF-6 engine oil specification

Prepared by Terry Bates

Standard Test Method for Evaluation of Performance of Automotive Engine Oils in the Mitigation of Low-Speed, Preignition in the Sequence IX Gasoline Turbocharged Direct-Injection, Spark-Ignition Engine

This standard is issued under the fixed designation X XXXX; the number immediately following the designation indicates the year of original adoption or, in the case of revision, the year of last revision. A number in parentheses indicates the year of last reapproval. A superscript epsilon (ϵ) indicates an editorial change since the last revision or reapproval.

INTRODUCTION

Portions of this test method are written for use by laboratories that make use of ASTM Test Monitoring Center (TMC)^{1,2} services (see Annexes A1 to A4).

The TMC provides reference oils, and engineering and statistical services to laboratories that desire to produce test results that are statistically similar to those produced by laboratories previously calibrated by the TMC.

In general, the test purchaser decides if a calibrated test stand is to be used. Organizations such as the American Chemistry Council require that a laboratory utilize the TMC services as

¹ ASTM Test Monitoring Center, 6555 Penn Avenue, Pittsburgh, PA 15206-4489. www.astmtmc.cmu.edu.

² Until the next revision of this test method, the ASTM TMC will update changes to this method by means of Information Letters. Information Letters may be obtained from the TMC.

Sequence IX Draft, [April 2018 TWB](#)
(Based on document “Seq IX LSPI Test Method_20180412.docx”)

part of their test registration process. In addition, the American Petroleum Institute and the Gear Lubricant Review Committee of the Lubricant Review Institute (SAE International) require that a laboratory use the TMC services in seeking qualification of oils against their specifications.

The advantage of using the TMC services to calibrate test stands is that the test laboratory (and hence the Test Purchaser) has an assurance that the test stand was operating at the proper level of test severity. It should also be borne in mind that results obtained in a non-calibrated test stand may not be the same as those obtained in a test stand participating in the ASTM TMC services process.

Laboratories that choose not to use the TMC services may simply disregard these portions.

1. Scope

1.1 This laboratory engine test evaluates the ability of an automotive engine to mitigate preignition in the combustion chambers in gasoline, turbocharged, direct-injection (GTGI) engines under low-speed and high-load operating conditions. This test method is commonly known as the Ford low-speed, preignition (LSPI) test.

1.1.1 In vehicles, equipped with relatively small gasoline GTDI spark-ignition engines, preignition has occasionally occurred when the vehicles are operated under low-speed and high-load conditions. Uncontrolled, preignition may cause destructive engine damage.

1.2 The values stated in SI units are to be regarded as standard. No other units of measurement are included in this standard.

1.2.1 *Exceptions*—Where there is no direct SI equivalent such as screw threads, national pipe threads/diameters, tubing size, wire gage, or specified single source equipment.

1.3 *This standard does not purport to address all of the safety concerns, if any, associated with its use. It is the responsibility of the user of this standard to establish appropriate safety and health practices and determine the applicability of regulatory limitations prior to use.*

2. Referenced Documents

2.1 ASTM Standards³:

D86 Test Method for Distillation of Petroleum Products and Liquid Fuels at Atmospheric Pressure

³ For referenced ASTM standards, visit the ASTM website, www.astm.org, or contact ASTM Customer Service at service@astm.org. For *Annual Book of ASTM Standards* volume information, refer to the standard's Document Summary page on the ASTM website.

Sequence IX Draft, [April 2018 TWB](#)
(Based on document “Seq IX LSPI Test Method_20180412.docx”)

D130 Test Method for Corrosiveness to Copper from Petroleum Products by Copper Strip Test

D235 Specification for Mineral Spirits (Petroleum Spirits) (Hydrocarbon Dry Cleaning Solvent)

D323 Test Method for Vapor Pressure of Petroleum Products (Reid Method)

D525 Test Method for Oxidation Stability of Gasoline (Induction Period Method)

D381 Test Method for Gum Content in Fuels by Jet Evaporation

D1298 Test Method for Density, Relative Density, or API Gravity of Crude Petroleum and Liquid Petroleum Products by Hydrometer Method

D1319 Test Method for Hydrocarbon Types in Liquid Petroleum Products by Fluorescent Indicator Adsorption

D2622 Test Method for Sulfur in Petroleum Products by Wavelength Dispersive X-ray Fluorescence Spectrometry

D2699 Test Method for Research Octane Number of Spark-Ignition Engines

D2700 Test Method for Motor Octane Number of Spark-Ignition Engine Fuel

D2709 Test Method for Water and Sediment in Middle Distillate Fuels by Centrifuge

D3120 Test Method for Trace Quantities of Sulfur in Light Liquid Petroleum Hydrocarbons by Oxidative Microcoulometry

D3231 Test Method for Lead in Gasoline by Atomic Absorption Spectroscopy

D3237 Test Method for Lead in Gasoline by Atomic Absorption Spectroscopy

D4175 Terminology Relating to Petroleum, Petroleum Products, and Lubricants

D5453 Test Method for Determination of Total Sulfur in Light Hydrocarbons, Spark Ignition Engine Fuel, Diesel Engine Fuel, and Engine Oil by Ultraviolet Fluorescence

2.2 American National Standards Institute Standards⁴

ANSI MC96.1 Temperature Measurement-Thermocouples

3 Terminology

3.1 Definitions:

3.1.1 *engine oil, n*—a liquid that reduces friction or wear, or both, between the moving parts within an engine; removes heat, particularly from the underside of pistons; and serves as a combustion gas sealant for piston rings.

⁴ Available from ANSI, 1899 L Street, NW, 11th Floor, Washington, DC 20036. Tel: +1 202 293 89020; www.ansi.org.

Sequence IX Draft, [April 2018 TWB](#)
(Based on document “Seq IX LSPI Test Method_20180412.docx”)

3.1.1.1 *Discussion*—It may contain additives to enhance certain properties. Inhibition of engine rusting, deposit formation, valve train wear, oil oxidation, and foaming are examples.

D4175

3.1.2 *lubricant test monitoring system (LTMS)*, *n*—an analytical system in which ASTM calibration test data are used to manage test precision and severity (bias). **D4175**

3.1.2 *preignition*, *n*—*in a spark-ignition engine*, ignition of the mixture of fuel and air in the combustion chamber before the passage of the spark. **D4175**

3.2 *Definitions of Terms Specific to This Standard:*

3.2.1 *PCM*, *n*—an engine control unit, most commonly called the powertrain control module (PCM), is an electronic device that instantaneously controls a series of actuators on an internal combustion engine to ensure optimal engine performance.

3.4 *Acronyms and Abbreviations*

3.4.1 AvPIE—average preignition events

3.4.2 CAN—controller area network

3.4.3 DAC—digital-to-analog converter

3.4.4 DACA—data acquisition and control automation

3.4.5 e_i —prediction error

3.4.6 ECU—electronic control unit

3.4.7 EEC—Electronic Engine Control

3.4.8 GTDI—gasoline turbocharged direct injection

3.4.9 IBP—initial boiling point

3.4.10 ID—internal diameter

3.4.11 KP_INT—knock interval

3.4.12 LCR—lower compression ring

3.4.13 LTMS—lubricant test monitoring system

3.4.14 LSPI—low speed preignition

3.4.15 MAF—mass air flow

3.4.16 MAP—manifold absolute pressure

3.4.17 MAPT—manifold absolute pressure and temperature

Sequence IX Draft, [April 2018 TWB](#)
(Based on document “Seq IX LSPI Test Method_20180412.docx”)

- 3.4.18 MFB—mass fraction burn
- 3.4.19 MFB2—mass fraction burn at 2 %
- 3.4.20 PCM—powertrain control module
- 3.4.21 PCV—positive crankcase ventilation
- 3.4.22 PID —parameter identification
- 3.4.23 PMAX—maximum pressure
- 3.4.24 PMAXV—pressure maximum voltage
- 3.4.25 PMINV—pressure minimum voltage
- 3.4.26 PP—peak pressure
- 3.4.27 P/N—part number
- 3.4.28 UCR—upper compression ring
- 3.4.29 VCT—variable valve timing
- 3.4.30 WOT—wide open throttle
- 3.4.21 Z_r —exponentially weighted moving average

4. Summary of Test Method

4.1 The test procedure is a “flush and run” test, that is the test engine is used for multiple tests and the next test oil is used to flush the previous test oil from the engine.

4.2 The test procedure is conducted in four iterations. Each iteration is 175,000 engine cycles in length.

4.3 Low-engine speed and high-load, steady-state conditions are used to generate preignition events, which are counted throughout each of the four 175,000 engine cycles.

4.4 Combustion pressure is measured directly in each cylinder to provide documentary evidence of the occurrence of preignition events.

5. Significance and Use

5.1 This test method evaluates the ability of an automotive engine to mitigate preignition in the combustion chambers in turbocharged, direct injection, gasoline engines under low-speed and high-load operating conditions.

5.2 Varying quality reference oils, with known preignition tendencies, were used in developing the operating conditions of the test procedure.

Sequence IX Draft, [April 2018 TWB](#)
(Based on document “Seq IX LSPI Test Method_20180412.docx”)

5.3 The test method has applicability in gasoline engine oil specifications and is expected to be used in specifications and classifications of engine lubricating oils, such as the following:

5.3.1 Specification D4485

5.3.2 ILSAC GF-6.

5.3.3 [Military Specification MIL-PRF-2104](#).

5.3.4 [SAE Classification J183](#).

Commented [TB1]: 1.Please confirm this is correct

6. Apparatus (General Description)

6.1 *Test Engine*—The test engine is a spark ignition, four-stroke, four-cylinder gasoline turbocharged direct injection engine with a displacement of 2.0 L. Features of this engine include variable camshaft timing, dual overhead camshafts driven by a timing chain, four valves per cylinder, and electronic direct-fuel injection. It is based on the Ford Motor Co. 2012 Explorer engine^{5,6}.

6.2 Configure the test stand to accept the test engine. All special equipment necessary for conducting this test is listed below.

6.3 Use appropriate air conditioning apparatus to control the temperature, pressure, and humidity of the inlet air to meet the requirements in [Table 6](#).

6.4 Use an appropriate fuel supply system. A typical system is shown in [Fig. 1](#).

NOTE 1—The fuel may need to be heated to maintain the fuel temperature in [Table 6](#). As a consequence, heat may buildup in the fuel system during shutdown thereby increasing the pressure in the fuel lines. It is good practice, therefore, to include a pressure relief valve in the fuel line to relieve the pressure and to send the excess fuel back to the tank before the shutoff valve.

6.5 The control and data acquisition system shall meet the requirements listed in [Annex A5](#).

6.6. *Engine Cooling System:*

6.6.1 Use the coolant inlet and outlet system from OH Technologies^{7,66}. Typical plumbing for the external coolant system is shown in [Figs. A6.2 and A6.3](#). Use a coolant flow meter with an accuracy of $\pm 1\%$. Install the flowmeter at either the coolant inlet or coolant outlet sides of the engine. Install the flow control valve in the line running from the engine coolant outlet to the heat

Formatted: Footnote Reference, Font: 10 pt, Not Superscript/ Subscript

⁵ The sole source of supply of this component known to the committee at this time is Ford Motor Co., 290 Town Center Dr, Dearborn, MI 48126.

⁶ If you are aware of alternative suppliers, please provide the information to ASTM International Headquarters. Your comments will receive careful consideration at a meeting of the responsible technical committee which you may attend.

⁷ The sole source of supply of this part known to the committee at this time is OH Technologies, 9300 Progress Pkwy., Mentor, O 44060, USA.. Tel: +1 440 354 7007. www.ohtech.com.

Sequence IX Draft, [April 2018 TWB](#)
(Based on document “Seq IX LSPI Test Method_20180412.docx”)

exchanger. ITT standard heat exchangers^{8,66} have been found suitable. Use 38 mm (1.5 in.) pipe to plumb the coolant system. Minimize the number of elbows in the cooling system. Ensure that the engine coolant flows through the tube side of the heat exchanger.

Formatted: Footnote Reference, Font: 10 pt, Not Superscript/ Subscript

6.6.2 A radiator cap (Motorcraft RS40 P/N D2YY-8100-A⁹) is used to limit system pressure to 105 kPa. Pressurize the coolant system to 70 kPa ± 10 kPa at the top of the coolant reservoir.

6.6.3 Control the engine-coolant flow rate and outlet temperature to meet the requirements in [Table 6](#).

6.6.4. Inspect engine coolant components external to the engine every three months and clean as necessary.

6.7 *Oil System Components*—All oil system components in the engine are production configuration with the exception of the modified oil pan ([Fig. A6.1](#)) and oil filter housing ([Fig. A6.12](#)).

6.8 Using the production oil cooler, control the oil temperature by running process water through the water-side of the oil cooler. Locations of oil-temperature thermocouples are shown in [Fig. A6.12](#).

6.9 *Dynamometer*—Use Midwest dynamometer model MW-1014A¹⁰ available from OHT¹².
Error! Bookmark not defined.

Formatted: Footnote Reference, Font: 10 pt

6.10 *Combustion Analysis Equipment*—Use the AVL IndiSmart GigaBit 612 combustion analysis system and the AVL IndiCom combustion analysis software^{11,66}. For the latter, use the amplifier and pressure settings and the standard results settings given in [A11.1.1](#) and [A11.1.2](#), respectively. Report the channels shown in [A11.3](#).

Formatted: Footnote Reference, Font: 10 pt, Not Superscript/ Subscript

⁸ The sole source of supply of this part known to the committee at this time is Kinetics Engineering Corp., 2055 Silber Road, Suite 101, Houston, TX 77055.

⁹ Available from Ford dealership as well as select auto parts stores.

¹⁰ Available from Dyne Systems, Inc. W209 N17391 Industrial Drive, Jackson, WI 53037 USA 800-657-0726; dtnesystems.com and from Dyno One, Inc. 14671 N 250 W Edinburg, IN 46124, info@dyno-one.com. Tel 812-526-0500.

¹¹ The sole source of supply of this system is AVL Gmbh, Platz 1, A-8020, Graz, Austria. www.avl.com.

Sequence IX Draft, [April 2018 TWB](#)
 (Based on document “Seq IX LSPI Test Method_20180412.docx”)

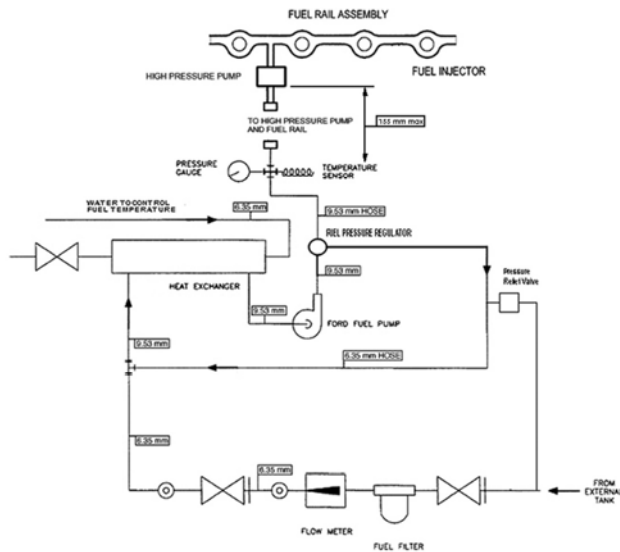

FIG. 1 Typical Fuel Supply System

6.11 Fuel and Fuel System:

6.11.1 System Description—Fig. 1 is a schematic diagram of a typical fuel supply system. Supply an excess volume of fuel to the high-pressure fuel pump and fuel rail at all times. Introduce make-up fuel (that is, fuel used by the engine) into the loop from an external source. Mix the make-up fuel with fuel that is returned from the fuel rail (that is, fuel not used by the engine). Pump the fuel through a mixing chamber, or a small heat exchanger, to mix the two streams and to provide fuel of consistent temperature to the engine. Deliver the fuel to a high-pressure pump (Ford P/N AG9Z-9350-B/AG9E-9D376-AB^{12,66} that boosts the pressure and supplies the fuel to the fuel rail.

6.11.2 Controls—Maintain the fuel temperature to the high-pressure pump at 30 °C ± 0.5 °C. To ensure good atomization of the fuel, maintain the fuel pressure to the high-pressure pump above 450 kPa ± 37 kPa. Maintain constant fuel pressure throughout the test to ensure good speed, power, and air-fuel ratio control.

6.11.3 Test Fuel—Approximately 340 L of Haltermann HF003 Lube Certification fuel^{12,66} are required for each test. (Warning—Flammable, health hazard.) A list approved suppliers is listed in X.X.

Formatted: Footnote Reference, Font: 10 pt
 Formatted: Footnote Reference, Font: 10 pt, Not Superscript/ Subscript

Formatted: Footnote Reference, Font: 10 pt, Not Superscript/ Subscript
 Commented [FM2]: 2.Add list of approved suppliers, and reference it here.
 3.Add wording about potential suppliers.

¹² The sole source of supply of this fuel known to the committee at this time is Haltermann Products, 1201 Sheldon Road, P.O. Box 429, Channeview, TX 777530, USA. www.haltermansolutions.com.

6.11.4 *Fuel Batch*—Ensure each new batch of fuel is accompanied by a certificate of analysis showing that it meets the requirements shown in Table A7.1.

Commented [FM3]: 4.recommend field created and capturing on report

6.11.4.1 Fuel from a new batch can be added to a laboratory's fuel tank at anytime provided it meets the requirements in Table A7.1 – see also 6.11.4.2.

~~6.11.4.2 *Fuel Batch Analysis*—Fuel Batch Analysis—It is the responsibility of the laboratory to analyze a fuel sample every 30 days to verify the value of several key parameters identified in Table A7.1 with an asterisk. The results shall be within the specification band shown in Table A7.1. This comparison will indicate if the fuel batch is contaminated or has aged prematurely. If any results fall outside the tolerances shown in Table A7.1, the laboratory shall contact the TMC and the supplier to determine the suitability of using that batch for this engine test. Upon receipt from the supplier, it is the responsibility of the laboratory to analyze each fuel shipment to determine the value of the parameters shown in Table A7.1. Compare the results to the values provided by the supplier on that particular batch. The results shall be within the specification band shown in Table A7.1. This comparison will indicate if the fuel batch is contaminated or has aged prematurely. If any results fall outside the tolerances shown in Table A7.1, the laboratory shall contact the TMC and the supplier for help in resolving the problem. Reviewing an analysis of the as received fuel sample, taken at the fuel supplier's laboratory prior to shipment, could be helpful.~~

Commented [FM4]: 5.what analysis needs to be done by lab on fuel to validate purity/quality (every CoA measure is not practical), 6.11.4.2, recommend Sulfur, Gums, vapor press, distillation

Commented [FM5R4]: 6.George to make a draft requirement to replace this paragraph.

7. Apparatus (The Test Engine)

7.1 *Sequence IX Test Engine*—The test engine parts are available from the Ford Motor Company⁵⁵⁶. A detailed listing of all parts and P/Ns is given in Annex A8.

Formatted: Footnote Reference, Font: 10 pt

7.2 *Required New Engine Parts*—A new short-block is required when initially referencing a stand and engine combination. This short-block can be re-used provided it remains within service limits and is capable of being referenced. New crush washers and gaskets are required whenever the engine/short-block is disassembled (for example, for pretest measurements or repair). New camshafts and buckets are required when first building a cylinder head. New valves are required when rebuilding a cylinder head.

Formatted: Footnote Reference, Font: 10 pt, Not Superscript/ Subscript

7.3 *Reusable Engine Parts*—The cylinder head can be used on subsequent short-blocks as long as it remains within the service limits in the workshop manual. The parts listed in Tables A8.2, A8.6, and A8.7 can be used for multiple tests as long as they are in good condition and meet the service limits in the workshop manual.

7.4 *Specially Fabricated Engine Parts*—The following subsections detail the specially fabricated engine parts required in this test method:

7.4.1 *Inlet Air System* (see [Fig. A6.8](#))—Fabricate the inlet air system using the stock 2012 Explorer air cleaner assembly and mass air flow (MAF) sensor as detailed in Table A8.6. Install the fresh-air tube, air-cleaner assembly, and new air filter. Modify the air-cleaner assembly to accept fittings for an inlet-air-temperature thermocouple and pressure tap as shown in [Fig. A6.8](#). Either use the 2012 Explorer fresh-air tubes or fabricate fresh-air tubes so as to provide a separation of 1,040 mm ± 25 mm from the MAF sensor to the turbocharger inlet.

7.4.2 *Oil Pan*—Modify the stock 2012 Explorer oil pan to add an oil drain plug in one of the rear locations shown in [Fig. A6.1](#).

7.4.3 *Cylinder Head*—Use a modified cylinder head that allows the installation of in-cylinder pressure sensors. This engine part is available from TEI^{13,66}.

7.4.4 *Pressure Sensor Tubes*—Install 3/8 in. OD steel tubing into the pressure sensor sleeves in the cylinder head to allow for installation of the in-cylinder pressure sensors.

7.4.5 *Valve Cover*—Modify the stock valve cover to allow the pressure sensor tubes to protrude through the cover. Seal the location where the tubes protrude through the cover to prevent oil from leaking through the penetrations.

7.4.6 *Coolant Supply Manifold*—To accept the coolant-in thermocouple ([Fig. A6.2](#)), use a coolant-inlet purchased from OH Technologies^{72,66} in place of the stock coolant inlet.

7.4.7 *Coolant Return Manifold*—To accept the coolant-out thermocouple and provide a coolant return from the turbocharger ([Fig. A6.2](#)), use a coolant outlet purchased from OH Technologies^{Error! Bookmark not defined.} in place of the stock thermostat housing.

7.4.8. *Oil Filter Housing*—Modify the oil-filter housing to accept a thermocouple on the front side of the housing, facilitating measurement of the oil temperature entering the oil cooler.

7.5 *Special Engine Measurement and Assembly Equipment*—For assembly, use any special tools or equipment shown in the 2012 Explorer Service Manual. Complete any assembly instructions not detailed in Section 7 according to the instructions in the 2012 Explorer Service Manual. Apparatus routinely used in a laboratory or workshop are not included.

7.5.1 *Piston Ring Positioner*—Use the piston-ring positioner to locate the piston rings down from the cylinder-block deck surface by 38 mm. This allows the compression rings to be

Commented [FM6]: 7.Update figure to show pressure sensor and TC in correct locations
TWB: PLEASE UPDATE FIG, as indicated in your comment to Fig A6.10

Formatted: Footnote Reference, Font: 10 pt, Not Superscript/ Subscript

Commented [FM7]: 8.Add o-ring p/n and valve seal.
TWB: PLEASE provide info

Formatted: Footnote Reference, Font: 10 pt

Formatted: Footnote Reference, Font: 10 pt, Not Superscript/ Subscript

Formatted: Footnote Reference, Font: 10 pt, Not Superscript/ Subscript

¹³ Test Engineering Inc., 12758 Cimmaron Path, Ste. 102, San Antonio, TX 78249-3417.

positioned in a consistent location in the cylinder bore for the ring-gap measurement. Fabricate the positioner according to the details shown in Fig. A6.13.

7.5.2 *Engine Service Tools*—A list of special tools¹⁴ for the test engine is shown in Table A8.8. The tools are designed to aid carrying out several service items, in addition to the specific service items that require special tools to perform the functions indicated (if not self-explanatory).

7.6 *Engine Installation on the Test Stand:*

7.6.1 *General*—Functions that are to be performed in a specific manner or at a specific time in the assembly process are noted here.

7.6.2 *Mounting the Engine on the Test Stand*—Mount the engine on the test stand so that the flywheel friction face is $0.0^\circ \pm 0.5^\circ$ from vertical. Use two motor mounts at the rear of the engine. Quicksilver P/N 6628-A has been found suitable for this purpose. An example of a rear-mount support is shown in Fig. A6.5. Use a rubber mount at the front of the engine attached to the front-cover mount. Examples of front-mount supports are shown in Fig. A6.4. Ensure the engine is at $0.0^\circ \pm 0.5^\circ$ roll angle.

7.6.3 *Flywheel*—Obtain the modified flywheel (P/N OHTVH-006-1) from the OH Technologies^{Error! Bookmark not defined.}. Lightly coat the flywheel bolts with Loctite 565 to prevent any oil from seeping out of the holes. Torque the flywheel to 108 N•m to 115 N•m.

Formatted: Footnote Reference, Font: 10 pt, Not Superscript/ Subscript

7.6.4 *Clutch and pressure plate*—Obtain the clutch (Sachs P/N K0047-07), the pressure plate (P/N VH006-8-2) and spacer (P/N OVTVH-011-1) from OH Technologies^{Error! Bookmark not defined.}. Put the flat side on the clutch toward the engine and put the spacer between the flywheel and pressure plate. Torque the pressure plate bolts to 25 N•m to 33 N•m. Replace the clutch and pressure plate with every new engine.

Formatted: Footnote Reference, Font: 10 pt, Not Superscript/ Subscript

7.6.5 *Driveline*—Grease the driveline every test. The driveline specifications are as follows:

- a) Driveline degree: $1.5^\circ \pm 0.5^\circ$;
- b) Installed length from flange to flange: 595 mm \pm 13 mm;
- c) 1410 series flanges;
- d) Pilot: 70 mm (2.75 in.);
- e) Bolt circle: 95 mm (3.75 in.);

¹⁴ Available from any Ford dealership or from Owatonna Tools Co., 2013 4th St., NW Owatonna, MN 55060.

Sequence IX Draft, [April 2018 TWB](#)
(Based on document "Seq IX LSPI Test Method_20180412.docx")

- f) Stub and slip: 90 mm (3.50 in.) and 2.111 mm (0.083 in.), respectively.

7.7 Exhaust System:

7.7.1 **Warning**—Exhaust gas is noxious. (Caution: Any leaks in the connections to the sample probes will result in erroneous readings and incorrect air-fuel ratio adjustment.)

7.7.2 A typical exhaust system, with fittings for backpressure probe, oxygen (O₂) sensors and thermocouple, is illustrated in [Fig. A6.6](#).

7.7.3 Construct exhaust components from either solid or bellows pipe/tubing. Other flexible pipe type is not acceptable.

7.7.4 Use the backpressure probes until they become unserviceable. If the existing probes are not cracked, brittle, or deformed, clean the outer surfaces and clear all port holes. Check the probes for possible internal obstructions and reinstall the probes in the exhaust pipe.

7.7.4.1 Stainless steel probes are generally serviceable for several tests; mild steel probes tend to become brittle after one test.

7.8 Fuel Management System:

7.8.1 *Fuel Injectors*—Inspect the O-rings to ensure they are in good condition and will not allow fuel leaks. Replace if necessary. Install the fuel injectors into the fuel rail and the cylinder head.

7.9 Powertrain Control Module:

7.9.1 Use a PCM provided by Ford Motor Company^{55,66} to run this test. The PCM contains a calibration developed for this test. The PCM calibration number is U502-HBBJ0-v1-7-VEP-371.VBF.

7.9.1.1 The PCM is powered either by a 13.5 V ± 1.5 V battery or an alternative power supply that does not interrupt/interfere with proper PCM operation.

7.9.1.2 Connect the PCM battery/power supply to the engine-wire harness with an appropriate gage wire of the shortest practical length so as to maintain a dc voltage of 12 V to 15 V and minimize PCM electrical noise problems. Ground the PCM ground wire to the engine. From the same ground point, run a minimum 2 gage wire back to the battery negative to prevent interruption/interference of the PCM operation. The power supply can also be used for the lambda (oxygen) sensors.

7.10 Spark Plugs:

Formatted: Footnote Reference, Font: 10 pt

Formatted: Footnote Reference, Font: 10 pt, Not Superscript/ Subscript

Sequence IX Draft, [April 2018 TWB](#)
(Based on document “Seq IX LSPI Test Method_20180412.docx”)

7.10.1 Use Motorcraft CYFS-12-Y2³⁰ spark plugs. Spark plugs come pre-gapped. Torque the spark plugs to 9 N·m to 12 N·m. Do not use anti-seize compounds on spark plug threads.

Formatted: Footnote Reference, Font: 10 pt

7.11 Crankcase-Ventilation System:

7.11.1 The crankcase-ventilation system is vented to the atmosphere through the port in the valve cover and is not to be connected to the inlet.

7.12 Water-to-Air Turbocharger Intercooler:

7.12.1 Use water-to-air intercooler capable of achieving the required air-charge temperatures in [Tables 3 to 6](#) and an average, system-pressure loss less than 3 kPa. Type 5 or Type 52 intercoolers from Frozenboost^{15,66} have been found suitable.

Formatted: Footnote Reference, Font: 10 pt, Not Superscript/ Subscript

When cleaning the intercooler as part of normal maintenance, spray clean the air side of the intercooler with solvent, rinse with hot water and leave to air-dry. Use commercial AquaSafe descaler to clean the water-side.

7.13 Intercooler Tubing

7.13.1 Fabricate the inlet-air system with 51 mm internal diameter (ID), stainless steel tubing from the turbocharger to the intercooler, and 64 mm ID, stainless steel tubing from the intercooler to the throttle body. The tubing length is not specified but should be the appropriate length to achieve the required air charge temperature in [Tables 3 to 6](#) and an average system pressure loss less than 3 kPa.

7.13.1.1 Locate the sensor for measuring the manifold absolute pressure and temperature (MAPT) 305 mm ± 25 mm from the intake surface of the throttle body and the intake-air-charge temperature thermocouple 25 mm (1 in.) downstream from the MAPT sensor. Place the probe for measuring the post-intercooler, turbo-boost pressure a minimum of 305 mm upstream from the MAPT sensor. Place the probe for measuring the pre-intercooler, turbo-boost pressure 155 mm ± 25 mm from the turbocharger outlet. The measurements can be seen in [Fig. A6.9](#) and typical installation is shown in [Fig. A6.10](#).

Commented [TB8]: 9. Fig A6.9 shows a measurement A + B = 155 ± 50 mm but not 155 ± 25 mm. Comment appreciated.

7.14 External Hose Replacement

7.14.1 Inspect all external hoses used on the test stand and replace any hoses that have become unserviceable. Check for internal wall separations that could cause flow restrictions. Check all connections to ensure security.

7.15 Wiring Harness

¹⁵ FrozenBoost Inc., www.frozenboost.com.

Sequence IX Draft, [April 2018 TWB](#)
 (Based on document “Seq IX LSPI Test Method_20180412.docx”)

7.15.1 There are two wiring harnesses used on the test stand - a dynamometer harness that connects to the stand power and PCM, and an engine harness. Obtain the dynamometer and engine-wiring harnesses from OH Technologies^{73,66}. Diagrams of these wire harnesses are shown in [Figs A6.16 and A6.17](#) identifying connections.

Formatted: Footnote Reference, Font: 10 pt

Formatted: Footnote Reference, Font: 10 pt, Not Superscript/ Subscript

Commented [TB9]: 10. There are no Figs for these wiring harnesses. Please supply them.

7.16 *Electronic Throttle Controller:*

7.16.1 Control the electronic-throttle controller using signals from the simulated, accelerator-pedal position. The dynamometer wiring harness is supplied with an Accelerator Pedal Position jumper cable with un-terminated pigtail leads.

7.16.1.1 Connect the two voltage command signals, Acc Pos Sensor 1 and Acc Pos Sensor 2, to the Accelerator Pedal Position jumper cable. The voltage control ranges for each signal are shown in [Table 1](#). The wiring schematic and pin-out description for this connection are shown in [Fig. 2](#).

7.6.1.2 ACC Pos Sensor 2 shall always equal 50 % of Acc Pos Sensor 1.

7.16.1.3 Run the voltage signals through a voltage isolator otherwise interference will occur between the laboratory digital-to-analog converter (DAC) system and the engine electronic control unit (ECU) leading to erratic throttle control.

TABLE 1 Accelerator Position Sensor Control Ranges

Command Signal	Operating Range, V ^A	Min Signal (Idle), V ^A	Max Signal (WOT), V ^A
Acc Pos Sensor 1	0 to 5.0	0.75 (15 %)	4.25 (85 %)
Acc Pos Sensor 2	0 to V	0.375 (15 %)	2.125 (85 %)

^A DC

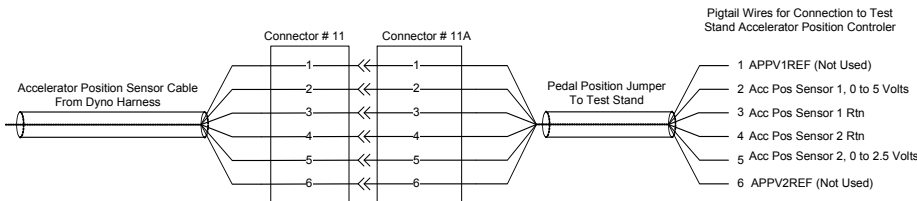

FIG. 2 Accelerator Position Wiring Schematic

Sequence IX Draft, [April 2018 TWB](#)
(Based on document “Seq IX LSPI Test Method_20180412.docx”)

7.17 *Water Pump and Water-Pump Drive*—Install the water pump and pulley, the crankshaft pulley, and the tensioner according to the 2012 Explorer service manual. These are the only components needed to drive the water pump. All other production, front-end, accessory-drive components do not need to be installed. The engine cannot be used to drive any external engine accessory other than the water pump. Pull back the tensioner and install the water-pump drive belt as shown in [FIG. 3](#). Ensure that there is a minimum contact angle of 20° between the drive belt and the water-pump pulley.



FIG. 3 Water-Pump Drive Arrangement

Commented [FM10]: 11. [Update to show annotation](#)

TWB: Please supply updated Fig.

7.18 *Cylinder-block oil separator*

7.18.1 Install a dummy positive crankcase ventilation (PCV) valve (that is, a PCV valve with the internal components removed) in the oil separator on the side of the engine block. Measure crankcase pressure at this location.

8. Engine Preparation

8.1 Environment for Engine Buildup and Measurement Areas—The ambient atmosphere of the engine buildup and measurement areas shall be reasonably free of contaminants. Control the temperature to within ± 3 °C to ensure acceptable repeatability in the measurement of parts dimensions. To prevent moisture forming on cold engine parts that are brought into the buildup or measurement areas, maintain the relative humidity at a nominal maximum of 50 %.

Commented [TB11]: 12.This section was 8.5.1 in previous draft. However it is more appropriate here so have moved and renumbered sections to accommodate.

8.2 Engine Disassembly:

8.2.1 Disassemble the engine and the cylinder head according to the 2.0 L Ecoboost disassembly procedures in the Ford 2012 Explorer Shop Manual. Note the position of all the engine components to ensure they are returned to the same positions when the engine is reassembled.

8.3 Cleaning Engine Components:

Commented [TB12]: 13.This section now covers cleaning cylinder head (8.3.1) and other components (8.3.2) (which was in a separate section in previous draft)

8.3.1 Cylinder Head Preparation and Cleaning:

8.3.1.1 **General**—Use a modified cylinder head obtained from TEI^{14,15,16}.

Formatted: Footnote Reference, Font: 10 pt

8.3.1.2 **New Cylinder Heads**—A new cylinder head that has been modified with pressure-transducer tubes installed, and never used in a previous Sequence IX test, shall be cleaned with Stoddard solvent before assembly. Clean all debris left from the tube installation off the cylinder head.

Formatted: Footnote Reference, Font: 10 pt, Not Superscript/ Subscript

8.3.1.3 **Used Cylinder Heads**—For a cylinder head that has been modified with pressure transducer tubes installed, and has been used in a previous Sequence IX test, clean the bare cylinder head, with tubes (but no valve-train components) in an ultrasonic parts cleaner. Tierra Tech Model MOT500NS^{16,17} has been found suitable for this purpose. Rinse parts with cleaning soap, NAT-50 or PDN-50^{17,18}, before putting them into the ultrasonic cleaner. Use Ultrasonic Solution 7 and B^{16,17,18} in the ultrasonic parts cleaner.

Formatted: Footnote Reference, Font: 10 pt, Not Superscript/ Subscript

Formatted: Footnote Reference, Font: 10 pt, Not Superscript/ Subscript

Formatted: Footnote Reference, Font: 10 pt

Formatted: Footnote Reference, Font: 10 pt, Not Superscript/ Subscript

8.3.1.4 The Cleaning Procedure:

a) Heat the ultrasonic bath to 60 °C (140 °F). When this temperature is attained (but NOT before), add the ultrasonic cleaning solution. For the Tierra Tech Model MOT500NS with a capacity of 6000 L (158 gal), use 20.8 L of ultrasonic solution 7 and 1.9 L (0.5 gal) of ultrasonic solution B. Change the soap and water solution at least after every 25 h of use.

NOTE 2—Quantities will be different for a different size unit.

¹⁶ The sole source of supply of this product known to the committee at this time is TierraTech, Draper Business Park, 12227 South Business Park Drive, Suite 100, Draper, UT 84020. sales@tierratech.com.

¹⁷ The sole source of supply of this material known to the committee at this time is Better Engineering Manufacturing, 8361 Town Court, Baltimore, MD 21236.

b) After 30 min, remove the parts and immediately spray with hot water, followed by solvent and [leave](#) to air dry.

8.3.2 [Cleaning Other Components](#)—Unless otherwise stated, spray clean the following components with solvent, then blow out with pressurized air, and leave to air dry:

- a) Camshafts and all valve train;
- b) Intake manifold/throttle body (unseparated);
- c) Fuel-pump housing with piston;
- d) Vacuum pump and oil screen;
- e) Oil screen and the intake and outlet of the turbocharger - wipe lightly, with a rag wet with solvent. (Do not clean the inside of the turbocharger);
- f) Carbon build up on the injectors - wipe off; variable valve timing
- g) Variable valve timing (VCT) solenoids;
- h) Valve cover;
- i) Turbocharger oil lines.

8.4 *Engine Measurements:*

8.4.1. *Cylinder Bore and Piston Measurements*—See [Table A9.1](#).

8.4.1.1 Measure and record the piston-to-bore clearances at the top, second, and third ring lands and the piston skirt as shown in [Fig. A6.13](#). Use the bore ladder shown in [Fig. A6.14](#) to determine bore diameter positions. Measure the bore in both the longitudinal and transverse directions. To determining the piston-to-bore clearance, calculate the difference between the particular piston diameter location and the average bore diameter for both the transverse and longitudinal directions.

8.4.1.2 Measure and record ring side clearances for the upper and lower compression rings (UCR, LCR). Determine ring side clearance by taking four measurements 90° apart. [Either check clearance with a thickness gauge or by measuring the difference between the thickness of the ring and the height of the corresponding groove.](#)

8.4.1.3 Measure and record ring tension. Obtain ring tension measurements from Test Engineering, Inc. ^{1343,66}

8.4.2 *Cylinder head measurements*—See [Table A9.2](#).

Commented [TB13]: 14. There is no Fig for bore ladder in the original draft. Please supply.

Commented [FM14]: 15. Side clearance measurement method is still TBD

TWB: PLEASE SUPPLY

Formatted: Footnote Reference, Font: 10 pt

Formatted: Footnote Reference, Font: 10 pt, Not Superscript/ Subscript

Sequence IX Draft, [April 2018 TWB](#)
(Based on document “Seq IX LSPI Test Method_20180412.docx”)

8.4.2.1 To determine the valve stem-to-guide clearance, measure the diameter of the valve stem at 38 mm from the tip of the valve, and the valve guide at 19.5 mm from the top of the valve guide.

8.4.2.2 For the intake and exhaust valve springs, measure and record spring free length and spring [tension](#) at a compressed height of 28.7 mm. Verify the compressed spring [tension](#) is 460 N ± 21 N. Reject any springs not meeting this criteria.

[8.4.3 Crankshaft Measurements—See Table A9.3.](#)

8.5 *Miscellaneous Engine Components-Preparation:*

8.5.2 *Throttle Body:*

8.5.2.1 Clean the butterfly and bore of the throttle body with Berryman Chemtool B12^{18,66} carburetor cleaner and air-dry before each test. Do not disassemble the throttle body as this will cause excessive wear on the components. The idle-air screw can be removed for the cleaning process. Fully close the idle-air screw during test operation.

8.5.2.2 There is no specific life for the throttle body. However, the clearance between the bore and the butterfly will eventually increase and render the body unserviceable. When the clearance becomes too great to allow control of speed, torque, and air-fuel ratio, discard the throttle body.

8.6 *Engine Assembly:*

8.6.1 Assemble the engine according to the 2.0 L EcoBoost assembly procedures in the 2012 Explorer Shop Manual, except as noted in section 7. Ensure all components (that is, pistons, rings, bearings, etc.) are replaced in the same positions used originally when assembled at the factory.

8.6.2 *Sealing Compounds*—Use a silicon-based sealer, as needed, on the contact surfaces between the rear-seal housing and oil pan and the front cover and cylinder block, cylinder head and oil pan. Use Motorcraft Gasket Maker (TA-16)^{69,66} or equivalent between the 6th intake and exhaust camshaft cap and the cylinder head. Use silicon-based sealer sparingly since it can elevate the indicated silicon content of the used oil.

NOTE 3—Non-silicon liquid or tape thread sealers may be used on bolts and plugs.

8.6.3 *Gaskets and Seals*—Install new gaskets and seals during engine assembly.

Commented [TB15]: 16. The draft 20170505 has a Table 4 Crank Measurements – this is now Table A9.3. There is no text referring to this Table, however. Is it the intent to record the main and rod bearing measurements? If so, we need a section here. Please provide the text.

Formatted: Footnote Reference, Font: 10 pt, Not Superscript/ Subscript

Formatted: Footnote Reference, Font: 10 pt

Formatted: Footnote Reference, Font: 10 pt, Not Superscript/ Subscript

¹⁸ The sole source of supply of this product known to the committee at this time is Berryman Products, Inc, 3800 E. Randol Mill Rd, Arlington, TX 76011. Tel: +1 800 433 1704; www.berrymanproducts.com.

8.7 *Cylinder Head Assembly:*

8.7.1 Cylinder heads may be used as long as they remain within service specifications. Refer to the 2012 Explorer Service Manual.

8.7.2 Replace the valves on cylinder heads reused on another engine block,

8.7.3 If a cylinder head is removed from an engine block ahead of schedule due to broken pistons, short-block failure, or lack of test severity, the laboratory may reuse the cylinder head without replacing the valves provided they are within service limit

8.7.4 Assemble the cylinder heads in accordance with the service manual. Lap the valves before installation and install new intake- and exhaust-valve seals. Set the valve lash in accordance with the procedure in the workshop manual and record the valve lash.

8.7.5 Vacuum check the valve ports before use.

8.8 *Engine Installation on Test Stand*—Install the engine onto the stand as described in 7.6.2. Install all engine components external to the long-block according to the 2.0L Ecoboost assembly procedures in the 2012 Explorer Shop Manual, where applicable. Connect the engine to all external laboratory systems identified in Section 6, in accordance with laboratory procedures.

8.9 *Pressure Sensor Installation*—Once the sensor tubes and modified valve cover are installed (see 7.4.4 and 7.4.5), install pressure sensors into the pressure-sensor tube using the [sensor-installation tool](#) described in [Table A8.8](#) and torque the sensors to 1.5 N·m.

8.10 *New-Engine Break In*—Once a new engine has been installed on the test stand, perform the eight-hour break-in procedure shown in [Table 2](#) using oil TMC 220¹⁹.

Commented [TB16]: 17.Table A8.8 gives no details of the tools –manufacturer, P/N, etc. Please update Table A8.8

TABLE 2 Sequence IX Eight-Hour, Break-In Procedure

Step	Engine speed, r/min	Engine torque, N·m	Time per stage, h:min	Total Time, h:min
Install new oil filter and charge engine with 4.2 kg of new oil				
1	1000 ^{idle}	0	0:30	0:30
Oil change 1: Shut engine down, drain used oil, and remove oil filter. Allow oil to drain for 20 min. Install new oil filter and add 4.2 kg grams of new oil.				
Start engine and idle for 5 min				
2	1500	38	0:30	1:00
3	2000	72	0:30	1:30
4	2500	111	0:30	2:00

Commented [TB17]: 18.Since the column is headed “engine speed”, suggest we enter 1000 with a footnote saying this is the idle speed.
 19.
 20.Since we have now defined idle speed here, we need not specify the idle speed subsequently

¹⁹ Available from the ASTM Test Monitoring Center, 6555 Penn Avenue, Pittsburg, PA 15206-4489, Attention: Administrator.

Sequence IX Draft, [April 2018 TWB](#)
 (Based on document “Seq IX LSPI Test Method_20180412.docx”)

5	3000	135	0:30	2:30
6	3000	150	3:15	5:45
7	2000	72	0:15	6:00
8	3250	155	0:15	6:15
9	3500	155	0:15	6:30
10	3750	155	0:15	6:45
11	4000	155	1:15	8:00
Bring engine to idle speed for 5 min, then shut down				
Oil change 2: Drain used oil and remove oil filter. Allow oil to drain for 20 min. Install new oil filter and add 4.2 kg new oil.				

^A [This is the idle speed.](#)

8.10.1 The controlled quantities during the break-in are listed in [Table 3](#). All other controls are left wide open or free flowing. The engine does not produce enough heat in the early steps to reach all target temperatures. All controlled quantities shall be on target at the beginning of Step 4.

Table 3. Sequence IX Controlled Quantities for the Eight-Hour Break-in

Quantity, unit	Controlled value
Coolant-out temperature, °C	85
Oil-gallery temperature, °C	100
Inlet-air pressure, kPa (gauge)	0.05
Air-charge temperature, °C	37
Inlet-air temperature, °C	30
Humidity, g/kg	11.4
Fuel pressure, kPa	450 \pm 37
Coolant flow rate	Valve wide open

8.11 Temperature Measurements:

8.11.1 General:

8.11.1.1 Temperature measurement locations are specified in 8.11.4.

8.11.1.2 Use thermocouples that can be calibrated with an accuracy of ± 0.5 °C. Use Ford-specified temperature sensors for Electronic Engine Control (EEC) inputs.

8.11.2 Equipment:

8.11.2.1 Use premium, sheathed thermocouples in all cases except the intake-air thermocouple which may A.6.2 be an open-tip type. Use thermocouples with a diameter of 3 mm and a length of 100 mm.

8.11.2.2 Thermocouples, wires, and extension wires shall be matched to perform in accordance with the special limits of error as defined in ANSI MC96.1.

8.11.3 Calibration— Refer to **Table 4** for calibration interval of thermocouples. The temperature-measurement system shall indicate within ± 0.5 °C of the laboratory calibration standard. The calibration standard shall be traceable to NIST²⁰.

8.11.4 Locations for Engine-Temperature Sensors:

8.11.4.1 *Engine-Coolant Inlet*—Install the sensor in the coolant inlet on the engine (P/N OHTVH-008-1^{27,66}) perpendicular to the run. Install sensor with the tip in the center of the stream of flow (see **Fig. A6.2**).

8.11.4.2 *Engine-Coolant Outlet*—Install the sensor in the coolant outlet on the engine (P/N OHTVH-009-1^{27,66}) perpendicular to the run. Install sensor with the tip in the center of the stream of flow (see **Fig. A6.2**).

8.11.4.3 *Engine-Oil Gallery*—Install the tip of the sensor at the center of the flow stream in the external, oil-filter adapter (see **Fig. A6.12**) through the hole for the oil-pressure switch (which is not used). Install a tee to accept this temperature sensor and attach the oil-pressure line.

8.11.4.4 *Engine-Oil-Filter In*—Install the tip of the sensor at the center of the cross fitting attached to the side opposite from the engine-oil-inlet temperature sensor on the oil-filter adaptor. Modify the adapter with a 1/8 NPT hole to access the oil passage (see **Fig. A6.12**).

8.11.4.5 *Inlet Air*—Install the tip of the thermocouple midstream in the air-cleaner box downstream of the filter (see **Fig. A6.8**). Insertion depth shall be 37 mm \pm 2 mm.

Commented [TB18]: 21.Re your comment to 8.12.4. Do we want names in method and report forms to match for temps as well as pressures?
22.If so do we change the names in the method or the names in the report forms?

Formatted: Footnote Reference

Formatted: Footnote Reference, Not Superscript/ Subscript

Formatted: Footnote Reference

Formatted: Footnote Reference, Not Superscript/ Subscript

²⁰ National Institute of Standards and Technology, 100 Bureau Drive, Stop 2300, Gaithersburg, MD 20899-2300. Email: calibrations@nist.gov. Phone: +1 301 975 2200.

Sequence IX Draft, April 2018 TWB
(Based on document "Seq IX LSPI Test Method_20180412.docx")

8.11.4.6 *Fuel*—Install the sensor in the low-pressure fuel line no more than 155 mm from the high-pressure pump. Use an appropriate size “T” fitting to ensure the sensor and fitting do not interfere with the fuel flow (see Fig A6.7).

8.11.4.7 *Air Charge*—Install the sensor in the intercooler outlet tube 25 mm ± 2 mm downstream from the MAPT sensor (see Fig A6.9).

8.11.4.8 *Exhaust*—Install a sensor 140 mm ± 12 mm downstream on the exhaust flange (see Fig. A6.6).

8.11.4.9 *Oil Sump*—Measurement of oil-ump temperature is optional. If it is measured, install a sensor through the production oil-drain-plug hole.

8.12 Pressure Measurements:

8.12.1 *General*—Pressure measurement locations are specified in 8.12.4.

8.12.2 *Equipment*—The accuracy and resolution of the pressure-measurement sensors and the complete pressure-measurement system shall meet the requirements of the Data Acquisition and Control Automation II (DACA-II) Task Force Report¹⁹²⁴. Replace pressure sensors that are part of the EEC system with Ford-specified equipment.

NOTE 4—Tubing between the pressure-tap locations and the final pressure sensors should incorporate condensate traps, as indicated by good engineering practice. This is particularly important in applications where low, air pressures are transmitted by means of lines which pass through low-lying trenches between the test stand and the instrument console.

8.12.3 *Calibration*—Refer to Table 4 for [the calibration interval for the pressure sensors](#). Pressure measurement systems shall conform to the guidelines in DACA-II Task Force Report¹⁹²⁴. The calibration standard shall be traceable to NIST²⁰²¹.

8.12.4 Locations for Pressure-Measurement Sensors:

8.12.4.1 *Intake Manifold*—Measure **intake manifold pressure** (MAP) at the port downstream of the throttle body on the intake manifold (see Fig. A6.9).

8.12.4.2 *Engine-Oil Gallery*—Measure oil-pump pressure in the external oil-filter adapter (see Fig. A6.11) through the hole for the oil-pressure switch (not used). Install a tee to accept the temperature sensor and attach the oil pressure line.

8.12.4.3 *Coolant Pressure*—Measure coolant pressure at the top of the coolant reservoir as shown in Fig. A6.3.

8.12.4.4 *Fuel*—Measure fuel pressure in the lower-pressure fuel line at the exit of the stand fuel pump.

Formatted: Footnote Reference

Formatted: Footnote Reference

Formatted: Footnote Reference

Commented [FM19]: 23.Need to update all names that are used in report to match:

TWB: Have changed names so they match those in report forms. Is this correct or should they be the other way round?

Commented [TB20]: 24:There are several pressure measurements listed here that are not in the report forms. Is this OK?
Eg, engine oil gallery, pre-intercooler, boost (post-intercooler), cylinder head oil.

Commented [TB21]: 25.You deleted “MAP” but we need to define it here as it also occurs in Table A8.6

8.12.4.5 *Crankcase*—Measure crankcase pressure at the dummy positive crankcase ventilation (PCV) valve in the cylinder-block oil separator.

8.12.4.6 *Exhaust Back Pressure*—Measure the exhaust back-pressure with the exhaust-gas sampling probe located $76 \text{ mm} \pm 12 \text{ mm}$ downstream of the exhaust flange (see [Fig. A6.6](#)). A sensor capable of absolute or gauge measurement corrected with barometric pressure reading is recommended. Install a condensate trap between the probe and sensor to accumulate water present in the exhaust gas.

8.12.4.7 *Inlet Air*—Measure inlet air pressure in the air-cleaner box downstream of the air filter (see [Fig A6.8](#)).

8.12.4.8 *Pre-Intercooler*—Measure the pre-intercooler pressure with the sampling probe located $155 \text{ mm} \pm 50 \text{ mm}$ downstream of the turbocharger flange (see [Fig A6.9](#)).

8.12.4.9 *Boost Pressure (Post-Intercooler)*—Measure the boost pressure with the sampling probe located downstream of the intercooler and at least 305 mm upstream of the MAPT sensor (see [Fig A6.9](#)).

8.12.4.10. *Cylinder Head Oil*—Measure cylinder-head pressure at the oil gallery plug on the left side of the cylinder head next to the belt tensioner.

Commented [FM22]: 26.Insert picture in figures of this location.

8.13 *Flow-Rate Measurements:*

8.13.1 *General*—With the exception of engine coolant, equipment for measuring the flow rate for the four required quantities is not specified. This provides opportunity for adaptation of existing test-stand instrumentation (see X1.4.5 for suitable mass-flow meters).

8.13.2 *Coolant*—Determine coolant-flow rate using a flowmeter with an accuracy of $\pm 1 \%$ (see [Fig. A6.3](#)). A suitable flowmeter is available from the supplier in Appendix X.1.???. Take precautions to prevent air pockets from forming in the lines to the flow meter. Transparent lines or bleed lines, or both, are beneficial in this application. Ensure that the manufacturer’s requirement for orientation and straight sections of pipe are installed immediately up- and downstream of the flowmeter.

Commented [TB23]: 27.There is no supplier info provided in 10.4.1. for flowmeter coolant. (note: this is X2.1.6 in 20170505 draft). Please give supplier name and flowmeter model.

Commented [FM24]: 28.Find part numbers of the flow meters being used now.
29.Move to engine coolant flow meter location section.

8.13.3 *Calibration*—Refer to [Table 4 for the calibration interval for the flow meters](#). Calibrate the flowmeters as installed in the system at the test stand with test fluid. Calibrate the flowmeters with a turbine flowmeter or by a volume/time method at Stage 1 and 2 operating conditions.

8.13.4 *Locations for Flow-Rate Measurements:*

8.13.4.1 *Engine Coolant*—Install the flowmeter at either the coolant inlet or outlet sides of the engine.

8.13.4.2 *Fuel*—Measure fuel-flow rate in kg/h on the low-pressure fuel system before the high-pressure engine fuel pump.

8.14 [Humidity Measurement](#).

8.15 [O₂-Oxygen Measurement](#).

8.16 *In-cylinder Pressure Measurement*—Use the manufacturer’s calibration requirements for the in-cylinder pressure sensors. Refer to Table 4 for the calibration interval.

8.17 *Crank-angle Measurement*—Use the manufacturer’s calibration requirements for the crankangle encoder. Refer to Table 4 for the calibration interval.

8.18 *Charge Amplifier*—Use the manufacturer’s calibration requirements for the charge amplifier. Refer to Table 4 for the calibration interval.

Table 4 Instrumentation Calibration Periods

Instrument Type	Section	Calibration Period
Load Cell	?	Prior to every reference test
Thermocouples	8.11	Every 3 months
Pressure Sensors	8.12	Every 3 months
Flow Meters	8.13	Every 3 months
In-Cylinder Pressure Sensors	8.16	Every 300 h
Crank Angle Encoder	8.17	Every 300 h
Charge Amplifier	8.18	Every 300 h

Reference sections for each sensor type.

9. Reagents and Materials

9.1 *Solvents and Cleaners Required*—No substitutions are allowed. (**Warning**—Use adequate safety provisions with all solvents and cleaners.)

9.1.1 *Solvent*—Use only mineral spirits (for example, Stoddard Solvent) meeting the requirements of Specification D235, Type II, Class C for volume fraction of aromatics 0 % to 2 %, flash point 61 °C, minimum, and color not darker than +25 on Saybolt Scale or 25 on Pt-Co Scale. (**Warning**—Combustible. Health hazard.) Obtain a Certificate of Analysis for each batch of solvent from the supplier.

9.1.2 *Organic Solvent*—Use Penmul L460^{21,66}. (**Warning**—Combustible. Health hazard.)

²¹ The sole source of supply of this product known to the committee at this time is Penetone Corporation, PO Box 22006, Los Angeles, CA 90022.

Commented [TB25]: 30.Do we not require some text re the humidity sensor and its calibration?

Commented [TB26]: 31.Do we not require some text re O2 sensors and their calibration?

Commented [FM27]: 32.Use manufacturers recommended calibration requirements.
 33.Do not exceed 300 hours
 34.**TWB: Have added text and provided info in Table 4. Is it correct?**

Commented [FM28]: 35.Use manufacturers recommended calibration requirements.
 36.Do not exceed 300 hours
 37.**TWB: Have added text and provided info in Table 4. Is it correct?**

Commented [FM29]: 38.Use manufacturers recommended calibration requirements.
 39.Do not exceed 300 hours **TWB: Have added text and provided info in Table 4. Is it correct?**

Commented [TB30]: 40.There is no section dealing specifically with load cell.

Commented [TB31]: 41.Is this correct?

Commented [TB32]: 42.Is this correct?

Commented [TB33]: 43.Is this correct?

Commented [TB34]: 44.Is this correct?

Commented [TB35]: 45.I have added a column to allow reference to relevant section. Is this what you meant?

Formatted: Footnote Reference, Font: 10 pt, Not Superscript/ Subscript

Formatted: Footnote Reference, Font: 10 pt

Sequence IX Draft, [April 2018 TWB](#)
(Based on document “Seq IX LSPI Test Method_20180412.docx”)

9.1.3 *Ultrasonic Cleaner*—Use Tierratech ultrasonic solution 7 and B12^{18+8,66}.

9.1.4 *Carburetor Cleaner*—Berryman Chemtool B12^{18+8,66}.

9.2 *Test Fuel*—Approximately 340 L of Haltermann HF2021 EPA Tier 3 EEE Emission Certificate test fuel^{12+3,66} are required for each test. (**Warning**—Flammable, health hazard.)

9.3 *Sealing Compound*—Loctite²² 565^{23,66}.

9.4 *Parts Cleaning Soap*, NAT-50 or PDN-50 are acceptable^{17+7,66} (**Warning**—Health hazard.)

10. Calibration and Standardization

10.1 *General:*

10.1.1 Annex A2 describes calibration procedures using the TMC reference oils, including their storage and conditions of use, the conducting of tests, and the reporting of results. Determine the acceptability of a reference oil according to the Lubricant Test Monitoring System (LTMS).

10.1.2 Annex A3 describes general maintenance activities involving TMC reference oils, including special reference oil tests, special use of the reference oil calibration system, donated reference oil test programs, introducing new reference oils, and TMC information letters and memoranda.

10.1.3 Annex A4 provides general information regarding new laboratories, the role of the TMC regarding precision data, and the calibration of test stands used for non-standard tests.

10.2 *Activities specific to the Sequence IX :*

10.2.1 Verify the calibration of test stands with reference oils supplied by the TMC (see 10.2.2). Consult **Annex A2** prior to attempting calibration of a new stand. Stand calibration tests are normally conducted upon expiration of either the 90 d calibration time period, after completing five non-reference oil tests, or **150** engine hours at start of test. However, calibration time periods may be adjusted by the TMC. Any non-reference oil test started within 90 d of the previous calibration test and with less than 150 engine hours at the start of test is considered within the calibration period, provided the 5 allowed non-reference oil tests that have been completed since the previous calibration test in the stand are not exceeded.

10.2.2 The TMC provides a reference oil sample of 22.4 L for each stand calibration test.

10.3 *Unacceptable Calibration Results:*

10.3.1 It is recognized that a certain percentage of calibration tests fall outside the acceptance limits because of the application of statistics in the development of the acceptance

²² Loctite is a registered trademark of Henkel Corporation.

²³ Available from Henkel. Corporation, One Henkel Way, Rocky Hill, CT 06067, USA. www.henkeln.com.

Formatted: Footnote Reference, Font: 10 pt

Formatted: Footnote Reference, Font: 10 pt, Not Superscript/ Subscript

Formatted: Footnote Reference, Font: 10 pt

Formatted: Footnote Reference, Font: 10 pt, Not Superscript/ Subscript

Formatted: Footnote Reference, Font: 10 pt

Formatted: Footnote Reference, Font: 10 pt, Not Superscript/ Subscript

Formatted: Footnote Reference, Font: 10 pt, Not Superscript/ Subscript

Formatted: Footnote Reference, Font: 10 pt

Formatted: Footnote Reference, Font: 10 pt, Not Superscript/ Subscript

Commented [FM36]: 46. Have we agreed to 150 hours 47.160 hours would allow for all 5 candidate runs to complete 8 iterations.

Sequence IX Draft, [April 2018 TWB](#)
(Based on document “Seq IX LSPI Test Method_20180412.docx”)

limits. Failure of a reference oil test to meet e_i (prediction error) or Z_i (exponentially weighted moving average) control chart limits²⁴ can be indicative of a false alarm or a stand, laboratory, or industry problem. When this occurs, the laboratory, in conjunction with the TMC, shall attempt to determine the problem source. The TMC may solicit input from industry expertise (other testing laboratories, the test sponsor, ASTM Technical Guidance Committee, Sequence IX Surveillance Panel, and so on) to help determine the cause and extent of a problem. The Sequence IX Surveillance Panel adjudicates industry problems.

10.3.2 If the TMC determines the problem is a false alarm and is stand-related, there is no impact on other non-reference tests running in other stands within the laboratory. If the TMC determines the problem is laboratory-related, non-reference tests run during the problem period shall be considered invalid, unless there is specific evidence to the contrary for each individual test.

10.3.3 The TMC reschedules a calibration test once it is satisfied that no particular problem exists or the problem has been resolved. The laboratory shall provide adequate documentation to support conclusions reached during this process. Attach this documentation to the acceptable calibration test report. It shall provide sufficient information to show how the problem related to other tests operated during the same period.

10.4 *Test Stand Modifications*—A nonstandard test includes any test completed under a modified procedure requiring hardware or controller modifications to the test stand. The TMC determines whether another calibration test is necessary after the modifications have been completed.

10.5 *Test Numbering System:*

10.5.1 *Acceptable Tests*—The test number shall follow the format *AAA-BB-CCCC-DDD* where *AAA* represents the test stand number, *BB* represents the number of tests on the stand, *CCCC* represents the engine number, and *DDD* represents of tests on the engine. As an example, 6-102-32-5 represents the 102nd test on Stand 6 and the 5th test on engine number 32. Consecutively number all tests on a given stand and engine.

10.5.2 *Unacceptable or Aborted Tests*—If a calibration test is aborted or the results are outside the acceptance limits, the *DDD* portion of the test number for subsequent calibration test(s) shall include a letter suffix. The completion of any amount of operational time on tests will cause the test number to increase by one.

²⁴ see LTMS document available from TMC at www.astmtmc.cmu.edu/ftp/docs/ltms/ltms.pdf.

Sequence IX Draft, [April 2018 TWB](#)
 (Based on document “Seq IX LSPI Test Method_20180412.docx”)

10.5.3 Re-reference the engines once removed from the test stand and re-installed, even if the test number and time criteria are met by the engine. Laboratories shall inform the TMC with a written explanation when a test engine is removed from a test stand and installed onto another test stand. Calibrate engines moved from one stand into another test stand as a new stand/engine.

Commented [FM37]: 48. Make sure we identify the critical engine components that can effect calibration. See Caterpillar Aeration test.

TWB: Please supply this info.

11. Test Procedure

11.1 *Oil Flush Procedure*—For each new test, perform two oil flushes using the test oil as detailed below:

11.1.1 Install a new oil filter and charge the engine with 4.2 kg of new oil.

11.1.2 *Warm Up*—Start the engine and operate at [idle speed \(1000 r/min\)](#) for 2 min.

11.1.3 Ramp to 2000 r/min and 70 N•m within 2 min. Control to the warm-up conditions listed in [Table 5](#). Maintain conditions for 15 min (including ramp time).

Commented [TB38]: 49. For your info, although we have defined idle speed as 1000 r/min in Table 2 suggest we repeat it here for the convenience of the user but do not do so hereafter on the grounds it is unnecessary repetition.

Commented [FM39]: 50. What conditions should we standardize on for flush. Make new table with appropriate temperatures

11.1.4 Ramp to 1000 r/min within 2 min and hold at this speed for 2 min (including ramp time).

11.1.5 Shut-down engine.

11.1.6 Drain the oil from the engine for at least 20 min.

11.1.7 Repeat 11.1.1 to 11.1.6 for the second flush.

TABLE 5 Warm-Up Conditions

Controlled Quantity, unit	Set Point
Coolant-out temperature, °C	95
Oil-gallery temperature, °C	95
Air-charge temperature, °C	43
Inlet-air temperature, °C	30
Inlet-air pressure, kPa (absolute)	0.05
Exhaust back pressure, kPa (absolute)	104
Humidity, g/kg	11.4
Fuel pressure, kPa	450 ± 37

Sequence IX Draft, [April 2018 TWB](#)
(Based on document “Seq IX LSPI Test Method_20180412.docx”)

11.2 *Oil Conditioning Procedure:*

11.2.1 *General*—Prior to initiating the test cycle, condition the test oil as described in this section.

11.2.2 Install a new filter and charge the engine with 4.2 kg of test oil.

11.2.3 *Warm Up*—Start the engine and operate at idle [speed](#) for 2 min.

11.2.4 Ramp to 2000 r/min and 100 N•m in 60 s. Ramp to the warm-up conditions listed in [Table 5](#) and run at these conditions for 15 min.

11.2.5 Ramp to 1750 r/min and 269 N•m in 60 s.

11.2.6 Hold at 1750 r/min and 269 N•m and control to test condition temperatures for 60 min.

11.2.7 Ramp to the cool-down conditions shown in [Table 6](#).

11.2.8 Maintain conditions for 15 min (including ramp times).

11.2.9 Ramp to idle [speed](#) and hold for 2 min.

11.2.10 Shut-down the engine for a minimum of 10 min. Take oil dip and inspect engine and stand for oil leaks and any obvious damage.

TABLE 6. Cool-Down Conditions

Controlled Quantity, units	Set Point	Ramp time, min
Engine speed, r/min	2000	1
Engine torque, N•m	50	1
Coolant out temperature, °C	45	15
Oil-gallery temperature, °C	45	15
Inlet-air temperature, °C	30	N/A ^A
Air-charge temperature, °C	30	N/A ^A
Inlet-air pressure, kPa (absolute)	0.05	N/A ^A
Exhaust back pressure, kPa (absolute)	104	N/A ^A
Humidity, g/kg	11.4	N/A ^A
Fuel pressure, kPa (gauge)	450 ± 37	N/A ^A

^A Not applicable.

Sequence IX Draft, [April 2018 TWB](#)
(Based on document “Seq IX LSPI Test Method_20180412.docx”)

11.3 *Test Cycle*—For one complete test, carry out the following test cycle four times. (Each cycle is referred to as one iteration, the four cycles being denoted as iterations A, B, C and D).

11.3.1 *Warm Up*—Start the engine and operate at idle [speed](#) for 2 min.

11.3.2 Ramp to 2000 r/min and 100 N•m in 60 s. Control to the warm-up conditions listed in [Table 5](#) and run at these conditions for 15 min.

11.3.3 Ramp to the test conditions shown in [Table 7](#) and hold for 25 min. (including ramp times).

11.3.4 After 25 min, record combustion analysis data using AVL Indicom for 175,000 combustion cycles. (See [Annex A11](#) for combustion analysis settings.)

11.3.5 Ramp to the cool-down conditions shown in [Table 6](#) and maintain these conditions for 15 min (including ramp times).

11.3.6 Ramp to idle [speed](#) and hold for 2 min. During this idle stage, take oil sample as follows:

11.3.6.1 Take a 150 mL purge sample followed by a 30 mL sample. Retain the 30 mL oil sample for analysis.

Commented [FM40]: 51.Where is the oil sample taken from?

11.3.7 Shut-down the engine and return the 150 mL purge sample. Leave engine down for a minimum of 10 min.

11.3.7.1 Take oil dip and inspect engine and stand for oil leaks and any obvious damage. Oil level should be above the minimum indicator on the dip stick.

11.3.8 Carry out 11.3.1 to 11.3.7.1 for a maximum of eight attempts or until four valid iterations have been recorded, whichever comes first.

Commented [FM41]: 52.This is where the number of allowable iterations is mentioned.

[11.3.8.1 Iteration Validity Requirements—a valid iteration requires that:](#)

- a) [there shall be at](#) least 170,000 valid engine cycles per cylinder.
- b) [all](#) controlled parameters [shall](#) have a positive final QI.

11.3.9 Record the operational summary for each iteration A through D on Forms 5 to 8 of the Report Forms (see A12).

TABLE 6 Test Conditions

Controlled Quantity, unit	Set Point	Ramp times, min
Engine speed, r/min	1750 ± 20	1
Torque, N•m	269 ± 5	1
Coolant-out temperature, °C	95 ± 0.5	< 20

Sequence IX Draft, [April 2018 TWB](#)
 (Based on document "Seq IX LSPI Test Method_20180412.docx")

Oil-gallery temperature, °C	95 ±0.5	< 20
Air-charge temperature, °C	43 ±0.5	< 20
Inlet-air temperature, °C	30 ±0.5	< 20
Fuel temperature, °C	30 ±0.5	N/A ^A
Exhaust back pressure, kPa (absolute)	104 ± 2	N/A ^A
Inlet-Air Pressure, kPa (gauge)	0.05 ±0.02	N/A ^A
Humidity, g/kg	11.4 ±1	N/A ^A
Fuel Flow Rate ^B , kg/h	15.4 _	N/A ^A
Fuel Pressure, kPa (gauge)	450 ±37	N/A ^A
Coolant Flow Rate, L/min	55 ±2	N/A ^A

^A Not applicable.

^B Fuel flow is a target only.

11.4 End of Test

11.4.1 Start the engine and operate at idle speed for 2 min.

11.4.2 Ramp to 2000 r/min and 70 N•m within 2 min. Control to the warm-up conditions listed in Table 5 until the oil temperature reaches 95° C.

11.4.3 Ramp to 1000 r/min within 2 min and hold at this speed for 2 min (including ramp time).

11.4.4 Shut down the engine.

11.4.5 Turn off the fuel supply.

11.4.6 Turn off the chilled and process water.

11.4.7 Shut off or remove air intake supply.

11.4.8 When the engine-oil temperature is less than 80° C, drain the oil from the engine for at least 20 min.

Commented [FM42]: 53.Review EOT verbiage at next meeting

12. Determination of Test Results

12.1 Steps for Calculating Low-Speed Preignition (LSPI) Cycles

12.1.1 General:

12.1.1.1 The AVL combustion analysis equipment and the AVL IndiCom software are used to identify preignition events.

12.1.1.2 The procedure described in this section is intended to be used to evaluate complete test iterations between 170,000 and 175,000 engine cycles. If the test iteration does not contain at least 170,000 engine cycles, the iteration is invalid – see 12.2.1.6.

12.2 Removal of Invalid Cycles:

12.2.1 To determine combustion cycle validity, evaluate each cylinder separately. Invalid combustion cycles are removed from each cylinder's data set prior to performing the peak pressure (*PP*) and mass fraction burn at 2 % (*MFB2*) LSPI calculations.

NOTE 5: *MFP2* is the measurement of the engine crankshaft angle, in °, measured when 2 % of the mass fraction of fuel has been burned during a combustion cycle.

12.2.1.1 Use the following criteria to identify invalid cycles:

- a) Remove all cycles with a *MFB2* < -30°.
- b) Remove all cycles with a *PP* < 2 MPa.

12.2.1.4 After all invalid *MFB2* and *PP* cycles have been removed (see 12.2.1.1), remove all cycles with a pressure minimum voltage *PMINV* < mean of remaining *PMINV* - 0.5 V or greater than the remaining *PMINV* + 0.5 V. For example, if the mean *PMINV* of the remaining engine cycles on cylinder 1 is -8.02 V, remove all cycles with *PMINV* < -8.52 V and with *PMINV* > -7.52 V.

12.2.1.6 Once all invalid cycles are removed, proceed to 12.3 using only the first 170,000 valid engine cycles for each cylinder. If there are fewer than 170,000 valid engine cycles on any cylinder, the iteration is considered invalid. Record the iteration as invalid and report the number of engine cycles run, along with the total number of invalid engine cycles in the test report.

12.3 Remove abnormal *PP* cycles individually for each cylinder as follows:

12.3.1 Remove obvious outliers.

NOTE 6—The mathematical method of estimating quantiles decreases in accuracy the further from normality so obvious outliers should be eliminated prior to proceeding.

12.3.1.1 Remove *PP* > 9 MPa (it is assumed that any cycle with *PP* > 9 MPa is an outlier).

12.3.2 Calculate the following quantities for the remaining results:

- a) Mean (*M*)

Commented [TB43]: 54. Note that *PP*, *MFB2*, *PMINV* are quantities and the SI requires their symbols be written in italic font.

Commented [TB44]: 55. Have revised because *MFP2* is an angle.

Sequence IX Draft, [April 2018 TWB](#)
(Based on document "Seq IX LSPI Test Method_20180412.docx")

- b) Standard deviation (S)
- c) Skewness (s)
- d) Kurtosis (K)

12.3.3 Determine the number of standard deviations for the distributions subject to skewness and kurtosis corresponding to the 5 standard deviations that are appropriate for a valid normal distribution.

12.3.3.1 Simultaneously solve for B, C and D in Eqs (1), (2) and (3) using the values for K and s determined in 12.3.2:

$$1 = B^2 + 2C^2 + 6BD + 15D^2 \quad (1)$$

$$s = 8C^3 + 6B^2C + 72BCD + 270CD^2 \quad (2)$$

$$K = 3B^4 + 60B^2C^2 + 60C^4 + 60B^3D + 936BC^2D + 630B^2D^2 + 4500C^2D^2 + 3780BD^3 + 10395D^4 - 3 \quad (3)$$

12.3.3.2 Then calculate F , an estimate of the quantile corresponding to $Z = 5$:

$$F = -C + BZ + CZ^2 + DZ^3$$

or

$$F = -C + B(5) + C(5^2) + D(5^3)$$

12.3.3.3 The initial solution for F should be between 4 and 10. If the result is outside of that range, the iteration is considered invalid.

12.3.3.4 If the initial solution for F is between 4 and 10, then calculate the derivative of the equation (#) between Z values of 0 and 5, at a resolution of 0.1 Z. If any result is less than zero, the iteration is considered invalid

12.3.3.4 If the initial solution for F is between 4 and 10, then calculate F for all z values between 0 and 5 at a resolution of 0.1 Z. The maximum value of all F values over this range of Z values should be at Z=5. If not, the iteration is considered invalid.

NOTE 7— F will generally be on the order of 5 to 10 on the first iteration and 5 to 7 on the last iteration.

12.3.4 Omit those cycles with $PP > \frac{\text{Mean } M}{F} \times S$, which are outliers.

12.3.5 If no outliers are found in 12.3.4, process is complete. If outliers are found in 12.3.4, repeat steps 12.3.3.1 through 12.3.4 until no new outliers are found.

Commented [FM45]: 56. Verify the definition of Kurtosis used here, then explicitly state it in the procedure. Ask Doyle

Commented [FM46]: 57. Provide guidance on how to select the appropriate solution set, possibly by providing an expected range of B, C, and D.

Commented [FM47]: 58. Better define which solution set should be used.

Commented [TB48]: 59. Mean has been assigned the symbol M in 12.3.2 so we can use symbol here. Also the SI does not allow text and mathematical symbols such as $>$ to be mixed so we have to use a symbol for "mean"

12.3.6 Record the total number of outliers is from 12.3.1.1 and 12.3.4.

Commented [FM49]: 60. This should be explained more clearly.
TWB: please supply revised text.

12.4 Remove abnormal *MFB2* cycles individually for each cylinder [as follows](#):

12.4.1 Remove obvious outliers (see [Note 6](#)).

12.4.1.1 Remove $MFB2 < 0^\circ$ (It is assumed that any cycle with a $MFB02 < 0^\circ$ is an outlier.)

12.4.2 Calculate the following quantities for the remaining results:

- a) Mean (*M*)
- b) Standard deviation (*S*)
- c) Skewness (*s*)
- d) Kurtosis (*K*)

Commented [FM50]: 61. Verify the definition of Kurtosis used here, then explicitly state it in the procedure. Ask Doyle

12.4.3 Determine the number of standard deviations for the distributions subject to skewness and kurtosis corresponding to the -5 [standard deviations](#) that [are](#) appropriate for a valid normal distribution.

12.4.3.1 Simultaneously solve for B, C and D in Eqs (1), (2) and (3) using the values for *K* and *s* determined in 12.4.2.

Commented [FM51]: 62. Provide guidance on how to select the appropriate solution set, possibly by providing an expected range of B, C, and D.
TWB: Please provide text

12.4.3.2 Then calculate *F*, an estimate of the quantile corresponding to $Z = -5$.

$$F = -C + BZ + CZ^2 + DZ^3$$

or

$$F = -C + B(-5) + C(-5)^2 + D(-5)^3$$

NOTE 8—*F* will generally be on the order of -4 to -10 on the first iteration and -4 to -7 on the last iteration.

12.4.4 Omit those cycles with $MFB2 < \text{Mean-}M + F \times S$ which are outliers .

Commented [TB52]: 63. see my comment to 12.3.4

12.4.5 If no outliers are found in [12.4.4](#), the process is complete. If outliers are found in 12.4.4, repeat steps 12.4.3.1 through 12.4.4 until no new outliers are found.

12.4.6 Record the total number of outliers from 12.4.1.1 and 12.4.4.

12.5 Report LSPI Cycles.

12.5.1 [An LSPI cycle is defined as any combustion event](#) containing both *PP* and *MFB2* outliers.

Commented [TB53]: 64. This is the first mention of LSPI cycle so we should define it here.

Sequence IX Draft, [April 2018 TWB](#)
(Based on document “Seq IX LSPI Test Method_20180412.docx”)

12.5.2 On Form 11 of the Report Forms (see A12), report the following data for each cylinder for each iteration A through D:

~~12.5.1 Total number of combined LSPI cycles. An LSPI cycle is defined as any combustion event containing both PP and MFB2 outliers.~~

12.5.2.1 Total number of combustion cycles containing only a PP outlier.

12.5.2.2 Total number of combustion cycles containing only a MFB2 outlier.

12.5.2.3 Number of invalid cycles.

12.5.2.4 Final skewness, kurtosis, F values and thresholds for each valid test iteration.

Commented [TB54]: 65.kurtosis and skewness are not on Form 11. Suggest either Form 11 is amended or 12.5.2.5 is revised.
66.

12.6 Record the controlled, monitored and controller area network (CAN) bus data listed in **Table 7** at a rate of 1/see. See Annex A10 for data acquisition addresses for the CAN bus data.

12.6.1 Report CAN bus data for the four iterations A through D (see 11.3) on Forms 9 and 10 of the Report Forms (see A12).

12.7 *Calculation of LSPI Events*—At the end of each 175,000 cycle run, calculate the number of LSPI events as described in this section using the following data from the AVL Indicom combustion software to determine iteration validity; ~~use the following data from the AVL Indicom combustion analysis software to determine iteration validity and calculate the number of LSPI events using the instructions listed in this section.~~

Commented [TB55]: 67.I found this sentence difficult to follow so have revised it. Is it OK?

- a) Maximum pressure (P_{MAX});
- b) Mass fraction burn 2 % (MFB₂);
- c) Pressure minimum voltage (P_{MINV}).

12.7.1 For each iteration A through D on Forms 12 through 15 of the Report Forms, report cylinder number, cycle number, P_{MAX}, MFB₂, and type of combustion event for each abnormal combustion cycle identified in sections 12.3 and 12.4.

12.7.1.1 An abnormal combustion event is defined as follows:

- a) PP only
- b) MFB₂ only
- c) both PP and MFB₂.

Commented [TB56]: 68.Is this what was intended. If not, please revise.

Abnormal Combustion Designations:

- PP - Peak Pressure Only
- MFB₂ - Mass Fraction Burn 2% Only
- PP&MFB₂ - Both Peak Pressure and Mass Fraction Burn 2%

Commented [FM57]: 69.Include definition of abnormal combustion event types.

Sequence IX Draft, [April 2018 TWB](#)

(Based on document “Seq IX LSPI Test Method_20180412.docx”)

12.8 *Calculation of Average Number of Preignition Events, AvPIE*—Report on Form 4 of the Report Form (see Annex A12) the total number of LSPI events for each iteration A through D (see 11.3). Calculate the average number of events for these four iterations and report as *AvPIE*.

Table 7. Recorded Test Points

	Test Point	Units
Controlled	Engine Speed	r/min
	Engine torque	N•m
	Coolant-out temperature	° C
	Oil-gallery temperature	° C
	Air-charge temperature	° C
	Inlet-air temperature	° C
	Inlet-air pressure	kPa (gauge)
	Exhaust back pressure	kPa (absolute)
	Fuel temperature	° C
	Inlet-air humidity	g/kg
	Coolant flow rate	L/min
Monitored	Fuel flow rate	kg/h
	Intake-manifold pressure	kPa (absolute)
	Air-charge pressure	kPa (absolute)
	Barometric pressure	kPa (absolute)
	Oil-gallery pressure	kPa (gauge)
	Oil-head pressure	kPa (gauge)
	Oil-filter-In temperature	° C
	Exhaust temperature	° C
	Crankcase pressure	kPa (gauge)
	Fuel pressure	kPa (gauge)
	Power	kW
	Pre-intercooler air pressure	kPa (absolute)
	Ambient temperature	° C
	Coolant-in temperature	° C
	Coolant-out pressure	kPa (gauge)
	Blowby flow rate	L/min
	Oil-Sump Temperature	° C
	Coolant flow rate	L/min
Equivalence ratio (λ)	unitless	
PCM CAN bus channels	Ignition timing advance for #1 cylinder	°
	Absolute throttle position	%
	Engine-coolant temperature	° C
	Inlet-air temperature	° C
	Equivalence ratio (λ)	unitless
	Absolute load value	%
	Intake-manifold pressure	kPa (absolute)
	Fuel-rail pressure	kPa (gauge)
	Accelerator-pedal position	%
	Boost pressure - raw value	kPa (absolute)
	Turbocharger wastegate duty cycle	%
	Actual intake (A) camshaft position	°
	Actual exhaust (B) camshaft position	°
	Intake (A) camshaft position actuator duty cycle	%
	Exhaust (B) camshaft position actuator duty cycle	%
	Charge-air-cooler temperature	° C
	Cylinder 1 knock/combustion performance count	Count
	Cylinder 2 knock/combustion performance count	Count

Commented [TB58]: 70. Have replaced “lambda” by symbol “λ”

Commented [TB59]: 71. Is gauge correct?

Sequence IX Draft, [April 2018 TWB](#)
(Based on document “Seq IX LSPI Test Method_20180412.docx”)

Cylinder 3 knock/combustion performance count	Count
Cylinder 4 knock/combustion performance count	Count

13. Report

13.1 For reference oil results, use the standardized report form set available from the ASTM TMC¹⁹⁴⁹ and data dictionary for reporting test results and for summarizing operational data (see Annex A12).

Formatted: Footnote Reference, Font: 10 pt

NOTE 9—Report the non-reference oil test results on these same forms if the results are intended to be submitted as candidate oil results against a specification.

13.1.1 Fill out the report forms according to the formats shown in the data dictionary.

13.1.2 Transmit results to the TMC within 5 working days of test completion.

13.1.3 Transmit the results electronically as described in the ASTM Data Communications Committee Test Report Transmission Model (Section 2 — Flat File Transmission Format) available from the ASTM TMC. Upload files via the TMC’s website.

13.2 Report all reference oil test results, whether aborted, invalidated, or successfully completed, to the TMC.

13.3 *Precision of Reported Units*—Use the Practice E29 rounding-off method for critical pass/fail test result data. Report the data to the same precision as indicated in data dictionary.

13.4 In the space provided, note the time, date, test hour, and duration of any shutdown or off-test condition. Document the outcome of all prior reference oil tests from the current calibration sequence that were operationally or statistically invalid.

Downtime is accumulated any time there is an unscheduled shutdown after the engine has been started with the final fill of test oil. Downtime is also accumulated after an hour of any scheduled shutdown, and continues until the engine is started again.

13.5 If a calibration period is extended beyond the normal calibration period length, make a note in the comment section and attach a written confirmation of the granted extension from the

TMC to the test report. List the outcomes of previous runs that may need to be considered as part of the extension in the comment section.

14. Precision and Bias

14.1 Precision:

14.1.1 Test precision is established on the basis of operationally valid reference-oil test results monitored by the TMC.

14.1.2 *Intermediate Precision Conditions*—Conditions where test results are obtained with the same test method using the same test oil, with changing conditions such as operators, measuring equipment, test stands, test engines, and time.

NOTE 10—Intermediate precision is the appropriate term for this test method, rather than repeatability, which defines more rigorous within-laboratory conditions.

14.1.2.1 *Intermediate Precision Limit (ip)*—The difference between two results obtained under intermediate precision conditions that in the long run, in the normal and correct conduct of the test method, exceed the value shown in **Table 8** in only one case in twenty. When only a single test result is available, the intermediate precision limit can be used to calculate a range (test result \pm intermediate precision limit) outside of which a second test result would be expected to fall about one time in twenty.

14.1.3 *Reproducibility Conditions*—Conditions where test results are obtained with the same test method using the same test oil in different laboratories with different operators using different equipment.

14.1.3.1 *Reproducibility Limit (R)*—The difference between two results obtained under reproducibility conditions that would, in the long run, in the normal and correct conduct of the test method, exceed the values in **Table 8** in only one case in twenty. When only a single test result is available, the reproducibility limit can be used to calculate a range (test result \pm reproducibility limit) outside of which a second test result would be expected to fall about one time in twenty.

TABLE 8 Sequence IX Test Precision^A

Quantity, units	Intermediate Precision ^B	Reproducibility ^C
-----------------	-------------------------------------	------------------------------

Sequence IX Draft, [April 2018 TWB](#)
(Based on document “Seq IX LSPI Test Method_20180412.docx”)

	S_p^D	ip	S_R^D	R
Average Number of Preignitions, sqrt(AvPIE+0.5)	0.2 856	0.7997	0.285 6	0.7997

^A These statistics are based on 34 tests conducted on eight stand/engine combinations at three laboratories on ASTM reference oils 220, 221, and 223. They were calculated on March 29, 2017.

^B See 14.1.2.

^C See 14.1.3.

^D S is the standard deviation.

14.2 *Bias*—No estimate of bias for this test method is possible because the performance results for an oil are determined only under specific conditions of the test and no absolute standards exist.

ANNEXES

(Mandatory Information)

A1. ASTM TEST MONITORING CENTER ORGANIZATION

A1.1 *Nature and Functions of the ASTM Test Monitoring Center (TMC)*—The TMC is a non-profit organization located in Pittsburgh, Pennsylvania and is staffed to: administer engineering studies; conduct laboratory inspections; perform statistical analyses of reference oil test data; blend, store, and ship reference oils; and provide the associated administrative functions to maintain the referencing calibration program for various lubricant tests as directed by ASTM Subcommittee D02.B0 and the ASTM Executive Committee. The TMC coordinates its activities with the test sponsors, the test developers, the surveillance panels, and the testing laboratories. Contact TMC through the TMC Director at:

ASTM Test Monitoring Center
6555 Penn Avenue
Pittsburgh, PA 15206-4489
www.astmtmc.cmu.edu

A1.2 *Rules of Operation of the ASTM TMC*—The TMC operates in accordance with the ASTM Charter, the ASTM Bylaws, the Regulations Governing ASTM Technical Committees, the Bylaws Governing ASTM Committee D02, and the Rules and Regulations Governing the ASTM Test Monitoring System.

A1.3 *Management of the ASTM TMC*—The management of the Test Monitoring System is vested in the Executive Committee elected by Subcommittee D02.B0. The Executive Committee selects the TMC Director who is responsible for directing the activities of the TMC.

A1.4 *Operating Income of the ASTM TMC*—The TMC operating income is obtained from fees levied on the reference oils supplied and on the calibration tests conducted. Fee schedules are established by the Executive Committee and reviewed by Subcommittee D02.B0.

A2. ASTM TEST MONITORING CENTER: CALIBRATION PROCEDURES

Sequence IX Draft, [April 2018 TWB](#)
(Based on document “Seq IX LSPI Test Method_20180412.docx”)

A2.1 *Reference Oils*—These oils are formulated or selected to represent specific chemical, or performance levels, or both. They are usually supplied directly to a testing laboratory under code numbers to ensure that the laboratory is not influenced by prior knowledge of acceptable results in assessing test results. The TMC determines the specific reference oil the laboratory shall test.

A2.1.1 *Reference Oil Data Reporting*—Test laboratories that receive reference oils for stand calibration shall submit data to the TMC on every sample of reference oil they receive. If a shipment contains any missing or damaged samples, the laboratory shall notify the TMC immediately.

A2.2 *Calibration Testing:*

A2.2.1 Full-scale calibration testing shall be conducted at regular intervals. These full-scale tests are conducted using coded reference oils supplied by the TMC. It is a laboratory's responsibility to keep the on-site reference oil inventory at or above the minimum level specified by the TMC test engineers.

A2.2.2 *Test Stands Used for Non-Standard Tests*—If a non-standard test is conducted on a previously calibrated test stand, the laboratory shall conduct a reference oil test on that stand to demonstrate that it continues to be calibrated, prior to running standard tests.

A2.3 *Reference Oil Storage*—Store reference oils under cover in locations where the ambient temperature is between -10 °C and +50 °C.

A2.4 *Analysis of Reference Oil*—Unless specifically authorized by the TMC, do not analyze TMC reference oils, either physically or chemically. Do not resell ASTM reference oils or supply them to other laboratories without the approval of the TMC. The reference oils are supplied only for the intended purpose of obtaining calibration under the ASTM Test Monitoring System. Any unauthorized use is strictly forbidden. The testing laboratory tacitly agrees to use the TMC reference oils exclusively in accordance with the TMC's published Policies for Use and Analysis of ASTM Reference Oils, and to run and report the reference oil test results according to TMC guidelines. Additional policies for the use and analysis of ASTM Reference Oils are available from the TMC.

A2.5 *Conducting a Reference Oil Test*—When laboratory personnel are ready to run a reference calibration test, they shall request an oil code via the TMC website.

A2.6 *Reporting Reference Oil Test Results*—Upon completion of the reference oil test, the test laboratory transmits the data electronically to the TMC, as described in Section 7. The TMC reviews the data and contacts the laboratory engineer to report the laboratory's calibration status.

Sequence IX Draft, [April 2018 TWB](#)
(Based on document “Seq IX LSPI Test Method_20180412.docx”)

All reference oil test results, whether aborted, invalidated, or successfully completed, shall be reported to the TMC.

A2.6.1 All deviations from the specified test method shall be reported.

A3. ASTM TEST MONITORING CENTER: MAINTENANCE ACTIVITIES

A3.1 *Special Reference Oil Tests*—To ensure continuous severity and precision monitoring, calibration tests are conducted periodically throughout the year. Occasionally, the majority or even all of the industry’s test stands will conduct calibration tests at roughly the same time. This could result in an unacceptably large time frame when very few calibration tests are conducted. The TMC can shorten or extend calibration periods as needed to provide a consistent flow of reference oil test data. Adjustments to calibration periods are made such that laboratories incur no net loss or gain in calibration status.

A3.2 *Special Use of the Reference Oil Calibration System*—The surveillance panel has the option to use the reference oil system to evaluate changes that have potential impact on test severity and precision. This option is only taken when a program of donated tests is not feasible. The surveillance panel and the TMC shall develop a detailed plan for the test program. This plan requires all reference oil tests in the program to be completed as close to the same time as possible, so that no laboratory/stand calibration status is left pending for an excessive length of time. In order to maintain the integrity of the reference oil monitoring system, each reference oil test is conducted so as to be interpretable for stand calibration. To facilitate the required test scheduling, the surveillance panel may direct the TMC to lengthen and shorten reference oil calibration periods within laboratories such that the laboratories incur no net loss or gain in calibration status. To ensure accurate stand, or laboratory, or both severity assessments, conduct non-reference oil tests the same as reference oil tests.

A3.3 *Donated Reference Oil Test Programs*—The surveillance panel is charged with maintaining effective reference oil test severity and precision monitoring. During times of new parts introductions, new or re-blended reference oil additions, and procedural revisions, it may be necessary to evaluate the possible effects on severity and precision levels. The surveillance panel may choose to conduct a program of donated reference oil tests in those laboratories participating in the monitoring system, in order to quantify the effect of a particular change on severity and precision. Typically, the surveillance panel requests its panel members to volunteer enough reference oil test results to create a robust data set. Broad laboratory participation is needed to provide a representative sampling of the industry. To ensure the quality of the data obtained,

Sequence IX Draft, [April 2018 TWB](#)
(Based on document “Seq IX LSPI Test Method_20180412.docx”)

donated tests are conducted on calibrated test stands. The surveillance panel shall arrange an appropriate number of donated tests and ensure completion of the test program in a timely manner.

A3.4 Intervals Between Reference Oil Tests—Under special circumstances, such as extended downtime caused by industry-wide parts or fuel shortages, the TMC may extend the intervals between reference oil tests.

A3.5 Introducing New Reference Oils—Reference oils produce various results. When new reference oils are selected, participating laboratories will be requested to conduct their share of tests to enable the TMC to recommend industry test targets. ASTM surveillance panels require a minimum number of tests to establish the industry test targets for new reference oils.

A3.6 TMC Information Letters—Occasionally it is necessary to revise the test method, and notify the test laboratories of the change, prior to consideration of the revision by Subcommittee D02.B0. In such a case, the TMC issues an Information Letter. Information Letters are balloted semi-annually by Subcommittee D02.B0, and subsequently by D02. By this means, the Society due process procedures are applied to these Information Letters.

A3.6.1 Issuing Authority—The authority to issue an Information Letter differs according to its nature. In the case of an Information Letter concerning a part number change which does not affect test results, the TMC is authorized to issue such a letter. Long-term studies by the surveillance panel to improve the test procedure through improved operation and hardware control may result in the issuance of an Information Letter. If obvious procedural items affecting test results need immediate attention, the test sponsor and the TMC issue an Information Letter and present the background and data supporting that action to the surveillance panel for approval prior to the semiannual Subcommittee D02.B0 meeting.

A3.7 TMC Memoranda—In addition to the Information Letters, supplementary memoranda are issued. These are developed by the TMC and distributed to the appropriate surveillance panel and participating laboratories. They convey such information as batch approvals for test parts or materials, clarification of the test procedure, notes and suggestions of the collection and analysis of special data that the TMC may request, or for any other pertinent matters having no direct effect on the test performance, results, or precision and bias.

A4. ASTM TEST MONITORING CENTER: RELATED INFORMATION

Sequence IX Draft, [April 2018 TWB](#)
(Based on document “Seq IX LSPI Test Method_20180412.docx”)

A4.1 *New Laboratories*—Laboratories wishing to become part of the ASTM Test Monitoring System will be requested to conduct reference oil tests to ensure that the laboratory is using the proper testing techniques. Information concerning fees, laboratory inspection, reagents, testing practices, appropriate committee membership, and rater training can be obtained by contacting the TMC Director.

A4.2 *Information Letters: COTCO Approval*—Authority for the issuance of Information Letters was given by the committee on Technical Committee Operations in 1984, as follows: “COTCO recognizes that D02 has a unique and complex situation. The use of Information Letters is approved providing each letter contains a disclaimer to the effect that such has not obtained ASTM consensus. These Information Letters should be moved to such consensus as rapidly as possible.”

A4.3 *Precision Data*—The TMC determines the precision of test methods by analyzing results of calibration tests conducted on reference oils. Precision data are updated regularly. Current precision data can be obtained from the TMC.

A5. CONTROL AND DATA ACQUISITION REQUIREMENTS

A5.1 *General Description:*

A5.1.1 The data acquisition system shall be capable of logging the operational data in digital format. It is to the advantage of the laboratory that the system be capable of real time plotting of controlled quantities to help assess test validity. The systems shall be capable of calculating real time quality index as this will be monitored throughout the test as designated in [A5.4](#).

A5.1.2 Control capability is not dictated by this procedure. The control system shall be capable of keeping the controlled quantities within the limits specified in [Table 6](#) and maintain the quality index shown in [A5.4](#).

A5.1.3 Design the control and data acquisition system to meet the requirements listed below. Use the recommendations laid out in the Instrumentation Task Force Report and Data Acquisition Task Force Report for any items not addressed in [Annex A3](#).

A5.2 *Digital Recording Frequency*—The maximum allowable time period over which data can be accumulated is 1 s. This data can be filtered, as described in [A5.5](#), and will be considered a reading.

A5.3 *Steady State Operation:*

A5.3.1 Each test interval of 175,000 engine cycles is conducted at steady state operation. Calculate the quality index using values reported to the accuracy levels in [Table A5.1](#).

Sequence IX Draft, [April 2018 TWB](#)
(Based on document "Seq IX LSPI Test Method_20180412.docx")

TABLE A5.1 Accuracy Levels of Data Points to be Used in QI Calculations

Quantity	Field Length
Speed	
Humidity	
Temperature	
Load	
Inlet Air Pressure	
Exhaust Backpressure	
Fuel Flow	

Commented [TB60]: 72.Do we not need entries in this column?

Sequence IX Draft, [April 2018 TWB](#)
 (Based on document "Seq IX LSPI Test Method_20180412.docx")

TABLE A5.2 L and U Constants and Over- and Under-Range Values

Quantity, unit	L	U	Over-range	Under-range
Speed, r/min	1730	1770		
Torque, N•m	264	274		
Coolant out temperature, °C	94.5	95.5		
Oil gallery Temperature, °C	94.5	95.5		
Air charge temperature, °C	42.5	43.5		
Inlet air temperature, °C	29.5	30.5		
Fuel temperature, °C	29.5	50.5		
Back pressure, kPa (absolute)	102	106		
Inlet air pressure, kPa (absolute)	0.03	0.07		
Humidity, g/kg	10.9	11.9		
Coolant pressure, kPa (gauge)	68	72		
Coolant flow rate, L/min	53	57		

Commented [TB61]: 73.Please provide the values

TABLE A5.3 Maximum Allowable Time Constants

Control Quantity	Time Constant, s
Engine speed, r/min	0.5
Torque, N•m	0.7
Engine oil in, °C	2.4
Engine coolant out, °C	2.4
Engine coolant flow, L/min	8.0
Blowby in, °C	2.4
Inlet air temperature, °C	2.4

Sequence IX Draft, [April 2018 TWB](#)
 (Based on document "Seq IX LSPI Test Method_20180412.docx")

Control Quantity	Time Constant, s
Inlet air pressure, kPa	1.2
Exhaust back pressure, kPa	1.2
Engine coolant pressure, kPa	1.2

A5.3.2 The time intervals between recorded readings shall not exceed 1 s. Data shall be recorded throughout the length of each test iteration.

A5.4 Quality Index Calculation:

A5.4.1 In accordance with the DACA II Report II calculate the quality index, *QI*, for all controlled quantities for the steady state portion of each test stage throughout the entire test. Ensure missing or bad quality data are accounted for in accordance with the DACA II Report.

A5.4.2 Update the quality index periodically throughout the test to determine the operational validity while the test is in progress. This could indicate if the test operational validity is in question before the test has completed.

A5.4.3 Use the following equation and the values listed in [Table A5.2](#) to calculate the *QI*.

$$1 - \frac{1}{n} \sum_{i=1}^n \left(\frac{U+L - 2X_i}{U-L} \right)^2 = \text{Quality index} \quad (\text{A2.1})$$

where:

X_i = values of the quantity measured,

U = allowable upper limit of X ,

L = allowable lower limit of X , and

n = number of measurements taken.

A5.4.4 Reset data that is greater than the over-range values listed in [Table A5.2 \(TBD\)](#) with the over-range value listed in [Table A5.2 \(TBD\)](#).

A5.4.5 Reset data that is lower than the under-range values listed in [Table A5.2 \(TBD\)](#) with the under-range value listed in [Table A5.2 \(TBD\)](#).

A5.4.6 Round the *QI* values to the nearest 0.001.

Commented [TB62]: 74.Values required in Table A5.2

Sequence IX Draft, [April 2018 TWB](#)
(Based on document "Seq IX LSPI Test Method_20180412.docx")

A5.4.7 Report the Q_i values on [Forms 5 to 8](#) of the test report.

A5.4.8 If the end-of-test Quality index value is below 0.000 for reference oil tests, review the test operations with the TMC. The TMC issues a letter to the laboratory and the test sponsor on its opinion.

A5.4.8.1 The laboratory documents its comments regarding the end-of-test Quality index values less than 0.000 for non-reference oil tests. The laboratory or test sponsor might request TMC review of test operations for non-reference oil tests. The TMC issues a letter to document its opinion.

A5.5 *Time Constants:*

A5.5.1 Filtering can be applied to all control quantities. The amount of filtering applied shall not allow time constants to exceed the values listed in [Table A5.3](#). This time constant shall pertain to the entire system, running from the sensor to the display and data acquisition.

A5.5.2 Maximum allowable system time constants for the controlled quantities are shown in [Table A7.3](#).

Annex A6. TEMPERATURE, PRESSURE AND OTHER CONTROL SYSTEMS

A6.1 See Figs. A6.1 to A6.17.

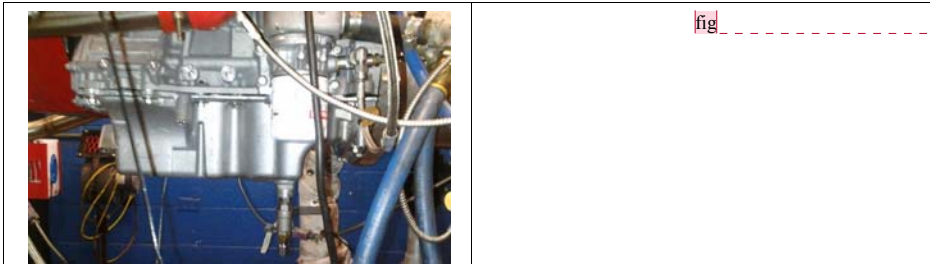

Commented [FM63]: 75.LZ modified oil pan pic to go here
TWB: Please provide pic.

FIG. A6.1 Oil Pan Drain Locations

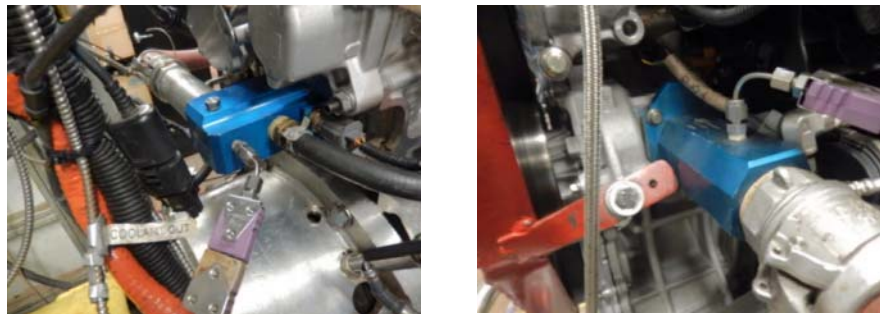
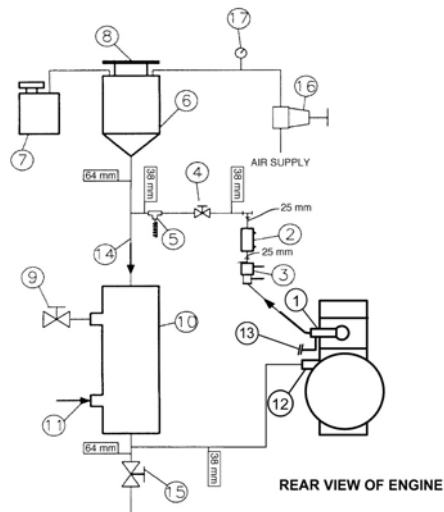

FIG. A6.2 Coolant Out And In Connections And Thermocouple Locations

Commented [FM64]: 76.Show names



Locate the temperature sensors in the thermostat housing and at water pump inlet as shown in 1 and 12 respectively.

Sequence IX Draft, [April 2018 TWB](#)
(Based on document "Seq IX LSPI Test Method_20180412.docx")

- (1) Thermostat housing, coolant out with temperature sensor (P/N OHTVH-009-1)
- (2) Sight glass
- (3) Flowmeter (can be installed on the inlet or outlet sides of the engine, outlet installation shown here)
- (4) Flow control valve
- (5) Optional temperature sensor
- (6) Fabricated coolant reservoir
- (7) Constant full expansion tank
- (8) Pressure radiator cap (MOTORCRAFT RS40 P/N D2YY-8100-A)
- (9) Process water control valve (regulated by temperature controller with three remote set points)
- (10) Heat exchanger (ITT Standard P/N 5-030-06-048-001 TYP.) (Run engine coolant through the tube side)
- (11) Process water supply (shell side)
- (12) Water pump inlet with temperature sensor (OHTVH-008-1)
- (13) Turbocharger coolant return
- (14) Engine coolant (tube side)
- (15) Coolant system drain valve
- (16) Coolant pressure regulator
- (17) Coolant pressure

FIG. A6.3 Schematic Showing Components Of A Of Typical Engine Cooling System

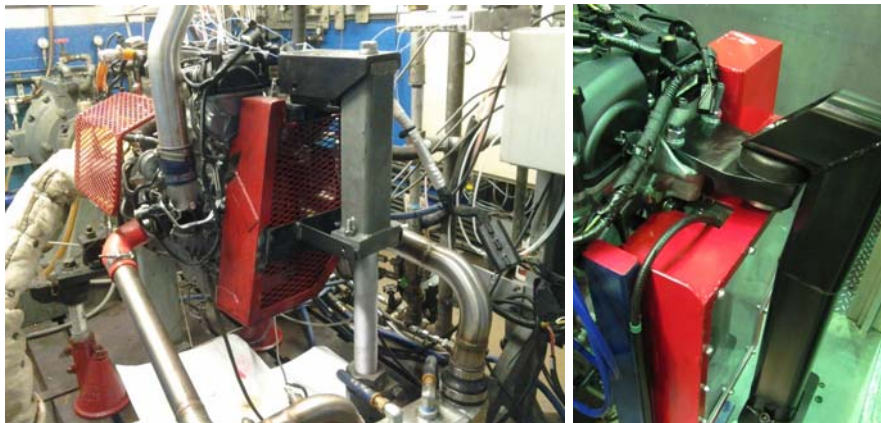

FIG. A6.4 Motor Mount, Front (Two Options Shown)

Sequence IX Draft, [April 2018 TWB](#)
(Based on document "Seq IX LSPI Test Method_20180412.docx")

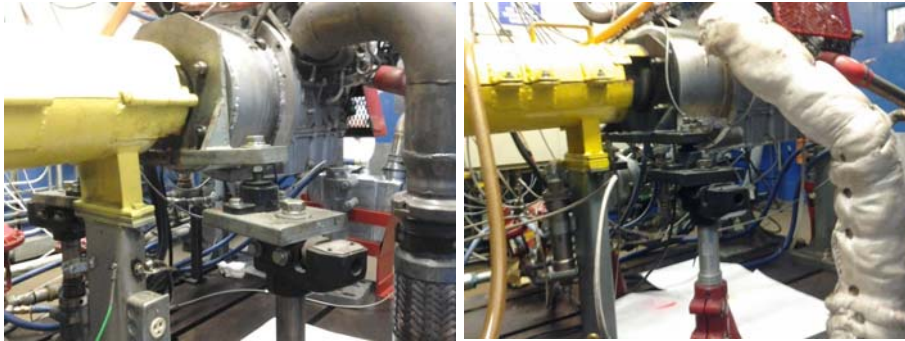

FIG. A6.5 Motor Mount, Rear

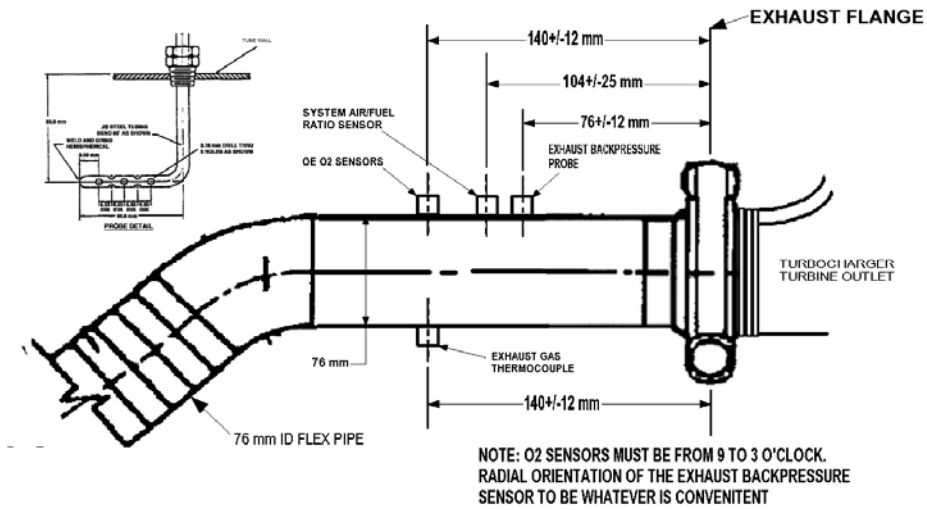

FIG. A6.6 Exhaust Measurements and Instrumentation

Sequence IX Draft, [April 2018 TWB](#)
(Based on document "Seq IX LSPI Test Method_20180412.docx")

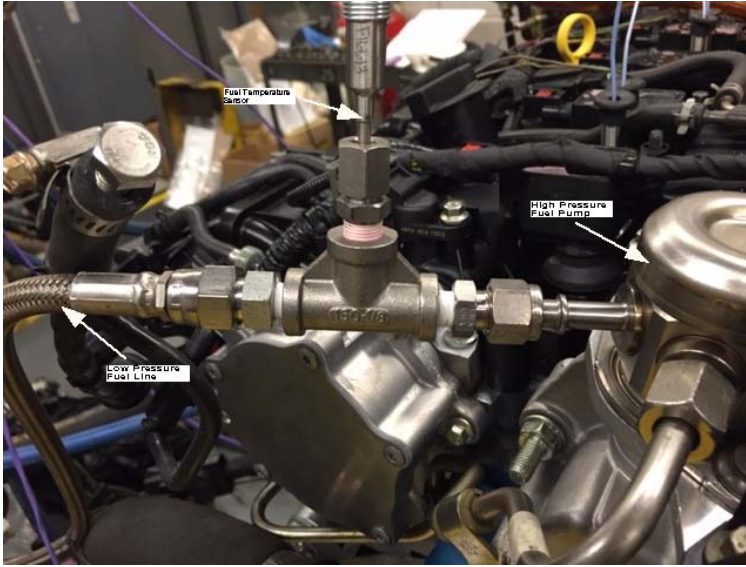

FIG. A6.7 Location of Fuel-Temperature Sensor

Sequence IX Draft, [April 2018 TWB](#)
(Based on document "Seq IX LSPI Test Method_20180412.docx")

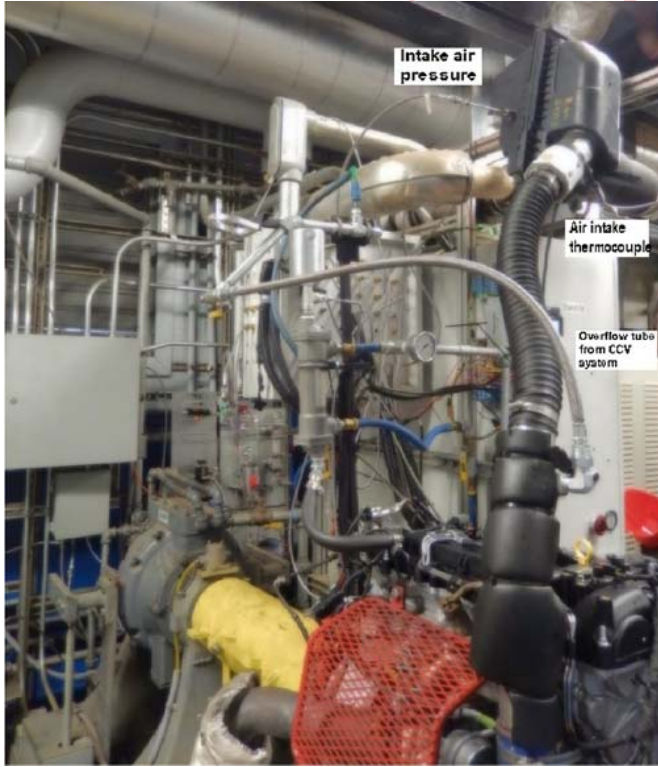

FIG. A6.8 Typical Air Inlet System

Commented [FM65]: Update to show correct temp and press locations

TWB: Please provide updated fig.

Sequence IX Draft, [April 2018 TWB](#)
(Based on document "Seq IX LSPI Test Method_20180412.docx")

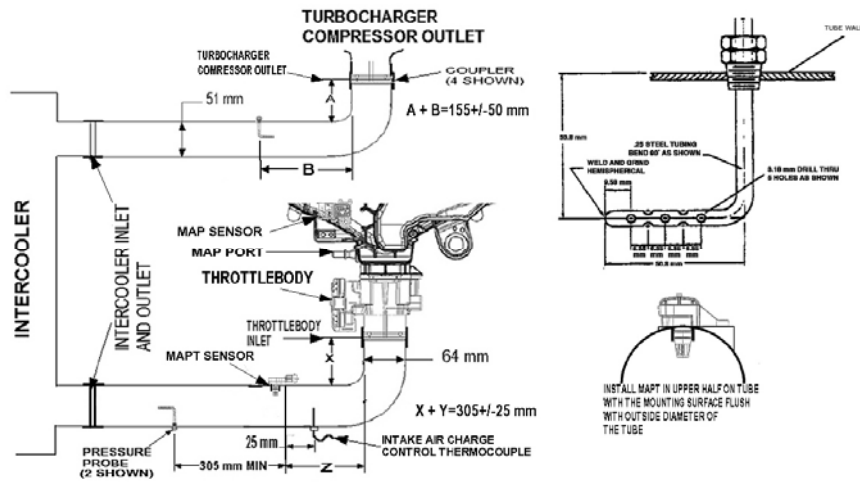

FIG. A6.9: Intercooler Tubing Measurements and Instrumentation

Sequence IX Draft, [April 2018 TWB](#)
(Based on document "Seq IX LSPI Test Method_20180412.docx")

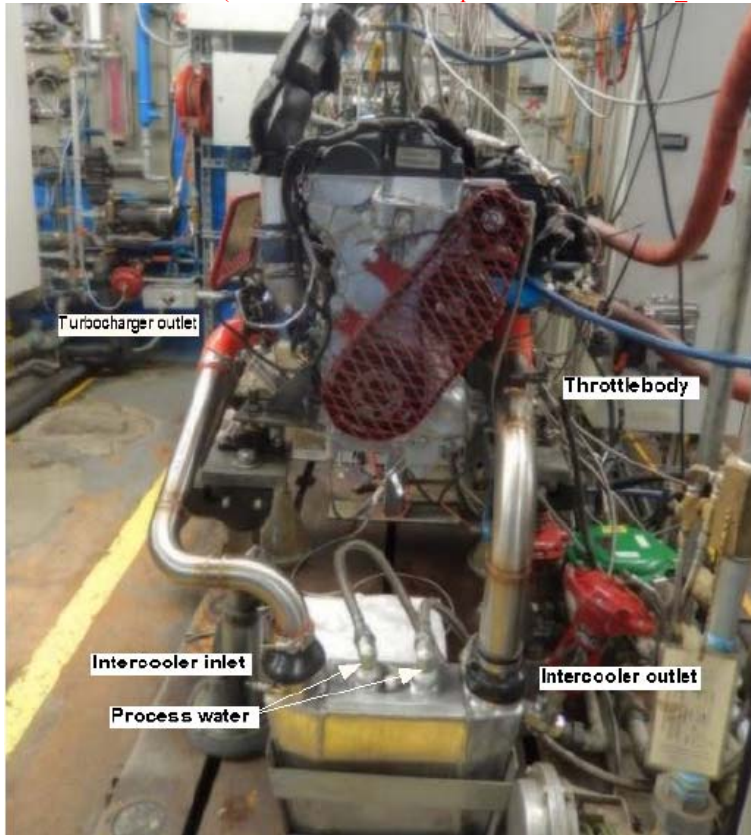

FIG. A6.10 Typical Intercooler Installation

Sequence IX Draft, [April 2018 TWB](#)
(Based on document "Seq IX LSPI Test Method_20180412.docx")



Fig. A6.11 Oil Cooler Showing Oil Gallery Pressure Sensor Location

Sequence IX Draft, [April 2018 TWB](#)
(Based on document "Seq IX LSPI Test Method_20180412.docx")

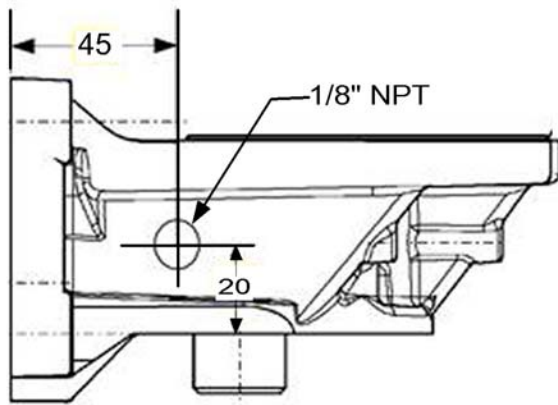

Oil Out temperature location in oil filter adapter

FIG. A6.12 Oil Cooler Showing Oil Temperature Locations

Sequence IX Draft, [April 2018 TWB](#)
(Based on document "Seq IX LSPI Test Method_20180412.docx")

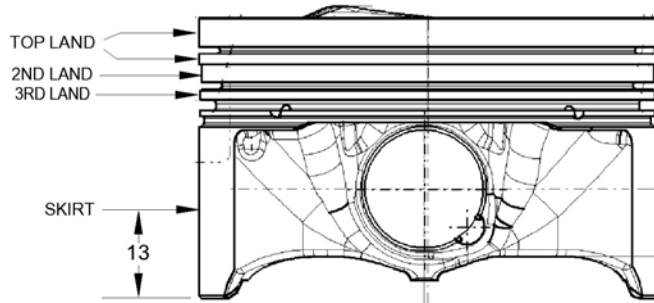

Fig. A6.13 Piston Diameter Measurements

A6.14. Bore Ladder

Commented [TB66]: 77. There is no Fig for bore ladder in the original draft – see 8.4.1.1 Please supply.

Sequence IX Draft, [April 2018 TWB](#)
(Based on document "Seq IX LSPI Test Method_20180412.docx")

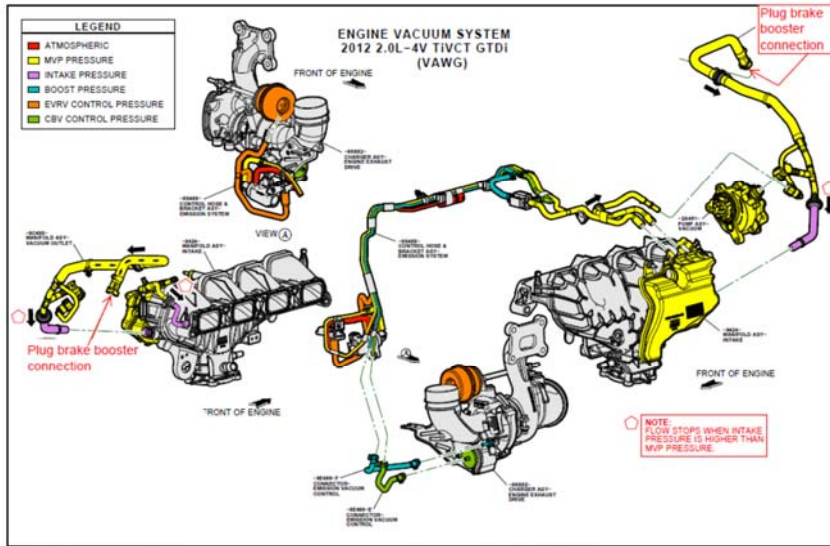

FIG. A6.15 Vacuum System

Commented [TB67]: 78. This fig is not mentioned in the text. Please provide appropriate text in relevant section.
79. Note: Thus this is Fig A2.19 in original draft 20170505.

FIG. A6.16 Dynamometer Wiring Harness

FIG. A6.17 Engine Wiring Harness

Commented [TB68]: 80. The text 7.15.1 refers to Figs A6.16 and A6.17 for diagrams of wiring harness identifying connections. Please supply these diagrams:

Note: These are referred to as Figs A2.20 and A2.21 in the original LSPI 20170505 draft but there are no such Figs in this draft.
81.

Sequence IX Draft, [April 2018 TWB](#)
 (Based on document "Seq IX LSPI Test Method_20180412.docx")

ANNEX A7 TEST FUEL SPECIFICATION

A7.1 See Table A7.1

Table A7.1 Test Fuel Specification

Quantity, units	Test method	Specification
Research octane number	D2699	96.0 to 98.5
Octane number sensitivity	D2700	7.5 to 10.5
Lead concentration, mg/L	D3237	≤ 2.5
Total sulfur mass fraction, mg/kg	D2622, D3120, D5453	≤ 15
Phosphorus concentration, mg/L	D3231	≤ 1.3
Copper corrosion (3 h at 50 °C) (dark orange)	D130	≤ 1b
Oxidation stability, min	D525	≥ 1000
Specific gravity, kg/L *	D1298	0.734 to 0.744
Hydrocarbon Composition	D1319	
Aromatics, volume fraction, %		25 to 35
Olefins, volume fraction, %		≤ 10
Saturates, volume fraction, %		remainder
Gum concentration (washed), mg/100 mL	D381	≤ 4
Gum concentration (unwashed), mg/100 mL		≤ 10
Reid Vapor Pressure, kPa *	D323	60 to 63
Distillation * percentages to be evaporated within temperatures shown below:	D86	
IBP, °C		24 to 35
10 %, °C		49 to 57
50 %, °C		93 to 110
90 %, °C		149 to 163
End Point, °C		≤ 213
Residue volume fraction, %		≤ 2
Water and sediment, % *	D2709	≤ 0.01

Sequence IX Draft, [April 2018 TWB](#)
(Based on document "Seq IX LSPI Test Method_20180412.docx")

Odor		Shall have the usual characteristic odor of gasoline with no pronounced foreign odor. Shall have the usual characteristic odor of gasoline with no pronounced foreign odor. Shall have the usual characteristic odor of gasoline with no pronounced foreign odor
Color		Red

Sequence IX Draft, [April 2018 TWB](#)
 (Based on document "Seq IX LSPI Test Method_20180412.docx")

Annex A8. PART NUMBERS FOR ENGINE ASSEMBLY, ENGINE PARTS, FASTENERS, GASKETS, TEST STAND SETUP PARTS, AND SPECIAL PARTS

A8.1 See Tables A8.1 to A8.8.

TABLE A8.1 Engine Assembly Part Numbers

Current Ford Service P/N	Current Ford Engineering	Description
BB5Z-6006-A	BB5E-6006-AD	2.0L ENGINE ASY LB
	DA8E-6006-BB	2.0L ENGINE ASY LB

TABLE A8.2 Reusable Engine Parts

Current Ford Service P/N	Current Ford Engineering	Description
BB5Z9F593B	BB5E9F593BA	INJECTOR ASY
CJ5Z9D280A	CJ5E9D280BF	MANIFOLD ASY - FUEL SUPPLY
CJ5Z9D440A	CJ5E9B374BC	COVER - FUEL PUMP

TABLE A8.3 Part Numbers for Fasteners

Current Ford Service P/N	Current Ford Engineering	Description
W500033S437	W500033S437	BOLT - FLANGED HEX.
W500114S442	W500114S442	BOLT
W500212S437	W500212S437	SCREW
W500214S437	W500214S437	BOLT - HEX.HEAD
W500221S437	W500221S437	BOLT - HEX.HEAD
W500224S437	W500224S437	BOLT
W500300S437	W500300S437	BOLT
W500301S437	W500301S437	BOLT
W500310S437	W500310S437	BOLT - HEX.HEAD
W500313S437	W500313S437	BOLT
W500328S437	W500328S437	BOLT
W500414S442	W500414S442	BOLT
W503275S437	W503275S437	BOLT - HEX. HEAD - FLANGED
W505531S442	W505531S442	SCREW
W506976S442	W506976S442	SCREW
W520214S440	W520214S440	NUT
W700115S437	W700115S437	SCREW AND WASHER ASY
W701183S300	W701183S300	DOWEL - BUSH
W701219S437	W701219S437	BOLT
W702426S303	W702426S303	BOLT - HEX.HEAD
W702492S437	W702492S437	STUD
W702700S437	W702700S437	STUD
W703383S437	W703383S437	BOLT
W703643S430	W703643S430	BOLT
W703649S300	W703649S300	PIN
W704474S437	W704474S437	STUD

Sequence IX Draft, [April 2018 TWB](#)
 (Based on document "Seq IX LSPI Test Method_20180412.docx")

W706282S430	W706282S430	BOLT
W706284S437	W706284S437	BOLT
W706487S437	W706487S437	BOLT-OIL COOLER FILTER
W711261S437	W711261S437	BOLT
W711574S439	W711574S439	STUD
W712022S430A	W712022S430	BOLT - HEX.HEAD
W713095S403	W713095S403	NUT
W715323S300	W715323S300	WASHER - COPPER, T/C OIL LINE
W715638S443	W715638S443	STUD
W716137S437	W716137S437	BOLT
W716735S437	W716735S437	BOLT
W716841S900	W716841S900	PIN, BELL HOUSING
1L5Z6379AA	W706161S300	BOLT
1S7Z6A340AA	1S7G6K340BC	BOLT, CRK SHFT PULLEY
1S7Z6K282AA	1S7G6K282AB	BOLT, CHAIN TEN
AG9Z6065A	AG9G6065BA	BOLT - HEX.HEAD, CYL HEAD
AG9Z6345A	AG9G6345AC	BOLT - BEARING CAP - HEX. HEAD
BB5Z6214A	BB5E6214CA	BOLT - CONNECTING ROD
CV6Z6279A	CV6E6279AA	BOLT, CAMSHAFT

Sequence IX Draft, [April 2018_TWB](#)
 (Based on document "Seq IX LSPI Test Method_20180412.docx")

TABLE A8.4 Part Numbers for Test Parts

Current Ford Service P/N	Current Ford Engineering	Description
7T4Z9601A	7T439601AA	ELEMENT ASY - AIR CLEANER
1S7Z6378AA	1S7G6378AB	WASHER,CRK DIAMOND CRUSH
6M8Z6278A	6M8G6278AA	WASHER, CAM, DIAMOND CRUSH

TABLE A8.5 Part Numbers for Gaskets

Current Ford Service P/N	Current Ford Engineering	Description
CJ5Z6079D	CJ5E6079AC	KIT - GASKET
1S7Z6571EA	1S7G6A517BG	SEAL - VALVE STEM EX
1S7Z6840AA	1S7G6A636AD	GASKET, OIL FILTER ADPT
1S7Z6K301BA	1S7G6A321AA	SEAL - CRANKSHAFT REAR OIL
1S7Z8507AE	1S7G8507AF	GASKET - WATER PUMP
3M4Z6625AA	3M4G6625AA	GASKET, OIL PMP P/U TUBE
3M4Z8255A	3M4G8K530AB	GASKET, T/STAT HSG
3S4Z6571AA	3S4G6A517AA	SEAL - VALVE STEM INT
9L8Z9E936A	9L8E9E936AA	GASKET, T/B
AA5Z9E583A	AA5E9E583AA	SEAL, FU PUMP
AG9Z9P431A	AG9G9P431AA	GASKET, T/C COOL LINE
BB5Z2A572B	BB5E2D224BB	GASKET - VACUUM PUMP
BB5Z6584A	BB5E6K260AB	GASKET, CAM COVER
BB5Z6L612A	BB536L612AA	GASKET, EXHAUST
BG9Z9229A	BG9E9U509AB	KIT - "O" RING, FU INJ
BR3Z6C535B	BR3E6P251BA	SEAL - VALVE VCT
CB5Z9276A	CJ5E9A420BA	GASKET, FU PUMP CVR
CJ5Z6051A	CJ5E6051EC	GASKET - CYLINDER HEAD
CJ5Z6N652A	CJ5E6N652AA	GASKET, T/C OIL DRAIN LINE
CJ5Z8255A	CJ5E8255AA	SEAL - THERMOSTAT
CJ5Z9439A	CJ5E9439AA	GASKET - INTAKE MANIFOLD
CJ5Z9448A	CJ5E9448BA	GASKET, EX MANIFOLD
CM5Z6700A	CM5E6700AB	SEAL ASY - CRKS HAFT OIL - FRT

Sequence IX Draft, [April 2018_TWB](#)
 (Based on document "Seq IX LSPI Test Method_20180412.docx")

Table A8.6 Test Stand Setup Part Numbers

Current Ford Service P/N	Current Ford Engineering	Description
AG9Z9D930B	AG9T9H589BE	WIRE ASY, FE INJ
1S7Z12A699BB	1S7A12A699BB	SENSOR - ENGINE KNOCK
6M8Z6C315AA	6M8C6C315AB	SENSOR - CRANKSHAFT POSITION - CPS
8F9Z9F472A	8F9A9Y460AB	SENSOR ASY, O ₂
8V2Z12B579A	8V212B579AA	SENSOR ASY, MAF
9L8Z6G004E	9L8A6G004BC	SENSOR ASY, CYL HD TMP
AA5Z9A600B	AA539A600AD	CLEANER ASY - AIR
AE5Z6A228A	AE5Q6A228AA	PULLEY ASY - TENSION BELT
AE5Z8620A	AE5Q6C301AA	V-BELT
AG9Z6K679A	AG9G6K679BC	PIPE - OIL FEED, T/C
AG9Z6K868A	CJ5E6K868AA	VALVE ASY, ENG PST OIL COOL
AG9Z6L092A	AG9G6K677BC	HOSE - T/C OIL DRAIN
AG9Z8555A	AG9C8A506BB	HOSE - WATER INLET, T/C
AG9Z9F479A	AG919F479AB	SENSOR ASY, MAP
BV6Z9F479A	BV619F479AA	SENSOR ASY, MAPT
AS7Z6B288A	AS7112K073AA	SENSOR - CAMS HAFT POSITION
BB3Z6A642A	BB3E6A810AA	KIT ENGINE OIL COOLER
BB5Z11002C	BB5T11000AA	STARTER MOTOR ASY
BB5Z5A231A	BB535A281AA	CLAMP - HOSE, T/C TO EXH
BB5Z6C640A	BB536K863CE	CONNECTION - AIR INLET T/B END
BB5Z6C640B	BB536K863DF	CONNECTION - AIR INLET, I/C END
BB5Z6C646C	BB536C646CD	DUCT - AIR, TURBO END
BB5Z6C646D	BB536C646DF	DUCT - AIR, INTERCOOLER END
BB5Z6C683A	BB5E6L663AA	FILTER ASY (T/C SCREEN)
BB5Z9647A	BB539647AB	BRACKET, AIRBOX
BB5Z9661A	BB539643AA	COVER, AIRBOX
BB5Z9B659B	BB539F805DE	HOSE - AIR, TURBO END
BB5Z9B659E	BB539F805CG	HOSE - AIR, AIR BOX END
BM5Z9F972A	BM5G9F972BA	SENSOR - FUEL INJECTOR PRESSURE
BR2Z9E499A	BR2E9E499AA	CONNECTOR, VAC CONTRL, T/C
CB5Z6K682F	CB5E6K682BF	TURBO CHARGER
CB5Z8592A	CB5E8592AB	CONNECTION - WATER OUT, T/C
CB5Z8K153B	CB5E8B535AC	TUBE - WATER OUTLET
CB5Z9424D	CB5E9424AF	MANIFOLD ASY - INTAKE
CB5Z9S468C	CB5E9S468AF	HOSE, EMS (VAC HARNESS)
CJ5Z9J323B	CJ5E9J323BC	TUBE ASY FE PMP TO FE MAN
CM5Z12029A	CM5E12A366CA	COIL ASY - IGNITION
CP9Z9E926A	CM5E9F991AD	THROTTLE BODY AND MOTOR ASY
D4ZZ7600A	D4ZA7120AB	SLEEVE, PILOT BEARING
DU5Z12A581U	DU5T12C508UE	WIRE ASY, ENGINE MAIN
YS4Z6766A	YS4G6766DA	CAP ASY - OIL FILLER
5M6Z8509AE	5M6Q8509AE	PULLEY - WATER PUMP
AG9Z6312B	AG9E6D334AA	PULLEY - CRANKSHAFT

TABLE A8.7 Part Numbers for Special Parts

DESCRIPTION ^A	P/N
Housing, flywheel	OHTVH-005-1
Flywheel, modified, 2.0l	OHTVH-006-1
Clutch (Sachs)	K0047-07
Plate, Pressure	VH006-8-2
Harness, Dyno, 2.0l	OHTVH-007-1
Inlet, Coolant	OHTVH-008-1
Clip, Retainer, Sensor, Coolant Inlet	VH008-1
Seal, Coolant Inlet	VH008-2
Outlet, Coolant	OHTVH-009-1
Seal, Coolant Outlet	VH009-6
Spacer (Shim), Clutch Pressure Plate	OHTVH-011-1
Cylinder Head, Instrumented	TEI
Mount, Front, Ford 2.0l	OHTVH-004-1
Rubber Isolator, Front Mount	85 ESCORT
Rubber Isolator, Rear Mount	6628-A
Pressure Transducer,	AVL

Commented [TB69]: 82.Is there a P/N other than TEI

Commented [TB70]: 83.What is the P/N other than AVL.

Commented [TB71]: 84.Please confirm that all parts are available from OHT, including the Sachs clutch, the TEI-modified cylinder head, and the AVL Pressure transducer

^A All parts are available from OH Technologies, 9300 Progress Pkwy, Mentor, OH 44060.

Sequence IX Draft, [April 2018_TWB](#)
(Based on document "Seq IX LSPI Test Method_20180412.docx")

Table A8.8 Service Tools

Tool name	Supplier	P/N
Camshaft alignment tool		
Timing peg		
Crankshaft position sensor alignment tool		
Pressure sensor installation tool		

Commented [TB72]: 85. Who are the suppliers? –ref 8.9 which says Table A8.8 describes the tool

Commented [TB73]: 86. What are the P/Ns?

A9. ENGINE MEASUREMENTS

A9.1 Cylinder Bore and Piston Measurements—See Table A9.1.

Table A9.1 Cylinder Bore and Piston Measurement Record

Block # / Run # :
 Tech:

Date: Test Number:

Cylinder bore measurements without out stress plate

Finish target Roughness (Ra) 0.225 μ m to 0.325 μ m
 Bore gauge set: 87.5 mm

Piston to wall clearance: 0.0225 mm to 0.0475 mm
 Cylinder cross hatch target: 25° to 35°

Cylinder bore diameter and surface finish

Cylinder number	Location	Longitudinal diameter,	Transverse diameter,	Surface finish, Ra
1	Top			
	Middle			
	Bottom			
	Average			
2	Top			
	Middle			
	Bottom			
	Average			
3	Top			
	Middle			
	Bottom			
	Average			
4	Top			
	Middle			
	Bottom			
	Average			

Use bore ladder

Piston to Bore Clearance

Cylinder Number		Piston Diameter		Piston Clearance	
		Longitudinal, mm	Transverse, mm	Longitudinal, mm	Transverse, mm
1	Top land				
	2nd land				
	3rd land				
	Skirt				
2	Top land				
	2nd land				
	3rd land				
	Skirt				
3	Top land				
	2nd land				
	3rd land				
	Skirt				
4	Top land				
	2nd land				
	3rd land				
	Skirt				

Top land is the ring land above upper compression ring
 2nd land is the ring land between upper and lower compression rings
 3rd land is the ring land between lower compression and oil rings
 Skirt is 13 mm to 15 mm up from the bottom of the piston skirt

Ring Gap

Cylinder Number	Top ring,	Second ring,
1		
2		
3		
4		

Ring side clearance

Cylinder Number		Clearance, mm				Average
		At 0°	At 90°	At 180°	At 270°	
1	UCR					
	LCR					
2	UCR					
	LCR					
3	UCR					
	LCR					
4	UCR					
	LCR					

Cross Hatch Measurement

Cylinder Number	Meas# 1 (degrees)	Meas# 2 (degrees)	AVG Cross Hatch (degrees)
1			
2			
3			
4			

Commented [TB74]: 87. Have inserted “Ra”. Is that correct?

Commented [TB75]: 88. Have inserted mm. Is that correct?

Commented [TB76]: 89. What are the units for cross hatch measurement?

Sequence IX Draft, [April 2018 TWB](#)
 (Based on document “Seq IX LSPI Test Method_20180412.docx”)

thickness and groove height for side clearance calculation

Ring Tension

Cylinder	Top Ring	Second Ring
1		
2		
3		
4		

Cylinder Number		Δt_0	Δt_{90°	(mm)	(mm)
		(mm)	(mm)		
1	UCR Thickness				
	UCR Groove height				
	LCR Groove height				
	LCR Thickness				
2	UCR Thickness				
	UCR Groove height				
	LCR Groove height				
	LCR Thickness				
3	UCR Thickness				
	UCR Groove height				
	LCR Groove height				
	LCR Thickness				
4	UCR Thickness				
	UCR Groove height				
	LCR Groove height				
	LCR Thickness				

Measure the ring side clearance either:
 with a thickness gauge between the ring and ring groove with the ring installed;
 or by calculating the difference between the thickness
 of the ring and the height of the ring groove with the ring uninstalled.
 Take four measurements 90° apart.

Commented [TB77]: 90.What are the units for ring tension?

A9.2 Cylinder Head Measurements—See Table A9.2.

Table A9.2 Cylinder Head Measurements Record

Head # _____
 Head Run # _____
 DATE: _____

Engine # _____
 Test # _____
 Instrument Cntrl # (Valve Guide) _____
 Instrument Cntrl # (Valve Stem) _____

	Valve guide diameter (5.51) mm	Valve stem diameter (5.5) mm	Clearance (0.03 to 0.07) mm
1A intake			
1B intake			
2A intake			
2B intake			
3A intake			
3B intake			
4A intake			
4B intake			

	Valve guide diameter (5.51) mm	Valve stem diameter (5.5) mm	Clearance (0.03 to 0.07) mm
1A exhaust			
1B exhaust			
2A exhaust			
2B exhaust			
3A exhaust			
3B exhaust			
4A exhaust			
4B exhaust			

Commented [TB78]: 91. Why are there numbers in parenthesis in headings. Are they targets, perhaps?

Instrument cntrl # (length) _____

	Spring free length (47 mm)	Spring tension (kg @ 28.5 mm)
1A intake		
1B intake		
2A intake		
2B intake		

Instrument cntrl # (tension) _____

	Spring free length (47 mm)	Spring tension (kg @ 28.5 mm)
1A exhaust		
1B exhaust		
2A exhaust		
2B exhaust		

Commented [TB79]: 92. Is this a target?

Commented [TB80]: 93. Is this a target?

Sequence IX Draft, [April 2018_TWB](#)
 (Based on document "Seq IX LSPI Test Method_20180412.docx")

3A intake		
3B intake		
4A intake		
4B intake		

3A exhaust		
3B exhaust		
4A exhaust		
4B exhaust		

Instrument cntrl # (lash) _____

Intake valve lash measurement (0.19 to 0.31) mm	
1F	
1R	
2F	
2R	
3F	
3R	
4F	
4R	

Exhaust valve lash measurement (0.30 to 0.42) mm	
1F	
1R	
2F	
2R	
3F	
3R	
4F	
4R	

Commented [TB81]: 94.Is this a target?

Commented [TB82]: 95.Is this a target?

Head flatness: _____

Initials: _____

Sequence IX Draft, April 2018, TWB
(Based on document "Seq IX LSPI Test Method_20180412.docx")

A9.3 Crankshaft Measurements—see Table A9.3.

Commented [TB83]: 96.This table is not mentioned in the method (draft20170505.) – see 8.4.3. If it retained, text is required.in 8.4.3, Otherwise the table should be deleted.

TABLE A9.3 Crankshaft Measurements Record

Engine Number: _____ Date: _____

Test Number: _____ LF _____

Commented [TB84]: 97.What is "LF"?

Instrument Cntrl # (Journal) _____ Instrument Cntrl # (Bearing) _____

Bore Gauge set to 51.986 mm

Main Bearing Journals (mm)				
Diameter: 51.978 mm to 52.002 mm				
Journal Number	Horizontal Diameter	Vertical Diameter	Bearing Inside Diameter	Clearance (0.027mm to 0.052mm)
1				
2				
3				
4				
5				

Commented [TB85]: 98.Is this a target?

Instrument Cntrl # (Journal) _____ Instrument Cntrl # (Bearing) _____

Bore Gauge set to 51.986mm

Sequence IX Draft, [April 2018_TWB](#)
(Based on document "Seq IX LSPI Test Method_20180412.docx")

Rod Bearing Journals (mm)				
<i>Diameter: 51.978 mm to 52.002 mm</i>				
Journal Number	Horizontal Diameter	Vertical Diameter	Bearing Inside Diameter	Clearance (0.027mm to 0.052mm)
1				
2				
3				
4				

Commented [TB86]: 99.Is this a target?

Commented [TB87]: 100.Is this a target?

Instrument Cntrl # (Endplay) _____

Crankshaft End Play (0.22 mm to 0.45 mm) _____

Commented [TB88]: 101.Is this a target?

Sequence IX Draft, [April 2018_TWB](#)
 (Based on document “Seq IX LSPI Test Method_20180412.docx”)

A10_PCM CANBUS PARAMETER ADDRESSES

A10.1 CAN Bus Data—Set up the data acquisition software to record the parameter addresses, as shown in Table A10.1, from the engine’s PCM.

Table A10.24 PCM CANBUS Parameter Identification (PID)

Mode	PID Number (Hex)	Parameter Description	Type	Bytes	Scale	Offset	Minimum	Maximum	Units
1	0E	Ignition Timing Advance for #1 Cylinder	Unsigned Numeric	1	0.5	-64	-64	63.5	°
1	11	Absolute Throttle Position	Unsigned Numeric	1	0.39215686274 5	0	0	100	%
1	05	Engine-Coolant Temperature	Unsigned Numeric	1	1	-40	-40	215	° C
1	0F	Intake-Air Temperature	Unsigned Numeric	1	1	-40	-40	215	° C
1	34	Equivalence Ratio (λ)	Unsigned Numeric	2	0.00003051804 4	0	0	2	unitless
1	43	Absolute Load Value	Unsigned Numeric	2	0.39215686274 5	0	0	25700	%
1	0B	Intake-Manifold Pressure	Unsigned Numeric	1	1	0	0	255	kPa (absolute)
1	23	Fuel-Rail Pressure	Unsigned Numeric	2	10	0	0	655350	kPa (gauge)
1	49	Accelerator-Pedal Position	Unsigned Numeric	1	0.39215686274 5	0	0	100	%
22	033E	Boost Pressure - Raw Value	Unsigned Numeric	2	0.00762939453 1	0	0	499.99237 0605469	kPa (absolute)
22	0462	Turbocharger Wastegate Duty Cycle	Unsigned Numeric	2	0.00305175781 3	0	0	199.99694 8274955	%
22	0318	Actual Intake (A) Camshaft Position	Signed Numeric	2	0.0625	0	-2048	2047.9375	°
22	0319	Actual Exhaust (B) Camshaft Position	Signed Numeric	2	0.0625	0	-2048	2047.9375	Deg
22	0316	Intake (A) Camshaft Position Actuator Duty Cycle	Unsigned Numeric	2	0.00305175781 3	0	0	199.99694 8242188	%
22	0317	Exhaust (B) Camshaft Position Actuator Duty Cycle	Unsigned Numeric	2	0.00305175781 3	0	0	199.99694 8242188	%

Commented [TB89]: 102.Is gauge correct?

Sequence IX Draft, [April 2018_TWB](#)
 (Based on document “Seq IX LSPI Test Method_20180412.docx”)

22	0461	Charge Air-Cooler Temperature	Signed Numeric	2	0.015625	0	-512	511.98437 5	° C
22	05AC	Cylinder 1 Pre-Ignition Counter	Unsigned Numeric	1	1	0	0	255	Count
22	05AD	Cylinder 2 Pre-Ignition Counter	Unsigned Numeric	1	1	0	0	255	Count
22	05AE	Cylinder 3 Pre-Ignition Counter	Unsigned Numeric	1	1	0	0	255	Count
22	05AF	Cylinder 4 Pre-Ignition Counter	Unsigned Numeric	1	1	0	0	255	Count

A11. SETTINGS FOR THE AVL INDICOM COMBUSTION ANALYSIS SYSTEM

A11.1 *General*—The AVL IndiCom is a combustion analysis software package that combines data acquisition and evaluation for graphical presentation. The settings applicable to the Sequence IX test are provided below.

A11.1.1 *Amplifier and Pressure Sensor Settings (accessed through the "Sensor" menu):*

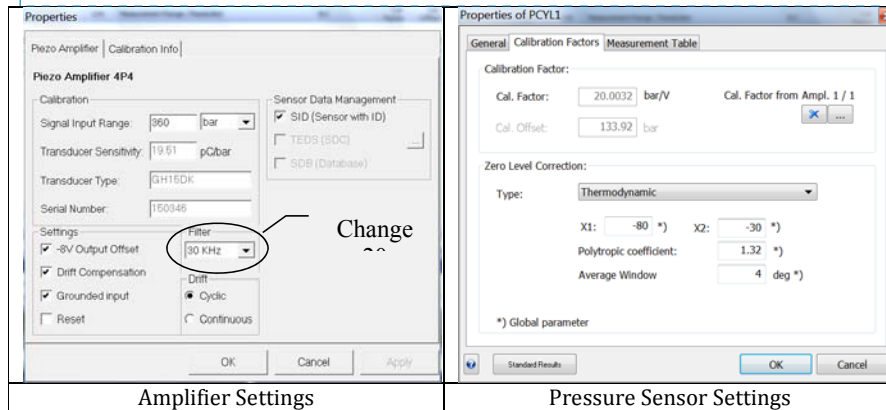

Commented [TB90]: 103.I have added this para by way of explanation. Is it correct?
104. see also my comment to 6.

Commented [TB91]: 105.Make change to amplifier settings as indicated.

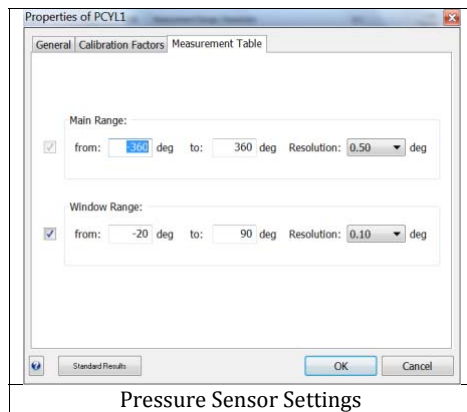

A11.1.2 *Standard Results Settings:*

Sequence IX Draft, [April 2018_TWB](#)
 (Based on document "Seq IX LSPI Test Method_20180412.docx")

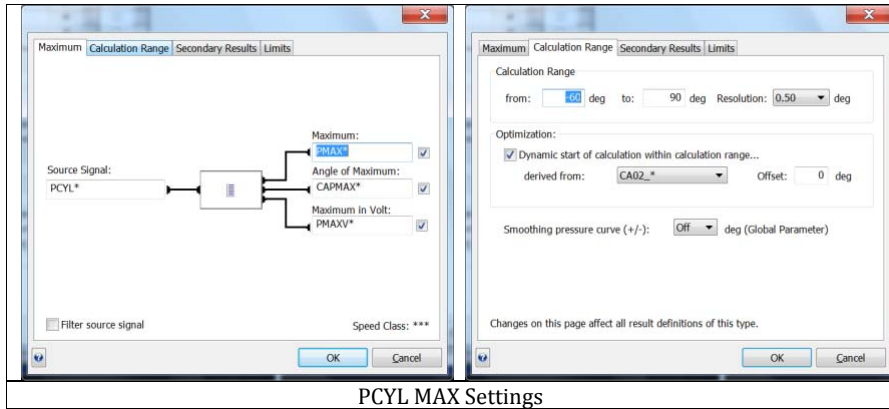

PCYL MAX Settings

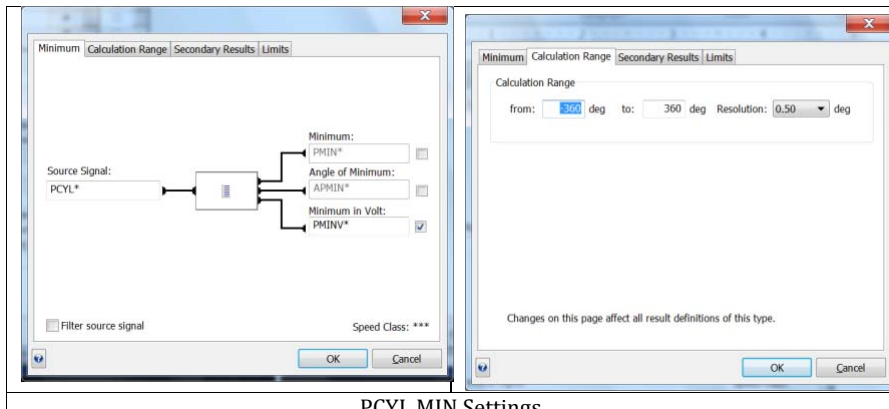

PCYL MIN Settings

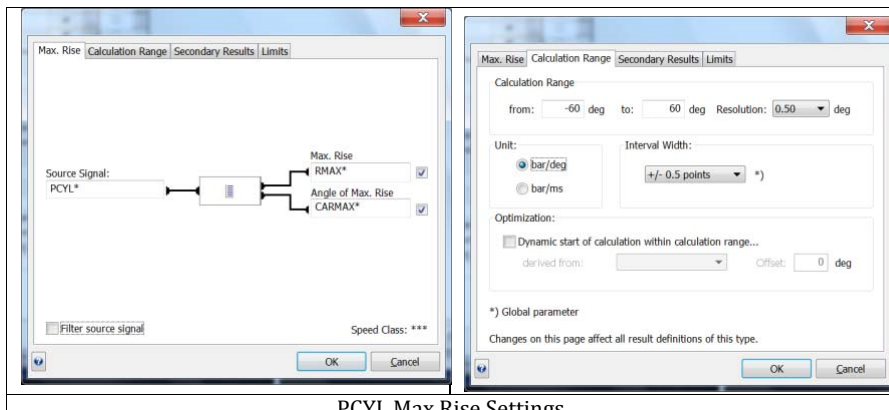

PCYL Max Rise Settings

Sequence IX Draft, [April 2018_TWB](#)
 (Based on document "Seq IX LSPI Test Method_20180412.docx")

PCYL IMEP Settings

PCYL Heat Release Settings

PCYL Heat Release Settings

Sequence IX Draft, [April 2018 TWB](#)
 (Based on document "Seq IX LSPI Test Method_20180412.docx")

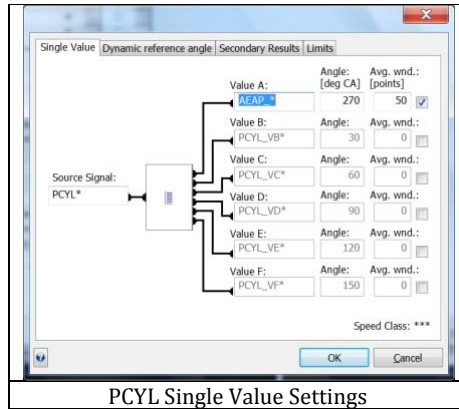

PCYL Single Value Settings

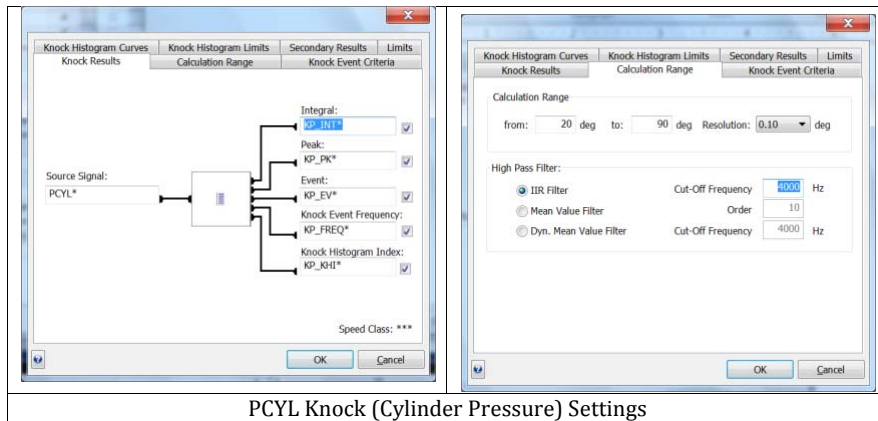

PCYL Knock (Cylinder Pressure) Settings

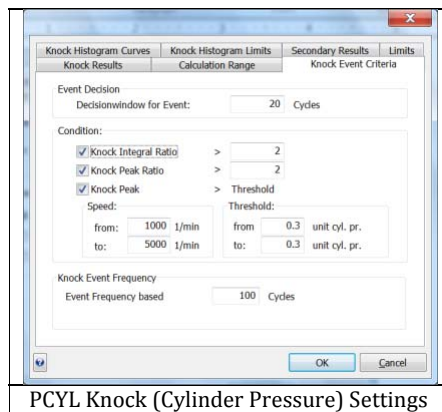

PCYL Knock (Cylinder Pressure) Settings

Sequence IX Draft, [April 2018_TWB](#)
 (Based on document "Seq IX LSPI Test Method_20180412.docx")

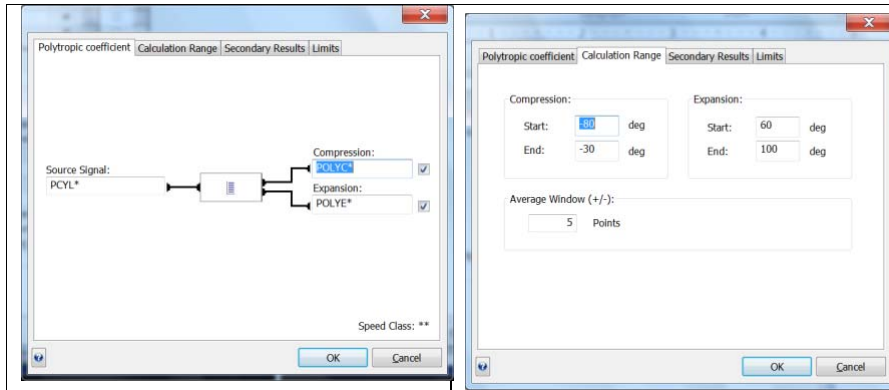

PCYL Polythropic Coefficient Settings

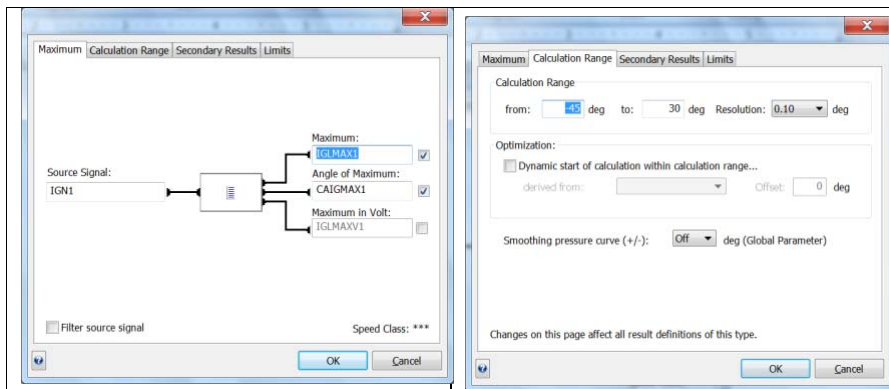

IGN1 MAX Settings

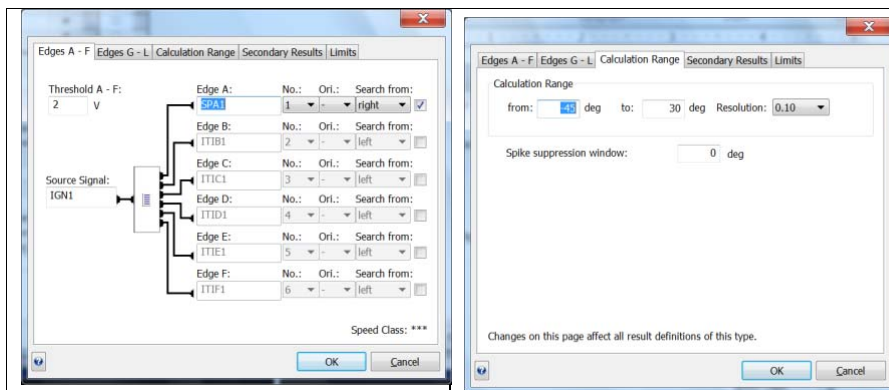

IGN1 Edge Detection Settings

Sequence IX Draft, [April 2018_TWB](#)
(Based on document “Seq IX LSPI Test Method_20180412.docx”)

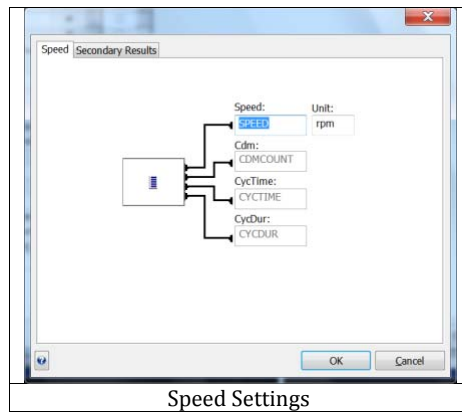
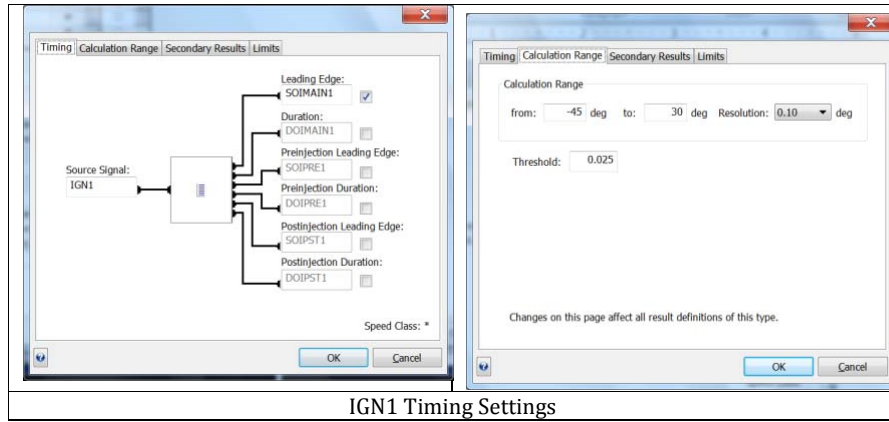

A11.2 Channels To Record—Record the following channels:

- a) PMAX*
- b) MFB2*
- e) PMAXV*
- Ⓢc) PMINV*
- e) KP_INT*

Commented [TB92]: 106. Why do we have * here as they do not appear anywhere else?

A12. SEQUENCE IX REPORT FORMS AND DATA DICTIONARY

A12.1 Download the standardized report form set and data dictionary from the ASTM Test Monitoring Center¹⁹⁴⁹ or obtain them in hardcopy format from the TMC. The contents of the report form set are as follows:

Formatted: Footnote Reference, Font color: Auto

1. Title / Validity Declaration Page	Form 1 <input type="checkbox"/>
2. Table of Contents	Form 2 <input type="checkbox"/>
3. Test Results Summary	Form 3 <input type="checkbox"/>
4. Summary of LSPI Iterations	Form 4 <input type="checkbox"/>
5. Operational Summary – Iteration A <input type="checkbox"/>	Form 5
6. Operational Summary – Iteration B <input type="checkbox"/>	Form 6
7. Operational Summary – Iteration C <input type="checkbox"/>	Form 7
8. Operational Summary – Iteration D <input type="checkbox"/>	Form 8
9. Operational Summary – CAN BUS, Iterations A and B	Form 9 <input type="checkbox"/>
10. Operational Summary – CAN BUS, Iterations C and D <input type="checkbox"/>	Form 10
11. LSPI Cycle Count and Type Summary <input type="checkbox"/>	Form 11
12. LSPI Events Summary-Iteration A <input type="checkbox"/>	Form 12
13. LSPI Events Summary-Iteration B <input type="checkbox"/>	Form 13
14. LSPI Events Summary-Iteration C <input type="checkbox"/>	Form 14
15. LSPI Events Summary-Iteration D <input type="checkbox"/>	Form 15
16. Chemical Analysis <input type="checkbox"/>	Form 16
17. Hardware Information	Form 17 <input type="checkbox"/>
18. Downtime Record	Form 18 <input type="checkbox"/>
19. Comment Record	Form 19 <input type="checkbox"/>
20. ACC Conformance	Form 20

A13. PROCUREMENT OF TEST PARTS AND MATERIALS

A13.1 General

The following provides sources for test parts and materials:

A13.2 *Test Engine Parts*—The required engine parts for use in the SEQUENCE IX test procedure are from the 2.0L GTDI engine and are supplied by the test sponsor (Ford Motor Company):

Ford Motor Co.
Ford Component Sales
290 Town Center Dr
Dearborn, MI 48126.

A13.3 *Various Materials:*

A13.3.1 Obtain the parts listed in A13.3.1.1 from:

OH Technologies
9300 Progress Pkwy.
Mentor, OH 44060.

A13.3.1.1

- a) Coolant inlet and outlet
- b) Flywheel
- c) Clutch
- d) Pressureplate
- e) Spacer
- f) Bellhousing
- g) Dynamometer and engine wire harnesses.

A13.3.2 Obtain the parts listed in A13.3. 2.1 from:

Test Engineering, Inc.
12758 Cimarron Path, Ste. 102
San Antonio, TX 78249-3417.

A13.3.2.1

- a) Modified cylinder head
- b) Piston ring tension measurement.

Sequence IX Draft, [April 2018_TWB](#)
(Based on document "Seq IX LSPI Test Method_20180412.docx")

A13.4 Obtain Type 5 or Type 52 intercooler from FrozenBoost Inc.,
www.frozenboost.com.

A13.5 Obtain the powertrain control module (PCM) from Ford Motor Company,
attn.: Ron Romano, 313-845-4068, rromano@ford.com.

Commented [TB93]: 107.Suggest we give a general title for the contact in Ford because when Ron moves on we will have to revise the method.

APPENDIX

(Nonmandatory Information)

X1. SOURCES OF INFORMATION AND MATERIALS

X1.1 General

X1.1.1 The following sources are provided for convenience only. This does not represent an exclusive or complete listing of required materials or information sources.

X1.2 Engine Measurement Record Forms

X1.2.1 The necessary engine measurement record forms are shown in [Figs. A2.24 – A2.26](#).

Commented [TB94]: 108. There are no Figs A2.24 to A2.26.
Do we mean Tables A9.1 to A9.3?

X1.3 Sources Of Information

X1.3.1 *ASTM Test Monitoring Center*—Direct all communications to the TMC to:

ASTM Test Monitoring Center

6555 Penn Ave.

Pittsburgh, PA 15206-4489.

X1.3.2 *Test Sponsor*—Direct all communications with the test sponsor (Ford Motor Co.) to:

Ford Motor Company

Diagnostic Service Center II

1800 Fairlane Drive,

Room 410

Allen Park, MI 48101.

X1.3.4 *Fuel Information and Availability*—Obtain general information concerning EEE fuel, including availability, from:

Haltermann Products

1201 S. Sheldon Rd.

P.O. Box 249

Channelview, TX 79530-0429.

Halterman Carliss

Commented [TB95]: 109.Why is this entry here?

X1.4 Sources of Materials

X1.4.1 *Aeroquip Hose and Fittings*—Obtain from:

Aeroquip Corp.
1225 W. Main
Van Wert, OH 45891.

X1.4.2 *Flowmeter coolant*

Commented [TB96]: 110.What is manufacturer and P/N?

X1.4.3 *Intake-Air Humidity Instruments*—Dewpoint meters from the following sources are suitable for measurement of the intake-air specific humidity:

- a) Alnor (the Dewpointer)
- b) EG & G
- c) Foxboro
- d) Hy-Cal
- e) General Eastern
- f) Protimeter.

X1.4.4 *Heat Exchangers*—Obtain ITT Standard Heat Exchangers from:

Kinetics Engineering Corp.
2055 Silber Road, Suite 101
Houston, TX 77055.

X1.4.5 *Fuel Flow Measurement*—Mass fuel flowmeters are available from:

Micro Motion Corp.
7070 Winchester Circle
Boulder, CO 80301.

X1.4.6 *Parts Washer and Chemicals*—A dishwasher type parts cleaner and associated chemicals can be obtained from:

Better Engineering Manufacturing
8361 Town Court Center

Sequence IX Draft, [April 2018_TWB](#)
(Based on document “Seq IX LSPI Test Method_20180412.docx”)

Baltimore, MD 21236-4964.

X1.4.7 Crankcase and Intake-Air Pressure Gauges—Obtain from:

Dwyer Instrument Co.

Junction of Indiana State Highway 212 and U.S. Highway 12

P.O. Box 373

Michigan City, IN 46360.

X1.4.8 *Lubricants*—Obtain EF-411 from local distributors of ExxonMobil products.

Commented [TB97]: 111.EF-411 is not mentioned in the method. Where is it used?

X1.4.9 *Tygon Hose*—Tygon hose is available through local Cadillac Plastic Co. distributors or the following supplier:

The Norton Co.

12 East Avenue

Tallmadge, OH 44278.

X1.4.10 *Special Tools for the Test Engine*—Special tools to facilitate assembly and disassembly of the engine are available from:

Commented [TB98]: 112. I have given this reference in 7.5.2 footnote 14. Is that correct or are they also available from Ford?

Owatonna Tool Co.

2013 4th St.

NW Owatonna, MN 55060.

X1.4.11 *Ultrasonic Parts Cleaner*: Obtain TierraTech model MOT500NS ultrasonic parts cleaner or similar from:

TierraTech,

Draper Business Park,

12227 South Business Park Drive,

Suite 100,

Draper, UT 84020.

sales@tierratech.com.

X1.4.12 *Ultrasonic Cleaner*—Obtain TierraTech Ultrasonic solution 7 and B cleaner from TierraTech (see X1.4.11).

Sequence IX Draft, [April 2018_TWB](#)
(Based on document "Seq IX LSPI Test Method_20180412.docx")

X1.4.13 *Organic Solvent*—Obtain Penmul L460 from:

Penetone Corp.,
P.O. Box 22006,
Los Angeles, CA 90022.

X1.4.14 *Parts Cleaning Soap*—Obtain NAT-50 and PDN-50 from:

Better Engineering Manufacturing,
8361 Town Court,
Baltimore, MD 21236.

X1.4.15: *Hatchview Software*—Obtain from:

<http://digitalmetrology.myshopify.com/products/hatchview>

Commented [TB99]: 113. There is no mention of this software in the method. Where is it used?

X1.4.16 *USB microscope*—

Commented [TB100]: 114. There is no mention of a microscope in the method. Where is it used? And what is the source?

X1.4.17 *Ford camshaft alignment tool*—Obtain Ford P/N 303-1565 from a Ford or Lincoln dealer.

X1.4.18 *Crankshaft TDC timing peg*—Obtain Ford P/N 303-507 from a Ford or Lincoln dealer.

X1.4.19 *Dynamometer*—Obtain Midwest dynamometer model MW-1014A from:
OHT

or from:

Dyne Systems, Inc.,
W209 N17391 Industrial Drive,
Jackson, WI 53037 USA, tel:800-657-0726

or from

Dyno One Inc.,
14671 N 250 W Edinburgh,
IN 46124.

info@dyno-one.com; Tel 812-526-0500

X1.4.20 *Rear Motor Mount*—Obtain Quicksilver P/N 6628-A from:

Sequence IX Draft, [April 2018_TWB](#)
(Based on document “Seq IX LSPI Test Method_20180412.docx”)

Quicksilver ???

Commented [TB101]: 115.What is the address of Quicksilver – it is not given in X2.1.33 of draft 20170505 and I can't find it via Google 116.

X1.4.21 *Carburetor Cleaner*—Obtain Chemtool B12 from:

Berryman Products, Inc,
3800 E. Randol Mill Rd,
Arlington, TX 76011.
Tel: +1 800 433 1704; www.berrymanproducts.com.