

IVB Draft	Sequence IVB Engine Assembly Manual New Engine Preparation	Section 1
October 19, 2017		Sheet 1

New Engine Disassembly Procedure

The new Toyota 2NR-FE engine is delivered as a long block assembly. If the engine is equipped with a flywheel assembly, remove the flywheel. Install the engine on a suitable engine stand in the engine build area.

Refer to Figure 1:

1. Drain engine oil by removing the oil drain plug with a 14 mm socket wrench.
2. Remove oil filter (A).
3. Disconnect the positive crankcase valve (PCV) hose (B) from the valve cover and intake manifold connections, and remove.
4. Using a 10 mm socket wrench, remove three (3) bolts on the stock throttle body (C), and remove.
5. Using an adjustable wrench, remove the oil pressure sensor (D).
6. Using a 10 mm socket wrench, remove the bolt to remove the crankshaft position sensor (E).

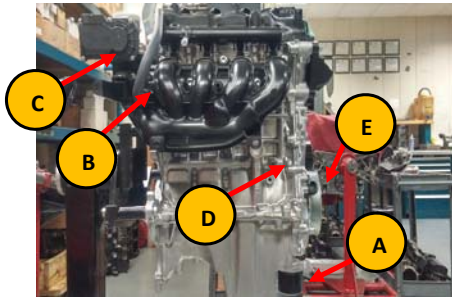

Figure 1

Refer to Figure 2:

7. Using a 10 mm socket wrench, remove the bolt at the coolant inlet pipe bracket (A), and remove and remove the coolant inlet pipe and O-ring.
8. Using a 10 mm socket wrench, remove two (2) bolts on the coolant outlet assembly (B), and remove the coolant outlet assembly and gasket.
9. Using an adjustable wrench, remove the coolant temperature sensor unit (C).
10. Using a 10 mm socket wrench, remove the four (4) bolts on the ignition coil packs, and remove the ignition coil packs.
11. Using a 16 mm spark plug socket wrench, remove the four (4) spark plugs.

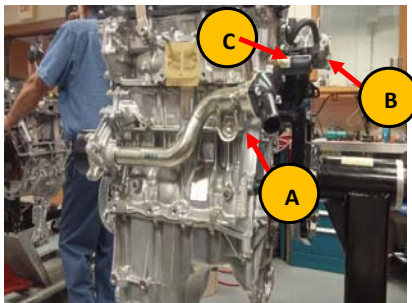

Figure 2

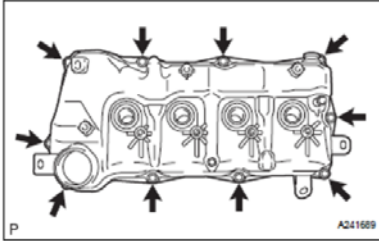

Figure 3

Refer to Figure 3:

12. Using a 10 mm socket wrench, remove the ten (10) bolts from the valve cover.
13. Remove the valve cover and the valve cover gasket. If the gasket is stuck to the cylinder head, carefully use a plastic scraper to cut through the RTV sealant at the front cover to release the gasket.

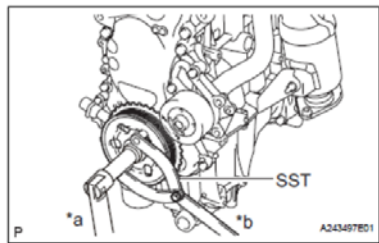

Figure 4

Refer to Figure 4:

14. Insert the prongs of the crankshaft pulley installation tool (OHT p/n OHTIVB-10010-1) into the holes of the crankshaft pulley. Hold onto the handle to prevent the crankshaft from rotating.
15. Using a 19 mm socket wrench, remove the crankshaft pulley bolt, and remove the crankshaft pulley.



Figure 5

Refer to Figure 5:

16. Using a 14 mm socket wrench, remove the three (3) bolts on the engine mounting bracket.

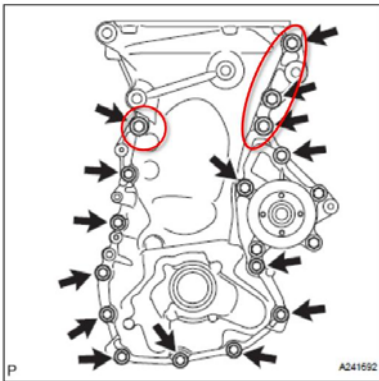

Figure 6

Refer to Figure 6:

17. Using the appropriate socket wrench, remove the thirteen (13) bolts on the engine front cover. The four (4) circled bolts must be removed with a 14 mm socket wrench. The remaining nine (9) bolts must be removed with a 10 mm socket wrench.

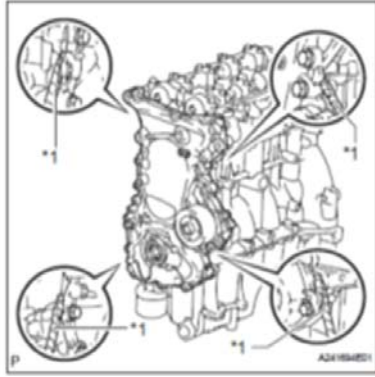

Figure 7

Refer to Figure 7:

18. Using a flat-head screwdriver, remove the front cover by prying at the four indicated positions shown.

NOTE: Tape the tip of the screwdriver to prevent damaging the contact surfaces between the engine front cover, engine block, oil pan, and cylinder head.

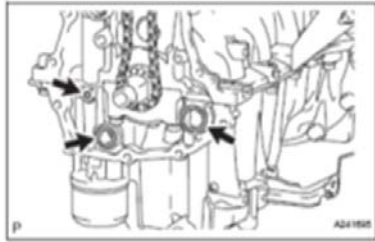

Figure 8

Refer to Figure 8:

19. Remove the front cover gasket and two O-rings, as indicated.



Figure 9

20. Rotate the engine crankshaft clockwise until the cylinder #1 piston is at top-dead-center (TDC) of the compression stroke, which can be confirmed with the following visual cues. The directions noted in the following description are valid when viewing the engine from the front.

- Cylinder 1 intake cam lobes are pointed towards the left (see Figure 9).
- Cylinder 1 exhaust cam lobes are pointed towards the right (see Figure 9).
- Rectangular marks on the camshaft sprockets are positioned vertically (see Figure 9).
- TDC mark on the crankshaft pulley (*1) is aligned with the TDC mark inscribed on the front cover (see Figure 10)

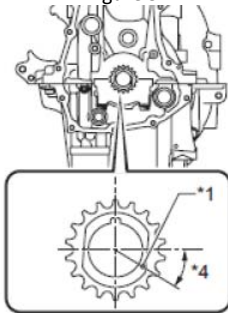

Figure 10

IVB Draft	Sequence IVB Engine Assembly Manual New Engine Preparation	Section 1
October 19, 2017		Sheet 4



Figure 11

Refer to Figure 11:

21. Using a plastic scraper, clean all residual RTV sealant from the surfaces of the engine oil pan, engine block, and cylinder that were contact the engine front cover.
22. Remove the Toyota oil pan from the engine block.

This concludes the new engine disassembly procedure. Please ship the unmodified Toyota front cover and unmodified Toyota oil pan while retaining the oil pump gears to the central parts distributor, OHT, for modification into a test part.

IVB Draft	Sequence IVB Engine Assembly Manual New Engine Preparation	Section 1
October 19, 2017		Sheet 5

OHT Oil Pan (OHT p/n OHTIVB-022-1) Assembly Procedure

Refer to Figure 11:

1. Install OHT the two cord seal (OHT p/n IVB022-21) pieces into the grooves along the top of the oil pan.
2. Install OHT O-ring seal (OHT p/n IVB022-20) into the O-ring groove (A). Use a suitable adhesive, such as petroleum jelly to hold the O-ring in place.
3. Install the drain plug gasket (OHT p/n OHTIVB-12031-1) onto the new central drain plug.
4. Install the pan onto the engine block torquing the bolts to 20 N·m (14.8 lbf-ft) in a zig-zag pattern working from the outside to the center of the pan.

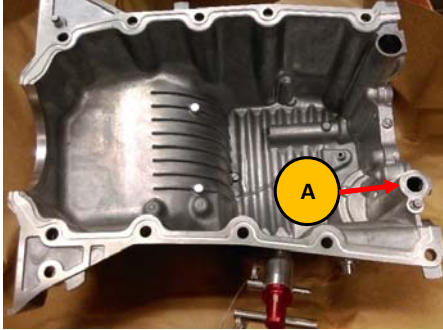

Figure 12

OHT Front Cover (OHT p/n OHTIVB-003-1) Assembly Procedure



Figure 13

Refer to Figure 12:

1. Install the oil pump gears into the OHT front cover with the triangular marks matched with the markings on the housing.
2. Apply a light coat of EF-411 assembly fluid on the gears and mating surfaces.



Figure 14

Refer to Figure 14:

3. Install the oil pump cover. Tighten indicated screws to 10 N·m (7.4 lbf-ft) using a Phillips-head driver adapted to a torque wrench.

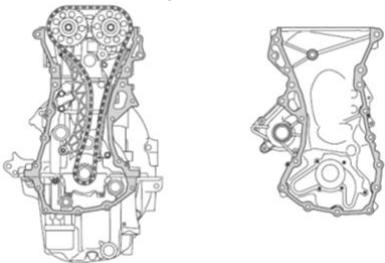

Figure 15

Refer to Figure 15:

4. Clean and degrease the front cover mating surfaces, shaded in gray. A suitable scraper, may be used to remove residual RTV sealant from the mating surface. Inspect the timing cover for damage from the timing chain prior to installation.

Comment [k1]: Add timing cover inspection

IVB Draft	Sequence IVB Engine Assembly Manual New Engine Preparation	Section 1
October 19, 2017		Sheet 7

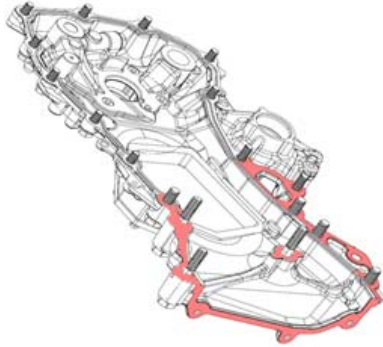

Figure 16

Refer to Figure 16:

5. Install OHT cord O-ring seal (OHT p/n IVB003-2) into the O-ring groove. Use petroleum jelly to hold the O-ring in place.

6. Apply RTV sealant, AC Delco 12378521 RTV is recommended, to the highlighted areas.

Note: Keep RTV sealant on the outside of the O-ring to prevent contamination with engine oil.

New Engine Reassembly Procedure

Figure 17

Refer to Figure 17:

1. Apply a light coat of EF-411 assembly fluid to the three (3) new O-rings (OHTIVB-19023-1, OHTIVB-27014-1, and OHTIVB-09031-1).
2. Install the O-rings to positions A, B, and C.

Note: Be careful not to drop any oil on the contact surfaces for the front cover, cylinder head, engine block, and oil pan.

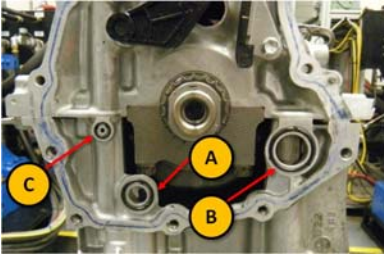
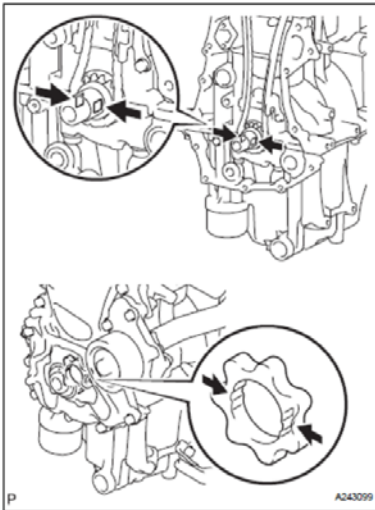

Figure 18

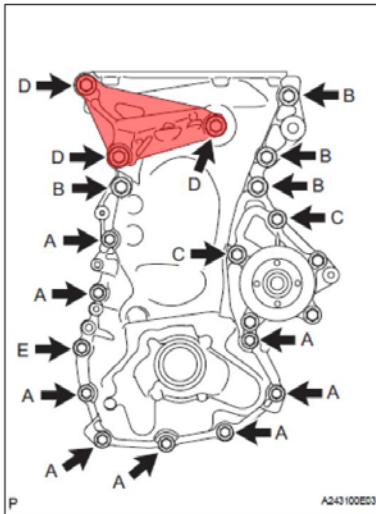

Figure 19

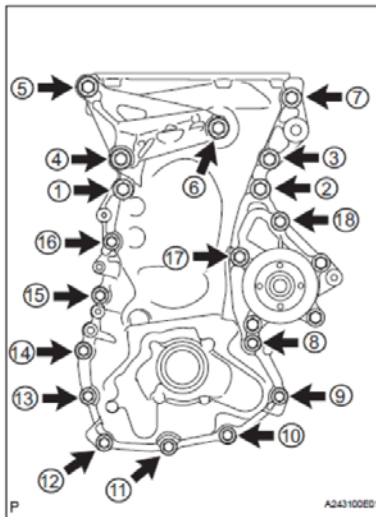

Figure 20

Refer to Figure 19:

3. Install the OHT front cover onto the engine. Ensure that the oil pump rotor spline properly fits onto the crankshaft.
4. Install the front engine mounting bracket (highlighted).
5. Install the eighteen (18) bolts as indicated. The length of each bolt is designated in Table 1, below. Hand-tighten only.

Note: Stock front cover is displayed in Figure 19 for illustration purposes only. OHT modified front cover should be used.

Table 1: Bolt dimensions and target torques in Figure 19

Item	Length	Thread Diameter	Target Torque
Bolts A, E	25 mm (0.984 in)	8 mm (0.315 in)	24 N-m (18 lbf-ft)
Bolt B	40 mm (1.57 in)	10 mm (0.394 in)	51 N-m (38 lbf-ft)
Bolt C	40 mm (1.57 in)	8 mm (0.315 in)	24 N-m (18 lbf-ft)
Bolt D	70 mm (2.76 in)	10 mm (0.394)	51 N-m (38 lbf-ft)

6. Apply a thread adhesive to Bolt E before installing.

Refer to Figure 20:

7. Tighten the eighteen (18) bolts to the target torque in the sequence shown.

Note: Stock front cover is displayed in Figure 20 for illustration purposes only. OHT modified front cover should be used.

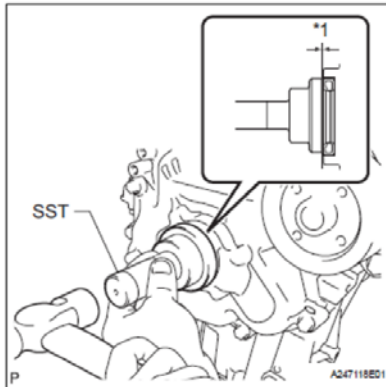

Figure 21

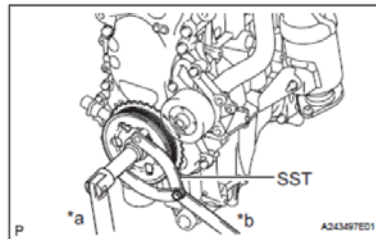

Figure 22

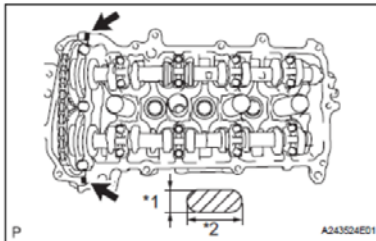

Figure 23

Refer to Figure 21:

8. Apply EF-411 to the lip of a new crankshaft oil seal (OHT p/n OHTIVB-90311-1). Make sure that the lip is clean of foreign matter.
9. Position the crankshaft oil seal on its recess on the front cover. Place the seal insert tool (OHT p/n IVB002-11) on top of the crankshaft oil seal.
10. Using a hammer, tap the SST to push the crankshaft oil seal into its recess. The top surface of the crankshaft oil seal should not be above the top surface of the recess by more than 0.5 mm (0.0197 in), and it should not be below it by more than 1.0 mm (0.0394 in).

Note: Ensure that the SST is perpendicular to the crankshaft oil seal as it is tapped to prevent crankshaft oil seal from cocking within the recess.

Refer to Figure 22:

11. Align the pulley set key on the crankshaft with the key groove of the crankshaft pulley. Slide the crankshaft pulley onto the crankshaft.
12. Insert the prongs of the crankshaft pulley installation tool (OHT p/n OHTIVB-10010-1) into the holes of the crankshaft pulley. Hold onto the handle to prevent the crankshaft from rotating.
13. Using a 19 mm socket wrench, torque the crankshaft pulley bolt to 164 Nm (121 lbf-ft).

Refer to Figure 23:

14. Apply a small amount of RTV sealant, AC Delco 12378521 RTV is recommended, to the indicated areas at the mating interface between the OHT front cover and the cylinder head.

Note: The applied sealant should take up no larger than an area of 2.0 x 5.0mm (0.079 x 0.197in).

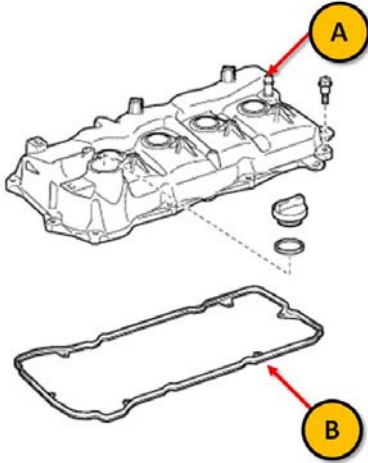

Figure 24

Refer to Figure 24:

15. Install a new cylinder head cover gasket (OHT p/n OHTIVB-11213-1) (B) on the stock valve cover (A).

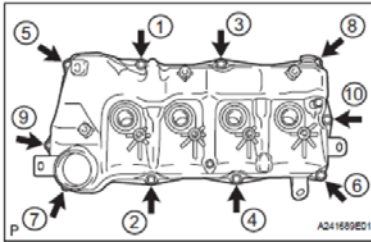

Figure 25

Refer to Figure 25:

16. Install the valve cover onto the cylinder head. Install the ten (10) bolts. Hand-tighten only.
17. Using a 10mm socket drive torque wrench, torque the bolts in the sequence shown to 10 Nm (7 lbf-ft).

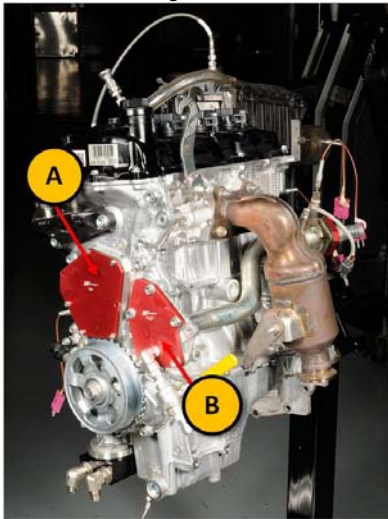

Figure 26

Refer to Figure 26:

18. Install the front cover tensioner access plate (A) (OHT p/n IVB003-3) and gasket (OHT p/n IVB003-4). Install seven (7) nuts on studs or seven bolts. Hand-tighten only.
19. Using an 8 mm socket torque wrench, torque the bolts or nuts to 11 Nm (8 lbf-ft).
20. Install the water pump block off plate (B) (OHT p/n OHTIVB-004-1) and gasket (OHT p/n IVB004-1). Install the five (5) nuts or bolts. Hand-tighten only.
21. Using a 13 mm socket torque wrench, torque the nuts to 24 Nm (18 lbf-ft).

IVB Draft	Sequence IVB Engine Assembly Manual New Engine Preparation	Section 1
October 19, 2017		Sheet 12

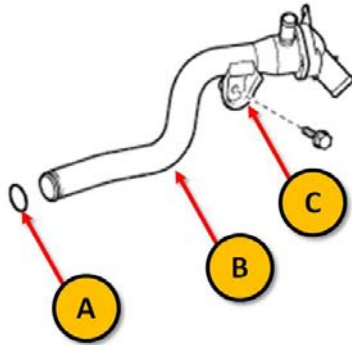

Figure 27

Refer to Figure 27:

22. Install OHT modified coolant inlet pipe (B) (OHT p/n OHTIVB-16268-1) with gasket (A) (OHT p/n IVB007-1) at the coolant pump housing inlet.
23. Install the bolt at the OHT modified coolant inlet pump bracket (C). Hand-tighten only.
24. Using a 12 mm socket torque wrench, torque the bolt to 24 Nm (18 lbf-ft).

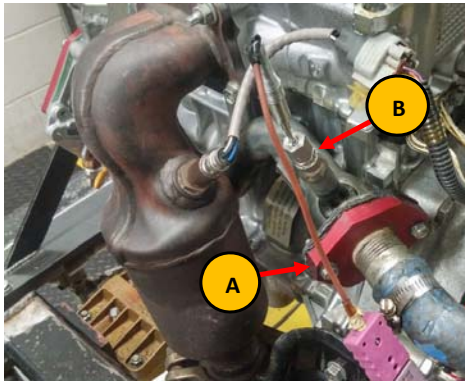

Figure 28

Refer to Figure 28:

25. Install the OHT coolant inlet adaptor plate (A) (OHT p/n OHTIVB-007-1) and gasket (OHT p/n IVB007-1) at the end of the OHT modified coolant inlet pipe with two (2) bolts. Using a 10 mm socket torque wrench, torque the bolts to 14 Nm (10 lbf-ft).
26. Install a 1/8 in x 4 in E-type thermocouple (TEI p/n X27622-652-00) into the compression fitting at the indication position (B) on the OHT modified coolant inlet pipe. Position the thermocouple such that the distance from the end to the compression fitting is approximately 12 mm (0.472 in). Using an adjustable wrench, tighten the compression fitting until snug.

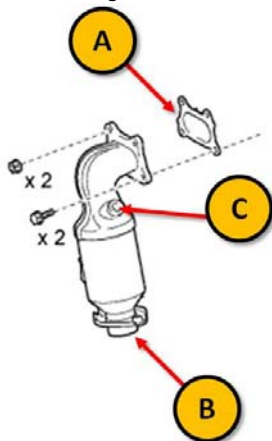

Figure 29

Refer to Figure 29:

27. Install a new exhaust manifold gasket (A) (OHT p/n OHTIVB-17173-1) and exhaust pipe assembly (B) (OHT p/n OHTIVB-17400-1) with two bolts and two nuts. Hand-tighten only.
28. Install the heated oxygen sensor (OHT p/n OHTIVB-89465-1) at position (C). Using a 7/8 in crow's foot adapted to a torque wrench with a 30cm (11.8in) long handle, tighten heated oxygen sensor to 40 Nm (30 lbf-ft).

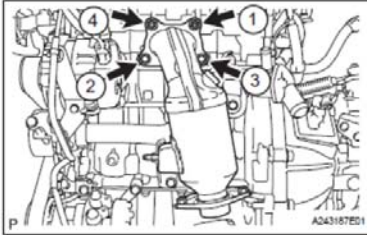

Figure 30

Refer to Figure 30:

29. Using a 12 mm socket torque wrench, torque the bolts and nuts to 27 Nm (20 lbf-ft) in the sequence shown.

Note: OEM pipe shown.

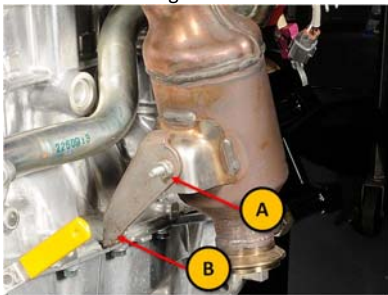

Figure 31

Refer to Figure 31:

30. Install the exhaust manifold stay (OHT p/n OHTIVB-17568-1) with the nut (A) and the bolt (B). Using a 12 mm socket torque wrench, torque the nut and bolt to 27 Nm (20 lbf-ft).

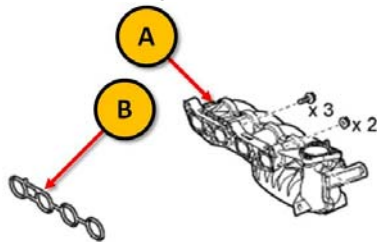

Figure 32

Refer to Figure 32:

31. Install a new intake manifold gasket (B) (OHT p/n OHTIVB-17177-1) onto the intake manifold (A).

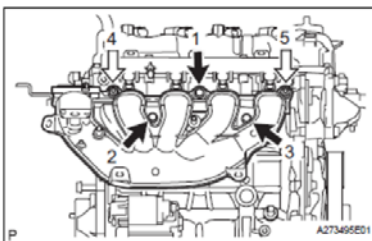

Figure 33

Refer to Figure 33:

32. Install the intake manifold and gasket onto the cylinder head using the three (3) bolts, indicated with black arrows, and two (2) nuts, indicated with white arrows. Hand-tighten only.

33. Using a 12 mm socket torque wrench, torque the bolts and nuts to 21 Nm (15 lbf-ft) in the sequence shown.

Note: The throttle body and intake air box should still be attached to the intake manifold.

IVB Draft	Sequence IVB Engine Assembly Manual New Engine Preparation	Section 1
October 19, 2017		Sheet 14

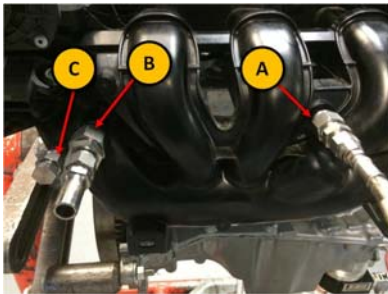

Figure 34

Refer to Figure 34:

34. Install the intake manifold pressure transducer line adapter (A) (Swagelok p/n SS-600-4AN), blowby ventilation hose adapter (B) (Swagelok p/n SS-600-R-8 and Swagelok p/n SS-810-R-6), and intake manifold pressure sensor plug (C) (Swagelok p/n 4BLEN4-316) on their respective ports on the intake manifold.

35. Tighten the compression fittings on each component with an adjustable wrench until snug.

Refer to Figure 35:

36. Connect the intake air box ventilation port with the valve cover ventilation port with the fresh air ventilation hose (A) (3/8" Tygon hose and 5/8" Tygon hose). Secure with 16 mm (0.625 in) hose clamps.

37. Connect the positive crankcase ventilation (PCV) port with the blowby ventilation hose adapter with the blowby ventilation hose (B). Secure with spring clamps (OHT p/n OHTIVB-90460-1).

38. Install the intake air pressure transducer line adapter (C) on the intake air box. Using an adjustable wrench, tighten the nut until snug.

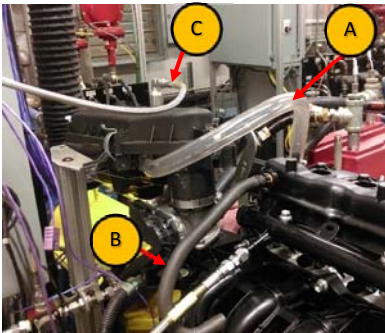

Figure 35

Refer to Figure 36:

39. Install a 1/8 in x 4" E-type thermocouple (TEI p/n X27622-652-00) into the compression fitting at the indication position (A) on the intake air box. Position the thermocouple such that the distance from the end to the compression fitting is approximately 34 mm (1.339 in). Using an adjustable wrench, tighten the compression fitting until snug.

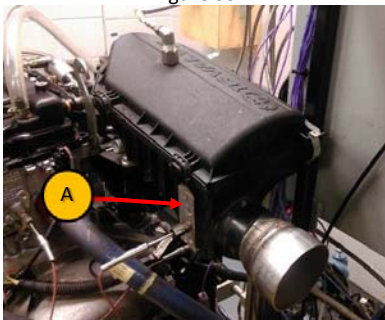

Figure 36

Comment [k2]: Hard copy mentions this should be revised but I am not sure what should change?

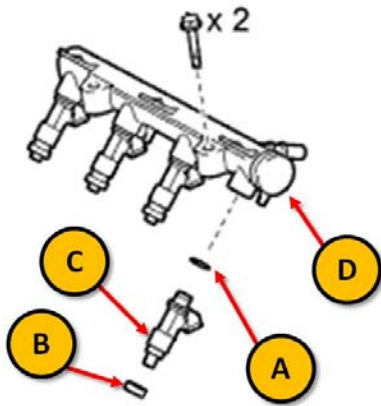

Figure 37

Refer to Figure 37:

40. Install the injector vibration insulator (B) (OHT p/n OHTIVB-23291-1) and injector O-ring (A) (OHT p/n OHTIVB-07033-1) on each of the four (4) fuel injectors (C).
41. Install the fuel injectors onto the fuel rail (D).

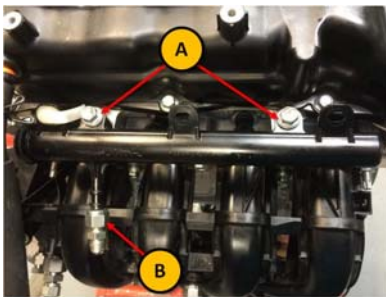

Figure 38

Refer to Figure 38:

42. Install the fuel rail onto the cylinder head with two (2) bolts (A). Hand-tighten only.
43. Using a 12 mm socket torque wrench, torque the bolts to 24 Nm (18 lbf-ft).
44. Install the fuel supply line adapter (B) (Swagelok p/n SS-600-6-6AN) on the fuel supply port on the fuel rail. Using an adjustable wrench, tighten the compression fitting until snug.

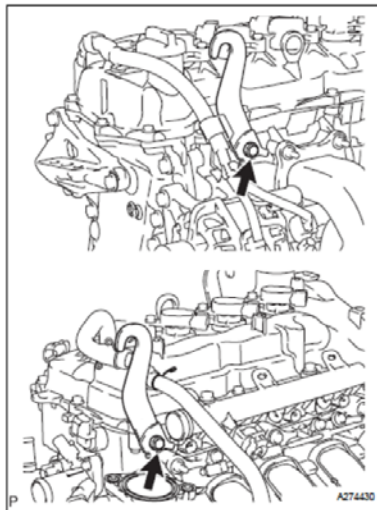

Figure 39

Refer to Figure 39:

45. Install the engine hangers with two (2) bolts at the indicated positions. Hand-tighten only.
46. Using a 12 mm socket torque wrench, torque the bolts to 32 Nm (24 lbf-ft).

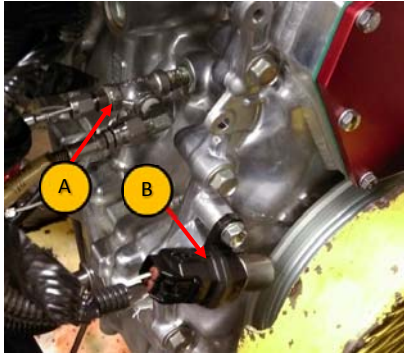

Figure 40

Refer to Figure 40:

47. Install the oil gallery tee (A) (Grainger p/n ILYK3 and Connect p/n 1/8-4AN SS) in the indicated position. Wrap the threads of the male adapter of the tee with Teflon tape. Using an adjustable wrench, tighten the tee against the engine block until snug.
48. Install a 1/8 in x 4 in E-type thermocouple (TEI p/n X27622-652-00) into the compression fitting. Make sure the tip of the thermocouple is in the middle of the flow stream, which is approximately 6 mm (0.236 in) from its end to the compression fitting. Using an adjustable wrench, tighten the compression fitting until snug.
49. Install the crankshaft position sensor (B) with a bolt. Using a 10mm socket torque wrench, torque to the bolts to 7.5 Nm (5.5 lbf-ft).

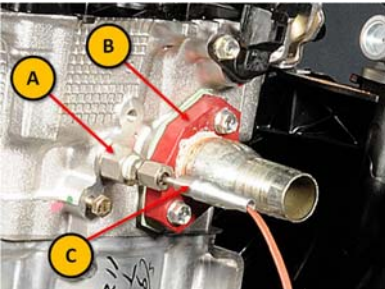

Figure 41

Refer to Figure 41:

50. Install OHT coolant outlet adapter plate (B) (OHT p/n OHTIVB-005-1) and gasket (OHT p/n IVB005-1) with two (2) bolts. Using a 10mm socket torque wrench, torque the bolts to 14 Nm (10 lbf-ft).
51. Install coolant outlet thermocouple adapter plate (A) (12 mm to 1/8"NPT w/ O-ring and a compression fitting for a thermocouple) at the indicated position. Apply Teflon tape at the male end of the adapter. Using an adjustable wrench, tighten the adapter against the cylinder head until snug.
52. Install a 1/8 in x 3 in E-type thermocouple (TEI p/n X27621-652-00) into the compression fitting. Make sure the tip of the thermocouple is in the middle of the flow stream, which is approximately 6 mm (0.236 in) from its end to the compression fitting. Using an adjustable wrench, tighten the compression fitting until snug.

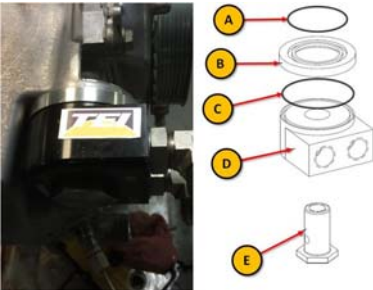

Figure 42

Refer to Figure 42:

53. Assemble the oil filter adapter as shown. The components are listed in Table 2, below.

Table 2: Oil filter adapter components

ID	TEI p/n	Description
A	Monroe p/n 4.00 x 62 x 4 B70	4 mm x 62 mm OD O-ring
B	SEQIVB-02-10-01	Oil filter adapter ring
C	Monroe p/n 4.00 x 72 x 4 B70	4 mm x 72 mm OD O-ring
D	MOROSO 23682	Remote oil filter adapter
E	SEQIVB-02-10-02	Oil filter adapter sleeve nut

IVB Draft	Sequence IVB Engine Assembly Manual New Engine Preparation	Section 1
October 19, 2017		Sheet 17

54. Using a 1-1/2 in socket torque wrench, torque the oil filter adapter sleeve nut to 54 Nm (40 lbf-ft).

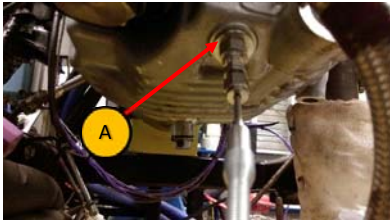

Figure 43

Refer to Figure 43:

55. Install a 1/8 in by 3 in E-type thermocouple into fitting A

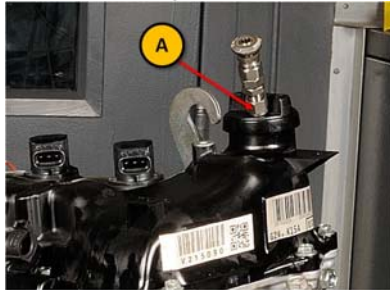

Figure 44

Refer to Figure 44:

56. Install the modified oil fill cap (A) (Parker p/n 4AH4CYSSP 1/4" x 1/4").

57. Insert the prongs of the crankshaft pulley installation tool (OHT p/n OHTIVB-10010-1) into the holes of the crankshaft pulley. Hold onto the handle to prevent the crankshaft from rotating. Refer back to Figure 4.

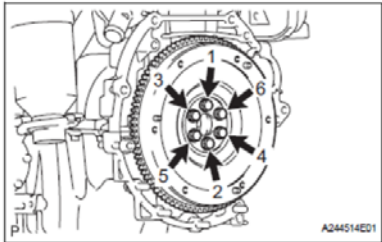

Figure 45

Refer to Figure 45:

58. Apply sealant to two or three threads at the end of each flywheel bolt. Use Loctite Blue 242, or equivalent.

59. Install the flywheel with six (6) flywheel bolts. Using a 14 mm socket torque wrench, torque each bolt to 78 Nm (58 lbf-ft) in the sequence shown.

This concludes the new engine reassembly procedure.

Clutch Assembly Procedure

This procedure details the steps required to install the clutch assembly on an engine. This procedure is to be conducted on all new test engines, engines that have undergone cylinder head swap (see Toyota Engine Assembly Manual, Section 3), or if the previously-installed clutch assembly is found to be damaged and require replacement. The engine should be lifted on a hoist and hung from the two engine hangers.



Figure 46

- Refer to Figure 46:
1. Install pilot shaft bearing (A) (OHT p/n IVB001-11) into the pilot hole in the rear of the crankshaft. Use a universal bearing installation kit to ensure that the bearing is set in the recess without cocking.
Note: The pilot shaft bearing is only needed to be installed once in a new engine. It does not need to be removed.

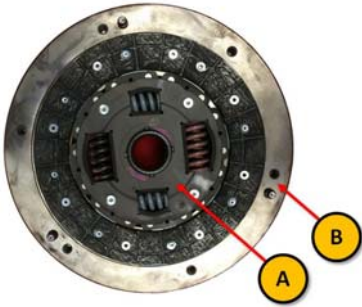

Figure 47

- Refer to Figure 47:
2. Place clutch disc assembly (A) (OHT p/n OHTIVB-31250-1) onto the flywheel (B).

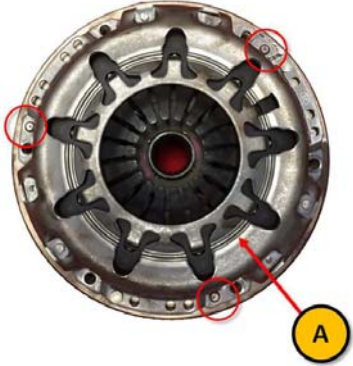

Figure 48

- Refer to Figure 48:
3. Install the clutch cover assembly (A) (OHT p/n OHTIVB-31210-1) onto the flywheel. Align the flywheel dowel pins with the holes on the clutch cover, as indicated.
 4. Secure the clutch cover assembly to the flywheel with six (6) bolts around the perimeter of the flywheel. Hand-tighten only such that the pressure plate can still be moved within the clutch cover assembly.

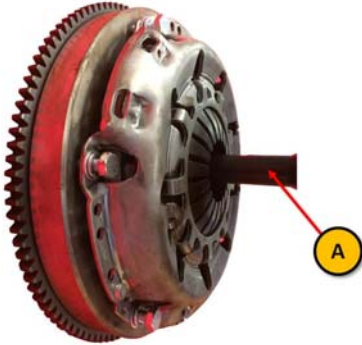

Figure 49

Refer to Figure 49:

5. Insert the pilot output shaft (A) (OHT p/n IVB001-3) to center pressure plate spline with the flywheel pilot shaft bearing.
6. Using a 13 mm socket torque wrench, torque the bolts to 24 Nm (18 lbf-ft) in a criss-cross pattern.
Note: Do not use an impact wrench to tighten the bolts.
7. Remove the pilot shaft after the bolts have been tightened.

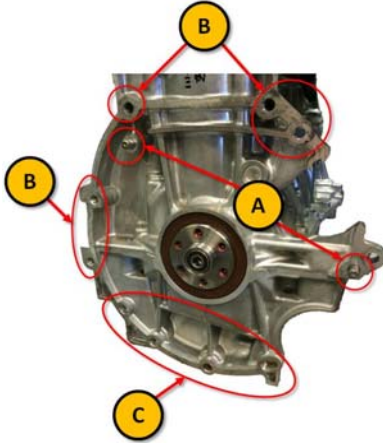

Figure 50

Refer to Figures 50 and 51:

8. Install the OHT modified bell housing (OHT p/n OHTIVB-001-1) on the rear of the engine. Align the bell housing with the two dowel pins on the engine (A).
- Note: The flywheel with clutch assembly is not shown in Figure 50.**
9. Secure the bell housing with nine (9) bolts. Five (5) bolts must be installed using a 17 mm socket torque wrench at position (B). Four bolts must be installed using a 14 mm socket torque wrench at position (C). Torque all bolts to 81 Nm (60 lbf-ft).
Note: Do not use an impact wrench to tighten the bolts.

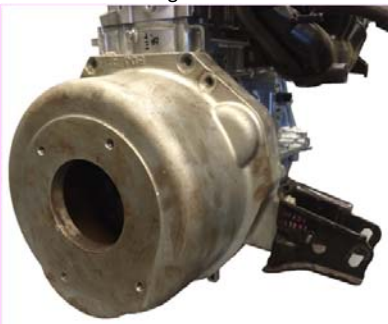

Figure 51

Comment [k3]: Picture Update?

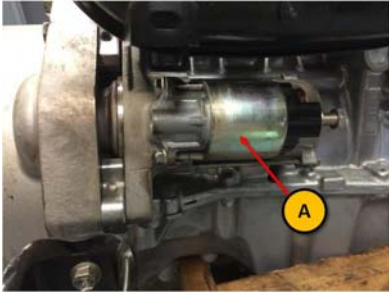

Figure 52

Refer to Figure 52:

10. Install starter assembly (A) (OHT p/n OHTIVB-28100-1) with the top bolt only. Ensure that the starter gear meshes with the flywheel gear teeth before tightening bolts.

Note: Do not install the bolt at the bottom of the starter assembly.

11. Using a 14mm socket torque wrench, torque the bolts to 54 Nm (40 lbf-ft).

Note: Do not use an impact wrench to tighten the bolts.

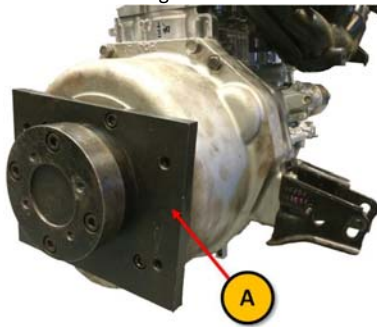

Figure 53

Refer to Figure 53:

12. Install pilot output shaft (OHT p/n IVB001-3) onto the OHT modified bell housing. Ensure that the pilot shaft spline align with the clutch pressure plate spline.

13. Secure pilot output shaft with four (4) screws. Using a 3/8" Allen drive torque wrench, torque the bolts to 81 Nm (60 lbf-ft).

Note: Do not use an impact wrench to tighten the bolts.

This concludes the clutch assembly procedure. The engine is currently read to be installed on the test stand. Please refer to the engine installation procedure. In order to remove the clutch, perform the clutch assembly procedure in reverse. An impact wrench may be used to loosen bolts during the clutch removal procedure.

Engine Installation Procedure

This procedure details the steps required to install the assembled test engine on the test stand. This procedure is to be conducted if a used engine has been removed for maintenance or if a new engine is to be installed. At this stage, the clutch assembly and the OHT modified bell housing should also be installed on the engine. The engine should be lifted on a hoist and hung from the two engine hangers.

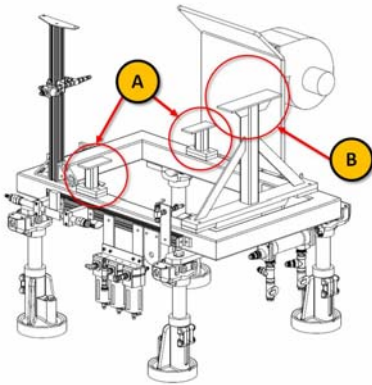

Figure 54

Refer to Figure 54:

1. Using an engine hoist, allow the engine to hang over the engine frame. Align the engine such that the bell housing mounts are over indicated area (A), and the front engine mount is over indicated area (B).

Note: The front engine mount bracket is not secured to the engine frame to allow for engine installation from the front of the test stand.

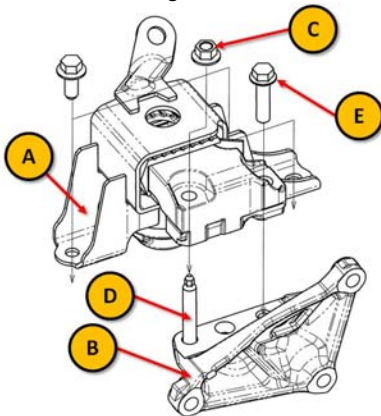

Figure 55

Refer to Figure 55:

2. Install the front engine mount insulator (A) (OHT p/n OHTIVB-12305-1) on the front engine mount (B) on the engine. Secure with flanged bolt (E) (OHT p/n OHTIVB-10469-1). Note the stud (D) is no longer part of the sub-assembly.
3. Using a 14 mm socket torque wrench, torque the nut and bolt to 52 Nm (38 lbf-ft).

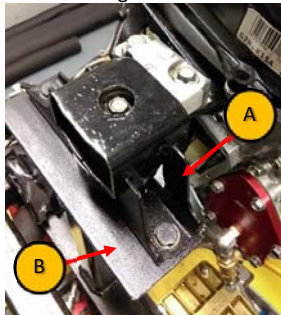

Figure 56

Refer to Figure 56:

4. Secure the front engine mount insulator (A) to the front engine mount bracket (B) with two (2) bolts (Grainger p/n 1UE71) and two (2) nuts (Grainger p/n 3HDX7). Using a 16 mm box end wrench, hold the nut on the underside of the front engine mount bracket. Using a 16 mm socket torque wrench, torque the bolts to 52 Nm (38 lbf-ft).

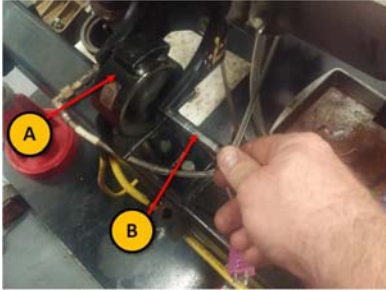

Figure 57



Figure 58



Figure 59

Refer to Figure 57:

5. Install intake-side bell housing mount insulator (OHT p/n OHTIVB-12361-1) on the intake-side bell housing mount. Secure with flanged bolt (OHT p/n OHTIVB-81020-1) and flanged nut (OHT p/n OHTIVB-10016-1). Hand-tighten only. Arrows on the mounts should point towards the engine.
6. Install the exhaust-side bell housing mount insulator (A) (OHT p/n OHTIVB-12371-1) on the exhaust-side bell housing mount. Secure with flanged bolt (B) (OHT p/n OHTIVB-81025-1). Hand-tighten only. Arrows on the mounts should point towards the engine.

Refer to Figure 58:

7. Adjust the vertical position of the intake-side bell housing mount until the roll of the engine with respect to the crankshaft axis of rotation is $4.5^\circ \pm 0.5^\circ$ upwards on the intake side.

Refer to Figure 59:

8. Confirm that the pitch of the engine with respect to the crankshaft axis of rotation is $0^\circ \pm 0.5^\circ$
Note: If the orientation of the engine cannot be achieved, check to make sure that the engine frame is level on all four sides, and adjust the elephant's feet height as necessary. If orientation is still not achieved, consider replacing the engine mount insulators.
9. Using a 14 mm socket torque wrench, secure the position of the engine by torquing the flanged bolts and nuts on the bell housing mounts on both intake and exhaust sides to 24 Nm (18 lbf-ft). Hold the flanged nut in place with a 14 mm box end wrench while tightening the bolts.



Figure 60

Refer to Figure 60:

- Attach the exhaust pipe to header pipe converter with a brass gasket (TEI p/n SEQIVB-02-02-05) and exhaust bolted clamp (A) (TEI p/n 329920HPIW). Using a 3/4 in box end wrench, hold the bolt head on the clamp in place. Using a 3/4 in socket torque wrench, torque the nut on the clamp to 54 Nm (40 lbf-ft).

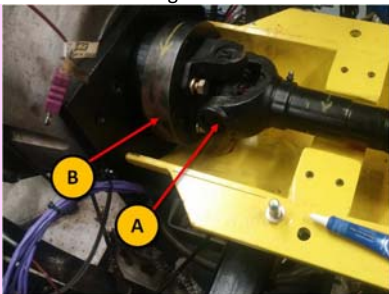

Figure 61

Refer to Figure 61:

- Install the driveshaft (A) on the adapter of the pilot output shaft (B) with four (4) bolts. Apply Loctite Blue 242, or equivalent, to the threads of each bolt. Install each bolt with a lock washer. Using a 5/8 in socket wrench, torque each bolt to 54 Nm (40 lbf-ft).
Note: Do not use an impact wrench to tighten the bolts.

Comment [k4]: Update this picture?

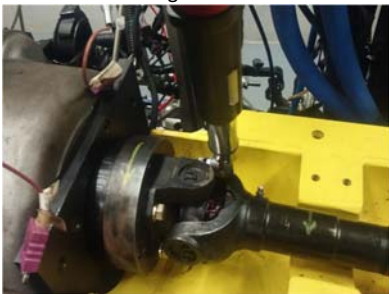

Figure 62

Refer to Figure 62:

- Inject U-joint grease, or equivalent, into the front and rear U-joint of the driveshaft until excess grease starts to overflow from within the joint.

Comment [k5]: Spec?

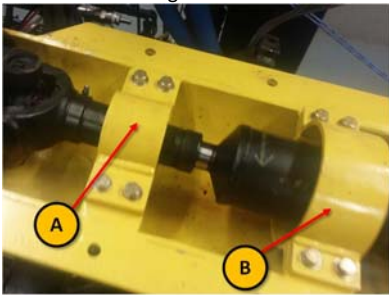

Figure 63

Refer to Figure 63:

- Install the inner guards (TEI p/n SEQIVB-06-03 (A) and SEQIVB-06-04 (B)) at the designated locations with eight (8) bolts. Install a flat washer with each bolt. Using a 1/2 in socket torque wrench, torque each bolt to 27 Nm (20 lbf-ft).



Figure 64

Refer to Figure 64:

14. Install the upper driveshaft guard (TEI p/n SEQIVB-06-02) with six (6) bolts. Install a flat washer with each bolt. Using a 3/4 in socket torque wrench, torque each bolt to 81 Nm (60 lbf-ft).

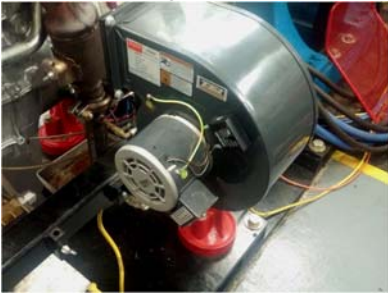

Figure 65

Refer to Figure 65:

15. Install the exhaust cooling fan (TEI p/n 1TDT2) and with two (2) bolts at the engine frame. Using a 9/16 in socket wrench, torque each bolt to 47 Nm (35 lbf-ft).

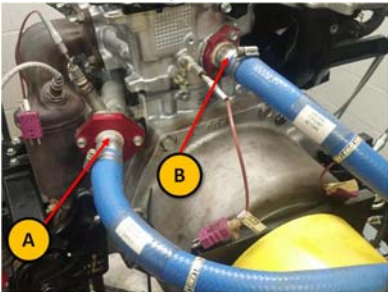

Figure 66

Refer to Figure 66:

16. Install the coolant inlet hose (A) and coolant outlet hose (B) with hose clamps on each hose. Using a flat-head screwdriver, tighten the hose clamps until snug.



Figure 67

Refer to Figure 67:

17. Connect the fuel supply line (A) and manifold pressure transducer line (B) to the designated ports. Using an adjustable wrench, tighten each compression fitting until snug.

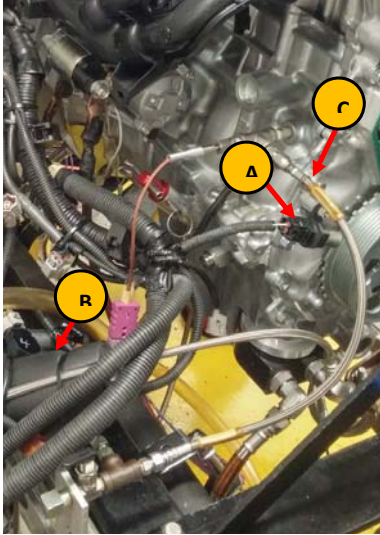

Figure 68

Refer to Figure 68:

18. Connect the knock sensor and crankshaft position sensor (A) with their respective connectors on the engine wiring harness. Place the knock sensor in the insulated tubing attached to sump oil pressure transducer line (B).

19. Connect the oil gallery pressure transducer line (C) to the designated port. Using an adjustable wrench, tighten the compression fitting until snug.

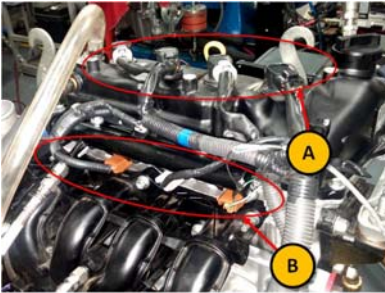

Figure 69

Refer to Figure 69:

20. Install the ignition coil packs (A) in their respective positions.

Note: The positions of each ignition coil pack should have been labeled prior to removal.

21. Connect the fuel injectors (B) with their respective connectors on the engine wiring harness.

Note: The connector colors should alternate between brown and gray from front to rear of the engine.

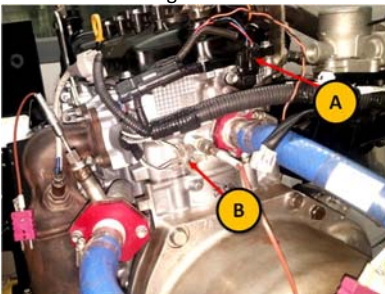

Figure 70

Refer to Figure 70:

22. Connect the camshaft position sensor (A) with its respective connector.

23. Attach the wiring harness engine ground (B) at its designated location with a bolt. Using a 12 mm socket torque wrench, torque the bolt to 14 Nm (10 lbf-ft).



Figure 71

Refer to Figure 71:

24. Attach the wiring harness engine ground (A) at its designated location with a bolt. Using a 12 mm socket torque wrench, torque the bolt to 14 Nm (10 lbf-ft).

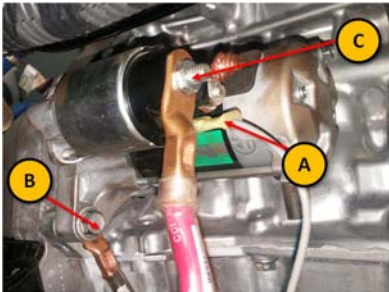

Figure 72

Refer to Figure 72:

25. Connect the starter solenoid switch signal wire (A) to the designated connector on the starter.
26. Connect the battery ground cable (B) to the designated position on the starter with a bolt. Using a 17mm socket torque wrench, torque the bolt to 54 Nm (40 lbf-ft).
27. Connect the battery hot wire (C) to the designated position on the starter with a nut. Using a 12 mm socket torque wrench, torque the nut to 10 Nm (7 lbf-ft).



Figure 73

Refer to Figure 73:

28. Secure the intake air box to the top of the intake air and fuel regulator assembly with bolt at the designated position (A). Using a 5/16 in Allen drive torque wrench, torque the bolt to 20 Nm (15 lbf-ft).

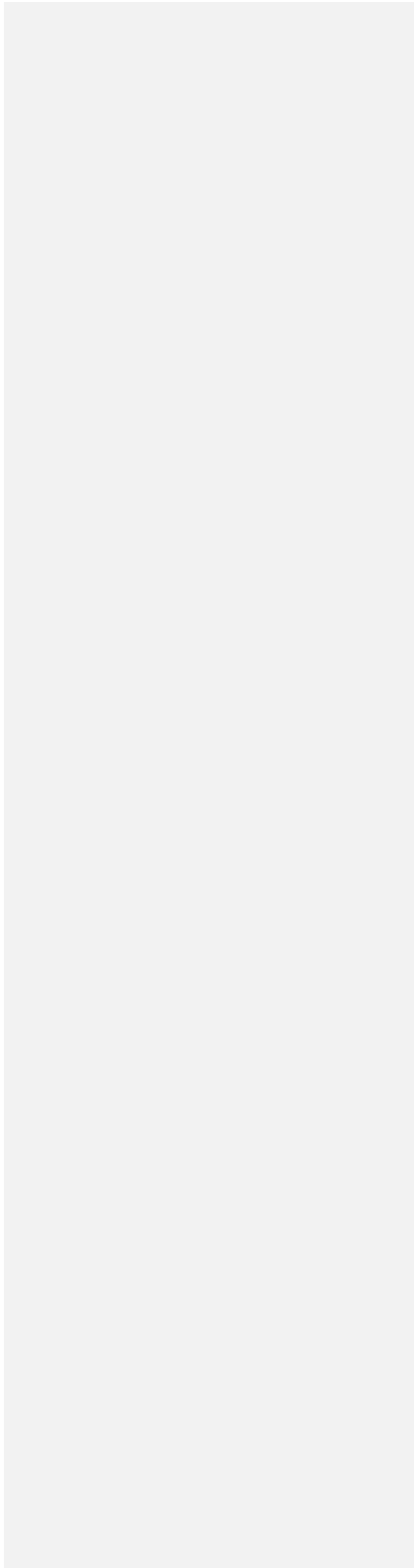

Figure 74

Refer to Figure 74:

29. Securely install the crank pulley guard (TEI p/n IVB001-5) on the front of the stand.

IVB Draft	Sequence IVB Engine Assembly Manual New Engine Preparation	Section 1
October 19, 2017		Sheet 27
<p data-bbox="66 401 1174 489">This concludes the test engine installation procedure. The engine is ready to undergo break-in, which is detailed in the Section D of the Sequence IVB Lab Operations Manual. To remove the engine from the test stand, conduct the steps detailed in this procedure in reverse. An impact wrench may be used to loosen bolts.</p>		



Note:

This section outlines the procedure for installing a new camshaft and lifter set for test in the test cell. Technicians must make sure they follow all safety guidelines and lock out procedures specified by each laboratory before performing these procedures.

Caution:

All dynamometer operating systems must be locked out before performing these operations.

Camshaft and Lifter Removal Procedure

Figure 1

Refer to Figure 1:

1. Ensure that the starting system has been disabled to prevent accidental cranking of engine. Lock out or disconnect starter electrical cable to engine (A).
2. Remove the safety guard (B) from around the front pulley to allow access to the front of the engine.

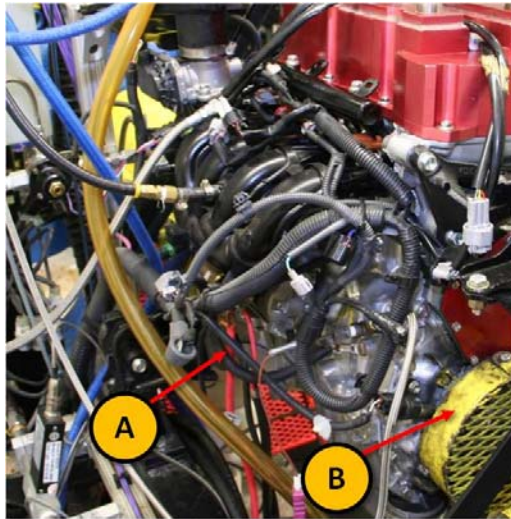
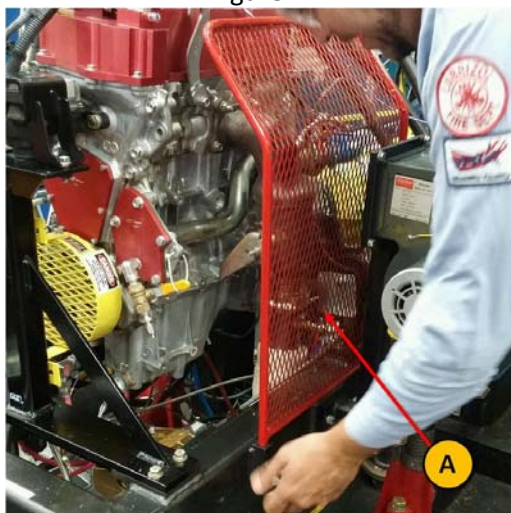

Figure 2

Refer to Figure 2:

3. Remove the exhaust safety guard (A) from the exhaust system to allow access to the left side of the engine.

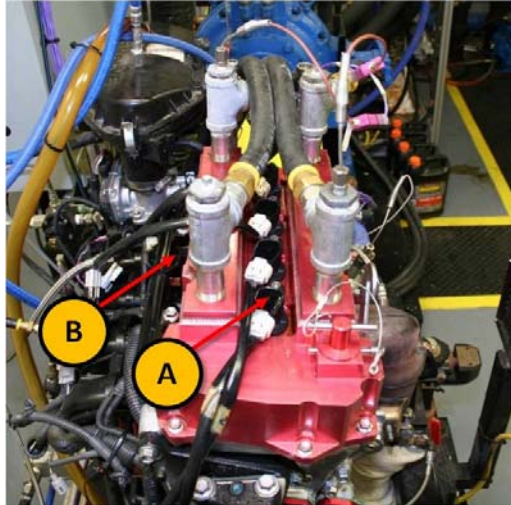

Figure 3

Refer to Figure 3:

4. Using a marker, mark the four (4) ignition coil packs (A) with their respective positions.
5. Using a 5 mm Allen drive socket wrench, remove the bolts securing each of the four (4) coil packs. Keep the coil packs connected to the harness. The spaces between the intake manifold runners (B) are a good location to place the coil packs once removed.

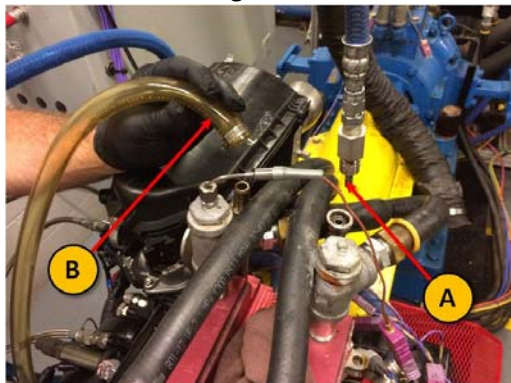

Figure 4

Refer to Figure 4:

6. Remove the crankcase pressure transducer line (A) and the crankcase ventilation line (B).



Figure 5

Refer to Figure 5:

7. Remove the jacketed rocker cover (OHT p/n OHTIVB-002-1) and place the rocker cover assembly on the driveshaft guard. Do not disconnect the coolant hoses from the jacketed rocker cover.

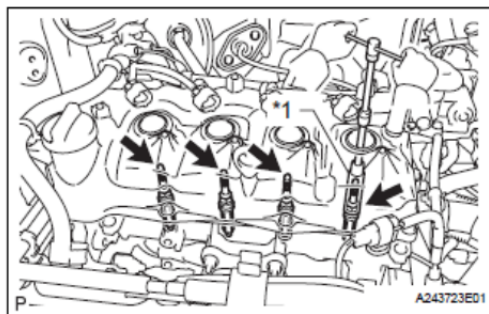

Figure 6

Refer to Figure 6:

8. Using a 16 mm spark plug socket wrench, remove the spark plugs from all cylinders.

Refer to Figure 7:

9. Using a 19 mm socket wrench, rotate the crankshaft clockwise until the cylinder #1 piston is at top-dead-center (TDC) of the compression stroke, which can be confirmed with the following visual cues. The directions noted in the following description are valid when viewing the engine from the front.
 - a. Cylinder 1 intake cam lobes (A) are pointed towards the left (see Figure 8).
 - b. Cylinder 1 exhaust cam lobes (B) are pointed towards the right (see Figure 8).
 - c. Rectangular marks (C) on the camshaft sprockets are positioned vertically (see Figure 10).
 - d. TDC mark (D) on the crankshaft pulley is aligned with the TDC mark inscribed on the front cover (see Figure 9)



Figure 7

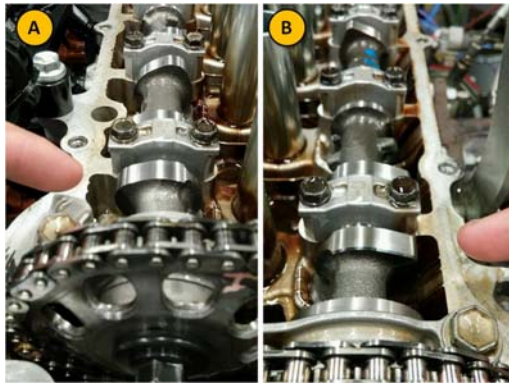

Figure 8

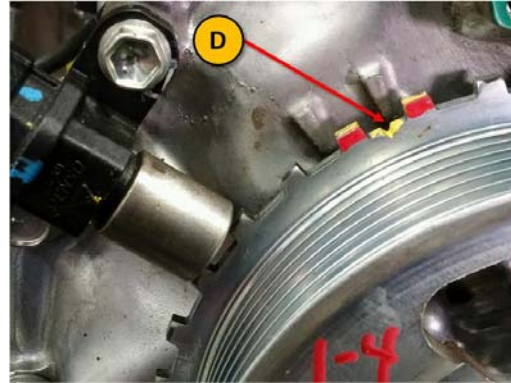

Figure 9

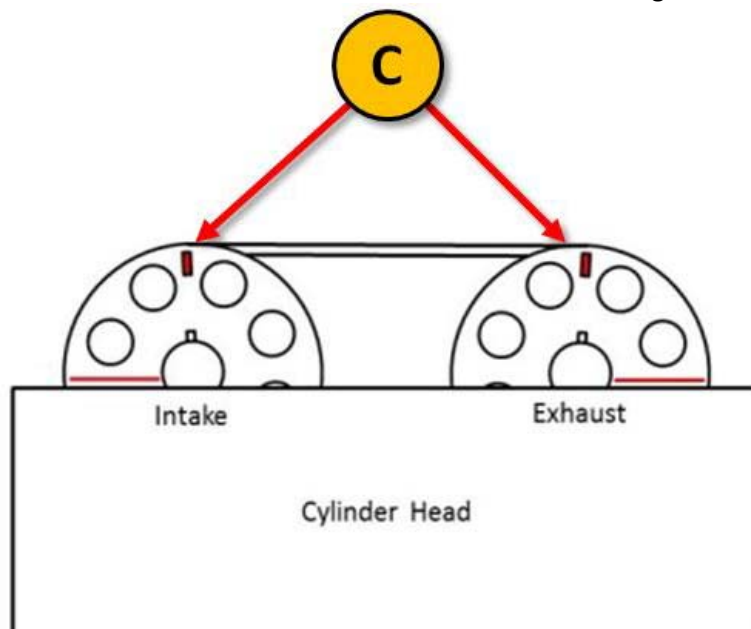

Figure 10



Figure 11

Refer to Figure 11:

10. Using a marker, mark the chain link that is aligned with the rectangular marks on the camshaft sprockets.

Note: Unlike conventional timing alignment procedures, it is not necessary to align the gold links on the timing chain.



Figure 12

Refer to Figure 12:

11. If not already present, scribe permanent reference marks on the camshaft sprockets and crankshaft pulley to ensure proper alignment during reassembly. The marks are scribed on the intake camshaft sprocket (A) and the exhaust camshaft sprocket (B).

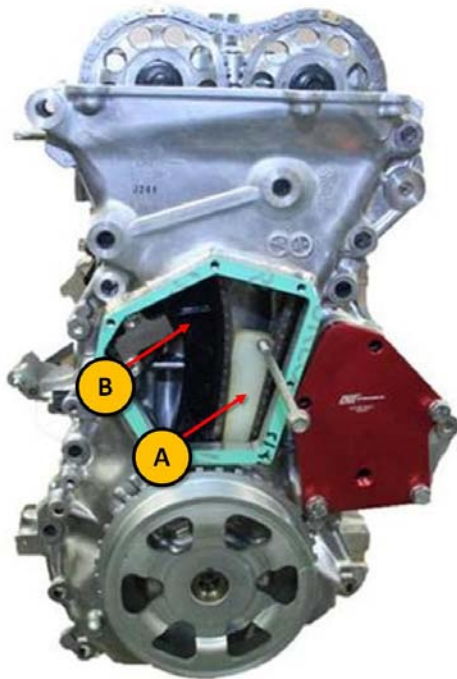

Figure 13

Refer to Figure 13:

12. Remove the timing chain access cover (OHT p/n IVB003-3) and gasket (OHT p/n IVB003-4) from the OHT front cover (OHT p/n OHTIVB-003-1). Insert a wedge (A) between the chain tensioner arm (B) and chain tensioner guide. Push the wedge down, making sure that it is firmly in place, preventing the chain tensioner arm from collapsing onto the guide.

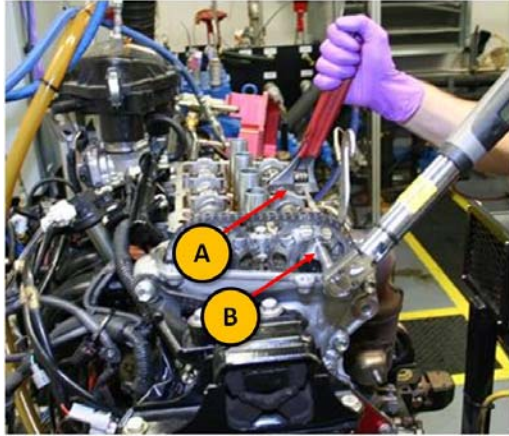

Figure 14

Removing exhaust camshaft sprocket bolts

Refer to Figure 14:

13. Hold the camshaft in position with an adjustable wrench. Tighten the wrench jaws on the 19 or 20 mm wrench flats located in the middle of the camshaft (A).

Note: Do not loosen or tighten camshaft sprocket bolts using only the timing chain to prevent the sprocket from rotating.

14. While holding the camshaft use an open-ended wrench or a crow's foot wrench attachment (B) to loosen the camshaft sprocket bolt. Take care not to damage the front cover sealing surfaces.

Note: Do not remove camshaft sprocket bolts from the intake camshaft.

Removing exhaust camshaft and bearing end caps

Refer to Figure 15:

15. Carefully remove exhaust camshaft bolt and sprocket without dislodging the timing chain wedge. Carefully lay the chain into the timing cover.

16. Loosen front bearing end cap bolts with a 12 mm socket speed handle. Loosen remaining bearing end cap bolts with a 10 mm socket speed handle in the following order: E5, E2, E4, E3.

Note: Only loosen bearing end cap bolts in ¼-turn increments.

17. Remove exhaust camshaft and bearing end caps.



Figure 15

Removing intake camshaft and bearing end caps

18. Loosen bearing end cap bolts with a 10 mm socket speed handle in the following order: I5, I2, I4, I3. Remove the bearing end caps.

Note: Only loosen bearing end cap bolts in ¼-turn increments.

Refer to Figure 16:

19. Carefully remove the timing chain from the intake camshaft sprocket. Carefully lay the chain into the timing cover. Remove the intake camshaft.



Figure 16



Figure 19

Refer to Figure 19:

23. Clean the OHT jacketed rocker cover of oil residue by spraying with degreasing solvent. Wipe oil residue off with lint-free terry towels. Air-dry with clean, dry compressed air.



Figure 20

Refer to Figure 20:

24. Remove oil in the cylinder head valve deck using a vacuum cart or syringe (A). Suction as much oil from the valve deck as possible.

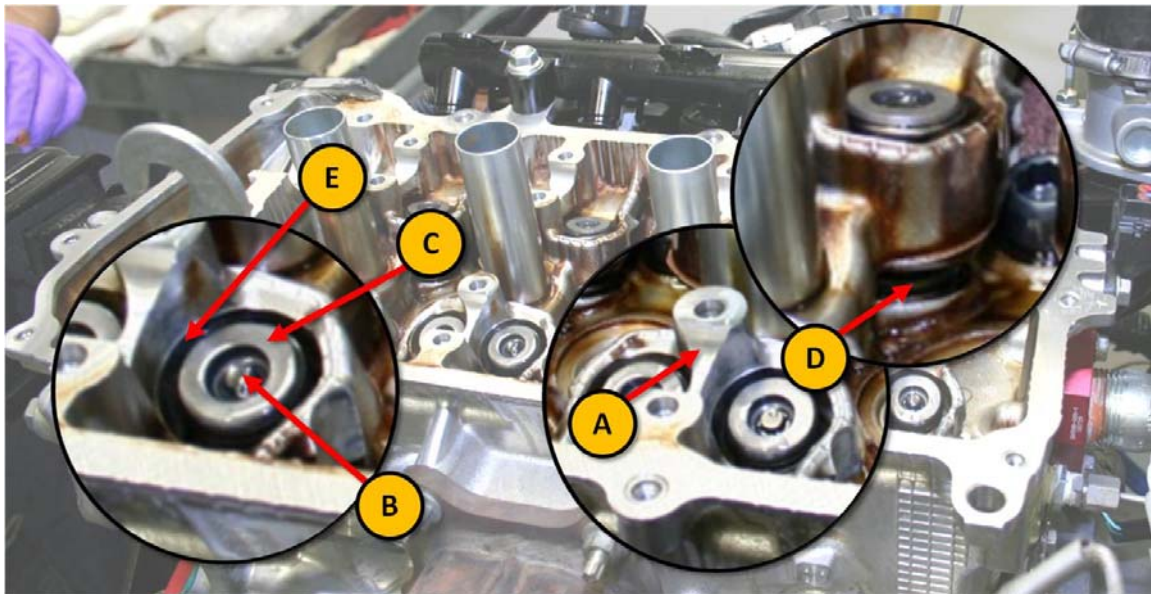

Figure 21

Refer to Figure 21:

25. Visually inspect the following areas:

- a. Camshaft bearing surfaces
- b. Valve stem tips
- c. Valve retainers and keepers
- d. Valve springs
- e. Lifter bore areas

26. Report any visual defects to the appropriate engineer for further instruction.

THIS COMPLETES THE IN-TEST CELL DISASSEMBLY AND PREPARATION FOR REASSEMBLY.

Pre-Test Measurement Procedure

Figure 22

1. Clean camshafts to be installed using degreasing solvent. Air dry with clean, dry shop air.
2. Clean camshaft bearing surfaces in the valve deck and camshaft bearing end caps with lint-free terry towels and degreasing solvent. Wipe dry with clean, dry terry towels.

Refer to Figure 22:

3. Place camshafts to be installed onto the bearing surfaces without lifters in the neutral, unloaded position.

Measuring camshaft end play

Refer to Figure 23:

4. Install the bearing end caps on intake and exhaust camshafts. Ensure the front marks (arrows) and position numbers stamped on the bearing end caps are in the order shown.

Note: Front bearing end cap is not labeled.

5. Apply a light coat of EF-411 assembly fluid to the threads and under the heads of the bearing end cap bolts.
6. Fasten bearing end cap bolts and snug lightly with 10 mm socket speed handle in the following order for both intake and exhaust camshafts: 3, 4, 2, 5. Fasten front bearing end cap bolts and snug lightly with 12 mm socket speed handle.

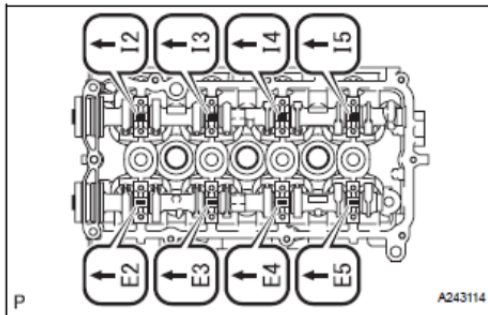

Figure 23

Refer to Figure 24:

- Using 10 mm socket torque wrench, torque bearing end cap screws to the target torque in the sequence shown. Use a 12 mm socket torque wrench for the front bearing end cap bolts. The target torques for each bolt in Table 2.

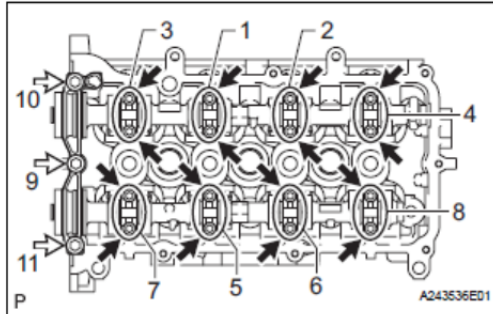

Figure 24



Figure 25

Table 2: Target torques for bearing end cap bolts

Item	Length [mm (in)]	Thread Diameter [mm (in)]	Target Torque [N-m (lbf-ft)]
Black	40 (1.57)	6 (0.236)	13 (9)
White	40 (1.57)	8 (0.315)	21 (15)

Measuring camshaft end play

Refer to Figure 25:

- Using a rubber mallet, tap the rear of the camshaft until the rear surface of the front bearing end cap is stopped against the rear flange of the first journal.
- Using a feeler gage, measure the clearance between the front flange of the first journal and the front surface of the front bearing end cap. This is the camshaft end play.
Note: Minimum camshaft end play = 0.038 mm (0.0015 in). Notify test engineer of any deviation.
- Record the intake and exhaust camshaft end play in the Engine Build Data file.

Measuring camshaft bearing clearance

11. Remove front bearing end cap bolts using 12 mm socket wrench. Remove the remaining bearing end cap bolts using 10 mm socket wrench in the following order: E5, E2, E4, E3. Remove all camshaft bearing end caps.

Refer to Figure 26:

12. Clean journal surfaces, and apply strips of Plastigage along the centerline of each camshaft journal.
13. Repeats steps 4-7 above to install camshaft bearing end caps. **DO NOT ROTATE CAMSHAFTS!**
14. Remove front bearing end cap bolts using 12 mm socket wrench. Remove all remaining bearing end cap bolts using 10 mm socket wrench in the following order: E5, E2, E4, E3. Remove all camshaft bearing end caps.

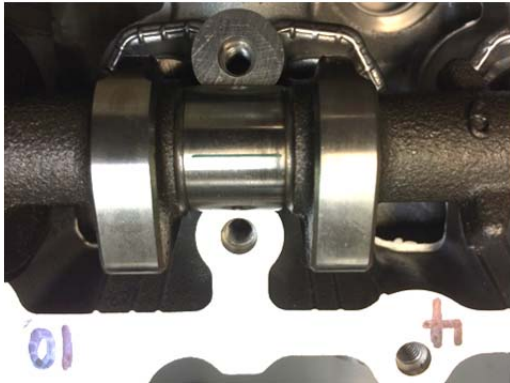

Figure 26

Refer to Figure 27:

15. Measure the bearing clearance of each journal by measuring the width of each deformed Plastigage segment. Record all clearance data in the Engine Build Data file.

Note: Standard oil clearance = 0.035 – 0.072 mm (0.001 – 0.003 in). Notify test engineer of any deviation.



Figure 27

Figure 28

16. Remove intake and exhaust camshafts. Clean off all Plastigage residue from each camshaft and bearing end caps using clean degreasing solvent. Air dry with clean, dry shop air.

This completes the pre-test measurement of camshaft end play, bearing clearances, and sprocket diameters.

Camshaft and Lifter Installation

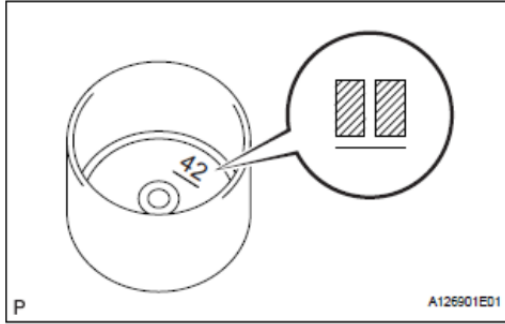

Figure 29

Refer to Figure 29:

1. Record identification numbers of the lifters to be installed in the appropriate positions on the Engine Build Data file. An example of the form used for recording lifter identification numbers is shown in Table 3, below. The lifter identification number is inscribed on the underside of the lifter.

Note: Lifter identification number is NOT the lifter size. It is a supplier serial number that is used to trace the lifters for each test.

Table 3: Example form used to record lifter ID numbers

Front of Engine		1	2	3	4	5	6	7	8	
	Intake									
	Exhaust									



Figure 30

2. Inspect all areas of the cylinder head for cleanliness, foreign objects, or debris from previous procedures. Pay close attention to the following areas for any defects:
 - a. Valve stem tips
 - b. Valve retainers
 - c. Valve springs
 - d. Lifter bores

Refer to Figure 30:

3. Apply a light coat of EF-411 assembly fluid to the valve stem tips, lifter bores, and camshaft journals.



Figure 31

Refer to Figure 31:

4. Install lifters in the appropriate positions. Rotate each lifter by hand and if any lifters appear to be tight, stop assembly and investigate / correct before continuing the assembly.



Figure 32

Refer to Figure 32:

5. Coat lifter surface at each position with EF-411 assembly fluid.



Figure 33

Refer to Figure 33:

6. Perform a visual inspection of the camshaft sprockets and resolve any issues or replace before continuing the assembly.
7. On a clean, non-marring surface, install the intake camshaft sprocket, and finger-tighten the camshaft sprocket bolt.
8. Have a second technician hold the intake camshaft in place with an adjustable wrench at the 20 mm wrench flats. The primary technician uses a 14 mm torque wrench to carefully torque the camshaft sprocket bolt to 54 Nm (40 ft-lbf).
9. Carefully lift the timing chain from within the front cover without dislodging the timing chain wedge.

Refer to Figure 34:

10. Install the timing chain onto the intake camshaft sprocket. Ensure that the chain link marked during camshaft removal coincides with the rectangular mark on the intake camshaft sprocket (A).

Note: Do not install camshaft bearing end caps at this time. Camshaft must remain free-resting in cylinder head.

11. Place the intake camshaft on the appropriate bearing surface. Rotate the camshaft until the rectangular mark (A) and the scribed mark (B) on the sprocket are in the 12 o'clock and 9 o'clock positions, respectively.

12. Install the timing chain onto the exhaust camshaft sprocket. Position the exhaust camshaft sprocket such that the rectangular mark (A) and the scribed mark (B) on the sprocket are in the 12 o'clock and 3 o'clock positions, respectively.

Note: There should be eight (8) links between the marked chain links, including the marked chain links.

13. Install the exhaust camshaft sprocket onto the exhaust camshaft. Finger-tighten the camshaft sprocket bolt only.

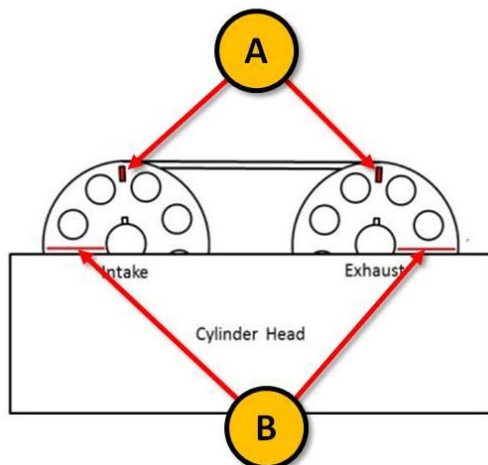

Figure 34



Figure 35



Figure 36

Refer to Figure 35:

14. Lubricate the camshafts, journals, and lifters with EF-411 assembly fluid.

Caution: Do not fill the threaded holes that receive the bearing end cap bolts with EF-411 assembly fluid. Hydraulic lock, false torque, or cracking of the cylinder head may occur.

Refer to Figure 36:

15. Lubricate camshaft bearing end caps with EF-411 assembly fluid.

16. Lubricate bearing end cap bolts with a light coat of EF-411 on the threads and underneath each bolt head. Lightly blot excess oil off the bolts.

17. Install camshaft bearing end caps.

Refer to Figure 37:

18. Using 10 mm socket torque wrench, torque each bolt in the sequence to the target torque shown in Table 4, below. Slowly and uniformly tighten the bolts in ½-turn increments following the sequence shown.

19. Using 12 mm socket torque wrench, torque each bolt in the sequence to the target torque shown in Table 4, below. Slowly and uniformly tighten the bolts in ½-turn increments following the sequence shown.

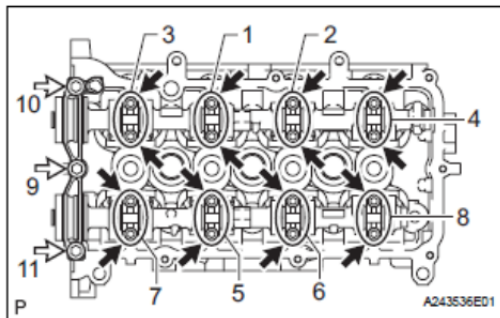

Figure 37

Table 4: Target torques for bearing end cap bolts

Item	Length [mm (in)]	Thread Diameter [mm (in)]	Target Torque [N-m (lbf-ft)]
Black	40 (1.57)	6 (0.236)	13 (9)
White	40 (1.57)	8 (0.315)	21 (15)



Figure 38

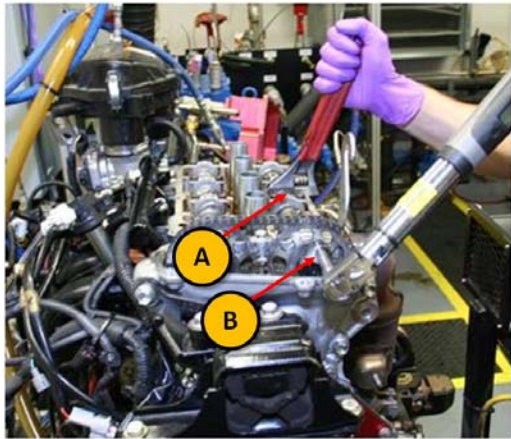

Figure 39

Refer to Figure 38:

20. Utilizing the wrench flats on the intake camshaft, turn the intake camshaft counter-clockwise to take out the timing chain slack between the camshaft sprockets. Stop once the slack is removed.

Note: Do not rotate the engine by force using the wrench flats on the camshafts.

21. Verify cylinder 1 piston is in TDC position on the compression stroke using the visual cues described in sheet 3, step 9. If the timing marks are not properly aligned, remove the exhaust camshaft sprocket and reposition the valvetrain components to obtain proper alignment.
22. Replace the timing chain tensioner with the new one (OHTIVB-13540-2) provided in the OHT camshaft kit.

Refer to Figure 39:

23. If the timing marks are properly aligned, hold the exhaust camshaft at the wrench flats with adjustable wrench (A).
 24. Using 14 mm crow's foot torque wrench (B), torque the exhaust camshaft sprocket bolt to 54 Nm (40 lbf-ft).
- Note: Do not use the timing chain to hold the sprocket while applying torque.**



Figure 40

Refer to Figure 40:

25. Remove wedge holding the timing chain tensioners. Verify alignment of timing marks.
26. Using 19 mm socket wrench, slowly rotate the engine through two complete revolutions. Verify alignment of timing marks.

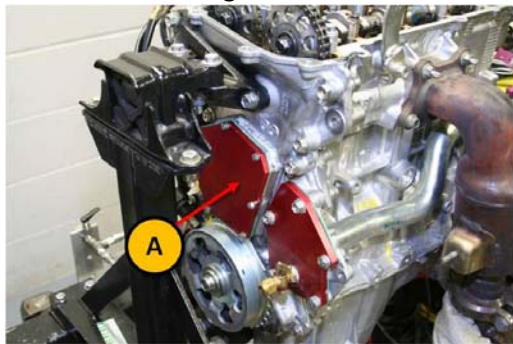

Figure 41

Refer to Figure 41:

27. Install the OHT timing chain access cover (A) (OHT p/n IVB003-3) and gasket (OHT p/n IVB003-4). Using a 8 mm socket torque wrench, torque all bolts (or nuts if studs are used) to 5 Nm (44 lbf-in).

This completes the camshaft installation procedure.

Valve Clearance Measurement

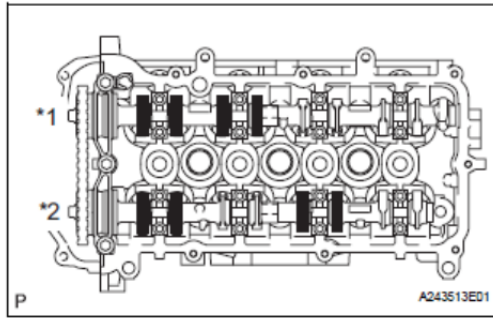

Figure 42

Refer to Figure 42:

1. Verify cylinder 1 piston is in TDC position on the compression stroke using the visual cues described in sheet 3, step 9. While the engine is in this orientation, the highlighted cam lobes can be measured for valve clearance.



Figure 43

Refer to Figure 43:

2. Using a feeler gage, measure the clearance between the lifter and cam lobe base circle. The standard valve clearances (cold) are shown in Table 5, below.

Table 5: Upper and lower limits of valve clearances

Item	Lower Limit [mm (in)]	Upper Limit [mm (in)]
Intake	0.145 (0.00571)	0.235 (0.00925)
Exhaust	0.275 (0.0108)	0.365 (0.0144)

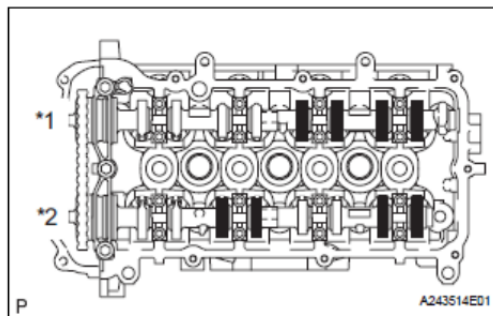

Figure 44

Refer to Figure 44:

3. Using 19 mm socket wrench, rotate the crankshaft one complete rotation to set cylinder 4 to TDC on the compression stroke. While the engine is in this orientation, the highlighted cam lobes can be measured for valve clearance.
4. Repeat step 2 to measure valve clearance for the highlighted cam lobes.

5. Record valve clearance measurements in the appropriate Engine Build Data form. An example form is shown in Table 6, below.

Table 6: Valve clearance measurements

	1	2	3	4	5	6	7	8
Intake								
Exhaust								

Intake Valve Clearance Cold: 0.145 to 0.235 mm (0.00571 to 0.00925 in)

Exhaust Valve Clearance Cold: 0.275 to 0.365 mm (0.0108 to 0.0144 in)

This completes the valve clearance measurement procedure.

Miscellaneous Engine Preparation Procedure

Refer to Figure 45:

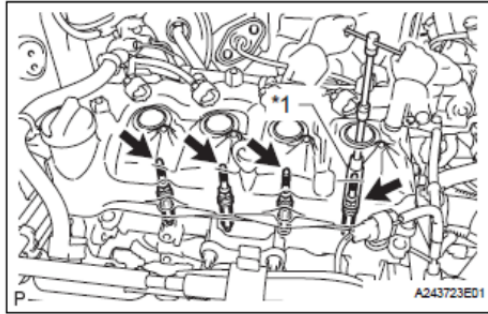

Figure 45

1. Using 16 mm spark plug socket wrench, remove and inspect spark plugs (OHT p/n OHTIVB-01258-1). Look for defects, and check spark plug gap. If any defects are noted and/or gap exceeds 1.1 mm (0.043 in), replace with new spark plug, and notify project engineer.
2. To install spark plugs, use 16 mm spark plug socket torque wrench to torque each spark plug to 18 Nm (13 ft-lbf).



Figure 46

Refer to Figure 46:

3. Inspect OHT jacketed rocker cover and O-ring (OHT p/n OHTIVB-002-1). Replace gasket if it is damaged.

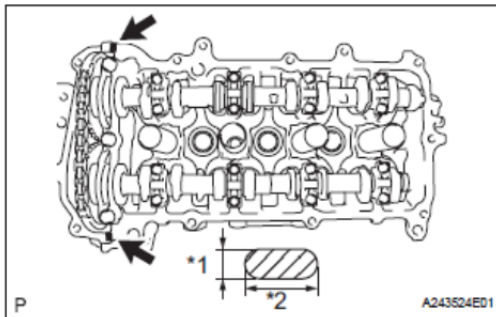

Figure 47

Refer to Figure 47:

4. Apply a small dab of RTV sealant at the mating areas indicated between the front cover and the cylinder head.

Note: The applied sealant should take up no larger than an area of 2.0 x 5.0mm (0.079 x 0.197in).



Figure 48

Refer to Figure 48:

5. Carefully install the OHT jacketed rocker cover. Ensure the spark plug tube seals properly fit over the spark plug tubes.

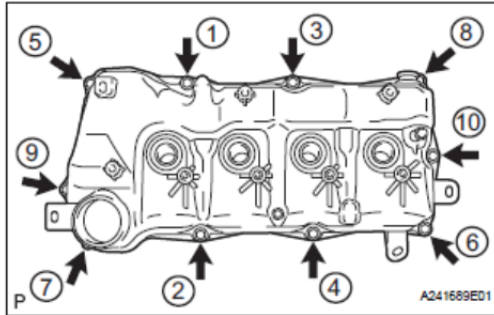

Figure 49

Refer to Figure 49:

6. Carefully align and hand-tighten the OHT jacketed rocker cover bolts.
7. Using 10 mm socket torque wrench, torque the fasteners in the sequence shown to 10 Nm (88 lbf-in). Slowly and uniformly tighten the bolts in ½-turn increments.



Figure 50

Refer to Figure 50:

8. Install the four (4) coil packs. Using 5 mm Allen drive torque wrench, torque coil pack fasteners to 5 Nm (44 lbf-in).

9. Using a 14 mm box end wrench, remove the oil drain plug (A) to allow any excess EF-411 assembly fluid to drain from the engine.
10. Re-enable the engine starter and all required test stand systems and inform lab operations.

This completes the camshaft and lifter removal and reinstallation procedure. The engine is currently ready for testing. Please refer to Engine Operations Manual, Section E for instructions on conducting the Sequence IVB test.

New Cylinder Head Assembly Procedure

Refer to Figure 1:



Figure 1

1. Obtain a new Toyota 2NR-FE cylinder head (OHT p/n OHTIVB-11101-1).
2. Wash the cylinder head in an ultra-sonic cleaner for 20-30 minutes. Air-dry with clean, compressed air.
3. Spray cylinder head with a 50/50 mixture of EF-411 assembly fluid and degreasing solvent. Air-dry with clean, dry compressed air.



Figure 2

Refer to Figure 2:

4. Obtain the set of new parts specified in Table 1. Note: Break-in valve springs should be used.
5. Apply a light coat of EF-411 assembly fluid on all valve stems.

Table 1: New parts required to complete cylinder head assembly

Item no.	Description	OHT p/n	Qty
1	Intake valve	OHTIVB-13711-1	8
2	Exhaust valve	OHTIVB-13715-1	8
3	Valve spring seat	OHTIVB-13734-1	16
4	Valve spring	OHTIVB-25063-1	16
5	Valve spring retainer	OHTIVB-13741-1	16
6	Valve spring retainer lock	OHTIVB-03028-1	32
7	Intake valve stem oil seal	OHTIVB-02101-1	8
8	Exhaust valve stem oil seal	OHTIVB-02112-1	8
9	Spark plug tubes (not shown in Figure 2)	OHTIVB-11191-1	4

6. Flip the cylinder head over, such that the top of the combustion chamber is the topside.

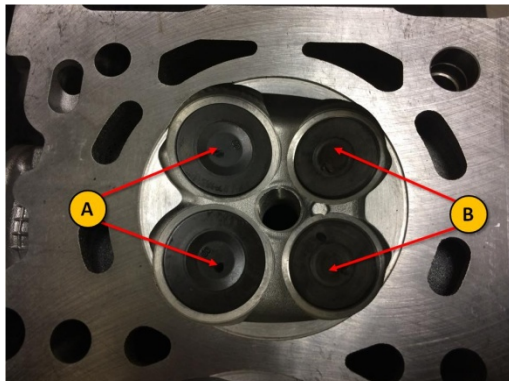

Figure 3

Refer to Figure 3:

7. Place the valves in their appropriate ports. Slide the valve stems into each valve guide. The exhaust valves are denoted as (A), and the intake valves are denoted as (B).
8. Flip cylinder head over, such that the combustion chamber is lying flat on the bench top. Ensure that the valves stay installed in the cylinder head.



Figure 4

Installing valve stem oil seals:

Refer to Figure 4:

9. Place all valve stem oil seals in a plastic container. Fill the container with EF-411 assembly fluid until the valve seals are submerged.
10. Apply a small amount of EF-411 assembly fluid on the tip of the valve stem.

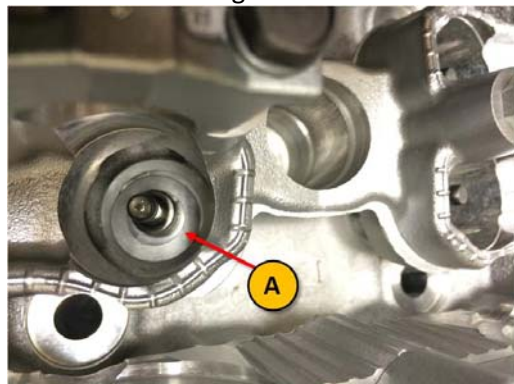

Figure 5

Refer to Figure 5:

11. Insert valve spring seat (A) onto the valve spring recess.

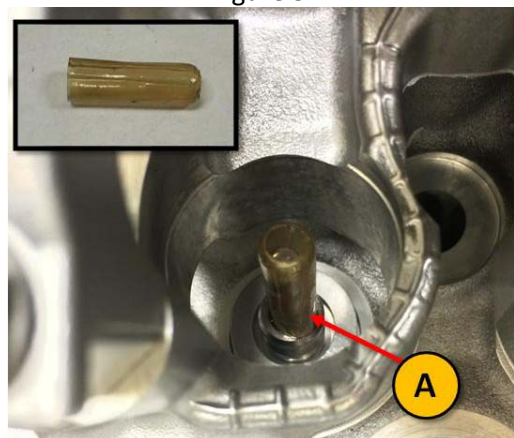

Figure 6

Refer to Figure 6:

12. Slide a 7 mm (0.276 in) OD valve stem protector (A) onto the valve stem.

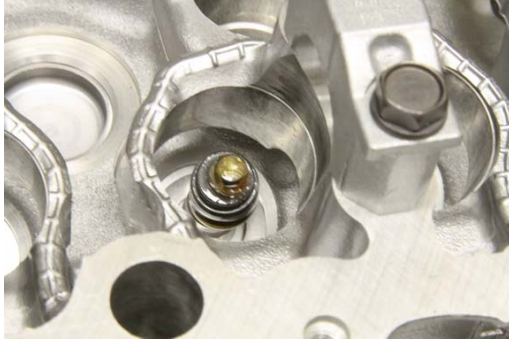

Figure 7

Refer to Figure 7:

13. Install the appropriate valve seal (bronze color for intakes, silver color for exhaust) over the valve stem protector.

Warning: Do not try to force to valve seal to seat onto the top of the valve guide by hand.



Figure 8

Refer to Figure 8:

14. Using a pair of needle nose pliers, clamp onto the tip of the valve stem protector without damaging the valve stem tip. Pull the valve stem protector out while leaving the valve seal in place.

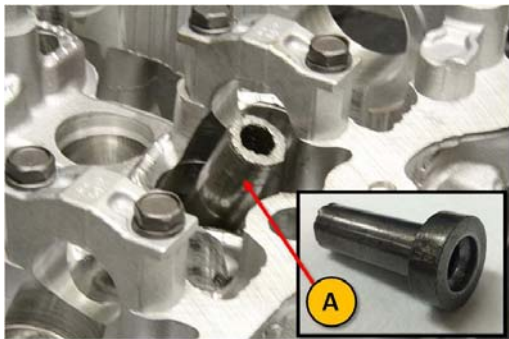

Figure 9

Refer to Figure 9:

15. Place the appropriate valve seal installation tool (A) onto the top of the valve seal.



Figure 10

Refer to Figure 10:

16. Apply force evenly on the tool to push the valve seal down.

Note: Apply force by hand; no hammering should be required for valve seal installation. The technician in Figure 10 is applying force by pushing down on the tool with the end of a hammer.

17. Repeat steps 9-15 for the other fifteen (15) valve positions.



Figure 11

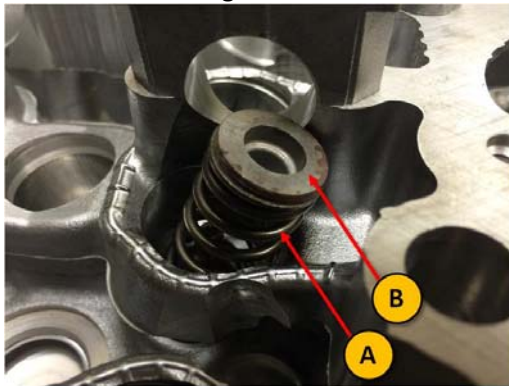

Figure 12



Figure 13



Figure 14

Installing valve springs:

Refer to Figure 11:

18. Using a 10mm socket driver adapted to a speed handle, remove all bolts securing the bearing end caps. Be sure to preserve the positions of the bearing end caps with respect to each other as they are being removed for ease of installation later.

Refer to Figure 12:

19. Place a valve spring (A) and retainer (B) into the valve spring recess.

Refer to Figure 13:

20. Place the cylinder head with the combustion chamber down onto a pneumatic valve spring press. If a valve spring press is unavailable, use the proper valve spring installation tool.

Refer to Figure 14:

21. Compress the valve spring until the valve spring retainer is below the tip of the valve stem. Apply load normal to the valve spring, which is 20° off normal along the longitudinal axis of the cylinder head.

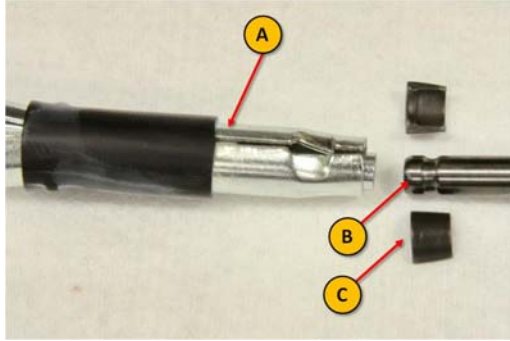

Figure 15



Figure 16



Figure 17

Refer to Figure 15:

22. Install two valve spring retainer locks (C) in the valve retainer lock installation tool (A) (Bosch p/n J-43059, or equivalent). Ensure that the wider end of the taper on the retainer lock is oriented upwards with respect to the valve stem tip (B).

Refer to Figure 16:

23. With the valve retainer lock installation tool holding onto the two halves of the retainer locks, slide the retainer locks onto the valve stem tip.

Warning: Do not release the retainer locks yet.

Refer to Figure 17:

24. Decompress the valve spring. As the retainer moves upwards and receives the retainer locks, release the valve retainer lock installation tool.

Note: When the valve spring is in its installed state, the valve spring retainer should be holding the retainer locks in place at the valve stem tip.

25. Repeat steps 18-23 for remaining fifteen (15) valve springs.

26. Reinstall the bearing end caps in their appropriate positions. Hand-tighten the bearing end cap bolts.

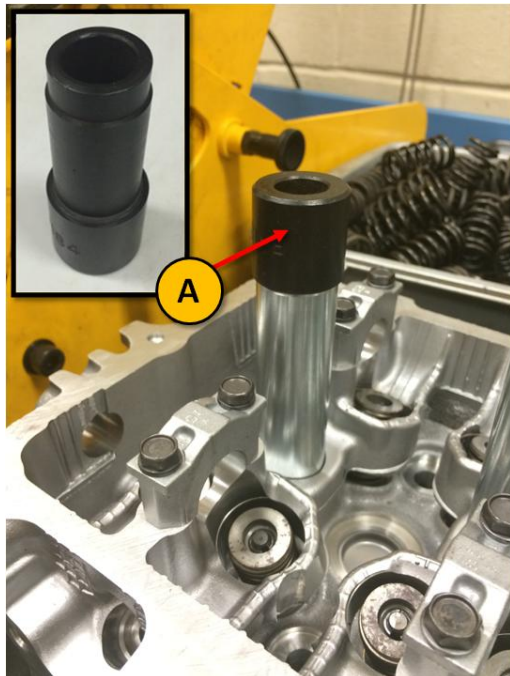

Figure 18



Figure 19

Installing spark plug tubes:

27. Apply a light coat of EF-411 assembly fluid at one end of the spark plug tube.
28. Hold the lubricated end of the spark plug tube in contact with the corresponding recess in the cylinder head.

Refer to Figure 18:

29. Place the installation tool (A) onto the open end of the spark plug tube.

Refer to Figure 19:

30. Hit the tool with a hammer to drive the spark plug tube into the recess. Stop hammering when the spark plug tube reaches the bottom of the recess.

Cylinder Head Removal Procedure

This procedure is to be conducted in the event that the installed cylinder head needs to be replaced with a new cylinder head. This procedure proceeds with the assumption that the camshaft and valve lifters have been removed. If this has not been completed, please refer to Section 2 of the Toyota Engine Assembly Manual for instructions on removing the camshaft and lifters.

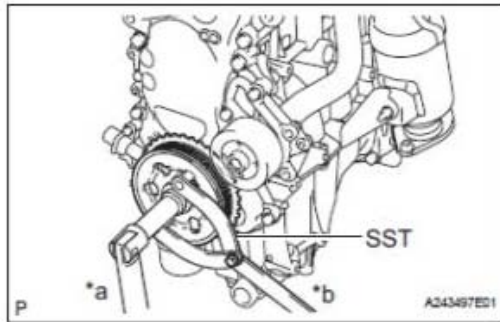

Figure 20

Refer to Figure 20:

1. Using a crankshaft pulley installation tool (OHT p/n OHTIVB-10010-1), hold the crankshaft pulley to prevent the engine from rotating.
2. Using a 19 mm socket wrench, remove the crankshaft pulley bolt.
3. Remove crankshaft pulley.



Figure 21

Refer to Figure 21:

4. Using a 14 mm socket wrench, remove the wiring harness ground (A) at the rear of the cylinder head.

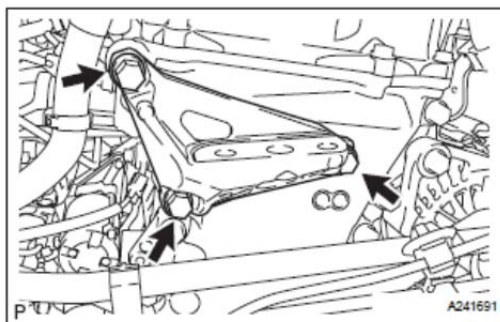

Figure 22

Refer to Figure 22:

5. Using a 14 mm socket wrench, remove the three (3) bolts that hold the engine mounting bracket to the OHT modified front cover (OHT p/n OHTIVB-003-1).

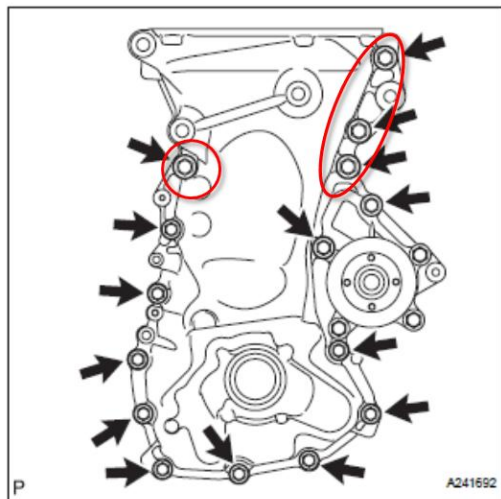

Figure 23

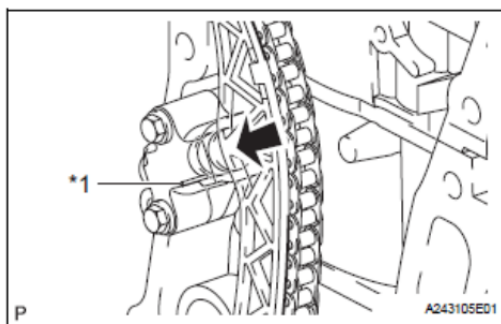

Figure 24

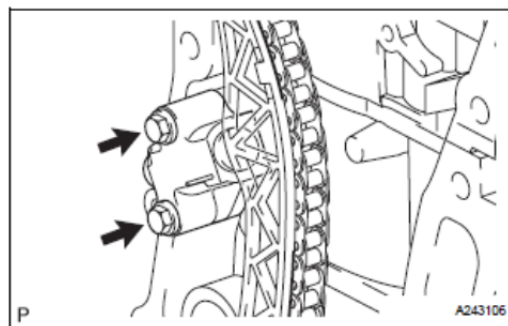

Figure 25

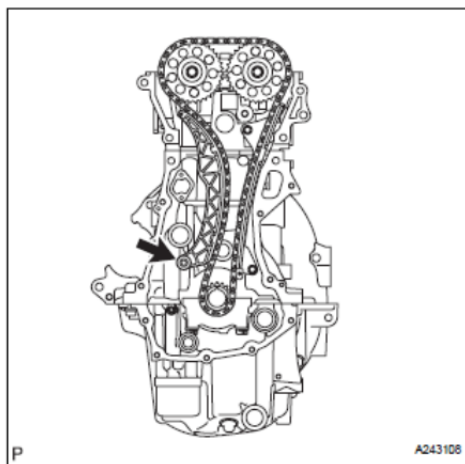

Figure 26

Refer to Figure 23:

6. Using the appropriate socket wrench, remove the thirteen (13) bolts on the engine front cover. The four (4) circled bolts must be removed with a 14 mm socket wrench. The remaining nine (9) bolts must be removed with a 10 mm socket wrench.

Note: Stock front cover is displayed in Figure 23 for illustration purposes only. OHT modified front cover should be used.

7. Remove the OHT front cover and O-ring.

Refer to Figure 24:

8. Remove the plastic wedge that is forcing the timing chain tensioners apart.
9. Push the plunger (marked with an arrow) into the timing chain tensioner.
10. Insert a 1.2mm (0.0472in) diameter pin into the hole (marked with a "1") to lock the plunger.

Refer to Figure 25:

11. Using a 10 mm socket wrench, remove the two (2) bolts holding the timing chain tensioner to the engine block.
12. Remove the timing chain tensioner.
13. Remove and discard the underlying timing chain tensioner gasket.

Refer to Figure 26:

14. Using a 10 mm socket wrench, remove the bolt holding the timing chain tension arm to the engine block (marked with an arrow).
15. Remove the timing chain tension arm.

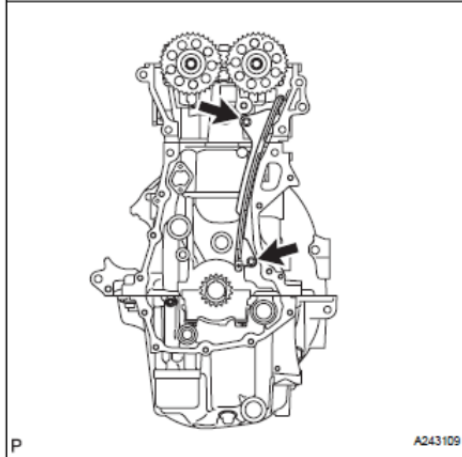

Figure 27

Refer to Figure 27:

16. Using a 10 mm socket wrench, remove the two (2) bolts holding the timing chain guide to the engine block (marked with two arrows).
17. Remove the timing chain tensioner.
18. Remove the timing chain.

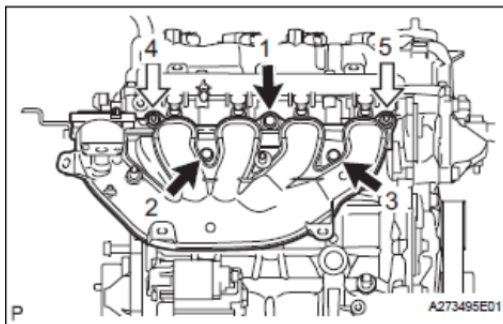

Figure 28

Refer to Figure 28:

19. Using a 12 mm socket wrench, remove the three bolts (black arrows) and two nuts (white arrows) that hold the intake manifold to the cylinder head.
20. Remove the intake manifold, and place it securely on the engine stand.
21. Remove and discard the intake manifold gasket.

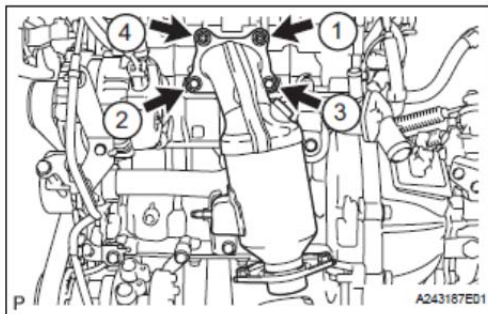

Figure 29

Refer to Figure 29:

22. Using a 12 mm socket wrench, remove the two bolts (OHTIVB-80825-1) and two nuts (OHTIVB-08228-1) that hold the exhaust pipe assembly to the cylinder head.
23. Remove the exhaust pipe assembly (note: Figure 29 shows the stock assembly but the OHT modified part OHTIVB-17400-1 should be used), and place it securely on the engine stand.
24. Remove and discard the exhaust manifold gasket.

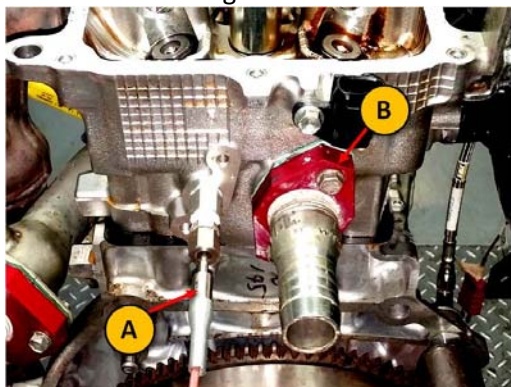

Figure 30

Refer to Figure 30:

25. Using a 10 mm box-end wrench, loosen the compression fitting nut that holds the engine coolant out thermocouple (A).
26. Remove the engine coolant out thermocouple.
27. Remove the OHT engine coolant out hose barb adapter plate (OHT p/n OHTIVB-005-1) (B).

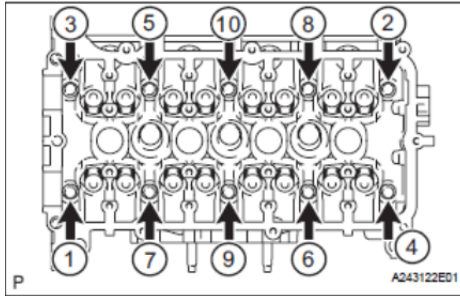

Figure 31

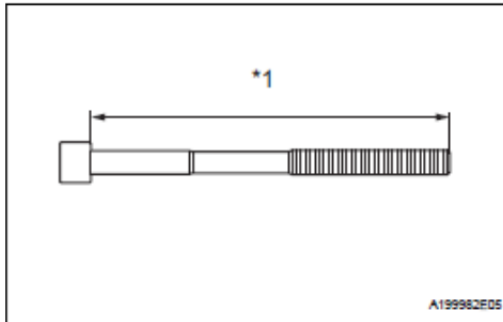

Figure 32

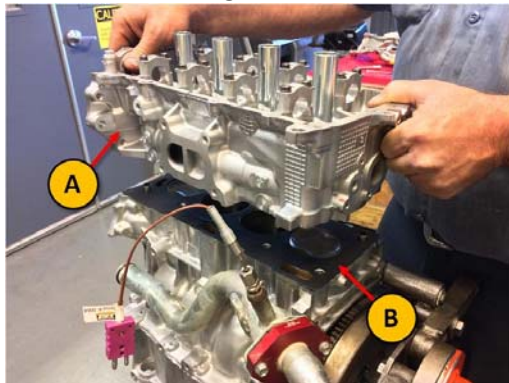

Figure 33



Figure 34

Refer to Figure 31:

28. Using a 10mm bi-hexagonal drive wrench, loosen the ten (10) head bolts in the sequence shown. Loosen in at least three (3) quarter-turn steps.

29. Remove head bolts and plate washers.

Refer to Figure 32:

30. Using a vernier caliper, measure the length of the head bolt, as indicated. The bolt length is not to exceed 128.2mm (5.01in). Discard the head bolt if it exceeds the maximum limit. Replace with a new head bolt (Toyota p/n 90910-02174).

Refer to Figure 33:

31. Remove cylinder head (A).

32. Remove and discard cylinder head gasket (B).

Refer to Figure 34:

33. Using a metal pick, carefully scrape carbon deposits off the piston tops.

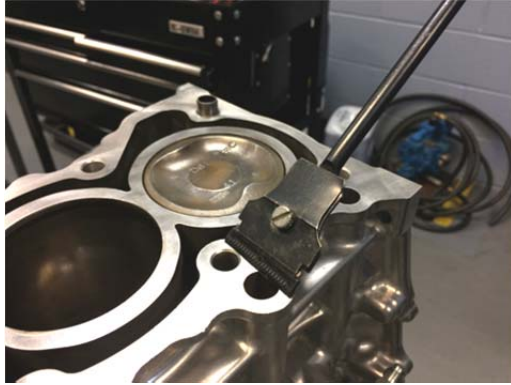

Figure 35

Refer to Figure 35:

34. Using a plastic scraper, scrape off any residual gasket material, silicone, and/or carbon deposits from the cylinder head deck surface and front cover surface.

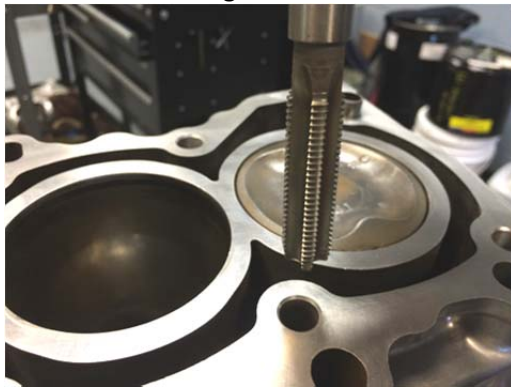

Figure 36

Refer to Figure 36:

35. Using a M10x1.5 tap bit, clean the head bolt hole threads in the engine block.
36. Spray degreasing solvent into each bolt hole. Air-dry each bolt hole with clean, dry compressed air. Ensure that no debris remains within each hole.

Cylinder Head Installation Procedure

Figure 36

Refer to Figure 36:

1. Install a new cylinder head gasket (OHT p/n OHTIVB-11115-1) in the orientation shown. Ensure that all cylinder head bolt holes on the gasket are aligned with those on the cylinder head deck surface.

2. Place the new cylinder head on top of the head gasket.

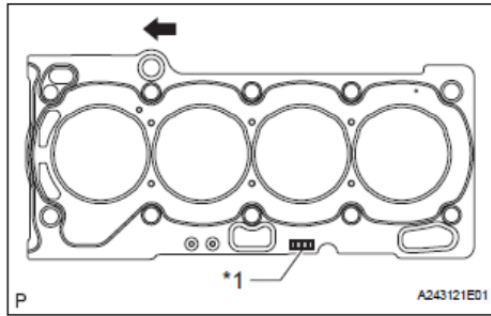
3. Apply a light coat of EF-411 assembly fluid to the threads of the ten (10) cylinder head bolts.

Refer to Figure 37:

4. Install the ten (10) cylinder head bolts and ten (10) plate washers into the cylinder head. Using a 10mm bi-hexagonal drive torque wrench, tighten the cylinder head bolts uniformly in several steps in the sequence shown. The target torque is 32 Nm (24 ft-lbf).

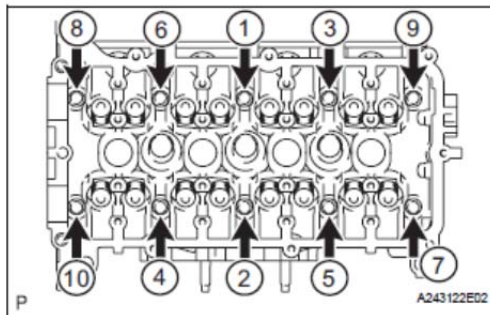

Figure 37

5. Using a 10mm bi-hexagonal drive wrench, further tighten each cylinder head bolt by one quarter turn in the sequence shown.

6. Repeat step 6 to turn each bolt one more quarter turn.

Refer to Figure 38:

7. Install two (2) studs (OHT p/n OHTIVB-08060-1) in the intake side of the cylinder head at the indicated positions.



Figure 38

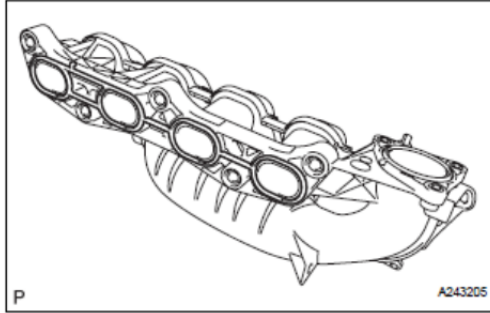

Figure 39

Refer to Figure 39:

8. Install a new intake manifold gasket (OHT p/n OHTIVB-17177-1) on the intake manifold.

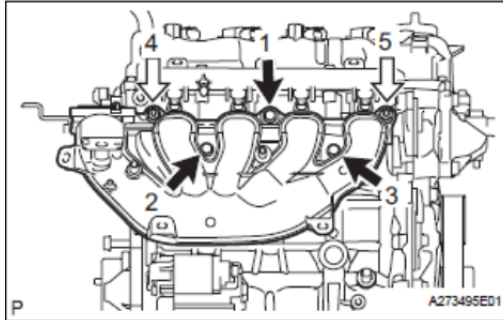

Figure 40

Refer to Figure 40:

9. Install the intake manifold with three (3) bolts (black arrows) and two (2) nuts (white arrows). Using a 12 mm socket torque wrench, tighten the bolts and nuts to the target torque in the sequence indicated. The target torque is 21 Nm (15 ft-lbf).

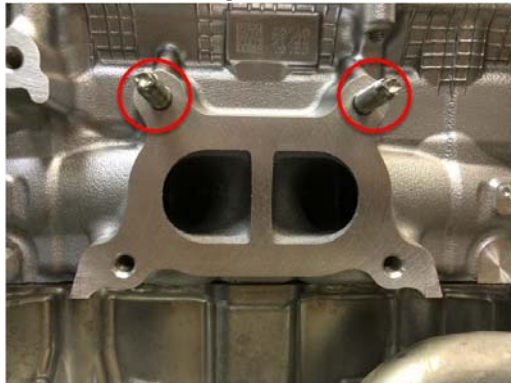

Figure 41

Refer to Figure 41:

10. Install two (2) studs (OHT p/n OHTIVB-08052-1) in the exhaust side of the cylinder head at the indicated positions.

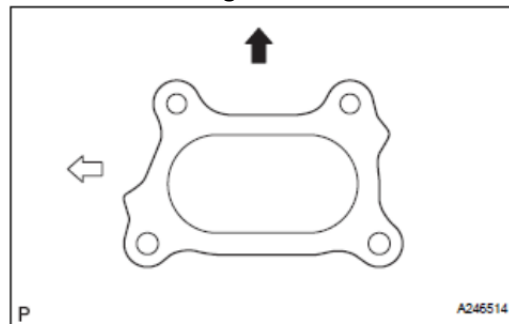

Figure 42

Refer to Figure 42:

11. Install a new exhaust manifold gasket (OHT p/n OHTIVB-17173-1) on the exhaust manifold in the indicated orientation. The black arrow indicates vertical direction, and the white arrow indicates the direction to the front of the engine.

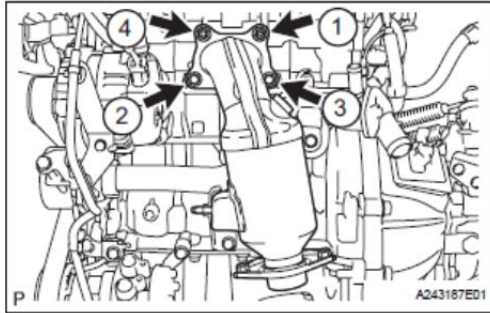

Figure 43

Refer to Figure 43:

12. Install the exhaust manifold with two (2) bolts (numbers) and two (2) nuts (numbers). Using a 12 mm socket torque wrench, tighten the bolts and nuts to the target torque in the sequence indicated. The target torque is 27 Nm (20 ft-lbf).

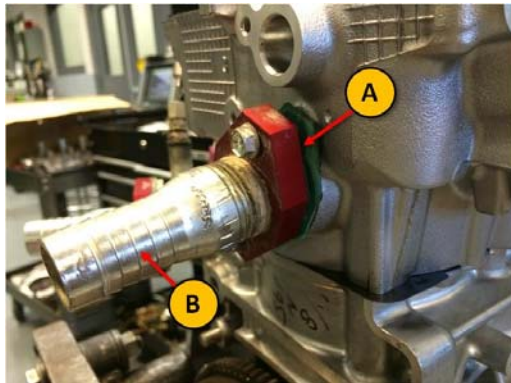

Figure 44

Refer to Figure 44:

13. Install a new gasket (A) for the OHT engine coolant out hose barb adapter plate (B).
14. Install the OHT engine coolant out hose barb adapter plate with two (2) bolts. Using a 10 mm socket torque wrench, tighten the bolts to the target torque. The target torque is 10 Nm (7 ft-lbf).
15. Install the engine coolant out thermocouple. Using a 1/2 in box-end wrench, tighten the compression fitting nut that holds the engine coolant out thermocouple until snug.
16. Follow the instructions in Section 2, Camshaft and Lifter Installation Procedure to install a set of camshafts and lifters used for break-in purposes. Install a new set of intake and exhaust camshaft sprockets (OHT p/n OHTIVB-13523-1).

Note: Some trial and error will be required to select the appropriate lifter grades.

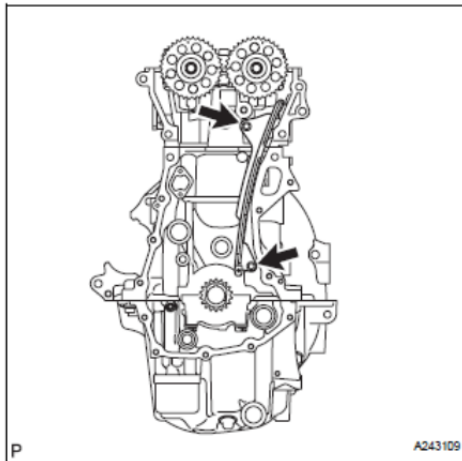

Figure 45

Refer to Figure 45:

17. Install the new timing chain guide (OHT p/n OHTIVB-13566-1) to the engine block with two (2) bolts (marked with arrows). Using a 10 mm socket torque wrench, tighten the two (2) bolts holding the timing chain guide to 10 Nm (7 ft-lbf).

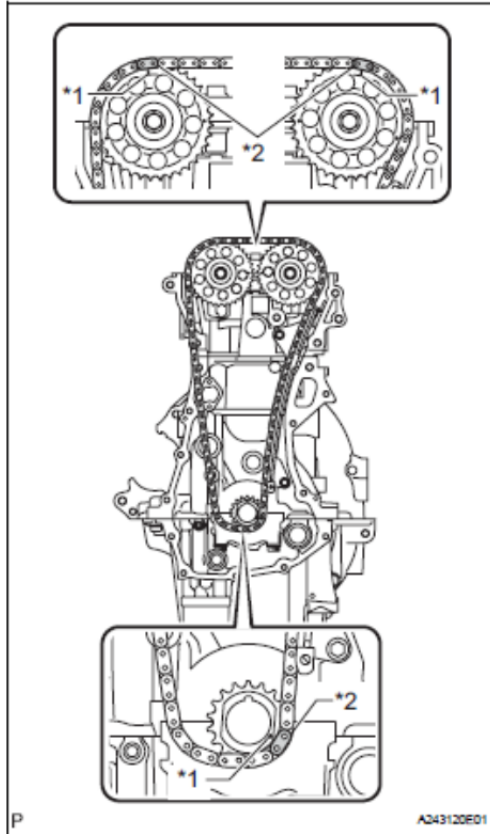

Figure 46

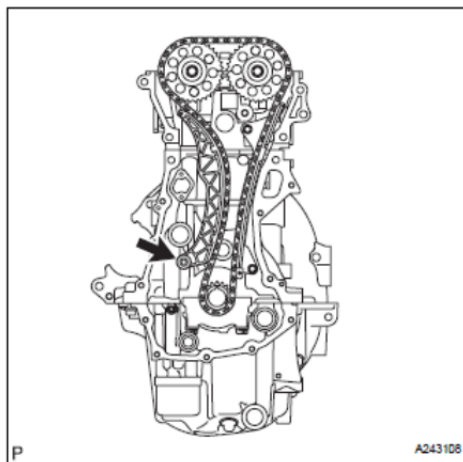
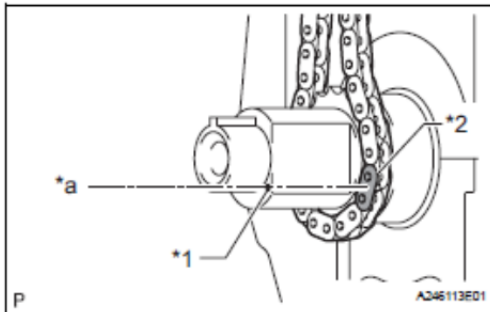

Figure 47

Refer to Figure 46:

18. Arrange the camshaft sprockets such that the rectangular timing marks are approximately vertical. Arrange the crankshaft sprocket such that the flat edges are vertical.

19. Wrap a new timing chain (OHT p/n OHTIVB-13506-1) around the camshaft and crankshaft sprockets. The colored links on the chain should line up with both camshaft sprocket timing marks.

Note: With cylinder 1 in TDC on the compression stroke, the marked plate on the timing chain should be approximately in the position shown.

Refer to Figure 47:

20. Install a new timing chain tension arm (OHT p/n OHTIVB-13591-1) with a bolt (marked with arrow). Using a 10 mm socket torque wrench, torque the bolt holding the timing chain tension arm to 10 Nm (7 ft-lbf).

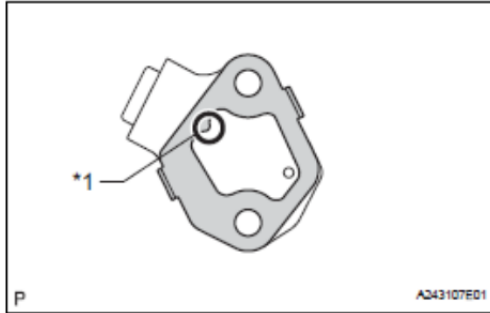

Figure 48

Refer to Figure 48:

21. Install a new timing chain tensioner gasket (OHT p/n OHTIVB-13552-1) on the timing chain tensioner.

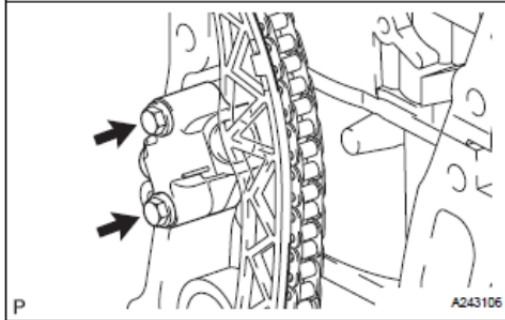

Figure 49

Refer to Figure 49:

22. Install the timing chain tensioner with two (2) bolts. Using a 10 mm socket torque wrench, tighten the two (2) bolts holding the timing chain tensioner to the engine block to 10 Nm (7 ft-lbf).

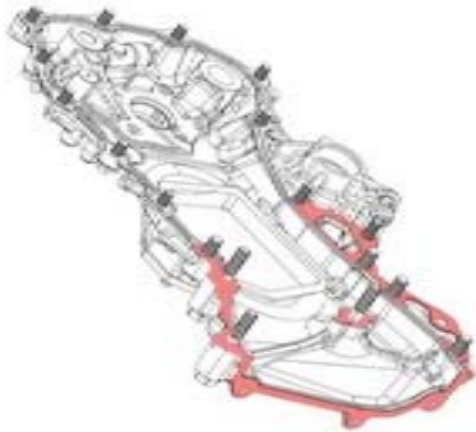

Figure 50

Refer to Figure 50:

23. Install a new O-ring (OHT p/n IVB003-2) in the O-ring groove on the OHT front cover (OHT p/n OHTIVB-003-1). A suitable adhesive, such as petroleum jelly, may be used to hold the O-ring in place.
24. Apply Toyota Three Bond Black 1282B, or equivalent RTV sealant, on the highlighted areas.

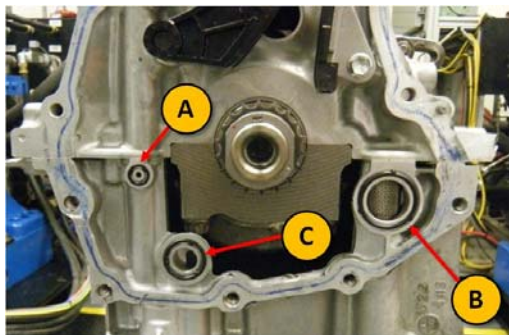

Figure 51

Refer to Figure 51:

25. Install a gasket and O-rings in the locations indicated in Table 2, below.

Table 2: Locations to install gasket and O-rings at front of oil pan

Location	Description	OHT p/n
A	O-ring	OHTIVB-09031-1
B	O-ring	OHTIVB-27014-1
C	Gasket	OHTIVB-19023-1

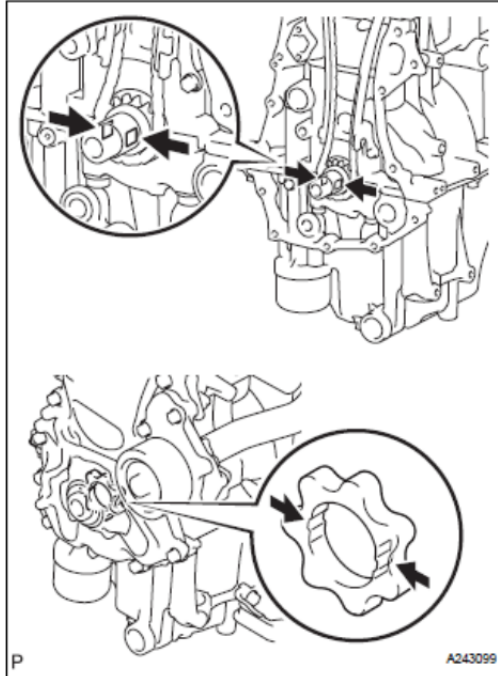

Figure 52

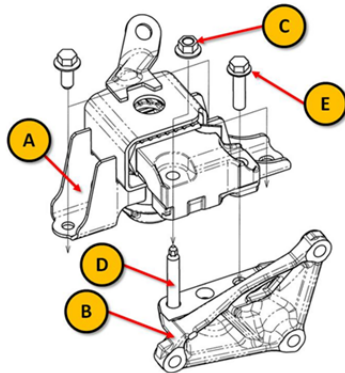

Figure 53

Refer to Figure 52:

- 26. Ensure the spline in the oil pump gear is aligned, such that one is pointed left and the other is pointed right while the flat edges on the crankshaft sprocket are oriented vertically.

- 27. Install the front engine mount insulator (A) (OHT p/n OHTIVB-12305-1) on the front engine mount (B) on the engine. Secure with flanged bolt (E) (OHT p/n OHTIVB-10469-1). Note the stud (D) is no longer part of the sub-assembly
- 28. Using a 14 mm socket torque wrench, torque the nut and bolt to 52 Nm (38 lbf-ft).

Refer to Figure 54:

- 29. Install the OHT front cover on the engine with fifteen (15) bolts. The dimension of each bolt is shown in Table 3, below. Hand-tighten only.

Table 3: Dimensions of front cover bolts

Bolt	Length [mm (in)]	Thread Diameter [mm (in)]
A and E	25 (0.984)	8 (0.315)
B	40 (1.57)	10 (0.394)
C	40 (1.57)	8 (0.315)
D	70 (2.76)	10 (0.394)

Note: Apply Toyota Three Bond 1324, or equivalent, adhesive to the threads of Bolt E.

Note: Stock front cover is displayed in Figure 54 for illustration purposes only. OHT modified front cover should be used.

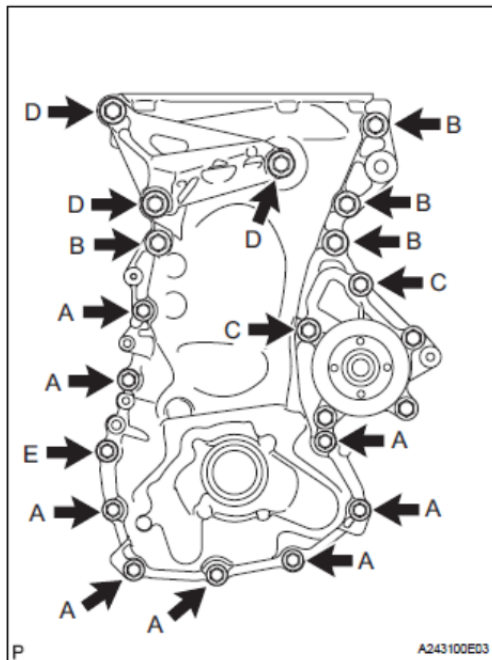

Figure 54

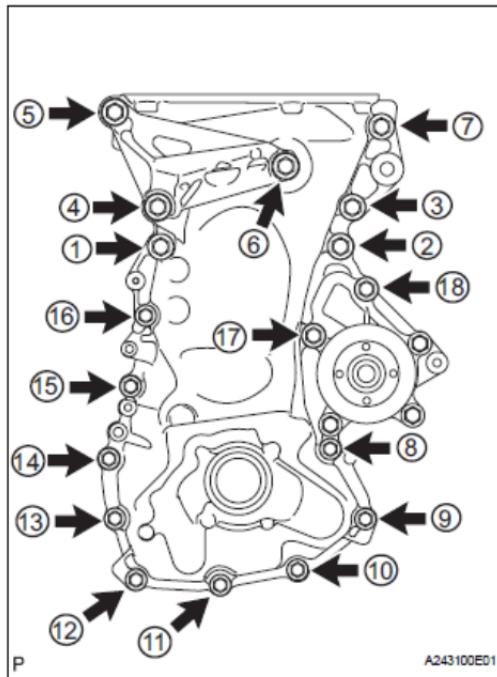

Figure 55

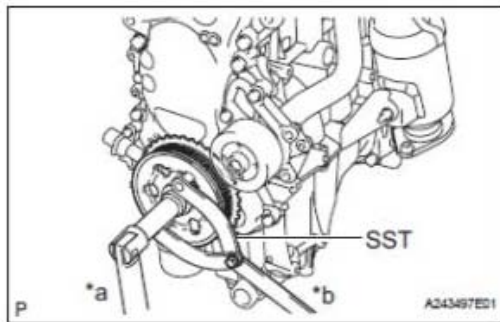

Figure 56



Figure 57

Refer to Figure 55:

30. Using the appropriate socket drive adapted to a torque wrench, tighten the eighteen (18) bolts on the timing chain cover to the target torque in the sequence indicated. The target torque for each bolt is listed in Table 4.

Table 4: Target torques for each front cover bolt

Bolt	Target Torque [Nm (ft-lbf)]
A, C, E	24 (18)
B, D	51 (38)

Note: Stock front cover is displayed in Figure 55 for illustration purposes only. OHT modified front cover should be used.

Refer to Figure 56:

31. Align the set key on the crankshaft pulley with the key groove in the crankshaft. Slide the crankshaft pulley onto the crankshaft.
32. Using a crankshaft pulley installation tool (OHT p/n OHTIVB-10010-1), hold the crankshaft pulley to prevent the engine from rotating.
33. Using a 19 mm socket torque wrench, install the crankshaft pulley bolt by tightening to 164 Nm (121 ft-lbf).

Refer to Figure 57:

34. Mount the wiring harness ground (A) at the rear of the cylinder head. Using a 10 socket torque wrench, torque the mounting bolt to 14 Nm (10 lbf-ft).

This concludes the cylinder head installation procedure. The engine is now ready to undergo the break-in and silicone pacification procedure. Refer to Section D of the Sequence IVB Operations Procedure for instructions to conduct the break-in and silicone pacification.

Test Intake Valve Spring Installation Procedure

This procedure is to be conducted after a cylinder head has completed the engine break-in and silicone pacification procedure in Section D of the Sequence IVB Operations Procedure. The objective is to remove the intake valve springs used during the break-in procedure and to install stiffer test intake valve springs. The procedure detailed in this section can be conducted with the engine on the test stand or removed and placed on an engine build-up stand.

1. After the break-in and silicone pacification procedure has been completed, follow instructions in Section 2 of the Toyota Engine Assembly Manual to remove the intake and exhaust camshafts.

Note: Ensure plastic wedge is firmly in place within the timing chain access port to keep the timing chain tensioners from collapsing on the timing chain.

2. Using visual cues ensure the piston in cylinder 1 is located at the top-dead-center (TDC) position on the compression stroke. The list of visual cues is detailed in Section 2 of the Toyota Engine Assembly Manual.

Note: The mechanic can check for TDC by inserting a long plastic rod into the open spark plug port. Make sure that the rod is long enough to extend beyond the top of the spark plug tubes. Turn the crankshaft slowly, and watch the rising and falling of the tip of the rod. Stop turning when the tip reaches the apex of its travel. The top of the piston should be approximately 168mm (6.61in) from the top of the spark plug hole.

Warning: When rotating the crankshaft, ensure the timing chain is always in tension to keep the chain links engaged with the crankshaft sprocket. Pull upwards on the timing chain segment exposed at the cylinder head area while rotating the crankshaft to maintain tension in the chain. This is to prevent damage at an extrusion underneath the crankshaft sprocket on the OHT front cover.



Figure 58

Refer to Figure 58:

Note: The following procedure details valve spring removal using the Snap-On YA8845 Valve Spring Compressor Tool. However, any equivalent portable valve spring compressor tool can be used for this procedure.

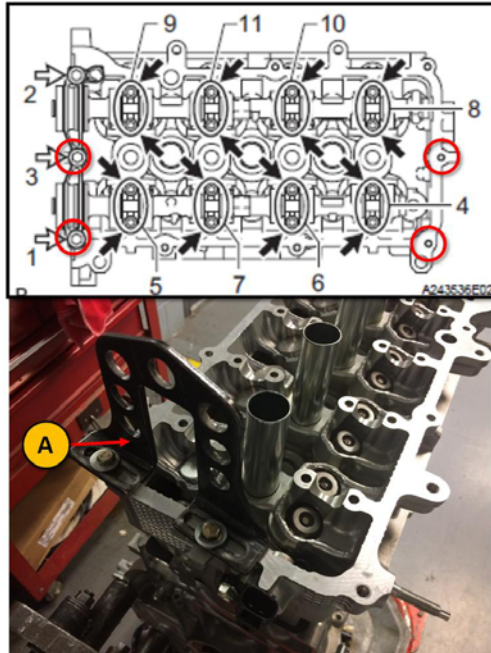

Figure 59

Refer to Figure 59:

3. Mount the fulcrum posts (A) at the front and rear ends of the cylinder head using the bolt holes circled in red. Use M6x1.0 bolts.

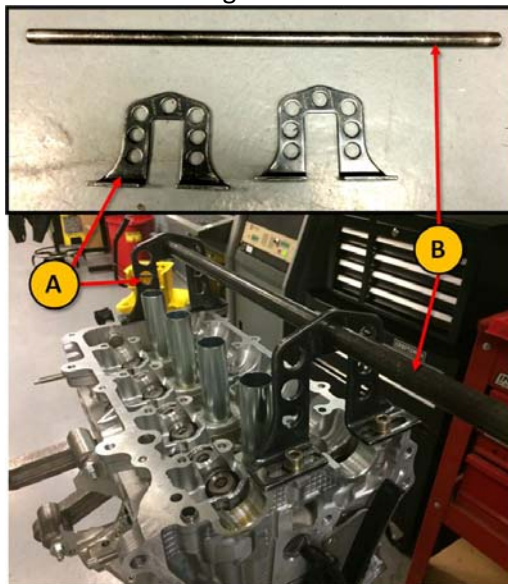

Figure 60

Refer to Figure 60:

4. Place fulcrum rod (B) through the topmost holes in the fulcrum posts (A).

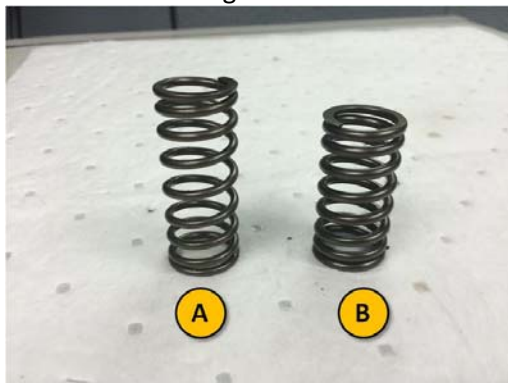

Figure 61

Refer to Figure 61:

5. Obtain eight (8) Sequence IVB intake valve springs (OHT p/n OHTIVB-30034-1) (B). Note the difference between a stock valve spring (OHT p/n OHTIVB-25063-1) (A).

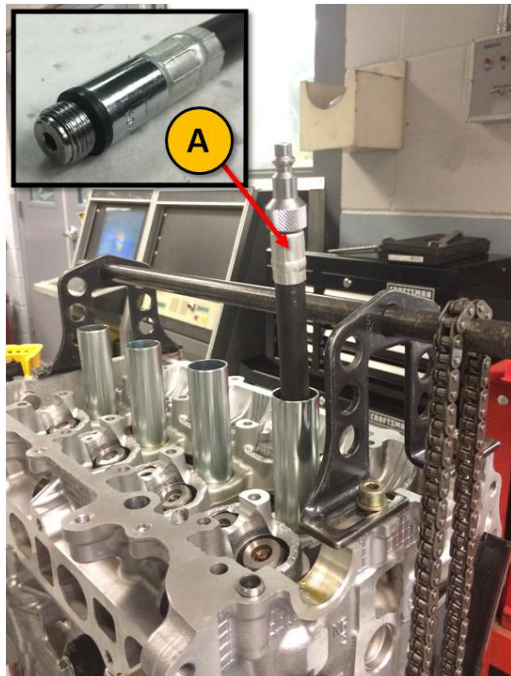

Figure 62

Refer to Figure 62:

6. Hang the timing chain on the fulcrum rod.
7. Attach an air line with the correct adapter for the spark plug port (A) to the cylinder 1 spark plug port.
8. Pressurize cylinder 1 with dry, clean compressed air.
Warning: If the piston is too far off the TDC position, the compressed air will suddenly push the piston downwards and rotate the crankshaft. Therefore, it is very important that step 2 is strictly followed.

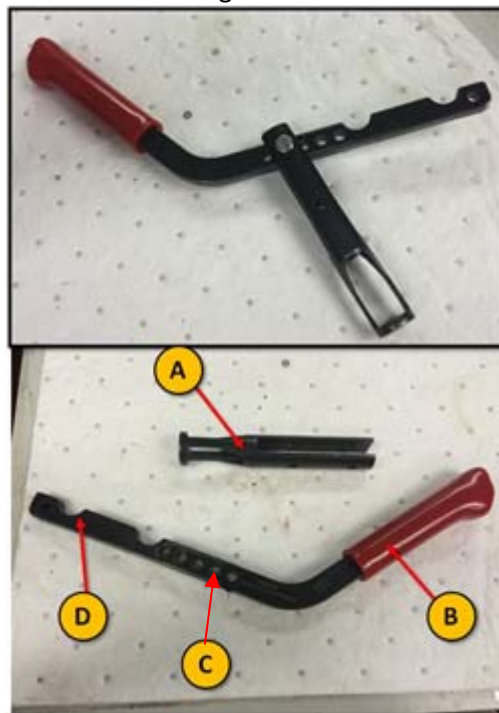

Figure 63

Refer to Figure 63:

9. Connect valve compressor load arm (A) with the valve compressor lever (B) using the second bolt hole from the handle (C).

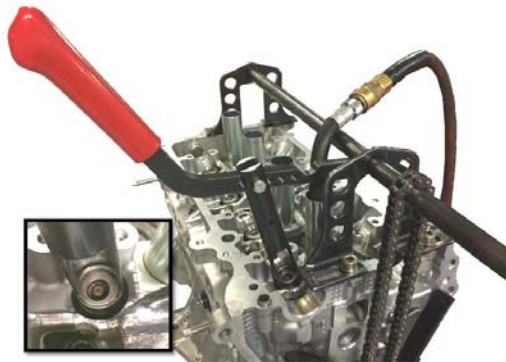

Figure 64

Refer to Figure 64:

10. Mount the compressor load arm on the fulcrum rod. Use the notch on the lever arm that is furthest away from the handle, (D) in Figure 6. The lever arm from the fulcrum to the connection to the load arm should be approximately 100mm. Ensure the load bearing surface of the load arm is making even contact with the top surface of the valve spring retainer (inset) for intake position 1 (closest to the front of the engine). In this configuration, the load arm should be applying even force normal to the top surface of the retainer.



Figure 65

Refer to Figure 65:

11. Pull down on the lever to compress the valve spring until the valve stem tip is above the top surface of the valve spring retainer. The retainer locks should fall off the valve tip.
12. Pick up the retainer locks with a magnetic tool.
13. Remove the valve spring and the retainer.
14. Place a Sequence IVB intake valve spring (OHTIVB-30034-1) in place of the stock valve spring.



Figure 66

Refer to Figure 66:

15. Place valve spring retainer locks into the recess of the valve spring retainer. Ensure that the larger ends of the taper on the retainer locks are oriented towards the top surface of the retainer.
16. Place the valve retainer with the retainer locks on top of the valve spring.



Figure 67

Refer to Figure 67:

17. Place index finger on top of the valve spring retainer to keep the retainer locks from being pushed out by the valve stem tip.



Figure 68

Refer to Figure 68:

18. Pull down on the valve compressor lever to compress the valve spring until the valve stem tip is above the top surface of the valve spring retainer. Allow the valve stem tip to slide upwards between the retainer locks until the extrusions in the retainer locks are roughly at the same vertical level as the receiving grooves in the valve stem tip.

19. Slowly and carefully decompress the valve spring. As the retainer moves upwards, it should receive the retainer locks and secure them within the tapered recess.

Note: When the valve spring is in its installed state, the valve spring retainer should be holding the retainer locks in place at the valve stem tip.

20. Move the valve compressor tool in position to the next intake valve position. Repeat steps 10-19 for the next valve position.

Note: The intake valve spring positions are designated from 1 to 8, with position 1 being closest to the front of the engine. The test intake valve springs should be installed in the following sequence: 1, 2, 7, 8. When moving from position 2 to position 7, the compressed air line should be moved from the cylinder 1 to cylinder 4 spark plug port.

21. Rotate the crankshaft 180°.

22. Using the technique detailed in step 2 to ensure that the piston in cylinder 2 is at the TDC position.

23. Move the compressed air line from cylinder 4 to cylinder 2. Repeat steps 10-20 to install the test valve springs for positions 3, 4, 5,6, in that order.

This concludes the test intake valve spring installation procedure. The cylinder head is now ready to be used for Sequence IVB testing. For installation of test camshafts, please refer to Section 2 of the Toyota Engine Assembly Manual.