



This document is not an ASTM standard; it is under consideration within an ASTM technical committee but has not received all approvals required to become an ASTM standard. You agree not to reproduce or circulate or quote, in whole or in part, this document outside of ASTM Committee/Society activities, or submit it to any other organization or standards bodies (whether national, international, or other) except with the approval of the Chairman of the Committee having jurisdiction and the written authorization of the President of the Society. If you do not agree with these conditions please immediately destroy all copies of the document. Copyright ASTM International, 100 Barr Harbor Drive, West Conshohocken, PA 19428. All Rights Reserved.



Date: 9/5/17
To: Subcommittee D02.BO
Tech Contact: E. A. Hap Thompson
Work Item #: WK50202
Ballot Action: New of the Sequence IV Test Method
Rationale: A new passenger car engine oil classification has been approved and this is a new standard.

Standard Test Method for Evaluation of Automotive Engine Oils in the Sequence IVB Spark-Ignition Engine¹

This standard is issued under the fixed designation DXXXX; the number immediately following the designation indicates the year of original adoption or, in the case of revision, the year of last revision. A number in parentheses indicates the year of last reappraisal. A superscript epsilon (ϵ) indicates an editorial change since the last revision or reappraisal.

INTRODUCTION

Portions of this test method are written for use by laboratories that make use of ASTM Test Monitoring Center (TMC)² services (see Annex A1).

The TMC provides reference oils and engineering and statistical services to laboratories that desire to produce test results that are statistically similar to those produced by laboratories previously calibrated by the TMC.

In general, the Test Purchaser decides if a calibrated test stand is to be used. Organizations such as the American Chemistry Council require that a laboratory utilize the TMC services as part of their test registration process. In addition, the American Petroleum Institute and the Gear Lubricant Review Committee of the Lubricant Review Institute (SAE International) require that a laboratory use the TMC services in seeking qualification of oils against their specifications.

The advantage of using the TMC services to calibrate test stands is that the test laboratory (and hence the Test Purchaser) has an assurance that the test stand was operating at the proper level of test severity. It should also be borne in mind that results obtained in a non-calibrated test stand may not be the same as those obtained in a test stand participating in the ASTM TMC services process.

Laboratories that choose not to use the TMC services may simply disregard these portions.

1. Scope

1.1 This test method measures the ability of crankcase oil to control valve-train wear for spark-ignition engines at low operating temperature conditions. This test method is designed to simulate extended engine cyclic vehicle operation. The Sequence IVB Test Method uses a Toyota 2NR-FE water cooled, 4 cycle, in-line cylinder, 1.5 liter engine. The primary result is bucket lifter wear. Secondary results include cam lobe nose wear and measurement of iron wear metal concentration in the used engine oil. Other determinations such as fuel dilution of the crankcase oil, non-ferrous wear metal concentrations, total fuel consumption, and total oil consumption, can be useful in the assessment of the validity of the test results.²

¹ This test method is under the jurisdiction of ASTM Committee D02 on Petroleum Products, Liquid Fuels, and Lubricants and is the direct responsibility of Subcommittee D02.B0 on Automotive Lubricants.

Current edition approved X X, 201X. Published X 201X. Originally approved in 201X. Last previous edition approved in 201X as DXXXX. DOI: 1X.XXXX/DXXXX.

² The ASTM Test Monitoring Center will update changes in this test method by means of Information Letters. Information letters may be obtained from the



1.2 The values stated in SI units are to be regarded as standard. No other units of measurement are included in this standard.

1.2.1 *Exceptions*—Where there is no direct SI equivalent such as pipe fittings, tubing, NPT screw threads/diameters, or single source equipment specified.

1.3 *This standard does not purport to address all of the safety concerns, if any, associated with its use. It is the responsibility of the user of this standard to establish appropriate safety and health practices and determine the applicability of regulatory limitations prior to use.* See **Annex AX** for specific safety precautions.

2. Referenced Documents

2.1 ASTM Standards:³

- D235 Specification for Mineral Spirits (Petroleum Spirits) (Hydrocarbon Dry Cleaning Solvent)
- D287 Test Method for API Gravity of Crude Petroleum and Petroleum Products (Hydrometer Method)
- D323 Test Method for Vapor Pressure of Petroleum Products (Reid Method)
- D381 Test Method for Gum Content in Fuels by Jet Evaporation
- D445 Test Method for Kinematic Viscosity of Transparent and Opaque Liquids (and Calculation of Dynamic Viscosity)
- D525 Test Method for Oxidation Stability of Gasoline (Induction Period Method)
- D664 Test Method for Acid Number of Petroleum Products by Potentiometric Titration
- D2622 Test Method for Sulfur in Petroleum Products by Wavelength Dispersive X-ray Fluorescence Spectrometry
- D3525 Test Method for Gasoline Diluent in Used Gasoline Engine Oils by Gas Chromatography
- D4739 Test Method for Base Number of Petroleum Products by Potentiometric Titration
- D5185 Test Method for Multielement Determination of Used and Unused Lubricating Oils and Base Oils by Inductively Coupled Plasma Atomic Emission Spectrometry (ICP-AES)
- D6304 Test Method for Water content in Petroleum Products by x
- E230 Specification and Temperature-Electromotive Force (EMF) Tables for Standardized Thermocouples
- IR 5.8 6.1 Infrared Spectra Oxidation and Nitration Peak Area

2.6 GMNA Standards:

GM6277M⁴ Extended Life Automotive, Concentrate – Ethylene Glycol

2.7 Other Standards:

Sequence IVB Engine Assembly Manual

Sequence IVB Keyence VR-3200 Procedure REMOVE, THIS PROCEDURE WILL BE INCLUDED IN SECTION 12

Comment [k1]: What standard or procedure in being used at each lab?

Comment [k2]: To be updated following the scheduled metrology workshop.

Comment [k3]: Section 12?

Comment [k4]: Included as Annex

3. Terminology NOTE: MANY DEFINITIONS NEED TO BE ADDED. D6891 WAS LACKING. Do you mean we need to add this standard to the Reference Documents? If so, where do we use it in the text?

3.1 Definitions:

3.1.1 *blowby, n*—that portion of the combustion products and unburned air/fuel mixture that leaks past piston rings into the engine crankcase during operation.

3.1.2 *calibration test stand, n*—a test stand on which the testing of reference material(s), conducted as specified in the standard, provided acceptable results. **Sub. B Glossary**¹⁰

3.1.2.1 *Discussion*—In several automotive lubricant standard test methods, the ASTM Test Monitoring Center provides

ASTM Test Monitoring Center (TMC), 6555 Penn Ave., Pittsburgh, PA 15206-4489, Attention: Administrator. www.astmtmc.emu.edu. This edition incorporates all Information Letters through No. 13-1.

³ For referenced ASTM standards, visit the ASTM website, www.astm.org, or contact ASTM Customer Service at service@astm.org. For *Annual Book of ASTM Standards* volume information, refer to the standard's Document Summary page on the ASTM website.

⁴ Available from from IHS Markit, 25 Ropemaker St., London, EC2Y 9LY, United Kingdom



testing guidance and determines acceptability.

3.1.3 *reference oil, n*—an oil of known performance characteristics, used as a basis for comparison.

3.1.3.1 *Discussion*—Reference oils are used to calibrate testing facilities, to compare the performance of other oils, or to evaluate other materials (such as seals) that interact with oils.

3.2 *Definitions of Terms Specific to This Standard:*

3.2.1 *aging, n*—engine operation at steady state after completion of break-in, to pacify silicon leaching from gasket and seal material.

3.2.2 *break-in, n*—initial engine operation to reach stabilization of the engine performance after new parts are installed in the engine.

3.2.3 *lifter volume loss, n*—the difference between the post-test and pre-test volume of a valve-train bucket lifter as measured by a Keyence VR-3000 or later model 3D macroscope.

3.2.3.1 *Discussion*—The pass fail criteria is the average intake lifter volume loss, the average volume loss of all intake 8 lifters. The average exhaust lifter volume loss is also calculated.

3.2.4 *cam lobe wear, n*—the difference between pre-test and post-test measurement of a cam lobe from heel to nose in μm .

3.2.5 *golden stand, n*—Sequence IVB test stand built in accordance with the ASTM DXXXX Sequence IVB test method by the approved supplier(s).

3.2.6 *lifter area loss, n*

3.2.7 *flushing, n*—the installation of a fresh charge of lubricant and oil filter for the purpose of running the engine to reduce and eliminate remnants of the previous oil charge.

3.2.7.1 *Discussion*—Flushing may be carried out in an iterated process to ensure a more thorough process of reducing previous oil remnants.

3.2.8 *reference plane, n*—The depth above which volume is calculated for Keyence volume measurements.

3.2.9 *lifter crown, n*—the maximum difference in height measured along to reference axis of the bucket lifters.

3.2.10 *camshaft lobe failure, n*—A severe form of wear of a camshaft lobe surface, that influences engine operation and makes it impossible to complete a test.

3.2.10.1 *Discussion*—Tests that experience camshaft lobe failure are considered non-interpretable because the phenomenon does not have a repeatable relationship with test oil.

3.2.11 *Degreasing Solvent*—Mineral spirits meeting the requirements of Specification D235, Type II, Class C for Aromatic Content (0 to 2) vol %, Flash Point (61 °C, min) and Color (not darker than +25 on Saybolt Scale or 25 on Pt-Co Scale).

(Warning-Combustible. Health hazard.) A Certificate of Analysis is required for each batch of solvent.

3.2.12 *Keyence VR Macroscopic*—A wide area optical 3D measurement device produced by the Keyence Corporation used to generate volume loss wear results for Sequence IVB tests.

4. Summary of Test Method

4.1 *Test Numbering Scheme*—Use the test numbering scheme shown below:

AAAAA-BBBBB-CCCCC

AAAAA represents the stand number. BBBB represents the number of tests since the last calibration test on that stand. CCCCC represents the total number of Sequence IVB tests conducted on that stand. For example, 6-10-175 represents the 175th Sequence IVB test conducted on test stand 6 and the tenth test since the last calibration test. Consecutively number all tests. Number the stand calibration tests beginning with zero for the BBBB field. Multiple-length Sequence IVB tests are multiple runs for test numbering purposes, such as double-length tests which are counted as two runs and triple-length tests which are counted as three runs. For example, if test 1-3-28 is a doubled-length test, number the next test conducted on that stand 1-5-30.

4.2 *Test Engine*—This procedure uses a Toyota 2NR-FE water cooled, 4 cycle, in-line four cylinder, 1.5 L engine as the test apparatus. The engine incorporates dual overhead camshafts, four valves per cylinder (2 intake; 2 exhaust), and a direct acting mechanical bucket lifter valve-train design. The critical test parts (camshafts, direct acting mechanical bucket lifters) are replaced prior to each test. A 95 min break-in schedule, followed by a 50 h aging schedule, for Silicon (Si) pacification, is conducted whenever the long block or cylinder head are replaced with new components, or the long block is rebuilt due to camshaft lobe failure.

4.3 *Test Stand*—The complete test stand is available from the Test Engineering Inc. Thermocouples are to be installed by individual test labs at the locations are shown in Annex A7. Mount the engine so that there is a 4.5° incline from the exhaust to the intake side and an angle of 0° from front to back. Control the intake air, provided to the engine air filter housing, for temperature, pressure, and humidity. Control the backpressure of the exhaust leaving the engine. Install the engine on a test

Comment [k5]: Yes, we agreed to 50 hours.



stand equipped with computer control of engine speed, torque, various temperatures, pressures, flows, and other parameters outlined in the test procedure (see Section 11).

4.4 *Test Sequence*—After an engine run-in and aging schedule, or after the completion of a previous test, install new test camshafts and bucket lifters, spark plugs, and a new timing chain tensioner. Flush the external oil system with solvent and the oil pan with EF-411 using external pumps and connections. Perform four engine flushes, using fresh oil charges for each flush. After completing the fourth flush, drain and install the fresh test oil charge. Run the test for a total of 200 h, with no scheduled shutdowns. A single test cycle is composed of two 7-s steady-state stages separated by 8-s transitions. This test cycle (two steady-state stages and two transitions) is repeated 24,000 times.

4.5 *Analyses Conducted*—At the completion of the test, the camshaft lobes are measured for heel-to-toe wear and the bucket lifters are measured for volume loss, ~~and mass loss~~. Use these measurements to determine the ~~summation of~~ average, minimum and maximum wear for the intake and exhaust bucket lifters and the intake and exhaust camshaft lobes. Determine the oil consumption by calculating the difference between the mass of the used drain oil and the mass of the engine's initial oil charge considering oil removed for intermediate oil samples. Analyze the end of test used oil for wear metals, fuel dilution, kinematic viscosity at 40°C, total acid number, total base number, oxidation and nitration by FTIR, and Karl Fischer water content. Retain a final drain sample of 1 L for a minimum of 90 days. Retain the camshafts and bucket lifters for a minimum of 6 months.

5. Significance and Use

5.1 This test method was developed to evaluate automotive lubricant's effect on controlling camshaft lobe and bucket lifter wear for overhead camshaft engines with direct acting bucket lifters.

NOTE 1—This test method may be used for engine oil specifications such as API X and ILSAC GF 6.

6. Apparatus

NOTE 2—Coordination with the ASTM Committee D02, Subcommittee B, Sequence IV Surveillance Panel is a prerequisite to the use of any equivalent apparatus. Figures are provided throughout the test method to suggest appropriate design details and depict some of the required apparatus.

6.1 *Test Engine*—This test method uses a 2011 model Toyota 2NR-FE, in-line 4-cylinder, 16 valve, 4-cycle, water-cooled, port fuel-injected gasoline engine with a displacement of 1.496 L. See Annex A9 for a parts lists. Nominal oil sump volume is 3 L. The cylinder block and cylinder head is aluminum. The engine features dual overhead camshafts and direct acting bucket lifters. The engine compression ratio is 10.5 to 1. The engine is rated to 132 N·m of torque at 3000 r/min. The ignition timing and multi-port fuel injection system is electronically controlled by a test-specific ECM.

6.1.1 *Engine Buildup Area*—~~The ambient atmosphere of the engine buildup and measurement areas shall be reasonably free of contaminants and maintained at a uniform temperature. Maintain the specific humidity at a uniform level to prevent the accumulation of rust on engine parts. Use uniform temperatures and background luminous intensity to ensure repeatable dimensional measurements. Use a Keyence microscope on a base-plate free of external vibrations.~~

Comment [k6]: Two points

6.1.2 *Measurement Area*—~~Use uniform temperatures and background lighting to ensure repeatable dimensional measurements. Use a Keyence microscope on a base-plate free of external vibrations.~~

Comment [k7]: Two points

6.1.3 *Engine Operating Area*—The laboratory ambient atmosphere shall be reasonably free of contaminants and general wind currents, especially if the valve-train parts are installed while the engine remains in the operating area. The temperature and humidity level of the operating area is not specified.

6.1.4 *Parts Cleaning Area*—This test method does not specify the ambient atmosphere of the parts cleaning area (**Warning**—Use adequate ventilation in areas while using solvents and cleansers).

6.2 *External Engine Modifications*—Modify the test engine for the valve-train wear test. Install the modified front cover and oil pan from the approved supplier. Install an oil filter adapter at the location of the stock oil filter housing, as shown in the Sequence IVB Engine Assembly Manual Section 1. Install fittings for various temperature and pressure measurements as required by the test method. Replace the Toyota production rocker arm cover with a specially manufactured aluminum jacketed rocker arm cover (part# OHTIVB-002-1). Route the rocker arm cover coolant through this jacket.

6.3 *Test Stand and Laboratory Equipment*—This engine-dynamometer test is designed for operation using computer control instrumentation and computer data acquisition. Provide an intake air system for the precise control of engine intake air humidity, temperature, and cleanliness.



6.3.1 Computer *Data Acquisition System*—The procedure shown in 6.3.1.1 – 6.3.1.3 details the test stand log operational data with a computer data acquisition system using sensor configurations, and complies with Data Acquisition and Control Automation II⁵. Consider a test that has greater than 2 h without data acquisition on any controlled parameter to be operationally invalid.

6.3.1.1 *Frequency of Logged Data*—Log data at 1 Hz during all 4 stages of all test cycles.

6.3.1.2 *Resolution of Logged Data*—The laboratory provided data acquisition system must provide 32 analog to digital channels that meet the resolution requirements in Table 1.

6.3.1.3 *System Time Response for Logged Data*—Do not exceed the controlled operational parameters for system time response for measurement shown in Table 2. The system time response includes the total system of sensor, transducer, analog signal attenuation, and computer digital filtering. Use single-pole type filters for attenuation.

TABLE 1 Data Acquisition Resolution Requirements

Parameter	Units	Required Resolution
Engine Speed	r/min	1
Torque	N-m	1
Air-to-Fuel Ratio	afr	0.05
All Temperatures Except Exhaust	°C	0.1
Exhaust Temperature	°C	1
All Gauge Pressures	kPaG	0.1
Barometer	KpaA	0.1
Humidity	g/kg	0.01

TABLE 2 System Time Response

Parameters	Time Response, max (one-time constant)
Temperatures	2.8 s
Pressures	1.7 s
Coolant Flow	2.5 s?
Torque	2.0 s
Speed	1.8 s

Comment [k8]: Flow meter power supply change? A dedicated power supply is suggested.

6.3.1.4 *Quality Index*—The Quality Index (QI) is an overall statistical measure of the variation from test targets of the steady-state operational controlled parameters. The Sequence IVB Surveillance Panel has chosen the QI upper and lower control limits, shown in Table 3.

$$QI = 1 - \frac{1}{n} \sum_{i=1}^n \left(\frac{U+L - 2X_i}{U-L} \right)^2 \quad (1)$$

where:

X_i = values of the parameter measured,

U = allowable upper limit of X ,

L = allowable lower limit of X , and

⁵ ASTM TMC Technical Guidance Committee Report available referenced on www.asmtmc.cmu.edu



n = number of data points used to calculate QI.

TABLE 3 QI Control Limits

Parameter	U	L
Intake Air Humidity	12.00	11.00
Engine Coolant Out Temperature	53.5	50.5
Exhaust Backpressure *	107.50	101.50
Fuel Rail Temperature	24.50	23.50
Intake Air Pressure	0.50	0.00
Intake Air Temperature	32.75	31.25
Oil Gallery Temperature	58.00	50.00
RAC Coolant Out Temperature	20.75	19.25
Torque	26.50	23.50
Engine Coolant Flow Rate	80.40	79.60
RAC Coolant Flow Rate	120.75	119.25
Blow-by Gas Temperature	29.50	28.50
Load Cell Temperature	49.00	41.00
Engine Coolant Pressure	80.00	60.00
Fuel Rail Pressure	345.00	325.00

*Only calculated during stage 2

TABLE 4 Engine Speed (Variable Target) QI Control Limits

Cycle Time, s	Setpoint, rpm	U, rpm	L, rpm
1	800	950	650
2	800	900	700
3	800	875	725
4	800	850	750
5	800	850	750
6	800	850	750
7	800	850	750
8	927	1077	777
9	1357	1607	1107
10	1888	2288	1488
11	2300	2700	1900
12	2731	3131	2331
13	3168	3568	2768
14	3610	4010	3210
15	4041	4441	3641
16	4300	4400	4200



17	4300	4375	4225
18	4300	4350	4250
19	4300	4325	4275
20	4300	4325	4275
21	4300	4325	4275
22	4300	4325	4275
23	4136	4236	4036
24	3734	3984	3484
25	3283	3683	2883
26	2829	3229	2429
27	2382	2782	1982
28	1946	2346	1546
29	1523	1923	1123
30	1116	1516	716

TABLE 5 BQD Limits

Parameter	U	L
Intake Air Humidity	20.00	1.00
Engine Coolant Out Temperature	195.00	0.00
Exhaust Backpressure *	200.00	0.00
Fuel Rail Temperature	195.00	0.00
Intake Air Pressure	5.00	-1.00
Intake Air Temperature	195.00	0.00
Oil Gallery Temperature	195.00	0.00
RAC Coolant Out Temperature	195.00	0.00
Engine Speed	5500.00	0.00
Torque	200.00	0.00
Engine Coolant Flow Rate	200.00	0.00
RAC Coolant Flow Rate	200.00	0.00
Blow-by Gas Temperature	195.00	0.00
Load Cell Temperature	195.00	0.00
Engine Coolant Pressure	200.00	0.00
Fuel Rail Pressure	500.00	0.00

Where missing data or Bad Quality Data (BQD), or both, are encountered, calculate the adjusted Quality Index (QI_{ADJ}) using the following equation:

$$QI_{ADJ} = QI\left(\frac{n}{N}\right) + QI\left(\frac{n}{N}\right) \times \left(\frac{N - n}{N}\right) \quad (2)$$

Comment [k9]: Must decide o also including on limits for excluded points or time



where:

Q = QI calculated without missing/BQD,

I = points,

n = number of data points used to calculate QI, and

N = number of data points for a complete data set.

If the QI calculation of a controlled parameter is less than zero, investigate the reason, assess its impact on test operational validity, and document such finding in the final test report. For calibration tests, review the operational validity assessment with the TMC. Annex A2 describes calibration procedures using the TMC reference oil, including their storage and conditions of use, the conducting of tests and the reporting of results.

6.3.2 *Test Stand Configuration*—Mount the engine on the test stand like its vehicle orientation (0° in front; sideways 4.5° up on intake manifold side). This orientation is important to the return flow of oil in the cylinder head, and ensures reproducible oil levels. Directly couple the engine flywheel to the Midwest MW1014A dynamometer through the approved driveshaft.

6.3.3 *Dynamometer Excitation and Throttle Control*—A DyneSystems Non-Interlock 5 which is provided as part of the golden stand assembly is the only system permitted to be used for dynamometer excitation and throttle control.

6.3.4 *Intake-air Supply System*—The intake air supply system shall deliver at least 1000 L/min (2000 L/min preferred) of conditioned and filtered air to the test engine during the 200 h test, while maintaining the intake-air parameters detailed in [Table A.2](#).

6.3.4.1 *Induction Air Humidity*—Measure the intake air specific humidity in the main system duct or at the test stand. If using a main system duct dew point temperature reading to calculate the specific humidity, verify the dew point periodically at the test stand. Maintain the duct surface temperature above the dew point temperature at all points downstream of the humidity measurement point to prevent condensation and loss of humidity level.

6.3.4.2 *Intake Air Filtering*—Use the production intake air cleaner assembly with filter, at the engine. Use a snorkel adapter of that fits over the intake air box inlet to connect the controlled air duct to the air cleaner. Ensure that the top of the air cleaner assembly has been modified for installation of the intake pressure sensor line. Refer to 6.3.4.5 for installation position

6.3.4.3 *Intake Air Flow*—Do not measure for intake airflow.

6.3.4.4 *Intake Air Temperature*—For final control of the inlet air temperature, install an electric air heater strip within the air supply duct. The duct material and heater elements design shall not generate corrosion debris that could be ingested by the engine.

6.3.4.5 *Intake Air Supply Pressure*—Locate the pressure sensing tube on the top cover of the air cleaner $190 \text{ mm} \pm 10 \text{ mm}$ from the front (straight edge of the top surface) and $65 \text{ mm} \pm 10 \text{ mm}$ from the left (viewed from the front of the box). The tube ~~should~~ shall have a depth of $25 \text{ mm} \pm 4 \text{ mm}$ into the air cleaner.

6.3.5 *Fuel Supply System*—This test method requires approximately 750 L of unleaded Haltermann KA24E Green test fuel per test (24000 cycles). A fuel supply pressure of at least 124 kPa (18 psi) to the fuel conditioning system is required. Use a Motorcraft E7T2-9C407-BA fuel pump. The fuel conditioning system is part of the golden stand supplied by Test Engineering Inc.

7. Reagents and Materials

NOTE 6—Use 12 L and 2600 g ($\sim 3000 \text{ ml}$) of the non-reference test oil sample to perform the 200 h Valve-train Wear test.

7.1 *Coolant for Engine and Rocker Arm Cover*—The engine coolant shall have been GM6277M approved (Dexcool (trademark)) mixed 30/70 with demineralized or distilled water.

7.2 *Fuel*—Use Haltermann KA24E Green test fuel for this test method as shown in [Annex AX](#). (**Warning**—Flammable. Health hazard.) It is dyed green to preclude unintentional contamination with other test fuels. Use approximately 750 L of fuel for each test (24000 cycles). This fuel has a hydrogen-to-carbon ratio of 1.80 to 1.

7.2.1 *Fuel Approval Requirements*—The fuel is blended to a sulfur content of $130 \pm 10 \text{ ppm}$ and the fuel supplier's requirements. Base the fuel batch acceptance upon the physical and chemical specifications given in [Annex AX](#). Engine validation tests are not necessary for fuel batch acceptance.

7.2.2 *Fuel Analysis*—Monitor the test fuel using good laboratory practices. Analyze each fuel shipment to determine the value of each parameter for fuel sulfur as described in Test Method [D2622](#), existent gum as described in Test Method [D381](#), RVP as described in Test Method [D323](#), and API Gravity as described in Test Method [D287](#). Compare the results to the original values supplied by the fuel supplier. The analytical results shall be within the tolerances shown in parentheses beside



each parameter. This provides a method to determine if the fuel batch is contaminated or has aged prematurely. If any analytical result falls outside the tolerances, the laboratory shall contact the fuel supplier for problem resolution.

7.2.2.1 *Fuel Deterioration*—Analyze the fuel semiannually to ensure the fuel has not deteriorated excessively or been contaminated in storage.

7.2.2.2 Analyze the fuels using Test Methods D2622, D287, D323, D381, and D525.

7.2.3 *Fuel Shipment and Storage*—Ship the fuel in containers with the minimum allowable venting as dictated by all safety and environmental regulations, especially when shipment times are anticipated to be longer than one week. Store the fuel in accordance with all applicable safety and environmental regulations. If the run tank has more than one batch of fuel, document the most recent batch in the test report.

7.3 *Lubricating Oils:*

7.3.1 *Break-in Lubricating Oil*—An engine break-in procedure (see 11.1.3) is immediately conducted following the replacement of new, major engine components (that is, engine short-block, or cylinder head, or both). Use the proper reference oil, REO 1006-2, from the TMC for the break-in procedure. Use 3 L of this reference oil for each break-in procedure.

7.3.3 *Short-block Assembly Lubricant*—For engine short-block inspection and reassemble, use EF-411 oil as the assembly lubricant.

7.4 *Miscellaneous Materials:*

7.4.1 *Solvents and Cleansers*—No substitutions for 7.4.1.1 – 7.4.1.3 are allowed. Use adequate safety provisions with all solvents and cleaners.

7.4.1.1 *Degreasing Solvent*—Use only mineral spirits meeting the requirements of Specification D235, Type II, Class C for Aromatic Content ((0 to 2) vol %), Flash Point (61 °C, min) and Color (not darker than +25 on Saybolt Scale or 25 on Pt-Co Scale). (**Warning**—Combustible. Health hazard.) Obtain a Certificate of Analysis for each batch of solvent from the supplier.

7.4.1.2 *Pentane*—(**Warning**—Flammable. Health hazard.) Available from petroleum solvent suppliers.

7.4.1.3 *Cylinder Block and RAC Cleaning Detergent*—Tri-sodium phosphate and any commercial coolant cleanser. (**Warning**—Caustic. Health hazard.)

7.4.2 *Sealing Compounds*—Use a silicone based gasketing compound during engine assembly (for example, oil pan). Use only the silicone gasket shown in Annex AX.

8. Oil Blend Sampling Requirements

8.1 *Sample Selection and Inspection*—The non-reference oil sample shall be uncontaminated and representative of the lubricant formulation being evaluated.

NOTE 7—If the test is registered using the American Chemistry Council²⁶⁵ protocols, the assigned oil container formulation number shall match the registration form.

8.2 *Non-reference Oil Sample Quantity*—Use a minimum of 15 L of new oil to complete the Sequence IVB test, including the oil flushes. Normally the supplier provides a 19 L new oil sample to allow for inadvertent losses.

8.3 *Reference Oil Sample Quantity*—The TMC provides a 19 L reference oil sample for each stand calibration test.

9. Preparation of Apparatus

NOTE 4—This section details those recurring preparations necessary for test operation. This section assumes the engine test stand facilities and other hardware described in Section 6 are in place.

9.1 *Test Stand Preparations:*

9.1.1 *Instrumentation Calibration*—Calibrate all sensors and indicators before or during the test for the type instrumentation used. See Section 10 for the calibration requirements.

9.1.2 *External Oil System Cleaning*—Use clean mineral spirits followed by forced-air drying to clean the external oil system (see x.x.x).

9.1.3 *Air Cleaner Filter*—Replace the air cleaner filter element when an engine is replaced, or more frequently if intake air pressure is insufficient.

9.1.4 *Draining Exhaust Piping*—Prior to the start of each test, drain the low point of the exhaust piping to eliminate water accumulation. Drain water during a test if exhaust pressure control becomes unstable.

9.1.5 *External Hose Replacement*—Inspect all external hoses used on the test stand and replace any hoses that have become

⁶ American Chemistry Council, 1300 Wilson Boulevard, Arlington, VA 22209.



unserviceable. Check for internal wall separations that could cause flow restrictions. Inspect and replace the external oil system hoses every **as needed**.

9.1.6 *Stand Ancillary Equipment*—Service the dynamometer and driveline components, as required. The dynamometer torque measurement shall be accurate (no unaccounted forces from hoses, load cell temperature gradients, or trunnion bearing hysteresis).

9.2 *General Engine Assembly Preparations*—Refer to the Sequence IVB Engine Assembly Manual.

10. Data Acquisition, Reference Oil Application, and Equipment Calibration and Maintenance

10.1 Data Acquisition:

10.1.1 Computer *Data Acquisition*—The test stand should log operational data using a computer data acquisition system with sensor configurations process is described in 10.1.2 – 10.1.4.

10.1.2 Frequency of *Logged Test Cycle Data*—Log the test cycle data at a sampling rate of 1-Hz.

10.1.3 *Signal Conditioning*—Do not exceed the controlled operational parameters for system time response as shown in **Table 1**. The system time response includes the total system of sensor, transducer, analog signal attenuation, and computer digital filtering. Use single-pole type filters for attenuation. For temperature sensors only grounded thermocouples are acceptable.

10.1.3.1 *Isolated Inputs*—Use signal-conditioning modules to provide isolated inputs to the digital computer.

10.2 Reference Oil Application:

NOTE 8—10.2.6 and 10.2.7 and Annex A1 - 4 describe the involvement of the TMC in respect to calibration procedures and acceptance criteria for a testing laboratory and a test stand, and the issuance of Information Letters and memoranda affecting the test method.

10.2.1 *Testing of Reference Oils*—Periodically conduct tests on reference oils according to the following:

10.2.1.1 Conduct reference oil tests on each calibrated test stand within a laboratory according to TMC guidelines.

10.2.1.2 Obtain reference oils directly from the TMC. These oils are formulated or selected to represent specific chemical types or performance levels, or both. They are usually supplied directly to a testing laboratory under code numbers to ensure that the laboratory is not influenced by prior knowledge of acceptable results in assessing the test results. The TMC determines which specific reference oil the laboratory shall test.

10.2.1.3 Unless specifically authorized by the TMC, do not analyze reference oils, either physically or chemically. Identification of reference oils by such analyses could undermine the confidentiality required to operate an effective reference oil system. Therefore, reference oils are supplied with the explicit understanding that they will not be subjected to analyses other than those specified in this procedure, unless specifically authorized by the TMC. If so authorized, prepare a written statement of the circumstances involved, the name of the person authorizing the analysis, and the data obtained; furnish copies of this statement to the TMC.

10.2.2 *Reference Oil Test Frequency*—Conduct reference oil tests according to the following frequency requirements:

10.2.2.1 For a given, calibrated test stand, conduct an acceptable reference oil test after no more than **XX** test starts have been conducted, or **after TBD** have elapsed, whichever occurs first.

10.2.2.2 After starting a laboratory reference oil test, non-reference oil tests may be started on any other calibrated test stand.

10.2.2.3 Reference oil test frequency may be adjusted due to the following reasons:

10.2.3 *Procedural Deviations*—On occasions when a laboratory becomes aware of a significant deviation from the test method, such as might arise during an in-house review or a TMC inspection, the laboratory and the TMC shall agree on an appropriate course of action to remedy the deviation. This action may include the shortening of existing reference oil calibration periods.

10.2.4 *Parts and Fuel Shortages*—Under special circumstances, such as industry-wide parts or fuel shortages, the Surveillance Panel may direct the TMC to extend the time intervals between reference oil tests. These extensions shall not exceed one regular calibration period.

10.2.5 *Reference Oil Test Data Flow*—To ensure continuous severity and precision monitoring, calibration tests are conducted periodically throughout the year. There may be occasions when laboratories conduct a large portion of calibration tests in a short period of time. This could result in an unacceptably large time frame when very few calibration tests are conducted. The TMC can shorten or extend calibration periods as needed to provide a consistent flow of reference oil test data. Adjustments to calibration periods are made such that laboratories incur no net loss (or gain) in calibration status.

10.2.6 *Special Use of the Reference Oil Calibration System*—The Surveillance Panel has the option to use the reference oil system to evaluate changes that have potential impact on test severity and precision. This option is only taken when a program of donated tests is not feasible. The Surveillance Panel and the TMC shall develop a detailed plan for the test program. This



plan requires all reference oil tests in the program to be completed as close to the same time as possible, so that no laboratory/stand calibration is left in an excessively long pending status. To maintain the integrity of the reference oil monitoring system, each reference oil test is conducted to be interpretable for stand calibration. To facilitate the required test scheduling, the Surveillance Panel may direct the TMC to lengthen and shorten reference oil calibration periods within laboratories such that the laboratories incur no net loss (or gain) in calibration status.

10.2.7 *Donated Reference Oil Test Programs*—The Surveillance Panel is charged with maintaining effective reference oil test severity and precision monitoring. During times of new parts introductions, new or re-blended reference oil additions, and procedural revisions, it may be necessary to evaluate the possible effects on severity and precision levels. The Surveillance Panel may choose to conduct a program of donated reference oil tests in those laboratories participating in the monitoring system, to quantify the effect of a change on severity and precision. Typically, the Surveillance Panel requests its panel members to volunteer enough reference oil test results to create a robust data set. Broad laboratory participation is needed to provide a representative sampling of the industry. To ensure the quality of the data obtained, donated tests are conducted on calibrated test stands. The Surveillance Panel shall arrange an appropriate number of donated tests and ensure completion of the test program in a timely manner.

10.2.8 *Reporting of Reference Oil Test Results*—Report the results of all reference oil tests to the TMC according to the following directives:

10.2.8.1 Transmit results to the TMC within five days of completing post-test measurements by way of electronic data transfer protocol as outlined in the Data Communication Committee, Electronic Test Report Transmission Model (ETRTM). The ETRTM can be obtained from the TMC.

10.2.8.2 If the test was conducted during a time extension permitted by the TMC, so indicate in the Comments section of the test report.

10.2.8.3 For an acceptable reference oil test, conducted following an unacceptable reference oil test, provide sufficient information in the Comments section of the test report to indicate how the problem was identified and corrected, insofar as possible, and how it was related to non-reference oil tests conducted during the period that the problem was being solved.

10.2.9 *Evaluation of Reference Oil Test Results*—The TMC evaluates the reference-oil test results for both operational validity and statistical acceptability. The TMC may consult with the test laboratory in case of difficulty, as follows:

10.2.9.1 Immediately upon receipt of the reference-oil test results from the test laboratory, the TMC evaluates the laboratories decision on operational validity. For operationally valid tests, the TMC then evaluates the pass/fail parameters according to the Sequence IVB Lubricant Test Monitoring System (TBD). If the test is judged acceptable, the reference oil code is disclosed by the TMC to the test laboratory. The TMC conveys to the test laboratory its preliminary findings based on the limited information available to them.

10.2.9.2 Subsequently, upon receipt of the information detailed in **XX** the TMC reviews all reference-oil test results and reports to determine final test acceptability.

10.2.9.3 In the event the reference oil test is unacceptable, the test laboratory shall provide an explanation of the problem relating to the failure. If the problem is not obvious, all test-related equipment shall be re-checked. Following this re-check, the TMC assigns another reference oil for testing by the laboratory.

10.2.9.4 The TMC decides, with consultation as needed with industry experts (testing laboratories, members of the ASTM Technical Guidance Committee and of the Surveillance Panel, and so forth), whether the reason for any failure of a reference oil test is a false alarm, testing stand, testing laboratory, or industry-related problem. The Sequence IVB Surveillance Panel shall adjudicate all industry problems.

10.2.10 *Status of Non-Reference Oil Tests Relative to Reference Oil Tests*—Non-reference oil tests may proceed within a given laboratory during reference oil testing based upon the following:

10.2.10.1 During the time of conducting a reference oil test on one test stand, non-reference oil tests may be conducted on other previously calibrated stands. If the reference oil test is acceptable to the TMC, the non-reference oil tests shall be considered to have been run in a satisfactorily calibrated laboratory.

10.2.10.2 If a reference oil test is unacceptable, and it is determined that the problem is isolated to an individual test stand, consider other test stands to remain calibrated, and testing of non-reference oils may proceed on those other stands.

10.2.10.3 If a reference oil test is unacceptable, and it is determined that the problem is laboratory related, non-reference tests running during the problem period shall be considered invalid unless there is specific evidence to the contrary for each test.

10.2.11 *Status of Test Stands Used for Non-Standard Tests*—If a non-standard test is conducted on a previously calibrated test stand, conduct a reference oil test on that stand to demonstrate that it continues to be calibrated, prior to running standard tests.

10.3 *Equipment Calibration:*

10.3.1 *Instrumentation Calibration*—Perform a thorough recalibration adjustment of all instrumentation and transducers,



including computer channels, according to the requirements that follow. Perform additional calibration checks whenever operational data indicates an abnormality. Standards used for instrumentation calibration shall be traceable to that country's specific national standards organization. The accuracy of the standard shall be a minimum of four times better than the accuracy of the test stand instrumentation.

10.3.2 Dynamometer *Torque Measurement*—Scale the final readout of engine torque (N·m). Calibrate the force measurement and readout system with deadweights. Coolant flow through the dynamometer, reaction forces due to coolant plumbing, and brinnelled trunnion bearings of the dynamometer may affect calibration by temperature excursions of the dynamometer electronic force transducer. When calibrating, ensure the dynamometer coolant flow indicator is in the green and that the load cell temperature has been stabilized at $45^{\circ}\text{C} \pm 1^{\circ}\text{C}$ for a minimum of one hour. Perform this calibration prior to every test start.

10.3.3 Instrument Calibration—Document all instrument calibrations. Retain all calibration documentation for a minimum of 3 years.

10.3.3 Upon initial stand installation and every 6 months thereafter perform a full instrumentation calibration according to

TABLE 4 Parameters to be Calibrated Every 6 Months

Items
Temperatures
Intake Air Temperature, °C
Engine Oil Gallery Temperature, °C
Engine Oil Sump Temperature, °C
Coolant Temperature into Engine, °C
Coolant Temperature Out of Engine, °C
Fuel Rail Temperature, °C
Exhaust Gas Temperature, °C
Valve Cover Coolant In Temperature, °C
Valve Cover Coolant Out Temperature, °C
Test Cell Air Temperature, °C
Blow-by Gas Temperature, °C
Blow-by Coolant Temperature, °C
Pressures
Crankcase Gas Pressure, kPa
Oil Gallery Pressure, kPa
Fuel Rail Pressure, kPa
Exhaust Pressure, kPa (absolute)
Intake Air Pressure, kPa
Intake Manifold Pressure, kPa (absolute)
Barometric Pressure, kPa (absolute)
Flows
Air Fuel Ratio, afr
Blowby Flow Rate, sl/min
Fuel Flow Rate, kg/h



Engine Coolant Flow Rate, L/min

Valve Cover Coolant Flow Rate, L/min

General

Intake Air Humidity, grains/kg

Engine Speed, r/min

Engine Torque (N-m)

10.3.4 Humidity of Induction Air Calibration:

10.3.4.1 Calibrate the primary laboratory measurement system at each test stand every 6 months using a hygrometer with a minimum dew point accuracy of ± 0.55 °C at 16 °C. Locate the sample tap on the air supply line to the engine, between the main duct and 1000 mm upstream of the intake air cleaner. The calibration consists of a series of paired humidity measurements comparing the laboratory system with the calibration hygrometer. The comparison period lasts from 20 min to 2 h with measurements taken at intervals of (1 to 6) min, for a total of 20 paired measurements. The measurement interval shall be appropriate for the time constant of the humidity measurement instruments.

10.3.4.2 Verify that the flow rate is within the equipment manufacturer’s specification and that the sample lines are non-hygroscopic. Correct dew point hygrometer measurements to standard conditions (101.12 kPa) using the appropriate equation. Compute the difference between each pair of readings and calculate the mean and standard deviation of the twenty-paired readings. The absolute value of the mean difference shall not exceed 1.43 g/kg, and the standard deviation shall not be greater than 0.714 g/kg. If these conditions are not met, investigate the cause, make repairs, and recalibrate. Maintain calibration records for 2 years.

10.3.5 Profilmeter Calibration—Follow the manufacturer’s instruction for calibration and verification checks of the profilmeter. Calibrate the profilmeter at least annually.

10.3.6 Keyence Measurement Device —Confirm the calibration of the Keyence measurement device with the reference standard before every use.

Comment [k10]: How is this documented
Comment [k11]: Checked during 20170817 call

11. Procedure

NOTE 9—When installing a new engine and cylinder head or both, conduct break-in and aging procedures, see 11.2.6 and 11.2.7, before running official 200 h tests. After completing the break-in, install the official test valve-train parts as shown in the Sequence IVB Assembly Manual. Then conduct the pre-test procedure and four fired oil-flushes as shown in 11.3.1. After performing the four-fired oil-flushes, conduct the 200 h test as shown in 11.3.2.

11.1 Engine Start Procedure: Whenever an engine is started this procedure should be followed.

11.1.1 Before starting the engine, check DyneSystems PAU status, and if necessary, perform reset procedure (see Figure 1).

11.1.2 When starting the engine, set DyneSystems PAU throttle position to a set percent to achieve > 500 rpm (typical range is 5 – 15%).

11.1.3 When starting the engine, set DyneSystems PAU dynamometer excitation to 0%

11.1.4 Energize the starter motor for 7 seconds or until engine speed is greater than 500 rpm, whichever comes first. Then, turn off the starter motor. As soon as the engine speed is greater than 500 rpm proceed to target conditions.



Fig. 1 DyneSystems PAU

11.2 Pre-test Procedure:

11.2.1 Pre-test stand cleaning—Clean all pressure traps, the external oil system and the external blow-by system prior to starting all tests.

11.2.1.1 Remove, spray clean with degreasing solvent, and air dry the exhaust backpressure and crankcase pressure filters. Re-install the filters and inspect and replace the O-rings (Norgreen part 4380-700) as needed.

Comment [k12]: TEI part

11.2.1.2 Disconnect the external oil supply and oil return lines from the remote oil filter housing adapter that is mounted on the engine (refer to Fig. 2).

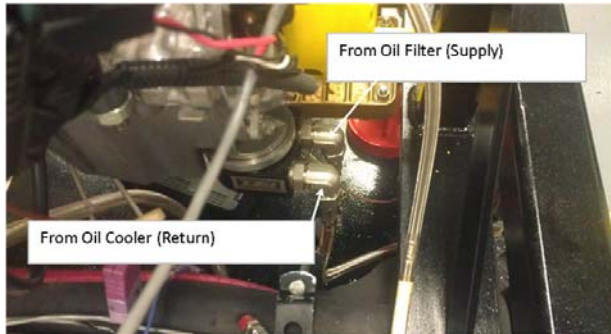

Fig. 2 Remote Oil Filter Housing Adapter

11.2.1.3 Connect the external oil supply and external oil return lines to a portable oil cleaning flush cart of minimum 1 gal capacity that is equipped with a circulation pump with a flow capacity of at least 1 gpm. Charge the flush cart with solvent and energize the flush cart pump. Allow the solvent to circulate for 5 min. De-energize flush cart, open both heat exchanger drain valves and allow the external oil system to drain. Close drain valves, re-charge the flush cart, re-energize the flush cart and allow solvent to recirculate for approximately 1 h.

11.2.1.4 After solvent has circulated for at least one hour, de-energize the flush cart pump and open both heat exchanger drain valves and allow the external oil system to drain.

11.2.1.5 Disconnect the external oil supply and external oil return lines from the flush cart and connect the external oil system to a clean and dry compressed air supply at 15 psi to 30 psi. Allow the air to flow through the system for at least 15 min to dry the system.

11.2.1.6 Disconnect the supply and return lines from the compressed air source and connect the external oil supply and external return lines back to the remote oil filter housing adapter that is mounted on the engine. Close the heat exchanger drain valves.

11.2.1.7 Remove the Oberg oil filter element (B in Fig. 2) for cleaning. Clear any debris retained in the Oberg oil filter element with degreasing solvent and air dry. Re-install the Oberg oil filter element in the Oberg filter housing (A in Fig. 3) and secure the four retaining bolts. Part number and supplier info is available in Appendix A-1.

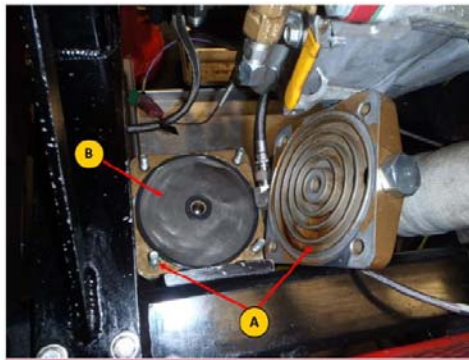

Fig. 3 Disassembled Oberg Filter Housing (A) with filter element (B)



11.1.1.8 Disconnect the oil pressure sense line between the engine and oil sample valve. Rinse this line using clean degreasing solvent and air dry.

11.1.1.9 Disconnect the oil pressure sense line between the oil sample valve and the oil pressure transducer. Rinse this line using clean degreasing solvent and air dry.

11.1.1.10 Open the oil sample valve and allow any trapped oil to drain. Then close the valve and reconnect both oil pressure and sample lines to their respective locations.

11.2 Oil pan flush—Flush the oil pan with EF-411 oil supplied by an external pump prior to all tests.

11.2.1 Pour 1 gallon of new EF-411 into a clean oil flush apparatus.

11.2.2 The apparatus must include a pump with at least 1 gpm of flow, an oil filter, and if pipe fittings are used, they must be black or stainless. A NAPA 1-8429 oil filter adapter, and unused Motorcraft FL 1A oil filter, and GP-201-12L pump are suggested.

11.2.2.3 Connect the apparatus supply to the #8 AN fitting on the side of the modified Sequence IVB oil pan and the return to the rear oil pan drain plug.

11.2.2.4 Run the pump and circulate the EF-411 through the oil pan for 10 min.

11.2.2.5 Turn off the pump, remove the apparatus, and allow the EF-411 to drain for 5 min.

11.2.2.6 Re-install a stainless-steel cap on the #8 fitting on the side of the oil pan and re-install the oil pan drain plug.

11.2.3 Blow-by system cleaning—Clean the blow-by heat exchanger, plumbing and oil separator before every test.

11.2.3.1 Remove the blow-by heat exchanger, plumbing and oil separator from the test stand and remove the insulation from the plumbing and oil separator

11.2.3.2 Disassemble the heat exchanger and oil separator for cleaning.

11.2.3.3 Spray clean the inside of separator and gas side of the heat exchanger with degreasing solvent and air dry.

11.2.3.4 Remove all the short Tygon hose sections between the valve cover and external blow-by system heat exchanger and replace as needed.

11.2.3.5 Spray clean the inside of all plumbing fittings and any Tygon hose sections that will be reused.

11.2.3.6 Insulate the oil separator and blow-by plumbing, and reinstall on the test stand, in accordance with the Oil Separator and Blow-by Plumbing Insulation Procedure, Annex A8.

11.2.3.7 Reconnect the external blow-by system to the valve cover and blow-by gas filter.

11.2.4 Engine coolant fill procedure—Charge the engine coolant, rocker cover coolant, and blow-by heat exchanger coolant tanks with coolant that conforms to section 7.1 prior to the start of all tests.

11.2.4.1 Fill the engine coolant system with approximately 26 L of coolant so that coolant is visible within 50 mm of the top of tank level indicator.

11.2.4.2 Fill the rocker cover coolant system with approximately 20 L of coolant so that coolant is visible within 50 mm of the top of tank level indicator.

11.2.4.3 Fill the blow-by coolant system so that coolant is visible within 50 mm of the top of tank level indicator.

11.2.4.4 Pressurize the coolant system to 70 kPa ± 10 kPa.

11.2.4.5 Minimize air bubbles in the engine, valve cover, and blow-by coolant systems.

11.2.5 Dynamometer load cell calibration—Calibrate the load cell in accordance with the specifications in Table 7 below. A Dyne Systems Traceable Weight Set DS-A266 is recommended.

Comment [k13]: Part number?

Comment [k14]: Added 8/29/17.

TABLE 7 Dynamometer Load Cell Calibration Reference

<u>Calibration Point</u>	<u>Reference Calibration Target Mass, kg</u>	<u>Resulting Reference Torque, N-m</u>	<u>Maximum Error</u>
<u>Zero</u>	<u>2.535</u>	<u>9.94</u>	<u>0.5%</u>
<u>Mid-range</u>	<u>7.130</u>	<u>27.97</u>	<u>0.5%</u>
<u>Span</u>	<u>11.335</u>	<u>44.47</u>	<u>0.5%</u>

11.2.5.1 Apply the calibration weights onto the dyno load arm that will result in the load cell being in tension. The calibration reference values used must be within ±0.2 kg of the values in Table 7.

11.2.5.2 Ensure that dynamometer load cell temperature has stabilized at 45 °C ± 1 °C before beginning calibration.

11.2.6 Engine break-in procedure—Conduct the break-in procedure and aging procedures prior to lubricant evaluation testing when installing a new engine block or new cylinder head assembly on a test stand. The break-in allows for monitoring test stand and engine performance. Use the engine block assembly for XX tests and the head for XX tests. Follow the break in conditions in Table A.1. Use the following break-in steps:



11.2.6.1 Install break-in parts according to Assembly Manual Section 2. Install a stock unmodified Toyota intake camshaft, stock valve springs, and unmeasured bucket lifters for break-in.

11.2.6.2 Install the stock black plastic valve train cover (item D in Fig. 3 below) and stock crankcase ventilation setup.

11.2.6.3 Refer to Fig. 4, connect the PCV valve (A) in the valve cover to the intake manifold port (C) with the stock 19 mm ventilation hose (B).

11.2.6.4 Refer to Fig. 5, connect the valve cover port (A) to the intake air filter housing port (B) with a 15.8 mm diameter Tygon hose (C).

11.2.6.5 Refer to Fig. 6, connect the braided stainless-steel hose (B) from the crankcase pressure transducer to the quick disconnect (A) on the modified oil fill cap.

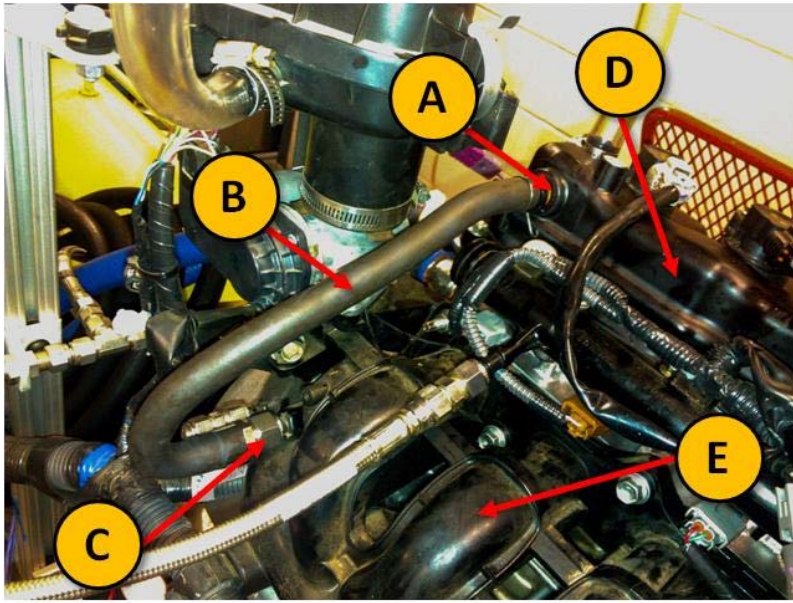

Fig. 4 Routing of crankcase gases. (A) stock PCV valve, (B) 19 mm diameter hose, (C) hose adapter to intake manifold, (D) stock valve train cover, (E) intake manifold. The 19 mm diameter hose is the OEM provided crankcase ventilation hose which is installed on new engines.

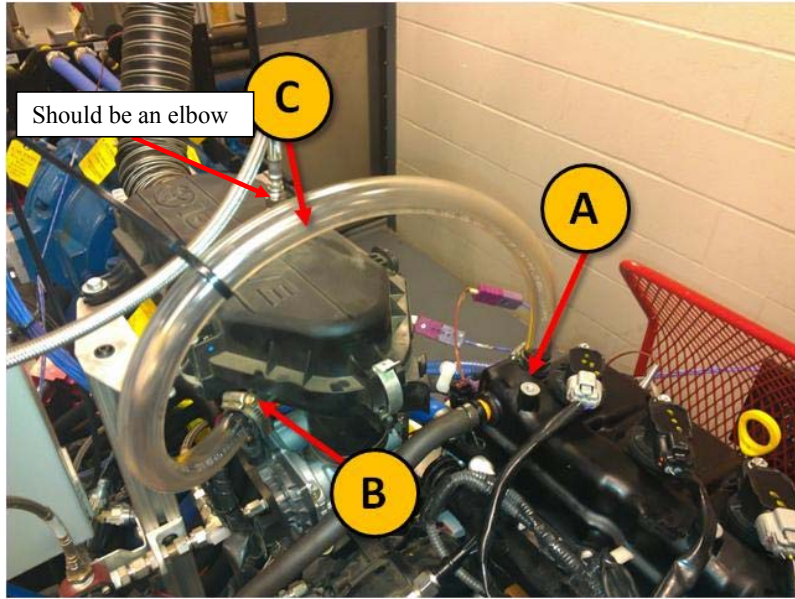

Fig. 5 Routing of fresh air. (A) Port to valve train cover, (B) port from intake air filter housing, (C) 15 mm diameter Tygon hose

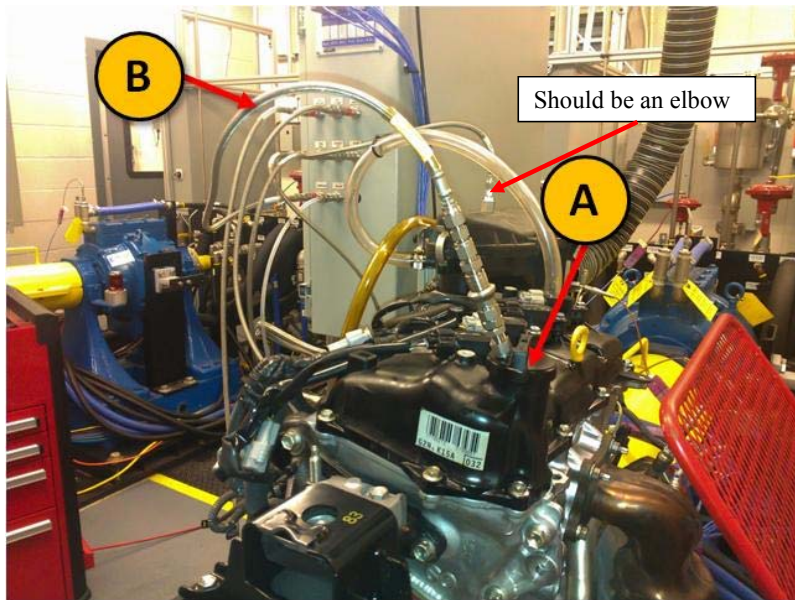

Fig. 6 Crankcase pressure measurement point. (A) Oil fill cap modified with 5 mm diameter quick disconnect, (B) 8 mm diameter steel-braided hose to pressure transducer



11.2.6.6 Perform all pre-test procedures, sections 11.1.1 to 11.1.5.
 11.2.6.7 Fill the engine with 3000 ml of ASTM REO 1006-2 as break-in oil.
 11.2.6.8 Start the engine and begin the break-in schedule provided in Table A.1. Engine load and speed is ramped and stabilized within the first 45 s and 60 s respectively.
 11.2.6.9 Control the parameters specified in Table 8 below to constant set-points over the entire course of the break-in, aging, and oil sampling.

TABLE 8 Break-in, Aging, and Oil Sampling Constant Set-points

Parameter	Set-point
Fuel rail temperature, °C	24 ± 3
Fuel rail pressure, kPa	335 ± 10
Coolant flow rate, L/min	80 ± 1
Coolant Pressure, kPa	70 ± 10
Exhaust backpressure, kPaA	103.5 ± 1.0?
Intake air pressure, kPaA	0.25 ± 0.1
Intake air temperature, °C	32 ± 2
Load cell temperature, °C	45 ± 2
Intake air humidity, g/kg	11.5 ± 0.5

Comment [k15]: Need to identify alternate

Comment [k16]: Action item for all labs to donate prove-out engine break-in data.

11.2.6.10 Record the values of all the controlled parameters listed in Table 8 and Table A.1 during break-in steps 5 and 8.
 11.2.6.11 Following the completion of engine break-in, establish the oil sampling conditions listed in Table 9. Engine load and speed is ramped and stabilized within the first 45 s and 60 s respectively.

TABLE 9 Break-in and Aging Oil Sampling Conditions

Engine Speed, rpm	Engine Load, Nm	Gallery Oil Temperature, °C	Coolant Out Temperature, °C
1000	10.0	80 Max	80 Max

Comment [k17]: These temperatures are not possible as Bill pointed out.

Comment [k18]: Exxon believes they require 10 ml but are looking into it.

11.2.6.12 Once the conditions have stabilized, take a 240 ml purge sample followed by a 3-10 ml oil sample and return the 240 ml purge sample to the oil fill cap. This step should be completed within 10 min of the oil sampling conditions being achieved. If that is not possible, the engine should be shutdown.

11.2.6.13 Turn off the engine and allow to rest for 10 min prior to checking the oil level with the OHT IVB dipstick (part # IVB022-3) that is located on the side of the oil pan. The scribe mark on the OHT dipstick should align with the mark on the dipstick tube when it is inserted. Ensure that no air is applied to the engine while checking the oil level.

11.2.7 Engine aging procedure— Engine oil aging ensures that the silicone sealant within the engine has been pacified. It should be done immediately following break-in using the same oil charge when a new engine or head is installed on a test stand.

11.2.7.1 Start the engine and run the aging conditions in Table 10 below and Table 8 for 5 h. Engine load and speed is ramped and stabilized within the first 45 s and 60 s respectively.

TABLE 10 Engine Aging Conditions

Engine Speed, rpm	Engine Load, Nm	Gallery Oil Temperature, °C	Coolant Out Temperature, °C
3000	50.0	80	80

Comment [k19]: Change to 88 or slightly higher like during test (90?)

Comment [k20]: Changed during 8/22/17 call

Comment [k21]: Exxon believes they require 10 ml but are looking into it.

11.2.7.2 After 5 h of aging have been completed, establish the oil sampling conditions listed in Table 9. Engine load and speed is ramped and stabilized within the first 45 s and 60 s respectively.

11.2.7.3 Once the conditions have stabilized, take a 240 ml purge sample followed by a 3-10 ml oil sample and return the 240 ml purge sample to the oil fill cap. This step should be completed within 10 min of the oil sampling conditions being achieved. If that is not possible, the engine should be shutdown.

11.2.7.4 Turn off the engine and allow to rest for 10 min prior to checking the oil level with the OHT IVB dipstick (part # IVB022-3) that is located on the side of the oil pan. The scribe mark on the OHT dipstick should align with the mark on the dipstick tube when it is inserted. Ensure that no air is applied to the engine while checking the oil level.

11.2.7.5 Conduct section 11.1.7.1-11.1.7.4 ten total times for a total of 50 hours of aging.

11.2.7.6 Examine the results of the ASTM D5185 for high wear anomalies using Fe, Cu, and Al and to ensure the Si levels have plateaued. Also examine values of K as an indicator of coolant leaks. K values exceeding 15 ppm are suspicious and the engine should be evaluated for an internal coolant leak. If an internal coolant leak is confirmed, make repairs and repeat the run-in and aging procedure. An example of the plateau of Si during is given in figure 7 below.

11.2.7.7 Drain the oil charge after aging is completed.

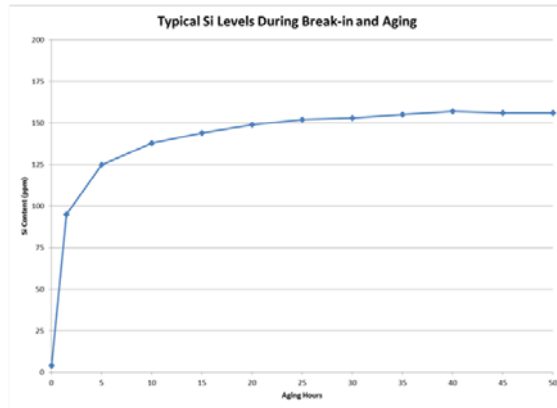

Fig. 7 Example of Si Plateau during break-in and aging

11.2.7 *Engine silicone pacification*—Conduct the engine silicone pacification procedure when a used engine that has been reassembled is installed on a test stand. Removal and re-installation of an oil pan or front cover is considered reassembly.

11.2.7.1 Perform all pre-test procedures, sections 11.1.1 to 11.1.3.

11.2.7.2 Fill the engine with 3.0 L of ASTM REO 1006-2 as break-in oil.

11.2.7.3 Perform engine oil aging, sections 11.1.7.

11.3 *Test Procedure:*

11.3.1 *Engine flushes*—Conduct four fired flushes with 3000 ml of test evaluation oil at the conditions listed in Table 11. Engine load and speed is ramped and stabilized within the first 60 s and 90 s respectively

Comment [k22]: Need to identify alternate

Table 11 Engine Oil Flush Operating Parameters

Parameter	Setpoint
Engine Speed	1500 rpm
Torque	10 N·m
Engine Coolant Out Temperature	80 °C
Engine Oil Gallery Temperature	80 °C
Exhaust Back Pressure	103.5 kPa _g
Intake Air Pressure	0.25 kPa _g
Intake Air Temperature	32 °C
Fuel Temperature	24 °C
Rocker Cover Outlet Temperature	20 °C
Coolant Flow Rate (Engine)	80 L/min
Coolant Flow Rate (Rocker Arm Cover)	120 L/min
Load Cell Temperature	45 °C
Blowby Gas Temperature	29 °C
Coolant Temperature Heater	Heater OFF

Comment [k23]: 8/29/17 agreed

11.3.1.1 Conduct the 1st engine flush by filling the engine with 3000 ml and operating at the Table 11 conditions for 6 min.

11.3.1.2 After the first flush, turn the engine off following the non-emergency shutdown procedure (step 11.3.4.1) and conduct a compression and leak-down test and record these values. Engine oil is required for the leak-down test

11.3.1.3 Drain the flush oil from the oil pan drain plug and the two-external oil system heat exchanger drain valves for 30 min. Retain an oil sample for analysis.

11.3.1.4 Conduct the 2nd flush by filling the engine with 3000 ml and operating at the Table 11 conditions for 38 min.

11.3.1.5 Drain the flush oil from the oil pan drain plug and the two-external oil system heat exchanger drain valves for 30 min. Retain an oil sample for analysis.

11.3.1.6 Repeat steps 11.2.1.4 and 11.2.1.5 for the 3rd and 4th flush.

11.3.2 *Test Operation*—Conduct a 200 h test consisting of 24000 thirty second 4-stage cycles under the conditions specified by Table 4, Table 5, and Table 12.

Comment [k24]: From Section E but the non-emergency shutdown is probably too long coming off a 6 minute step



TABLE 12 Summary of Sequence IVB Test Operating Conditions

Parameter	Units	Ramp to Stage 1	Stage 1	Ramp to Stage 2	Stage 2
Duration	s	8	Z	8	Z
Engine Speed	Rpm	4300 to 800	800	800 to 4300	4300
Engine Torque	N-m	25 ± 1.5	25 ± 1.5	25 ± 1.5	25 ± 1.5
Coolant Out Temperature	°C	52 ± TBD	52 ± TBD	52 ± TBD	52 ± TBD
Coolant Flow (Engine)	L/min	80 ± 0.4	80 ± 0.4	80 ± 0.4	80 ± 0.4
Coolant Flow (RAC)	L/min	120 ± 0.75	120 ± 0.75	120 ± 0.75	120 ± 0.75
Oil Gallery Temperature	°C	54 ± 4	54 ± 4	54 ± 4	54 ± 4
RAC Coolant Out Temperature	°C	20 ± 0.75	20 ± 0.75	20 ± 0.75	20 ± 0.75
Fuel Rail Temperature	°C	24 ± 0.5	24 ± 0.5	24 ± 0.5	24 ± 0.5
Load Cell Temperature	°C	45 ± 4	45 ± 4	45 ± 4	45 ± 4
Intake Air Temperature	°C	32 ± 0.75	32 ± 0.75	32 ± 0.75	32 ± 0.75
Blowby Gas Temperature	°C	29 ± 0.5	29 ± 0.5	29 ± 0.5	29 ± 0.5
Intake Air Pressure	kPa	0.25 ± 0.25	0.25 ± 0.25	0.25 ± 0.25	0.25 ± 0.25
Intake Air Humidity	g/kg	11.5 ± 0.5	11.5 ± 0.5	11.5 ± 0.5	11.5 ± 0.5
Exhaust Pressure	kPaA	-	-	-	104.5 ± 3
Engine Coolant Pressure	kPa	70 ± 10	70 ± 10	70 ± 10	70 ± 10
Fuel Rail Pressure	kPa	335 ± 10	335 ± 10	335 ± 10	335 ± 10
Air-to-Fuel Ratio (Not Controlled)	:1	Record	14.5 ± 0.5	Record	14.5 ± 0.5

Comment [k25]: Was ±5 corrected to 4 on 8/30/17

11.3.2.1 Perform all pre-test procedures in section 11.1.

11.3.2.2 Remove the external oil system, 28 µm Oberg filter screen (part # OHT6A-013-2), clean with degreasing solvent, and air dry.

11.3.2.3 Weight out a 2600 g test charge and fill the engine.

11.3.2.4 Operate the engine at stage 1 idle conditions for 10 min then shutdown the engine and wait 10 min before measuring the oil level using the modified Sequence IVB dipstick that inserted into the side of the oil pan. Engine load and speed is ramped and stabilized within the first 45 s and 60 s respectively.

11.3.2.5 Start the engine with stage 1 operating targets and run for at least 3 min and until reaching a coolant out temperature of at least 50°C and an oil gallery temperature of at least 50 °C. If these targets are still not achieved after 10 minutes, proceed to test. Engine load and speed is ramped and stabilized within the first 45 s and 60 s respectively when starting the engine.

Comment [k26]: Changed TCO to 50 and TLG to 50

11.3.3 Begin first cycle of test operations.

11.3.3.1 Intermediate oil samples are required at 25, 50, 75, 100, 125, 150, 175, and 200 test hours. 60 ml oil samples are taken at every 25 h interval.

Comment [k27]: Exxon believes they need 80 ml but are looking into it.

11.3.3.2 The 0 h sample should be analyzed with methods D5185, D445, D664, D4739, D6304, and ASTM E168 (FTIR) using the fingerprint method to obtain oxidation and nitration.

11.3.3.3 All 60 ml oil samples should be analyzed with methods D5185, D445, D664, D4739, D3525, D6304, and ASTM E168 (FTIR) using the fingerprint method to obtain oxidation and nitration.

11.3.3.4 At oil sampling intervals, test time is not accumulated and the engine is operated at stage 1 conditions. Using the oil sampling port shown in Fig. 8, Remove a 240 ml purge sample into the return oil assembly device (part # OHTIVB-020-1) and then return it at the oil cap location using the same device shown in Fig. 9.

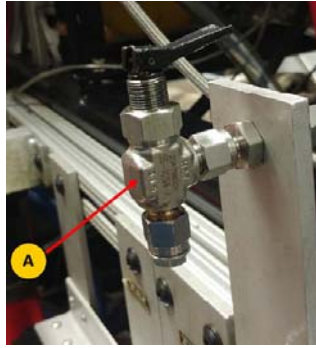

Fig. 8 Oil sampling port valve (A)



Fig. 9 Oil purge return device (A) connected to the quick connect cap (B)

11.3.3.5 After the purge, take the volume of oil sample specified by the test hour and the instructions in step 11.2.3.4 and return the engine to test conditions. This step should be completed within 10 min of the oil sampling conditions being achieved. If that is not possible, the engine should be shutdown.

11.3.3.6 After 200 h, which should be approximately 24000 cycles, the test is concluded.

11.3.4 Shutdowns and test resumes—Shutdowns are permitted in both emergency and non-emergency situations. Non-emergency situations include any event where the shutdown is not immediate.

NOTE 10—Test time is not accumulated during non-emergency shutdowns or any resume steps. Shutdowns and resumes are permitted during break-in, aging, silicone pacification, or test operation.

11.3.4.1 Non-emergency engine shutdown procedure—The following shutdown sequence should be conducted in a non-emergency shutdown:

- Reduce speed and load to stage 1 conditions. Engine load and speed is ramped and stabilized within the first 45 s and 60 s respectively. Operate at stage 1 conditions for a maximum of 10 min.
- Power off the electric fuel pump, and allow the engine to run for 5 s. Then, power off the ignition circuit to stop the engine.
- Manually open the starter disconnect switch (off position). Turn on the manual emergency stop switch.
- If a shutdown occurred during engine oil system flush mode or test mode, you may allow the engine coolant and rocker arm cover coolant pumps to remain on with the engine coolant flow and rocker arm cover coolant flow control valves fully open and the engine coolant heater controlling engine coolant out temperature to 52 °C and rocker arm cover heat exchanger controlling rocker arm cover coolant out temperature to 20 °C.

Comment [k28]: Added 8/30/17

- In the event of a shutdown lasting more than 30 min, it is permissible to turn off the engine coolant heater, the engine coolant pump and the rocker arm cover coolant pump in order to conserve power and place the test stand in a non-operative mode. The test laboratory may elect to turn off the load cell heater, as well.

11.3.4.2 If desired, a diagnostic oil level may be taken following an engine shutdown. Oil levels should be taken after the engine has been off for 10 minutes.

11.3.4.3 Following any non-end-of-test shutdown, restart the engine with stage 1 operating targets and run for at least 3 min and until reaching a coolant out temperature of at least 50°C and an oil gallery temperature of at least 50 °C. If these targets are still not achieved after 10 minutes, proceed to test. Engine load and speed is ramped and stabilized within the first 45 s and 60 s respectively when starting the engine.

11.3.4.4 If a test shutdowns due to cam lobe failure(s), that test cannot be resumed and is deemed non-interpretable.

11.3.4.5 Any engines that experience lobe failure must be removed from service for full inspection of bearing and cylinder liner surfaces. A full rebuild with new main and rod bearings must be conducted in accordance with Assembly Manual Section 4 before an engine can be returned to service.

11.4 Post-test procedures

11.4.1 Optional oil level procedure— After 200 h of test operation and the final oil sample, allow the engine to run at stage 1 conditions for 10 min before shutting down. Let the engine rest turned off for 10 min and then measure the end-of-test oil level using the OHT IVB dipstick (see Fig. 10) inserted into the side of the oil pan.



Figure 10

11.4.2 Check the engine's compression and leak-down.

11.4.3 Oil consumption— Drain the test oil from the oil pan drain plug and the two-external oil system heat exchanger drain valves for 30 min.

11.4.3.1 Weigh the drained test oil and calculate the oil consumption for the test by finding the difference between the initial charge and final drain and then subtracting the mass of the intermediate oil samples from that value. The initial 2600 g oil charge is equivalent to 3000 ml and that mass to volume ratio is used to calculate the mass of the intermediate 60 ml oil samples. Therefore, the final oil consumption would be calculated by the formula:

oil consumption = (2600 g – final oil drain mass) – (8 samples x 60 ml/per sample x 2600 g / 3000 ml)

11.4.4 Fuel consumption— Document how much fuel was consumed over the course of the test.

Fuel Consumption = Fuel Consumed at End of Test – Fuel Consumed at Start of Test

11.4.5 Post-test wear measurements:

11.4.5.1 All volume loss measurements are to be conducted with a Keyence 3D macroscope in accordance with the IVB Keyence VR-3200 Procedure, Annex A6.

Comment [k29]: Changed TCO to 50 and TLG to 50

Comment [k30]: Added 8/30/17

Comment [k31]: Exxon 80 ml?

Comment [k32]: Will be updated for the new software during the metrology workshop

12. Keywords

12. Precision and Bias

ANNEXES (Mandatory Information)



A.1 ASTM TEST MONITORING CENTER ORGANIZATION

A1.1 Nature and Functions of the ASTM Test Monitoring Center (TMC)—The TMC is a non-profit organization located in Pittsburgh, Pennsylvania and is staffed to: administer engineering studies; conduct laboratory inspections; perform statistical analyses of reference oil test data; blend, store, and ship reference oils; and provide the associated administrative functions to maintain the referencing calibration program for various lubricant tests as directed by TMC Subcommittee D02.B0 and the ASTM Executive Committee. The TMC coordinates its activities with the test sponsors, the test developers, the surveillance panels, and the testing laboratories. Contact TMC through the TMC Director at:

ASTM Test Monitoring Center
6555 Penn Avenue
Pittsburgh, PA 15206-4489
www.astmtmc.cmu.edu

A1.2 Rules of Operation of the ASTM TMC—The TMC operates in accordance with the ASTM Charter, the ASTM Bylaws, the Regulations Governing ASTM Technical Committees, the Bylaws Governing ASTM Committee D02, and the Rules and Regulations Governing the ASTM Test Monitoring System.

A1.3 Management of the ASTM TMC—The management of the Test Monitoring System is vested in the Executive Committee elected by Subcommittee D02.B0. The Executive Committee selects the TMC Director who is responsible for directing the activities of the TMC.

A1.4 Operating Income of the ASTM TMC—The TMC operating income is obtained from fees levied on the reference oils supplied and on the calibration tests conducted. Fee schedules are established by the Executive Committee and reviewed by Subcommittee D02.B0.

A2. ASTM TEST MONITORING CENTER: CALIBRATION PROCEDURES

A2.1 Reference Oils—These oils are formulated or selected to represent specific chemical, or performance levels, or both. They are usually supplied directly to a testing laboratory under code numbers to ensure that the laboratory is not influenced by prior knowledge of acceptable results in assessing test results. The TMC determines the specific reference oil the laboratory shall test.

A2.1.1 Reference Oil Data Reporting – Test laboratories that receive reference oils for stand calibration shall submit data to the TMC on every sample of reference oil they receive. If a shipment contains any missing or damaged samples, the laboratory shall notify the TMC immediately.

A2.2 Calibration Testing:

A2.2.1 Full-scale calibration testing shall be conducted at regular intervals. These full-scale tests are conducted using coded reference oils supplied by the TMC. It is a laboratory's responsibility to keep the on-site reference oil inventory at or above the minimum level specified by the TMC test engineers.

A2.2.2 Test Stands Used for Non-Standard Tests—If a non-standard test is conducted on a previously calibrated test stand, the laboratory shall conduct a reference oil test on that stand to demonstrate that it continues to be calibrated, prior to running standard tests.

A2.3 Reference Oil Storage—Store reference oils under cover in locations where the ambient temperature is between -10 °C and +50 °C.



A2.4 Analysis of Reference Oil—Unless specifically authorized by the TMC, do not analyze TMC reference oils, either **DXXXX 17** physically or chemically. Do not resell ASTM reference oils or supply them to other laboratories without the approval of the TMC. The reference oils are supplied only for the intended purpose of obtaining calibration under the ASTM Test Monitoring System. Any unauthorized use is strictly forbidden. The testing laboratory tacitly agrees to use the TMC reference oils exclusively in accordance with the TMC’s published Policies for Use and Analysis of ASTM Reference Oils, and to run and report the reference oil test results according to TMC guidelines. Additional policies for the use and analysis of ASTM Reference Oils are available from the TMC.

A2.5 Conducting a Reference Oil Test—When laboratory personnel are ready to run a reference calibration test, they shall request an oil code via the TMC website.

A2.6 Reporting Reference Oil Test Results—Upon completion of the reference oil test, the test laboratory transmits the data electronically to the TMC, as described in Section 13. The TMC reviews the data and contacts the laboratory engineer to report the laboratory’s calibration status. All reference oil test results, whether aborted, invalidated, or successfully completed, shall be reported to the TMC.

A2.6.1 All deviations from the specified test method shall be reported.

A3. ASTM TEST MONITORING CENTER: MAINTENANCE ACTIVITIES

A3.1 Special Reference Oil Tests—To ensure continuous severity and precision monitoring, calibration tests are conducted periodically throughout the year. Occasionally, the majority or even all the industry’s test stands will conduct calibration tests at roughly the same time. This could result in an unacceptably large time frame when very few calibration tests are conducted. The TMC can shorten or extend calibration periods as needed to provide a consistent flow of reference oil test data.

Adjustments to calibration periods are made such that laboratories incur no net loss or gain in calibration status.

A3.2 Special Use of the Reference Oil Calibration System—The surveillance panel has the option to use the reference oil system to evaluate changes that have potential impact on test severity and precision. This option is only taken when a program of donated tests is not feasible. The surveillance panel and the TMC shall develop a detailed plan for the test program. This plan requires all reference oil tests in the program to be completed as close to the same time as possible, so that no laboratory/stand calibration status is left pending for an excessive length of time. To maintain the integrity of the reference oil monitoring system, each reference oil test is conducted to be interpretable for stand calibration. To facilitate the required test scheduling, the surveillance panel may direct the TMC to lengthen and shorten reference oil calibration periods within laboratories such that the laboratories incur no net loss or gain in calibration status. To ensure accurate stand, or laboratory, or both severity assessments, conduct non-reference oil tests the same as reference oil tests.

A3.3 Donated Reference Oil Test Programs—The surveillance panel is charged with maintaining effective reference oil test severity and precision monitoring. During times of new parts introductions, new or re-blended reference oil additions, and procedural revisions, it may be necessary to evaluate the possible effects on severity and precision levels. The surveillance panel may choose to conduct a program of donated reference oil tests in those laboratories participating in the monitoring system, to quantify the effect of a particular change on severity and precision. Typically, the surveillance panel requests its panel members to volunteer enough reference oil test results to create a robust data set. Broad laboratory participation is needed to provide a representative sampling of the industry. To ensure the quality of the data obtained, donated tests are conducted on calibrated test stands. The surveillance panel shall arrange an appropriate number of donated tests and ensure completion of the test program in a timely manner.

A3.4 Intervals Between Reference Oil Tests—Under special circumstances, such as extended downtime caused by industry-wide parts or fuel shortages, the TMC may extend the intervals between reference oil tests.

A3.5 Introducing New Reference Oils—Reference oils produce various results. When new reference oils are selected, participating laboratories will be requested to conduct their share of tests to enable the TMC to recommend industry test targets. ASTM surveillance panels require a minimum number of tests to establish the industry test targets for new reference oils.



A3.6 TMC Information Letters—Occasionally it is necessary to revise the test method, and notify the test laboratories of the **DXXXX 18** change, prior to consideration of the revision by Subcommittee D02.B0. In such a case, the TMC issues an Information Letter. Information Letters are balloted semi-annually by Subcommittee D02.B0, and subsequently by D02. By this means, the Society due process procedures are applied to these Information Letters.

A3.6.1 Issuing Authority—The authority to issue an Information Letter differs according to its nature. In the case of an Information Letter concerning a part number change which does not affect test results, the TMC is authorized to issue such a letter. Long-term studies by the surveillance panel to improve the test procedure through improved operation and hardware control may result in the issuance of an Information Letter. If obvious procedural items affecting test results need immediate attention, the test sponsor and the TMC issue an Information Letter and present the background and data supporting that action to the surveillance panel for approval prior to the semiannual Subcommittee D02.B0 meeting.

A3.7 TMC Memoranda—In addition to the Information Letters, supplementary memoranda are issued. These are developed by the TMC and distributed to the appropriate surveillance panel and participating laboratories. They convey such information as batch approvals for test parts or materials, clarification of the test procedure, notes and suggestions of the collection and analysis of special data that the TMC may request, or for any other pertinent matters having no direct effect on the test performance, results, or precision and bias.

A4. ASTM TEST MONITORING CENTER: RELATED INFORMATION

A4.1 New Laboratories—Laboratories wishing to become part of the ASTM Test Monitoring System will be requested to conduct reference oil tests to ensure that the laboratory is using the proper testing techniques. Information concerning fees, laboratory inspection, reagents, testing practices, appropriate committee membership, and rater training can be obtained by contacting the TMC Director.

A4.2 Information Letters: COTCO Approval—Authority for the issuance of Information Letters was given by the committee on Technical Committee Operations in 1984, as follows: “COTCO recognizes that D02 has a unique and complex situation. The use of Information Letters is approved providing each letter contains a disclaimer to the effect that such has not obtained ASTM consensus. These Information Letters should be moved to such consensus as rapidly as possible.”

A4.3 Precision Data—The TMC determines the precision of test methods by analyzing results of calibration tests conducted on reference oils. Precision data are updated regularly. Current precision data can be obtained from the TMC.



ANNEX A.5 Lifter Measurements

A5.1 Preparing Pre-Test Lifters for Measurement:

A5.1.1 Record the following information for each lifter:

A5.1.1.1 Unique ID number engraved on the inside

A5.1.1.2 Lifter grade

A5.1.1.3 Position in the engine (including intake or exhaust side)

A5.1.2 This information needs to be properly documented and updated as needed throughout the course of the test.

A5.1.2.1 An example of this documentation is shown in Table A5.1.

Table A5.1 - Example of Lifter Identification Documentation

Intake Side								
Position	1	2	3	4	5	6	7	8
ID No.								
Grade								
Exhaust Side								
Position	1	2	3	4	5	6	7	8
ID No.								
Grade								

A5.1.3 Clean the lifters using pentane or heptane and allow the solvent to evaporate before taking any measurements.

A5.2 Measure the Pre-Test Lifter Weights:

A5.2.1 Use a calibrated scale to measure and record the weight of the lifters.



A5.2.2 These weights are to be reported to four decimal places in units of grams.

A5.2.3 A Mettler AE200 Analytical Balance is recommended for these measurements.

A5.3 Confirm Center Position of OHT Fixture:

A5.3.1 Place a dimpled reference lifter on the OHT fixture (Fig. A5.1).



Fig. 5.1 - OHT Lifter Fixture

A5.3.2 Preload the PDI stylus on the dimpled reference lifter so that its trace path is aligned with the dimple.

A5.3.3 Perform a trace of the dimpled reference lifter through the dimple.

A4.3.3.1 Move the stage or fixture as needed to find the lowest spot of the dimple.

A5.3.3.2 This will effectively center the OHT fixture.

A5.3.3.3 Save the trace of the dimpled lifter (through the lowest spot of the dimple) for future reference.

A5.4 Pre-Test Lifter Profile Traces:

A5.4.1 Profile traces are to be performed using a *Precision Devices, Inc. (PDI) MicroAnalyzer 2000* profilometer that is using the *Windows XP Version 3.6.15* operational software.

A5.4.2 Confirm that the TOYOTA_BUCKET.NDT template file is being used.

A5.4.3 Confirm the following settings on the *Delimitation* tab (Fig. A5.2):



- A5.4.3 (a) The **Find** checkbox is selected and the filter width is set to 0.400 mm under the **(A) Left Edge** field.
- A5.4.3 (b) The **Find** checkbox is selected and the filter width is set to 0.400 mm under the **(B) Right Edge** field.
- A5.4.3 (c) The **(C) Fix Truncation to Part Edges** checkbox is selected.
- A5.4.3 (d) The **(D) ASME B46.1-2002** standard is being used.

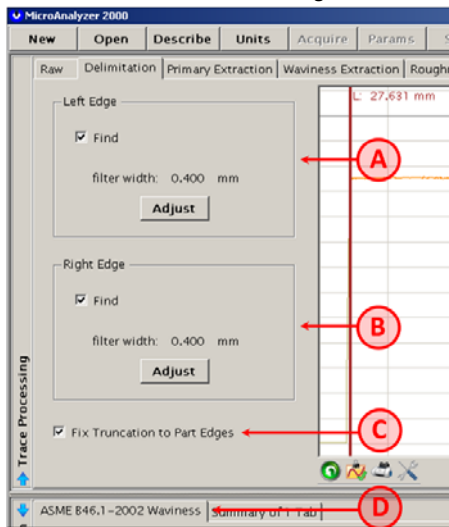

Fig. A5.2 - Delimitation Tab Settings

- A5.4.4 Confirm the following settings on the *Primary Extraction* tab (Fig. A5.3):
 - A5.4.4 (a) The **(E) Two-Point Line** radial button is selected under the *Form Removal* field.
 - A5.4.4 (b) The filter cutoff is set to **(F) 0.00 μm** under the *Shortwave Cutoff* field.

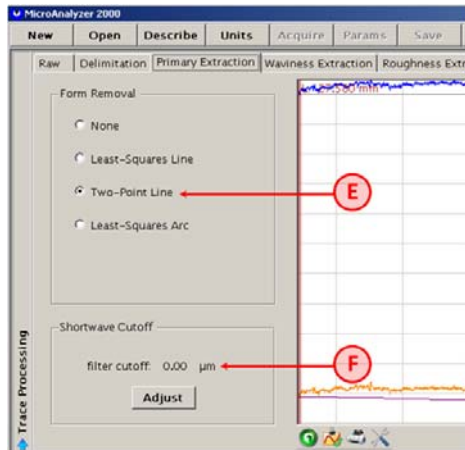

Fig. A5.3 - Primary Extraction Tab Settings

A5.4.5 Confirm the following settings on the *Waviness Extraction* tab (Fig. A5.4):

A5.4.5 (a) The (G) Gaussian w/o end removal radial button is selected under the *Waviness Short Cutoff* field.

A5.4.5 (b) The filter cutoff is set to (H) 0.800 mm under the *Waviness Short Cutoff* field.

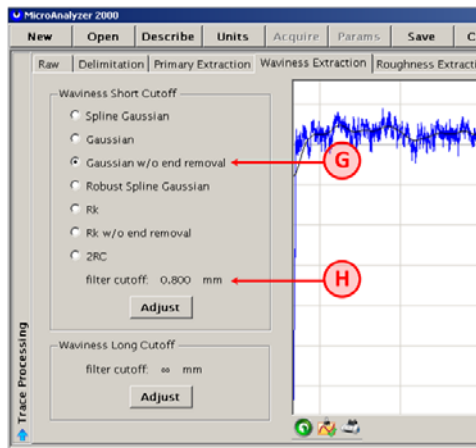

Fig. A5.4 - Waviness Extraction Tab Settings

A5.4.6 Confirm the following settings on the *Roughness Extraction* tab (Fig. A5.5):

A5.4.6 (a) The (I) Gaussian w/o end removal radial button is selected under the *Roughness Cutoff* field.

A5.4.6 (b) The filter cutoff is set to (J) 0.800 mm under the *Roughness Cutoff* field.

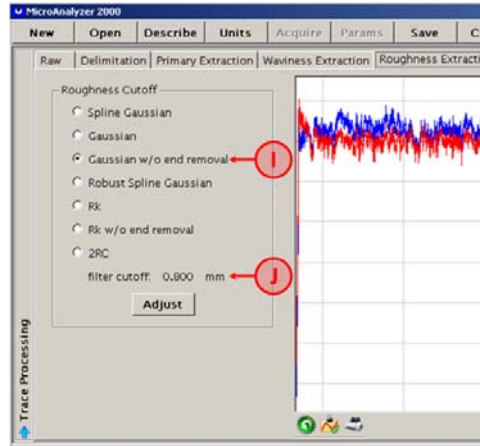

Fig. A5.5 - Roughness Extraction Tab Settings

A5.4.7 Place the notched lifter on the OHT fixture with the wear surface positioned upward:

A5.4.7.1 Profile traces are taken on two orthogonal lines as shown in Fig. A5.6.

A5.4.7.1 (a) The x-axis intersects the center of the lifter face near the middle of the ID number engraved on the inside of the lifter.

A5.4.7.1. (b) The y-axis also passes through the center of the wear surface and is perpendicular to the x-axis.

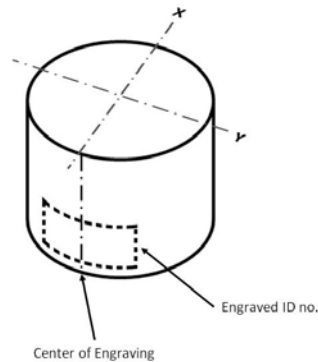

Fig. A5.6 - Orthogonal Lines Used for Lifter Profile Measurements

A5.4.8 Obtain a profile trace along one of the orthogonal lines by setting the OHT fixture in the "A" position.

A5.4.8.1 **NOTE:** The current orthogonal axis of the OHT fixture can be easily identified by the position of the removable pin.

Comment [HT33]: The figure is not correct and we find it easier to just use the laser etched marks.



A5.4.8.1 (a) For example, the OHT fixture is in the “A” position when the pin is near the “A” label on the black base plate.

A5.4.9 Level the trace using the two-point line on the *Primary Extraction* tab.

A5.4.9.1 Adjust the trace until its left and right edges are on the same horizontal level (as shown in Fig. A5.7).

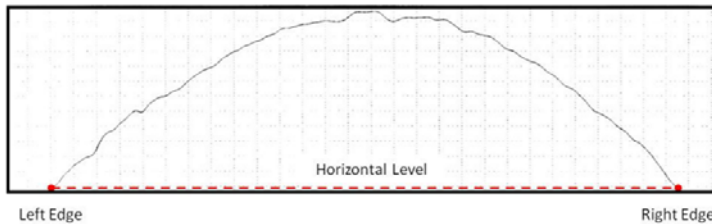

Fig. A5.7 - Leveling the Lifter Profile Trace

A5.4.10 Save the pre-test lifter traces using the unique file name that is assigned by the PDI software.

A5.4.10.1 Each laboratory is responsible for correlating this unique file name to the unique ID number assigned to each lifter.

A5.4.10.2 The laboratory must also correlate this file name to the orthogonal axis used for the trace (“A” or “B” as indicated on the OHT fixture).

A5.4.11 Record the pre-test **Wt** (waviness total) measurement (μm) with the waviness evaluation lines set on the extreme left-side and right-side edges of the waviness profile trace.

A5.4.12 Rotate the lifter 90-degrees and obtain a profile trace along the “B” position of the OHT fixture.

A5.4.12.1 Repeat Steps A5.4.9 through A5.4.11.

A5.4.13 Pre-test intake and Exhaust Lifters

A5.4.13.1 The acceptable pre-test waviness total for both intake and exhaust lifters is $0 \mu\text{m} < \text{Wt} < 15 \mu\text{m}$.

A5.4.13.2 It is up to the discretion of the metrology lab to reject any lifter with surface irregularities that are deemed to be unacceptable.

A5.5 Preparing Post-Test Lifters for Measurement:

A5.5.1 Clean the lifters using pentane or heptane and allow the solvent to evaporate before taking any measurements.

A5.6 Measuring the Post-Test Lifter Weights:

A5.6.1 Use a calibrated scale to measure and record the weight of the lifters.



A5.6.2 These weights are to be reported to four decimal places in units of grams.

A5.6.3 A Mettler AE200 Analytical Balance is recommended for these measurements.

A5.7 Post-Test Lifter Profile Traces:

A5.7.1 Confirm that the TOYOTA_BUCKET.NDT template file is being used.

A5.7.2 Confirm the following settings on the *Delimitation* tab (Fig. A5.2):

A5.7.2.1 The Find checkbox is selected and the filter width is set to 0.400 mm under the *Left Edge* field.

A5.7.2.2 The Find checkbox is selected and the filter width is set to 0.400 mm under the *Right Edge* field.

A5.7.2.3 The Fix Truncation to Part Edges checkbox is selected.

A5.7.2.4 The ASME B46.1-2002 standard is being used.

A5.7.3 Confirm the following settings on the *Primary Extraction* tab (Fig. A5.3):

A5.7.3.1 The Two-Point Line radial button is selected under the *Form Removal* field.

A5.7.3.2 The filter cutoff is set to 0.00 μm under the *Shortwave Cutoff* field.

A5.7.4 Confirm the following settings on the *Waviness Extraction* tab (Fig. A5.4):

A5.7.4.1 The Gaussian w/o end removal radial button is selected under the *Waviness Short Cutoff* field.

A5.7.4.2 The filter cutoff is set to 0.800 mm under the *Waviness Short Cutoff* field.

A5.7.5 Confirm the following settings on the *Roughness Extraction* tab (Fig. A5.5):

A5.7.5.1 The Gaussian w/o end removal radial button is selected under the *Roughness Cutoff* field.

A5.7.5.2 The filter cutoff is set to 0.800mm under the *Roughness Cutoff* field.

A5.7.6 Obtain a profile trace along both lifter's orthogonal axes (identified as "A" and "B" on the OHT fixture).

A5.7.7 Save the post-test lifter traces using the unique file name that is assigned by the PDI software.

A5.7.7.1 Each laboratory is responsible for correlating this unique file name to the unique ID number assigned to each lifter.

A5.7.7.2 The laboratory must also correlate this file name to the orthogonal axis used for the trace ("A" or "B" as indicated on the OHT fixture).

A5.8 Open the Comparator software.

A5.8.1 **NOTE:** All lifter profile comparisons are to be performed using *Version 3.0.3* of the Comparator software.

A5.9 Press the **(K)** Open Pre-button on the main Comparator screen (Fig. A5.9).

A5.9.1 Open the desired pre-test lifter trace document or documents.

A5.10 Press the **(L)** Open Post button on the main Comparator screen (Fig. A5.9).



A5.10.1 Open the corresponding post-test lifter trace document or documents.

A5.11 Use the **(N)** vertical adjustment lines and the **(O)** adjustment arrow buttons to level and align the pre-test and post-test traces (Fig. A5.9).

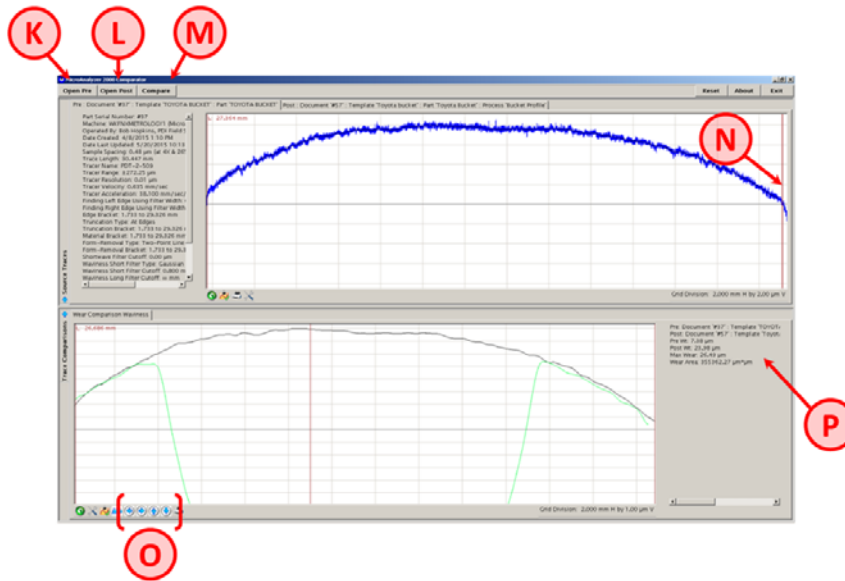

Fig. A5.9 - Main Comparator Screen

A5.12 Press the **(M)** Compare button on the main Comparator screen (Fig. A5.9).

A5.12.1 Select **(Q)** Wear Comparison Waviness from the *Comparison Type* pull down menu of the document selection screen (Fig. A510).

A5.12.2 Select the appropriate pre-test file **(R)** under the *Pre-Documents* field.

A5.12.3 Select the corresponding post-test file **(S)** under the *Post Documents* field.

A5.12.4 Press the **OK** button.

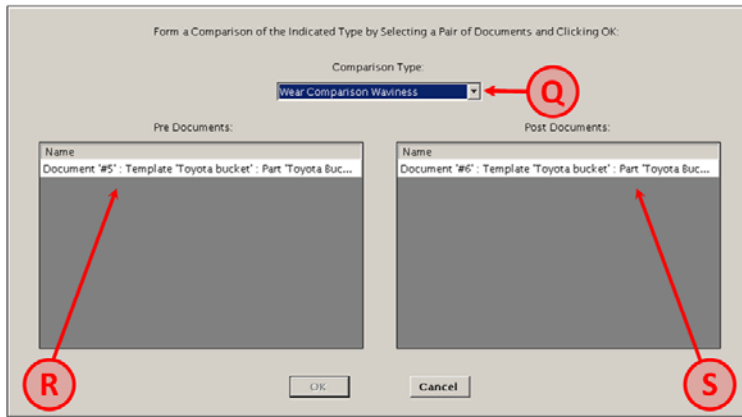

Fig. A5.10 - Comparator Software Document Selection Screen

A5.13 Record the required measurements (P, Fig. A5.9).

A5.13.1 **NOTE:** The Max Wear parameter is to be reported as z-diff.

A5.14 CAMSHAFT MEASUREMENTS

A5.14.1 Preparing Pre-Test Camshafts for Measurement:

A5.14.1.1 Spray the camshafts with Stoddard solvent.

A5.14.1.1 (a) Use a non-metallic brush to thoroughly scrub the lobe surfaces.

A5.14.1.1 (b) Dry the camshaft with compressed air.

A5.14.2 Visually inspect each camshaft lobe for defects or damage.

A5.14.2.1 Examples of such defects or damage are shown in Fig. A5.11.

A5.14.2.2 Reject any camshafts that have these abnormalities.

A5.14.3 Record the unique identification number for both the intake and exhaust camshafts.

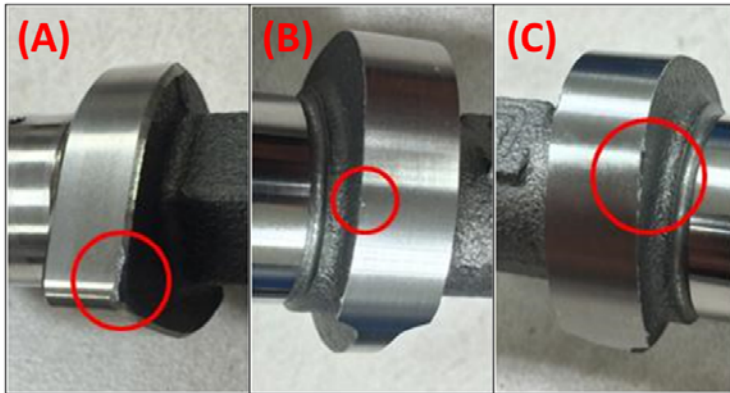

Fig. A5.11 - (A) Grinding Damage, (B) Pitting and (C) Shipping Damage

A5.14.4 Pre-Test Camshaft Diameter Measurements:

A5.14.4.1 Use a pin gage set to measure and record the diameter of all five oil feed holes on the journals of both the intake and exhaust camshafts (Fig. A5.12).

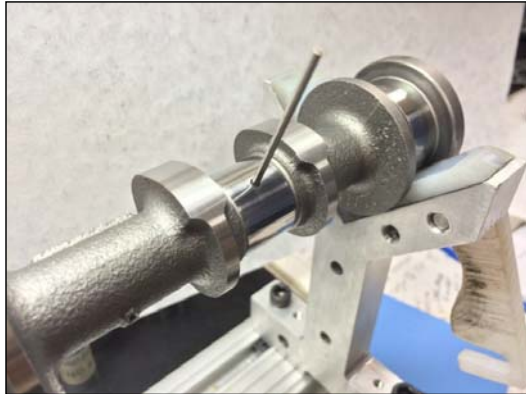

Fig. A5.12 - Measuring Oil Feed Hole Diameters Using a Pin Gage

A5.14.2 Place the camshaft on a V-Block fixture.

A5.14.2.1 The V-Blocks should be spaced so that each camshaft is supported on its 2nd and 5th journals.

A5.14.3 Place an indicator next to the camshaft so that the spindle head is in contact with Journal #3 and is orthogonal to the axis of the camshaft (Fig. A5.13).

A5.14.3.1 Rotate the camshaft until the indicator reads a minimum value.

A5.14.3.2 Zero the indicator.

A5.14.3.3 Rotate the camshaft again until the indicator reads a maximum value.

A5.14.3.4 Record this indicator measurement as the run-out of Journal #3.



- A5.14.3.5 Repeat these steps to obtain the run-out measurement for Journal #4.
- A5.14.3.6 Average the run-out measurements of Journal #3 and Journal #4 to calculate the overall run-out of the camshaft.
- A5.14.3.7 Repeat these steps for the second camshaft.

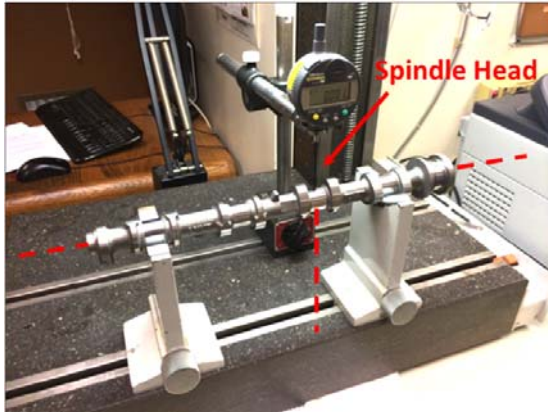

Fig. A5.13 - Correct Positioning of Indicator for Journal Run-Out Measurements

- A5.14.4 Reject any camshaft that has a run-out value that exceeds 0.04 mm (0.00157-in.).
- A5.14.5 Measure the diameter of Journal #1 with a 1 to 2 in. digital micrometer.
 - A5.14.5.1 A Mitutoyo Model #293-722-10 digital micrometer is recommended for these measurements.
 - A5.14.5.2 Measure the diameter of the journal along both its x-axis and y-axis (Fig. A5.14).
 - A5.14.5.3 **NOTE:** The x-axis passes through the center of the oil feed hole and intersects the center of the journal.
 - A5.14.5.4 **NOTE:** The y-axis is orthogonal to the x-axis.
 - A5.14.5.5 Record the average of the x-axis and y-axis diameter measurements for Journal #1.

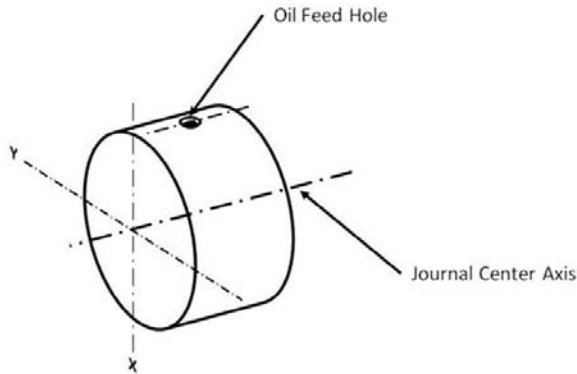

Fig. A5.14 - X and Y-Axis of Camshaft Journal

A5.14.6 Use a 0 to 1 in. digital micrometer to measure the diameter of Journal #2 through Journal #5.

A5.6.1 A Mitutoyo Model #293-721-10 digital micrometer is recommended for these measurements.

A5.14.7 Reject any camshafts with journal diameters that exceed the following specifications in Table 2:

Table 2 - Camshaft Journal Diameter Specifications

Item	Specified Condition
Journal #1	33.949 - 33.968 mm (1.3366 – 1.3372 in.)
Journal #2 - #5	22.949 – 22.965 mm (0.9035 – 0.9041 in.)

A5.15 Pre-Test Camshaft Lobe Heel-to-Toe Height:

A5.15.1 Place the camshaft on a V-Block fixture.

A5.15.1.1 The V-Blocks should be spaced so that each camshaft is supported on its 2nd and 5th journals.

A5.15.2 Calibrate a 1 to 2 in. snap gage using a cylindrical measurement standard.

A5.15.2.1 A Mitutoyo Model #201-152 snap gauge with a Mitutoyo Model #ID-C112AEB digital indicator attachment is recommended for these measurements.

A5.15.2.2 The cylindrical measurement standard used for intake camshaft lobe heel-to-toe measurements has a diameter of 36.725 mm.

A5.15.2.3 The cylindrical measurement standard used for exhaust camshaft lobe heel-to-toe measurements has a diameter of 39.500 mm.



A5.15.3 Set the base circle of the camshaft lobe on the anvil of the snap gage and engage the spindle (Fig. A5.15).

A5.15.3.1 While keeping the snap gage centered on the lobe, slowly rotate the snap gage around the lobe until the digital indicator reads a maximum value.

A5.15.3.2 Record this measurement as the heel-to-toe height for the specific camshaft lobe.

A5.15.3.3 Repeat this measurement for the eight camshaft lobes on both the intake and exhaust camshafts.



Fig. A5.15 - Positioning the Snap Gage to Measure the Camshaft Heel-to-Toe Height

A5.15.4 Reject any exhaust camshafts that have heel-to-toe heights that exceed the following specifications in Table 3:

A5.15.4.1 **NOTE:** There are currently no heel-to-toe height specifications for the intake camshafts.

Table 3 – Exhaust Camshaft Heel-to-Toe Height Specifications

Exhaust Cam Limits	Specified Condition
Standard Lobe Height	39.462-39.562 mm (1.554-1.558 in.)
Minimum Lobe Height	39.362 (1.550 in.)

A5.16 Pre-Test Camshaft Lobe Surface Profile Traces:

A5.16.1 Profile traces are to be performed using a Precision Devices, Inc. (PDI) MicroAnalyzer 2000 profilometer that is using the Windows XP Version 3.6.15 operational software.



A5.16.2 Confirm that the TOYOTA_CAM.NDT template file is being used.

A5.16.3 Confirm the following settings on the *Delimitation* tab:

A5.16.3.1 The Find checkbox is selected and the filter width is set to 0.400 mm under the *Left Edge* field.

A5.16.3.2 The Find checkbox is selected and the filter width is set to 0.400 mm under the *Right Edge* field.

A5.16.3.3 The Fix Truncation to Part Edges checkbox is selected.

A5.16.3.4 The ASME B46.1-2002 standard is being used.

A5.16.4 Confirm the following settings on the Primary Extraction tab:

A5.16.4.1 The Two-Point Line radial button is selected under the Form Removal field.

A5.16.4.2 The filter cutoff is set to 0.00 μm under the Shortwave Cutoff field.

A5.16.5 Confirm the following settings on the Waviness Extraction tab:

A5.16.5.1 The Gaussian radial button is selected under the Waviness Short Cutoff field.

A5.16.5.2 The filter cutoff is set to 0.800 mm under the Waviness Short Cutoff field.

A5.16.6 Confirm the following settings on the Roughness Extraction tab:

A5.16.6.1 The Gaussian radial button is selected under the Roughness Cutoff field.

A5.16.6.2 The filter cutoff is set to 0.800 mm under the Roughness Cutoff field.

A5.16.7 Place the camshaft on a V-Block fixture.

A5.16.7.1 The V-Blocks should be spaced so that each camshaft is supported on its 2nd and 5th journals.

A5.16.8 Move the stylus until it is over the camshaft lobe that is to be measured.

A5.16.8.1 Rotate the camshaft until the nose of the lobe is pointed toward the stylus.

A5.16.8.2 Lower the stylus onto the surface of the camshaft lobe.

A5.16.8.3 Slowly rotate the camshaft until the stylus reaches the point of highest displacement.

A5.16.8 Obtain a trace that spans the width of the camshaft lobe.

A5.16.8.1 Report the roughness average (Ra), skew (Rsk) and waviness (Wt).

A5.16.8.2 Save the pre-test traces using the appropriate file naming convention.

A5.16.8.3 Repeat the measurements for all eight camshaft lobes for both the intake and exhaust camshafts.



TABLE A.1 Engine Break-in Schedule

Break-in Step #	Duration, min	Engine Speed, rpm	Engine Load, N-m	Gallery Oil Temperature, °C	Coolant Out Temperature, °C
1	10	800	6.3	50	50
2	10	1600	6.3	55	50
3	10	2000	25.0	60	55
4	10	2400	25.0	65	60
5	10	2400	46.9	70	65
6	15	2800	46.9	75	70
7	15	3200	46.9	80	75
8	15	3200	68.8	85	80



TABLE A.2 Summary of Sequence IVB Test Operating Conditions

Parameter	Units	Ramp to Stage 1	Stage 1	Ramp to Stage 2	Stage 2
Duration	s	8	7	8	7
Engine Speed	Rpm	4300 to 800	800	800 to 4300	4300
Engine Torque	N-m	25 ± 1.5	25 ± 1.5	25 ± 1.5	25 ± 1.5
Coolant Out Temperature	°C	52 ± 1.5?	52 ± 1.5?	52 ± 1.5?	52 ± 1.5?
Coolant Flow (Engine)	L/min	80 ± 0.4	80 ± 0.4	80 ± 0.4	80 ± 0.4
Coolant Flow (RAC)	L/min	120 ± 0.75	120 ± 0.75	120 ± 0.75	120 ± 0.75
Oil Gallery Temperature	°C	54 ± 5	54 ± 5	54 ± 5	54 ± 5
RAC Coolant Out Temperature	°C	20 ± 0.75	20 ± 0.75	20 ± 0.75	20 ± 0.75
Fuel Rail Temperature	°C	24 ± 0.5	24 ± 0.5	24 ± 0.5	24 ± 0.5
Load Cell Temperature	°C	45 ± 4	45 ± 4	45 ± 4	45 ± 4
Intake Air Temperature	°C	32 ± 0.75	32 ± 0.75	32 ± 0.75	32 ± 0.75
Blowby Gas Temperature	°C	29 ± 0.5	29 ± 0.5	29 ± 0.5	29 ± 0.5
Intake Air Pressure	kPa	0.25 ± 0.25	0.25 ± 0.25	0.25 ± 0.25	0.25 ± 0.25
Intake Air Humidity	g/kg	11.5 ± 0.5	11.5 ± 0.5	11.5 ± 0.5	11.5 ± 0.5
Exhaust Pressure	kPaA	-	-	-	104.5 ± 3
Engine Coolant Pressure	kPa	70 ± 10	70 ± 10	70 ± 10	70 ± 10
Fuel Rail Pressure	kPa	335 ± 10	335 ± 10	335 ± 10	335 ± 10
Air-to-Fuel Ratio (Not Controlled)	:1	Record	14.5 ± 0.5	Record	14.5 ± 0.5



TABLE A.3 RPM Setpoints and QI Control Limits

Cycle Time, s	Setpoint, rpm	U, rpm	L, rpm
1	800	950	650
2	800	900	700
3	800	875	725
4	800	850	750
5	800	850	750
6	800	850	750
7	800	850	750
8	927	1077	777
9	1357	1607	1107
10	1888	2288	1488
11	2300	2700	1900
12	2731	3131	2331
13	3168	3568	2768
14	3610	4010	3210
15	4041	4441	3641
16	4300	4400	4200
17	4300	4375	4225
18	4300	4350	4250
19	4300	4325	4275
20	4300	4325	4275
21	4300	4325	4275
22	4300	4325	4275
23	4136	4236	4036
24	3734	3984	3484
25	3283	3683	2883
26	2829	3229	2429
27	2382	2782	1982
28	1946	2346	1546
29	1523	1923	1123
30	1116	1516	716



ANNEX A6

KEYENCE VR-3000

A6.1 HARDWARE AND SOFTWARE REQUIREMENTS:

A6.1.1 Hardware: Keyence VR-3000

A 6.1.2 Software: Generation-2

A6.2 TEMPLATE AND SETTINGS:

A6.2.1 Viewer Settings:

A6.2.1.1 The Viewer settings file 40X-SETTINGS.zon is available on the TMC website.

A6.2.1.2 This file will establish the following settings in the Viewer:

A6.2.1.2 (a) High mag cam

A6.2.1.2 (b) 40X magnification

A6.2.1.2 (c) *Mode: Standard*

A6.2.1.2 (d) *Measurement direction: Both sides*

A6.2.1.2 (e) *Adjust brightness for measurement: Auto*

A6.2.1.2 (f) *Sets stitching area.*

A6.2.2 Analyzer:

A6.2.2.1 The Analyzer template file 40X TEMPLATE-RING.zcs is available on the TMC website.

NOTE A6.1: This template file is set up like the original 25X template to accommodate a larger file size.

NOTE A6.2: The new template is designed to replicate the original template that was used for the Generation-1 software.

A6.2.3 Confirm the Following Settings:

A6.2.3.1 *Auto-Position Settings:*

A6.2.3.1 (a) *Auto-position adjustment:* On

A6.2.3.1 (b) *Select position alignment image:* Height

A6.2.3.1 (c) *Restrict rotation search range when aligning position:* Restrict to 0-degrees

A6.2.4 *Reference Plane:*

A6.2.4.1 The leveling ring in the original template was undefined.

A6.2.4.2 The leveling ring in this template is bounded by an area between 26.950-27.050 mm.

A6.2.5 *Height Range Settings:*

A6.2.5.1 *Set at:* -0.010mm to +0.10mm

A6.2.5.2 This allows the user to see features at a glance.

A6.2.6 *Volume Measurement:*

A6.2.6.1 The area for measurement in the original template was undefined.

A6.2.6.2 The area for measurement in this template is a 27 mm circle.

A6.2.6.3 *Height threshold:* -0.050mm (identical to original template)

A6.2.6.4 *Ignore small areas:* Enabled



A6.2.7 High-Spot Measurement:

- A6.2.7.1 The area for measurement in the original template was undefined.
- A6.2.7.2 The area for measurement in this template is a 27 mm circle.
- A6.2.7.3 *Height threshold:* 0.010 mm
- A6.2.7.4 *Ignore small areas:* Enabled

A6.3 ADDENDUM A - CALIBRATION:

A6.3.1 Recommended Calibration and Verification Frequencies:

- A6.3.1.1 The manufacturer recommends verifying the calibration every time the microscope is used.
- A6.3.1.2 The manufacturer recommends updating the calibration approximately one time per month.
- A6.3.1.3 All the manufacturer's calibration documentation can be found in the *Viewer Software Reference Manual VR-HIV*.

NOTE A6.3: The microscope must be allowed to warm-up for 30 min before performing a calibration or verification check.

Comment [k34]: Changed from 1 hour

Comment [k35]: Agreed during 8/29 conference call



A7. THERMOCOUPLES

A7.1 This annex illustrates the locations of the required IVB thermocouples which are supplied by Test Engineering Inc. Locate the sensing tip of all thermocouples in the center of the stream of the medium being measured unless otherwise specified.

TABLE A5 Thermocouple List

#	Description	Thermocouple Size
1	Engine Coolant Out	E-Type 1/8" x 4"
2	Engine Coolant In	E-Type 1/8" x 4"
3	Engine Oil Gallery	E-Type 1/8" x 4"
4	Load Cell	E-Type 1/8" x 4"
5	Intake Air	E-Type 1/8" x 4"
6	Test Cell	E-Type 1/8" x 2"
7	Fuel	E-Type 1/8" x 4"
8	Oil Sump	E-Type 1/8" x 3"
9	Valve Cover Gas Out	E-Type 1/8" x 4"
10	Valve Cover Coolant In	E-Type 1/8" x 4"
11	Valve Cover Coolant Out	E-Type 1/8" x 4"
12	Exhaust Gas	E-Type 1/4" x 4"
13	Dynamometer Coolant Out	E-Type 1/8" x 4"
14	Blow-by Gas	E-Type 1/8" x 4"
15	Blow-by Coolant Out	E-Type 1/8" x 3"

Each Fig. shall have an explanation in this Annex!

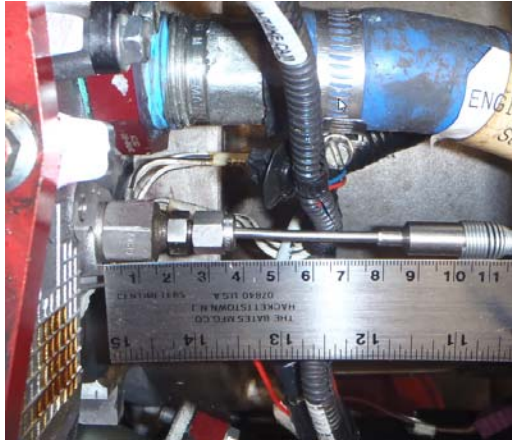

Figure A7. 1 Engine Coolant Out

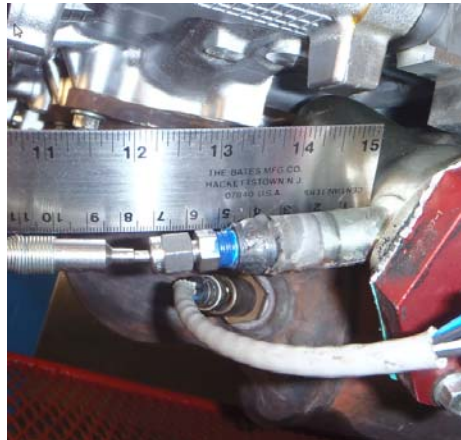

Figure A7. 2 Engine Coolant In



Figure A7. 3 Engine Oil Gallery



Figure A7. 4 Load Cell

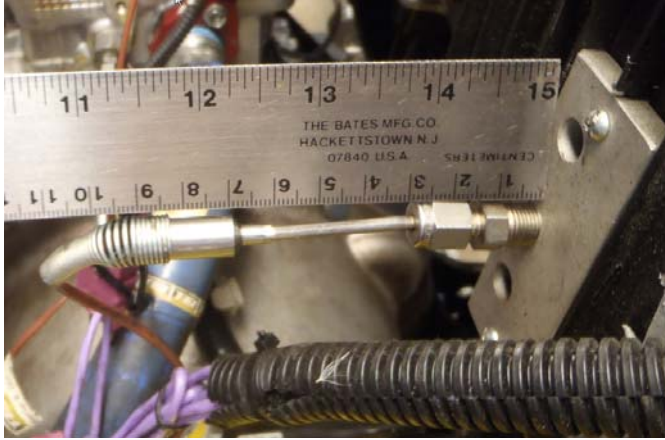

Figure A7. 5 Intake Air

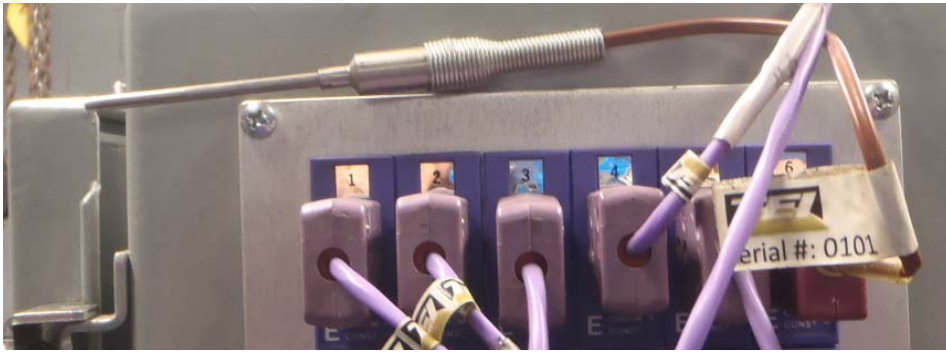

Figure A7. 6 Test Cell

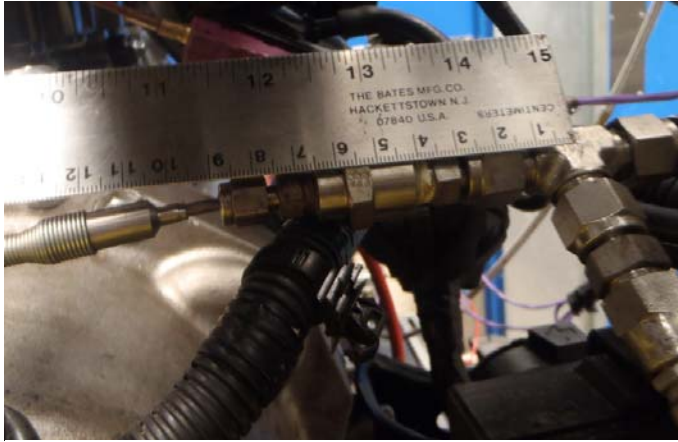

Figure A7. 7 Fuel

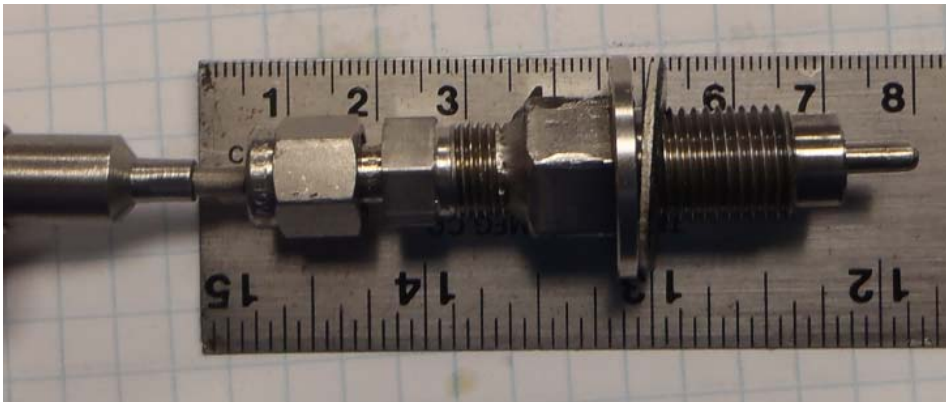

Figure A7. 8 Oil Sump

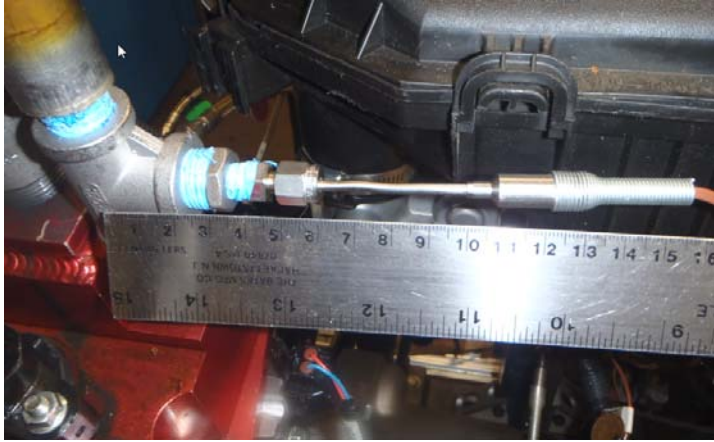

Fig. A7. 9 Valve Cover Gas

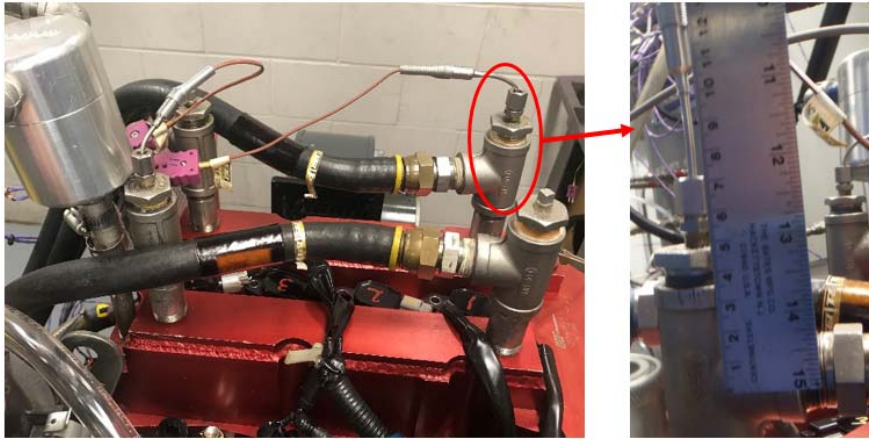

Fig. A7. 10 Valve Cover Coolant In

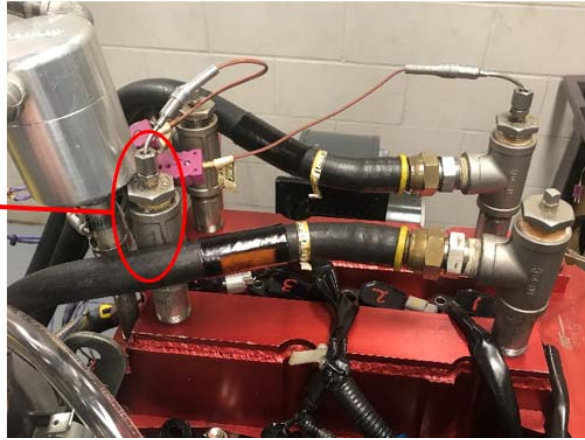

Figure A7.11 Valve Cover Coolant Out



Figure A7.12 Exhaust Gas



Figure A7.13 Dynamometer
Coolant Out



Figure A7.14 Blow-by Gas

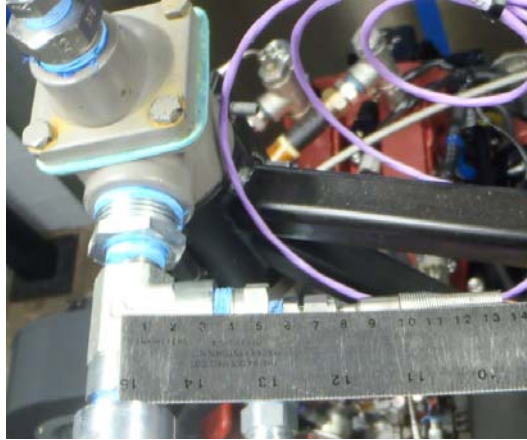
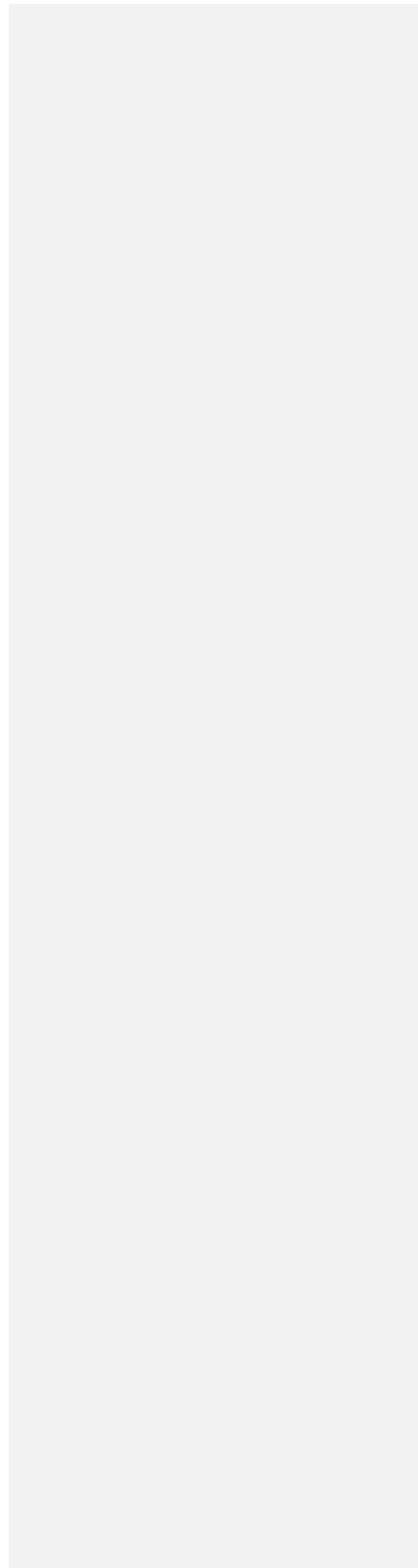
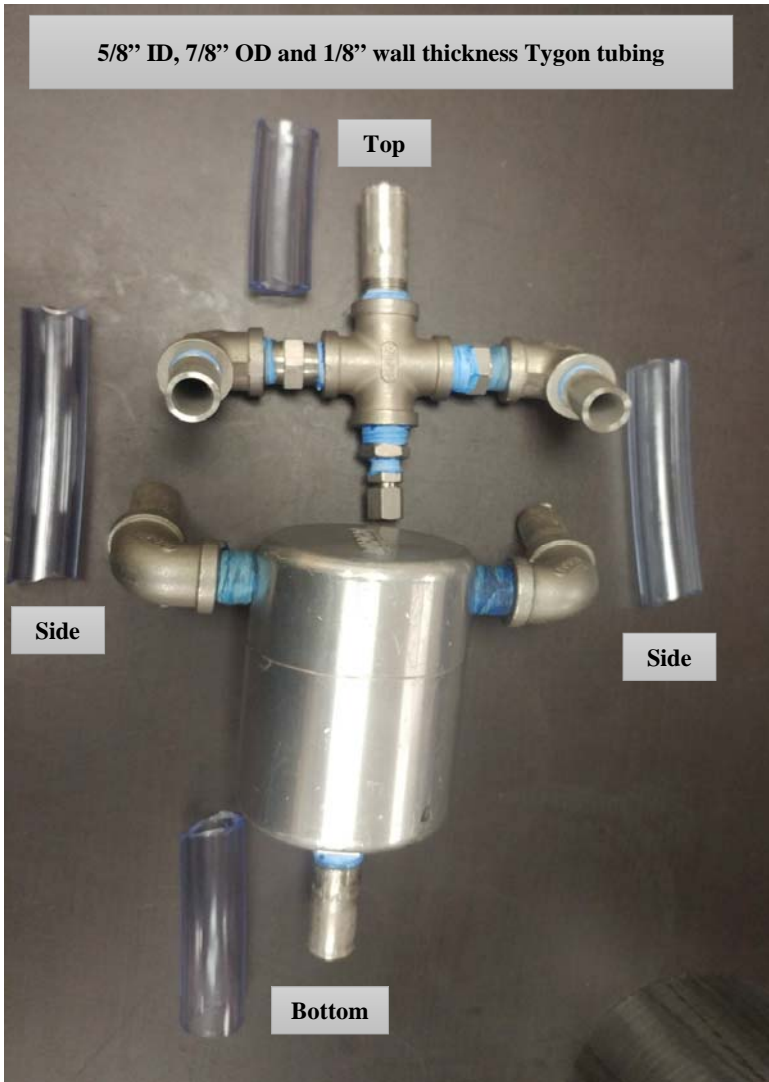

Figure A7. 15 Blow-by Coolant Out



Tygon Hose Sections



Oil separator side hoses, 2 each, 4 inches long.



Oil separator bottom hose, 3 inches long.



Oil separator top hose, 2 ½ inches long.



Oil Separator Insulation

Foam used for insulating oil separator.

Ultra-Flexible Foam Rubber Insulation

Plain Back, 3/4" Thick, 36" x 48" Sheet, Black



Part # 9349K3

Insulation Type	Sheet/Strip
Thickness	3/4"
Width	36"
Length	4 ft.
Temperature Range	-295° to 220° F
R Value	3
Heat Flow Rate	0.25 @ 75° F
Density	4.5 lbs./cu. ft.
Material	Buna-N/PVC Foam
Flexibility	Flexible
Cell Type	Closed
Backing Type	Plain
Color	Black
For Use Outdoors	No
Specifications Met	ASTM E84 25/50 for Flame and Smoke
Additional Specifications	SDS
RoHS	Compliant
Related Products	Contact Adhesive (16 oz.) White Latex Paint (1 qt.)

These soft Buna-N/PVC foam insulation sheets are extremely flexible. They can be used outdoors if coated in latex paint. The foam has a closed-cell construction, which restricts absorption of water, air, and gas. Install plain-back insulation using contact adhesive (sold separately).

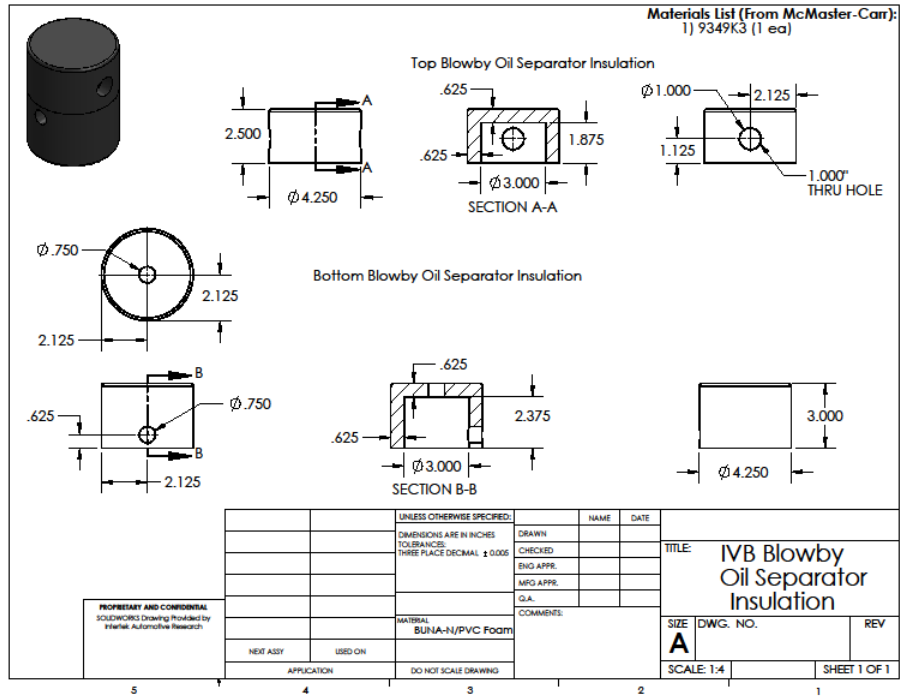

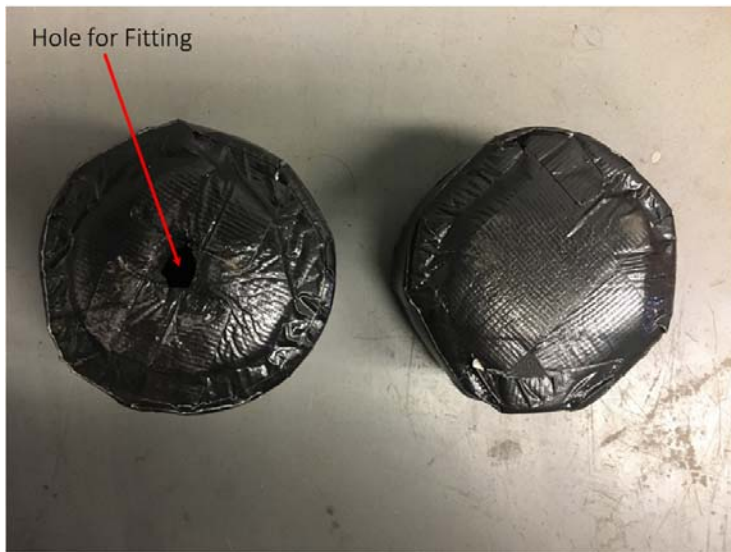
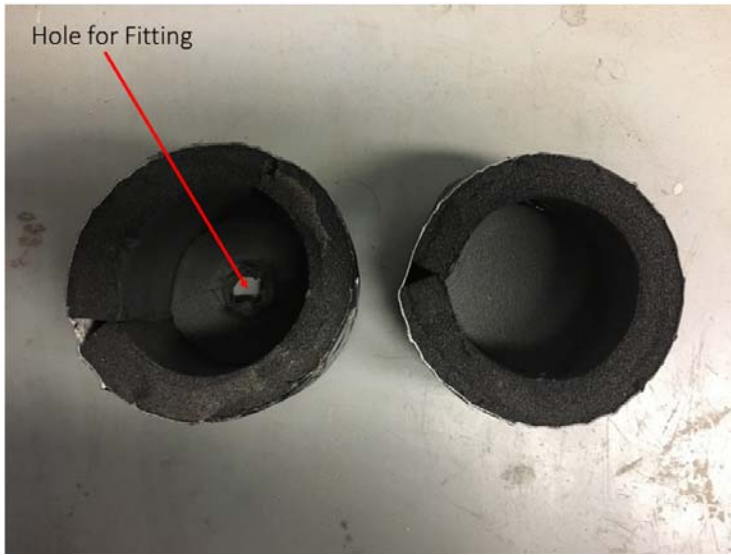

Tape the foam on the oil separator.



Tygon Hose Insulation

Foam used on hoses.

Ultra-Flexible Foam Rubber Pipe Insulation

1/2" Thick, 1-1/8" Insulation ID, 6' Length



Part # 4463K136

Insulation Type	Tube
Wall Thickness	1/2"
ID	1 1/8"
For Pipe Size	3/4
Length	6 ft.
Temperature Range	-295° to 220° F
Heat Flow Rate	0.25 @ 75° F
Density	4.5 lbs./cu. ft.
Material	Buna-N/PVC Foam
Flexibility	Flexible
Tube Style	Un-slit
Color	Black
For Use Outdoors	No
Specifications Met	ASTM C534, ASTM E84 25/50 for Flame and Smoke
R Value	2
Additional Specifications	SDS
RoHS	Compliant

The soft Buna-N/PVC foam construction flexes for effortless installation over curved and irregular objects and bounces back to shape after compression. Use these tubes on chilled water and refrigeration lines and with hot water plumbing. They can be used outdoors if you coat them in latex paint and seal the seams and joints with contact adhesive (both sold separately). The foam has a closed-cell construction, which restricts absorption of water, air, and gas.

Make 2 insulating tubes to cover the side hoses.

Cut one end at 30 degree angle.

Cut the other end at 90 degrees for an overall length of 11 inches.



Side Hose Insulation

The use of smaller hose clamps makes assembly easier.



Install the Tygon side hoses then slide the side insulation side pieces pointed end towards the separator.



Compress insulation and tighten hose clamp then repeat on the other side.



Slide the side insulation to the cross.



Install the top Tygon hose.



Top Hose Insulation

Cut a 2 inch notch. Cut the overall length at 5 inches.



Install the top Tygon hose then Slide the insulation over the top hose.



Tape the side hose insulation to the oil separator.



Tape the top hose insulation to the side insulation pieces.



Install lower Tygon hose.



Install the assembly on test stand. Insure there is sufficient angle (approximately 4 degrees) to let the blowby liquids drain back into the oil separator. Trim upper and lower hoses no more than ½ inch to achieve the proper fit and angle.



Bottom Hose Insulation

After the separator is installed, slit a 6 inch piece of round insulation and cut a hole for the RAC Gas Out Temperature thermocouple.



Wrap the lower hose insulation around the lower hose and plumbing extending out of the rocker arm cover. Tape or zip tie the insulation to secure it in place.



Lower insulation installed with zip ties.



A9. List of Engine and Stand Parts supplied by OH Technologies INC.

Item	Description
IVB001-3	SHAFT, OUTPUT, TOYOTA, 1.5L, SEQ. IVB
IVB001-5	GUARD, FLYWHEEL, BELL HOUSING, SEQ. IVB (YELLOW)
IVB001-11	BEARING, PILOT, FLYWHEEL, SEQ. IVB
IVB002-11	ASSEMBLY, SEAL INSERT TOOL
IVB002-12	STUD, SHOULDER, FOR USE WITH OHTIVB-002-2
IVB003-2	CORD (O-RING), FRONT COVER, SEQ. IVB
IVB003-3	PLATE, ACCESS (INCLUDING STUDS, NUTS & LOCK WASHERS)
IVB003-4	GASKET, ACCESS PLATE, OHTIVB-003-1, COVER, FRONT
IVB004-1	GASKET, WATER PUMP PLATE, OHTIVB-003-1 COVER, FRONT
IVB005-1	GASKET, COOLANT OUT ADAPTER, SEQ. IVB
IVB007-1	GASKET, WATER PUMP, IN, ADAPTER, SEQ. IVB
IVB022-12	PLUG, DRAIN, MODIFIED, SEQ. IVB
IVB022-14	PLUG, DRAIN, ASSY, IVB
IVB022-20	O-RING, OIL PAN, FILTER CIRCUIT, BLOCK MATING SURFACE
IVB022-21	CORD (O-RING), OIL PAN (2 EACH PER PKG.)
IVB022-3	DIPSTICK, ASSEMBLY, SEQ. IVB
IVB13751-KEY	FIXTURE, LIFTER, KEYENCE, SEQ. IVB
IVB13751-SPACER	SPACER, FIXTURE, KEYENCE (REQUIRES 2 EACH PER FIXTURE ASSY.)
VH006-6	BEARING, BALL, OUTPUT SHAFT
OHTIVB-001-1	BELL HOUSING, ASSEMBLY, SEQUENCE IVB, TOYOTA
OHTIVB-002-2	COVER, ROCKER, WATER COOLED, SEQ. IVB
OHTIVB-004-1	PLATE, WATER PUMP BLOCK-OFF
OHTIVB-005-1	PLATE, COOLANT OUT ADAPTER, SEQ. IVB
OHTIVB-007-1	PLATE, WATER PUMP, IN, ADAPTER, SEQ. IVB
OHTIVB-01258-1	PLUG, SPARK
OHTIVB-020-1	CYLINDER, RETURN, OIL, ASSEMBLY, SEQ. IVB
OHTIVB-021-1	COOLANT, INLET TUBE, MODIFIED
OHTIVB-02101-1	SEAL, VALVE STEM
OHTIVB-02112-1	SEAL, VALVE STEM
OHTIVB-022-2	PAN, OIL MODIFIED, WITH MODIFIED PICKUP TUBE AND DIPSTICK, SEQ. IVB
OHTIVB-03028-1	LOCK, VALVE SPRING RETAINER,
OHTIVB-050-1	3,000ml ERLLENMEYER FLASK, AMBER FILLED, ETCHED RING @ 2,400ml, CALIBRATED
OHTIVB-051-1	4,000ml ERLLENMEYER FLASK, AMBER FILLED, ETCHED RING @ 3,000ml, CALIBRATED
OHTIVB-06997-1	BOLT, W/ WASHER
OHTIVB-06998-1	BOLT, W/ WASHER
OHTIVB-07033-1	O-RING, INJECTOR
OHTIVB-080-1	16000-47A70, ENGINE ASSY W/CLUTCH

OHTIVB-08026-1	BOLT, W/ WASHER, COVER, CLUTCH
OHTIVB-08052-1	STUD, HEX,
OHTIVB-08060-1	STUD, HEX,
OHTIVB-08146-1	NUT, STARTER
OHTIVB-08228-1	NUT, CYLINDER HEAD AND EXHAUST PIPE
OHTIVB-09031-1	O-RING, FRONT COVER
OHTIVB-100-1	KIT, GOLDEN STAND SETUP
OHTIVB-10010-1	TOOL, CRANKSHAFT PULLEY
OHTIVB-10016-1	NUT, FRONT/ INTAKE MOUNT
OHTIVB-10426-1	BOLT, WASHER BASED HEX, FRONT/INTAKE MOUNT
OHTIVB-10469-1	BOLT, FLANGE, RH ENGINE MOUNT & T/M HOUSING
OHTIVB-10889-1	BOLT, W/ WASHER,
OHTIVB-11101-1	HEAD SUB-ASSY, CYLINDER, SEQ. IVB
OHTIVB-11115-1	GASKET, CYLINDER HEAD, SEQ. IVB
OHTIVB-11191-1	TUBE, SPARK PLUG SEQ. IVB
OHTIVB-11193-1	GASKET, SPARK PLUG TUBE, SEQ. IVB
OHTIVB-11213-1	GASKET, CYLINDER HEAD COVER
OHTIVB-11310-1	COVER, FRONT OEM
OHTIVB-12031-1	GASKET, DRAIN PLUG
OHTIVB-12054-1	BOLT, WASHER BASED HEX, REAR/EXHAUST MOUNT
OHTIVB-12160-1	BOLT, WASHER BASED HEX HEAD
OHTIVB-12221-1	GASKET, WATER TEMP SENSOR
OHTIVB-12262-1	HOSE, VENTILATION NUMBER 2
OHTIVB-12305-1	INSULATOR SUB-ASSY, ENGINE
OHTIVB-12311-1	BRACKET, ENGINE MOUNTING, FRONT/INTAKE
OHTIVB-12321-1	BRACKET, ENGINE MOUNTING, REAR/EXHAUST
OHTIVB-12361-1	INSULATOR, ENGINE MOUNTING, INTAKE SIDE
OHTIVB-12371-1	INSULATOR, ENGINE MOUNTING
OHTIVB-13501-1	CAMSHAFT SUB-ASSY, NO. 1 INTAKE, SPECIAL TEST
OHTIVB-13502-1	CAMSHAFT, EXHAUST
OHTIVB-13506-1	CHAIN, SUB-ASSY,
OHTIVB-13521-1	SPROCKET, CRANKSHAFT TIMING
OHTIVB-13523-1	SPROCKET, CAMSHAFT TIMING
OHTIVB-13540-1	TENSIONER ASSY, CHAIN
OHTIVB-13540-2	TENSIONER ASSY, CHAIN
OHTIVB-13552-1	GASKET, CHAIN TENSIONER
OHTIVB-13566-1	GUIDE, TIMING CHAIN,
OHTIVB-13591-1	ARM, TIMING CHAIN TENSION
OHTIVB-13711-1	VALVE, INTAKE,
OHTIVB-13715-1	VALVE, EXHAUST,
OHTIVB-13734-1	SEAT, VALVE SPRING
OHTIVB-13741-1	RETAINER, VALVE SPRING

OHTIVB-15104-1	STRAINER, SUB ASSY, OIL PAN
OHTIVB-15695-1	BOLT, OIL COOLER UNION
OHTIVB-15710-1	COOLER, OIL
OHTIVB-16000-1	ENGINE, ASSY. 1.5L, L/ CLUTCH, SEQ. IVB
OHTIVB-16000-2	ENGINE, ASSY. 1.5L, L/ CLUTCH, SEQ. IVB
OHTIVB-16268-1	PIPE, COOLANT INLET, MODIFIED
OHTIVB-17173-1	GASKET, EXHAUST MANIFOLD
OHTIVB-17177-1	GASKET, INTAKE MANIFOLD TO HEAD
OHTIVB-17400-1	PIPE ASSY., EXHAUST
OHTIVB-17451-1	GASKET, EXHAUST PIPE
OHTIVB-17568-1	SUPPORT, EXHAUST PIPE, STAY,
OHTIVB-17700-1	CLEANER ASSY., AIR W/ ELEMENT, MODIFIED
OHTIVB-17751-1	PIPE, INLET, AIR CLEANER
OHTIVB-17801-1	FILTER, AIR, ELEMENT (FOR USE IN 17700-0Y060 AIR INLET HOUSING)
OHTIVB-19023-1	O-RING, FRONT COVER
OHTIVB-21041-1	NUT, FLANGE
OHTIVB-22030-1	BODY ASSY., THROTTLE W/ MOTOR
OHTIVB-22210-1	PEDAL, THROTTLE, MODIFIED, SPECIAL TEST, SEQ. IVB
OHTIVB-22271-1	GASKET, THROTTLE BODY
OHTIVB-23030-1	LIFTER, VALVE, GRADE 12
OHTIVB-23040-1	LIFTER, VALVE, GRADE 14
OHTIVB-23050-1	LIFTER, VALVE, GRADE 16
OHTIVB-23060-1	LIFTER, VALVE, GRADE 18
OHTIVB-23070-1	LIFTER, VALVE, GRADE 20
OHTIVB-23080-1	LIFTER, VALVE, GRADE 22
OHTIVB-23090-1	LIFTER, VALVE, GRADE 24
OHTIVB-23100-1	LIFTER, VALVE, GRADE 26
OHTIVB-23110-1	LIFTER, VALVE, GRADE 28
OHTIVB-23120-1	LIFTER, VALVE, GRADE 30
OHTIVB-23130-1	LIFTER, VALVE, GRADE 32
OHTIVB-23140-1	LIFTER, VALVE, GRADE 34
OHTIVB-23150-1	LIFTER, VALVE, GRADE 36
OHTIVB-23160-1	LIFTER, VALVE, GRADE 38
OHTIVB-23170-1	LIFTER, VALVE, GRADE 40
OHTIVB-23180-1	LIFTER, VALVE, GRADE 42
OHTIVB-23190-1	LIFTER, VALVE, GRADE 44
OHTIVB-23200-1	LIFTER, VALVE, GRADE 46
OHTIVB-23210-1	LIFTER, VALVE, GRADE 48
OHTIVB-23220-1	LIFTER, VALVE, GRADE 50
OHTIVB-23230-1	LIFTER, VALVE, GRADE 52
OHTIVB-23240-1	LIFTER, VALVE, GRADE 54
OHTIVB-23250-1	LIFTER, VALVE, GRADE 56

OHTIVB-23260-1	LIFTER, VALVE, GRADE 58
OHTIVB-23270-1	LIFTER, VALVE, GRADE 60
OHTIVB-23291-1	INSULATOR, INJECTOR
OHTIVB-25063-1	SPRING, COMPRESSION,
OHTIVB-27014-1	O-RING, FRONT COVER
OHTIVB-28100-1	STARTER, ASSEMBLY (INCLUDES OHTIVB-91612-1 BOLTS AND OHTIVB-08146-1 NUTS)
OHTIVB-29016-1	O-RING, WATER BYPASS PIPE
OHTIVB-30034-1	SPRING, COMPRESSION, SPECIAL TEST, INTAKE, SEQ. IVB,
OHTIVB-31210-1	CLUTCH COVER, ASSY
OHTIVB-31250-1	DISK ASSY., CLUTCH
OHTIVB-47091-1	PAN SUB-ASSY, OIL
OHTIVB-80630-1	BOLT, FLANGE, CHAIN TENSIONER
OHTIVB-80800-1	NUT, FLANGE
OHTIVB-80825-1	BOLT, FLANGE W/ WASHER
OHTIVB-80835-1	BOLT, FLANGE W/ WASHER
OHTIVB-80841-1	NUT, FLANGE
OHTIVB-81020-1	BOLT, FLANGE, ENGINE MOUNTING, FRONT/REAR
OHTIVB-81025-1	BOLT, FLANGE, ENGINE MOUNTING, FRONT/REAR
OHTIVB-82121-1	HARNESS, ENGINE WIRE, 82121-0DD60
OHTIVB-82122-1	WIRE, DYNO, NO.2
OHTIVB-82123-1	STAND WIRING HARNESS SET, INCLUDES 1 EACH ENGINE (OHTIVB-82121-1) & 1 EACH DYNO (OHTIVB-82122-1), MODIFIED, WITH OBDII CONNECTOR, SEQ. IVB
OHTIVB-89465-1	SENSOR, OXYGEN
OHTIVB-89661-1	COMPUTER, ENGINE CONTROL
OHTIVB-90116-1	BOLT, STUD, RH ENGINE MOUNT
OHTIVB-90311-1	SEAL, TYPE T OIL, FRONT COVER
OHTIVB-90363-1	BEARING, RADIAL BALL, CLUTCH
OHTIVB-90460-1	CLAMP, HOSE
OHTIVB-90466-1	CLIP, HOSE, AIR BOX
OHTIVB-90467-1	CLIP, AIR BOX
OHTIVB-90915-1	FILTER, OIL SEQ. IVB
OHTIVB-91612-1	BOLT, W/ WASHER, STARTER
OHTIVB-91619-1	BOLT, W/ WASHER
OHTIVB-A0822-1	BOLT, FLANGE, W/ WASHER
OHT6A-012-5	HOUSING, OBERG ASSEMBLY, 6" WITH 28 MICRON FILTER AND STEEL CHECK VALVE SEAT, 4 PORT
OHT6A-013-3	FILTER, 6, OBERG, 28 MICRON

Appendix

(Non-mandatory Information)

X1. Useful Information

X1.1 General Communications Concerning Sequence IVB Reference Tests, Procedural Questions and Non-Reference Tests:

ASTM Test Monitoring Center
Attention: Administrator
6555 Penn Avenue
Pittsburgh, PA 15206-4489
Telephone: (412) 365-1005

X1.2 Reference Oils and Calibration Oils:

Purchase reference oils and calibration oils by contacting:
ASTM Test Monitoring Center
Attention: Operations Manager
6555 Penn Avenue
Pittsburgh, PA 15206-4489
Telephone: (412) 365-1010

X1.3 Test Engine:

Sequence VIE engines, part 2012 GM (HFV6) OHT6E-001-1
OH Technologies, Inc.
9300 Progress Parkway

P.O. Box 5039
Mentor, OH 44061-5039
Telephone: (440) 354-7007
Fax (440) 354-7080

X1.4 Dynamometer:

A Midwest Model 758 (50-hp) dry gap dynamometer may be ordered from:
Midwest Dynamometer Engineering Company
3100 River Road
River Grove, IL 60171
Telephone: (708) 453-5156
Fax: (708) 453-5171

X1.5 Dynamometer Load Cell:

The recommended load cell is a Lebow Model 3397 which may be ordered from:
Honeywell
2080 Arlingate Lane
Columbus, OH 43228-4112
Telephone: (800) 867-3888

X1.6 Cooling System Pressure Cap:

A satisfactory coolant system pressure cap (100 kPa, normally closed cap) is available through local distributors.

X1.7 Cooling System Pump (P-1):

The specified cooling system pump may be obtained from:
Gould Pumps, Inc.
240 Fall Street
Seneca Falls, NY 13148

X1.8 Coolant Heat Exchanger (HX-1):

ITT (Model 320-20)
ITT Standard
175 Standard Parkway
Buffalo, NY 14227

or

Bell & Gossett (BP 75H-20 or BP 420-20)
Bell & Gossett ITT
8200 N. Austin Avenue
Morton Grove, IL 60053

X1.9 Coolant Orifice Plate (Differential Pressure):

Flowell
8308 South Regency Drive
Tulsa, OK 74131
Telephone: (918) 224-6969

X1.10 Coolant Control Valves (TCV-104, FCV-103 and TCV-101):

Badger Meter, Inc.
P.O. Box 581390
Tulsa, OK 74158
Telephone: (918) 836-8411

X1.11 Differential Pressure Transducer (DPT-1):

The recommended transducers are Viatran Model 274 or Model 374, Validyne Model DP15, and Rosemount model 1151 which may be ordered from:
Viatran Corp.
300 Industrial Drive
Grand Island, NY 14072
Telephone: (716) 773-1700
or
Validyne Engineering Corp.

8626 Wilbur Ave.
Northridge, CA 91324
Telephone: (818) 886-2057
or

Rosemount Inc.
4001 Greenbriar Street 150B
Stafford, Texas 77477
Telephone: 1-800 999-9307

X1.12 Water Pump Plate:

The water pump block off plate OHT6D-005-1 may be purchased from:

OH Technologies, Inc.
9300 Progress Parkway
P.O. Box 5039
Mentor, OH 44061-5039
Telephone: (440) 354-7007
Fax (440) 354-7080

X1.13 Oil Scavenge Pump (P-3):

Houdaille Industries, Inc.
Viking Pump Division
George and Wyeth Street
Cedar Falls, IA 50613
Telephone: (319) 266-1741

X1.14 Thermocouples:

www.omega.com
Telephone: (888) 826-6342

X1.15 Oil Circulation Pump (P-4):

Houdaille Industries, Inc.
Viking Pump Division
George and Wyeth Street
Cedar Falls, IA 50613
Telephone: (319) 266-1741

X1.16 External Oil System Solenoid Valves (FCV-150A, FCV-150C, FCV-150D, FCV-150E and FCV-150F):

Burkert Contromatic Corp.
1091 N. Batavia Street
Orange, CA 92667
Telephone: (714) 744-3230
Fax: (714) 639-4998

X1.17 External Oil System Control Valves (TCV-144 and TCV-145):

Badger Meter, Inc.
P.O. Box 581390
Tulsa, OK 74158
Telephone: (918) 836-8411

X1.18 Oil Heat Exchanger (HX-6):

ITT (Model 310-20):
ITT Standard
175 Standard Parkway
Buffalo, NY 14227

or

Bell & Gossett (Model BP 25-20 or BP 410-020):
Bell & Gossett ITT
8200 N. Austin Avenue
Morton Grove, IL 60053

X1.19 Electric Oil Heater Housing (EH-5):

TEST ENGINEERING, INC. (TEI)

12718 Cimarron Path
San Antonio, TX 78249
Telephone: (210) 690-1958
Fax: (210) 690-1959

X1.20 Oil Filter Housing Assembly OHT6A-012-2 and Filters (Screen) (FIL-2)

Racor 28 micron screen OHT6A-013-3:

OH Technologies, Inc.
9300 Progress Parkway
P.O. Box 5039
Mentor, OH 44061-5039
Telephone: (440) 354-7007
Fax: (440) 354-7080

X1.21 Modified Oil Filter Adapter Plate OHT6D-003-1:

OH Technologies, Inc.
9300 Progress Parkway
P.O. Box 5039
Mentor, OH 44061-5039
Telephone: (440) 354-7007
Fax: (440) 354-7080

X1.22 External Oil System Hose and Quick Disconnect Fittings:

Aeroquip products are available through local distributors or:

Aeroquip Corporation
Industrial Division
1225 W. Main Street
Van Wert, OH 45891
Telephone: (419) 238-1190

X1.23 Modified Oil Pan and Modified Oil Pick-Up Tube OHT6D-001-1:

The oil pan and oil level blocking plate may be purchased from:

OH Technologies, Inc.
9300 Progress Parkway
P.O. Box 5039
Mentor, OH 44061-5039
Telephone: (440) 354-7007
Fax: (440) 354-7080

X1.24 Fuel Flow Measurement Mass Flow Meter:

MicroMotion, Inc.
7070 Winchester Circle
Boulder, CO 80301
Telephone: (303) 530-8400 or (800) 522-6277
Fax: (303) 530-8209

X1.25 AFR Analyzer:

The recommended AFR analyzers are a Horiba MEXA 110, 700, 730 or ECM AFM1000 which may be ordered from:

Horiba Instruments, Inc.
17671 Armstrong
Irvine Industrial Complex
Irvine, CA 92623
Telephone: (714) 250-4811

Or

Engine Control and Monitoring (ECM)
Los Altos, CA
Telephone: (403) 734-3433

X1.26 ECU (Engine Control Unit) Revision 3, OHT6D-012-4:

OH Technologies Inc.
9300 Progress Parkway

P.O. Box 5039
Mentor, OH 44061-5039
Telephone: (440) 354-7007
Fax: (440) 354-7080

X1.27 Engine Wiring Harness Without Interface OHT6D-011-2:

OH Technologies Inc.
9300 Progress Parkway
P.O. Box 5039
Mentor, OH 44061-5039
Telephone: (440) 354-7007
Fax: (440) 354-7080

X1.28 Modified Coolant Inlet:

The coolant inlet may be purchased from:

OH Technologies Inc.
9300 Progress Parkway
P.O. Box 5039
Mentor, OH 44061-5039
Telephone: (440) 354-7007
Fax: (440) 354-7080

X1.29 Organic Solvent (Penmul L460):

Penetone Corporation
74 Hudson Avenue
Tenafly, NJ 07670

X1.30 Degreasing Solvent:

Available from local suppliers.

X1.31 Damper drivelines may be purchased from:

Machine Service Inc.
<http://www.machineservice.com/contact.htm>
American VULKAN Corporation
2525 Dundee Road,
Winterhaven, FL 33884
(863)-324-2424

X1.32 Engine Mounts:

OH Technologies Inc.
9300 Progress Parkway
P.O. Box 5039
Mentor, OH 44061-5039
Telephone: (440) 354-7007
Fax: (440) 354-7080

X1.33 Test Fuel:

Haltermann Products
1201 South Sheldon Road
PO BOX 429
Channelview, TX 77530-0429
Telephone: 281-457-2768

X1.34 Order parts specified as “available from CPD” from:

OH Technologies Inc.
9300 Progress Parkway
P.O. Box 5039
Mentor, OH 44061-5039
Telephone: (440) 354-7007

X1.35 Paxton Fuel Pressure Regulator

Can be obtained from Summit Racing
960 East Glendale Avenue
Sparks, NV 89431
www.summitracing.com

ASTM International takes no position respecting the validity of any patent rights asserted in connection with any item mentioned in this standard. Users of this standard are expressly advised that determination of the validity of any such patent rights, and the risk of infringement of such rights, are entirely their own responsibility. This standard is subject to revision at any time by the responsible technical committee and must be reviewed every five years and if not revised, either reapproved or withdrawn. Your comments are invited either for revision of this standard or for additional standards and should be addressed to ASTM International Headquarters. Your comments will receive careful consideration at a meeting of the responsible technical committee, which you may attend. If you feel that your comments have not received a fair hearing you should make your views known to the ASTM Committee on Standards, at the address shown below.

This standard is copyrighted by ASTM International, 100 Barr Harbor Drive, PO Box C700, West Conshohocken, PA 19428-2959, United States. Individual reprints (single or multiple copies) of this standard may be obtained by contacting ASTM at the above address or at 610-832-9585 (phone), 610-832-9555 (fax), or service@astm.org (e-mail); or through the ASTM website (www.astm.org). Permission rights to photocopy the standard may also be secured from the ASTM website (www.astm.org/COPYRIGHT/).

Draft Sequence IVB Procedure Revision	Revision No.	Revision Date
Initial Draft for Review during 9/7/17 conference call	1.0	9-6-2017
Second Draft that incorporates feedback from 9/7/17 call	2.0	9-8-2017
Incorporates feedback from the 9/26/17 call	3.0	9-26-2017