

# Chrysler IIIH Engine Assembly Manual

**DRAFT**

Revision Release Date:

July 20, 2015

Engineering Contact:

Jeff Betz

313-363-8093

Fiat Chrysler America

This document is to be used as a supplement to the Chrysler Sequence IIIH Engine Oil Certification Test, (ASTM Standard Test Method DXXXX), and is used in conjunction with the Standard Test Method to outline test engine build and assembly instructions.

## Section 0

### Document Index

- 0) Document Index
- 1) Engine Specifications and Fastener Torque
- 2) Precautionary Statements & Cylinder Head Core Preparation
- 3) New Engine Disassembly
- 4) Main Oil Gallery Modifications and Honing
- 5) Post Honing and Special Parts Cleaning
- 6) Cylinder Head Pre-Build Cleaning and Assembly
- 7) Short Block Assembly and General Information
- 8) Long Block Assembly
- 9) Final Dress
- 10) OHT Hardware
- 11) Reagents and Equipment
- 12) Document Update Timeline

# Section 1

## Engine Specifications and Fastener Torque

Revision DRAFT	Chrysler IIIH Engine Specifications	Section	1
July-15		Sheet	1
Description		Specification	

### General Information

Engine Family	60° DOHC V-6 24 Valve	
Compression Ratio	10.2 : 1	
Lead Cylinder	#1 Right Bank	
Firing Order	1-2-3-4-5-6	
	Metric	Standard
Displacement	3.6 Liters	220 Cubic Inches
Bore and Stroke	96.0 x 83.0 mm	3.779 x 3.268 in.

<b>Cylinder Block</b>	Metric	Standard
Cylinder Bore Diameter (Test Target)	96.04	3.781
Cylinder Bore Out-of-Round (Max.)	0.009 mm	0.00035 in.
Cylinder Bore Cylindricity	0.014 mm	0.0006 in.

<b>Pistons</b>	Metric	Standard
Piston Diameter (Metal to Metal)	N/A	N/A
Clearance at Size Location (Metal to Metal)	0.030 - 0.050 mm	0.0012 - 0.002 in.
Clearance at Size Location (Metal to Coating)	0.010 - 0.030 mm	0.0004 - 0.0012 in.
Piston Pin Offset	0.8 mm	0.031 in.
Piston Ring Groove Diameter No. 1	88.24 - 88.44 mm	3.474 - 3.482 in.
Piston Ring Groove Diameter No. 2	86.54 - 86.74 mm	3.407 - 3.415 in.
Piston Ring Groove Diameter No. 3	89.16 - 89.36 mm	3.510 - 3.518 in.
Piston Pin Diameter	21.9985 ± 0.0015 mm	0.86608 ± 0.00006 in.
Piston Pin Clearance in Piston	0.002 - 0.011 mm	0.0001 - 0.0004 in.
Piston Pin Clearance in Rod	0.011 - 0.024 mm	0.0004 - 0.0009 in.

<b>Piston Rings</b>	Metric	Standard
Ring Gap Top (Test Target)	0.635	0.025
Ring Gap Second (Test Target)	0.889	0.035
Ring Gap Oil Control Rails	0.15 - 0.66 mm	0.006 - 0.026 in.

<b>Piston Ring Side Clearance</b>	Metric	Standard
Top	0.025 - 0.083 mm	0.0010 - 0.0033 in.
Second	0.030 - 0.078 mm	0.0012 - 0.0031 in.
Oil Control Assembly	0.007 - 0.173 mm	0.0003 - 0.0068 in.

<b>Piston Ring Width</b>	Metric	Standard
Top	3.00 - 3.20 mm	0.118 - 0.126 in.
Second	3.59 - 3.85 mm	0.141 - 0.152 in.
Oil Control Rails	1.930 - 2.083 mm	0.076 - 0.082 in.

<b>Revision DRAFT</b>	<b>Chrysler IIIH Engine Specifications</b>	<b>Section</b>	<b>1</b>
<b>Jun-15</b>		<b>Sheet</b>	<b>2</b>

Description	Specification	
	Metric	Standard
<b>Connecting Rods</b>		
Bearing Clearance (With Crush)	0.023 - 0.064 mm	0.0009 - 0.0025 in.
Side Clearance	0.070 - 0.370 mm	0.0028 - 0.0146 in.
Piston Pin Bore Diameter	22.016 ± 0.005 mm	0.8668 ± 0.0002 in.
Bearing Bore Out of Round (Max.)	0.008 mm	0.0003 in.

Description	Specification	
	Metric	Standard
<b>Crankshaft Main Bearing Journals</b>		
Diameter	71.996 ± 0.009 mm	2.8345 ± 0.0035 in.
Bearing Clearance	0.024 - 0.050 mm	0.0009 - 0.0020 in.
Out of Round (Max.)	0.005 mm	0.0002 in.
Crankshaft End Play	0.050 - 0.290 mm	0.002 - 0.0114 in.

Description	Specification	
	Metric	Standard
<b>Crankshaft Rod Bearing Journals</b>		
Diameter	59.0 ± 0.009 mm	2.3228 ± 0.0035 in.
Bearing Clearance	0.023 - 0.064 mm	0.0009 - 0.0025 in.
Out of Round (Max.)	0.005 mm	0.0002 in.

Description	Specification	
	Metric	Standard
<b>Camshaft Journal Dia. &amp; Clearance</b>		
Bore Dia. Cam Tower No. 1	32.020 - 32.041 mm	1.2606 - 1.2615 in.
Bore Dia. Cam Towers No. 2, 3, 4	24.020 - 24.041 mm	0.9457 - 0.9465 in.
Journal Dia. No 1	31.976 - 31.995 mm	1.2589 - 1.2596 in.
Journal Dia. No. 2, 3, 4	23.977 - 23.996 mm	0.9440 - 0.9447 in.
Clearance No. 1	0.025 - 0.065 mm	0.001 - 0.0026 in.
Clearance No. 2, 3, 4	0.024 - 0.064 mm	0.0009 - 0.0025 in.
Camshaft End Play	0.075 - 0.251 mm	0.003 - 0.010 in.

Description	Specification	
	Metric	Standard
<b>Cylinder Head</b>		
Compressed Gasket Thickness @ Fire Ring	0.48 - 0.60 mm	0.019 - 0.024 in.
Cylinder Head Deck Flatness	0.09 mm	0.0035 in.
Valve Seat Angle	44.75° ± 0.25° from the valve guide axis	
Intake Valve Seat Width	1.0 - 1.2 mm	0.04 - 0.05 in.
Exhaust Valve Seat Width	1.41 - 1.61 mm	0.055 - 0.063 in.
Valve Guide Bore Diameter	6.00 - 6.02 mm	0.236 - 0.237 in.
Valve Stem to Guide Clearance (Intake)	0.023 - 0.061 mm	0.0009 - 0.0024 in.
Valve Stem to Guide Clearance (Exhaust)	0.030 - 0.068 mm	0.0012 - 0.0027 in.

## Section 2

### Precautionary Statements & Cylinder Head Core Preparation

**Caution:**

The 3.6L Pentastar Engine is NOT A FREE SPIN ENGINE. Care must be exercised during disassembly not to rotate the crankshaft or camshafts once the valvetrain chain assemblies have been altered in any manner.

**Caution:**

Do not lay cylinder heads on gasket sealing surfaces. The design of the Multi-Layer Steel (MLS) cylinder head gasket will not seal properly if there are any imperfections on the cylinder head or engine block. Use only approved plastic type gasket removing tools when cleaning these surfaces.

**Warning:**

Multi-Layer Steel (MLS) head gaskets have very sharp edges that could cause personal injury if not handled carefully.

**Note:**

Multi-Layer Steel gaskets require a scratch free sealing surface.

1. Remove all gasket materials from cylinder head and block using care not to gouge or scratch the aluminum sealing surfaces.
2. Non compressible debris such as oil, coolant, or RTV sealants not removed from bolt holes can cause the aluminum cylinder block to fracture when tightening fasteners.
3. Clean all cylinder head bolt holes in the engine block. Do not use any sealants or adhesives on fasteners, Multi Layer Gaskets, or any sealing surfaces unless specified in this procedure. Surfaces must be debris free and scratch free for proper sealing.

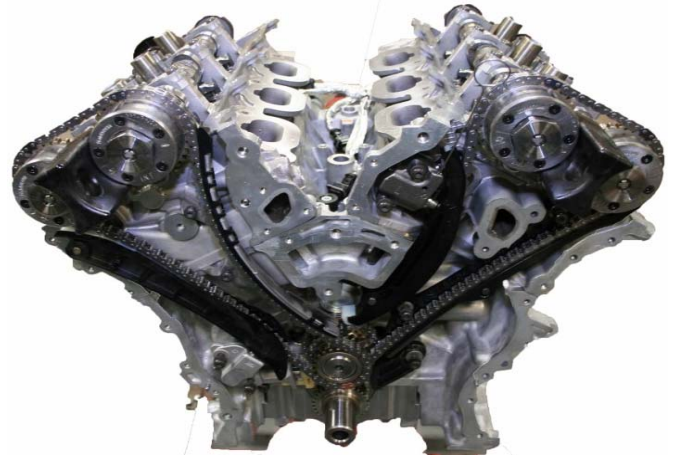
**NOT A FREE SPIN ENGINE**

Valve to Piston interference will occur if not properly disassembled / assembled



Notes:

Revision DRAFT	Cylinder Head Core Preparation	Section	2
July-15		Sheet	2

New engines are ordered through Chrysler MOPAR under special order part number. Engines are preserved under long term packaging. Once received at the test laboratory, they should be disassembled and put into storage for future build. Cylinder heads should be completely disassembled and the valvetrain gear stored for future use.

Bare cylinder heads (Cores) should be sent to IMTS for re-work. Labs must use the IMTS Special Packaging to protect the cores from damage. Packaging contains special cushioning sleeves for both Right and Left cylinder heads.

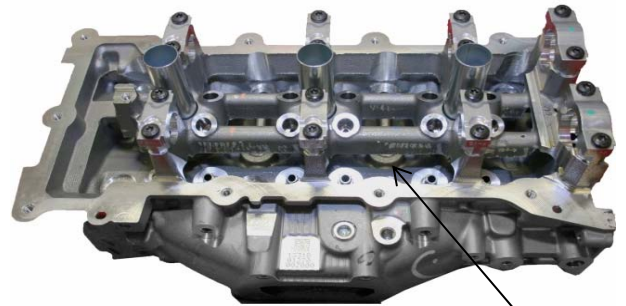

Do not remove oil gallery plugs or freeze plugs

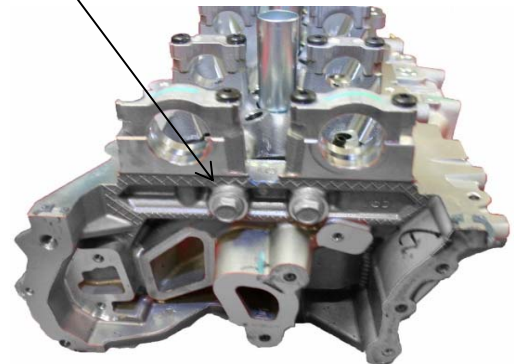

1. Camshaft caps are identified on the sides, "1E-> , 2E->" etc. for exhaust camshafts and "1I-> , 2I->" etc. for intake camshaft caps. Caps must be kept in order.
2. Remove all valvetrain hardware from cylinder heads; camshafts, roller rockers, lash adjusters, valve springs, valve seals, and spark plugs.
3. Keep all camshaft bearing caps in order. Replace after valvetrain hardware removal. Do not use air or battery powered tools to tighten camshaft caps. Use a speed handle to lightly snug fasteners and torque M6 T30 fasteners to 9.5 Nm.
- 4 After removing all valvetrain gear and torquing all camshaft caps in their proper position, install the cylinder head in VCI bag and insert the assembly in the IMTS Packaging with proper inserts, Securely tape package and ship to: IMTS 8460 Ronda Dr. Canton, MI. 48187



Top insert rotates 180° depending which head, left or right is in box.



## Section 3

### New Engine Disassembly

Revision DRAFT	<h1>New Engine Disassembly</h1>	Section	3
Jul-15		Sheet	1

New engines are received from Chrysler as full assemblies. Upon delivery to the build area, they should be disassembled and prepared for test. Cylinder heads should be disassembled and the bare heads need to be packaged for shipment to IMTS for special processing. Packaging from the new cylinder heads to be used for the test should be used for return of new core materials to IMTS.

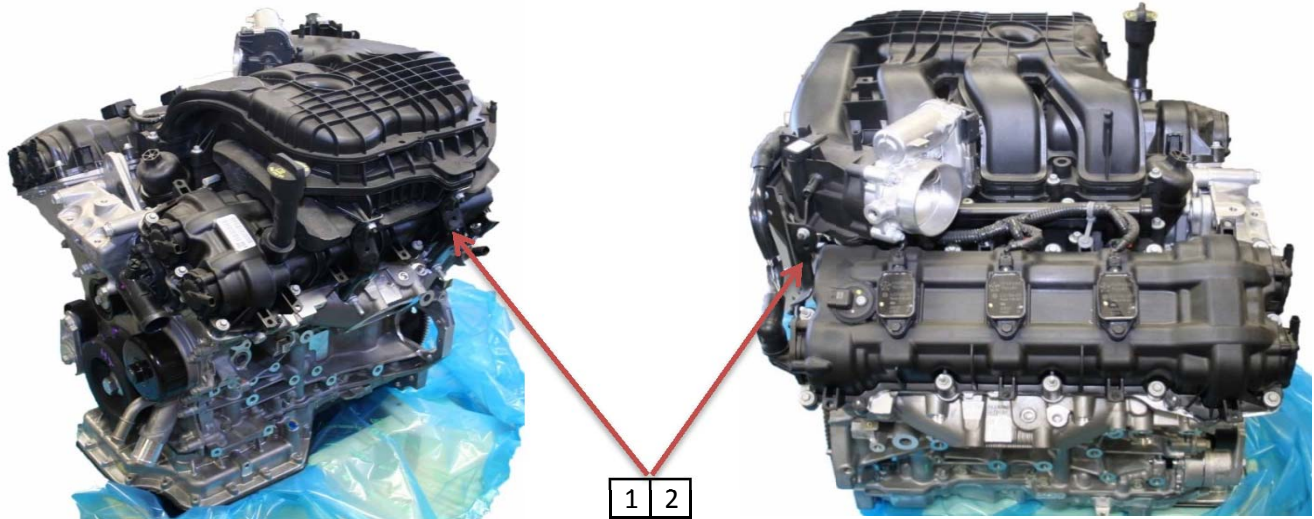

Remove the flywheel and disengage the ignition and fuel injector harness clips on the upper intake manifold brackets (1). Remove both upper intake manifold brackets (2).

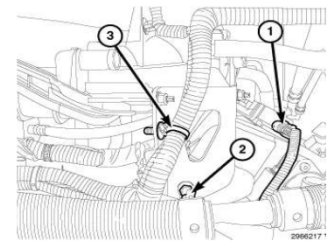
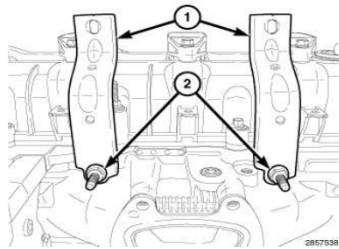

Remove PCV vacuum tube from rocker cover to upper intake manifold. Keep for later use on crankcase vent.

Remove upper intake manifold (2) fasteners (1)

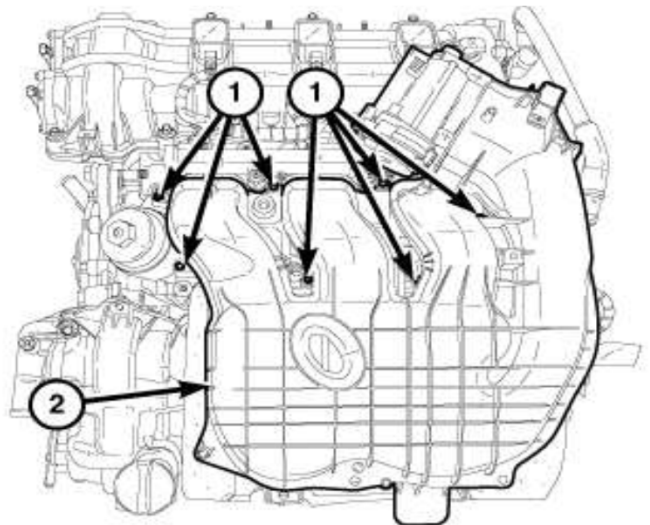
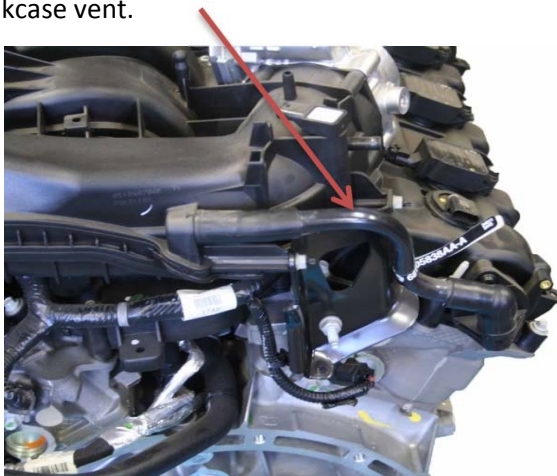

Disconnect all injection harness and ignition harness retainer clips. Disconnect coil pack electrical connectors. Disconnect fuel injector electrical connectors from fuel injectors. Remove harness.

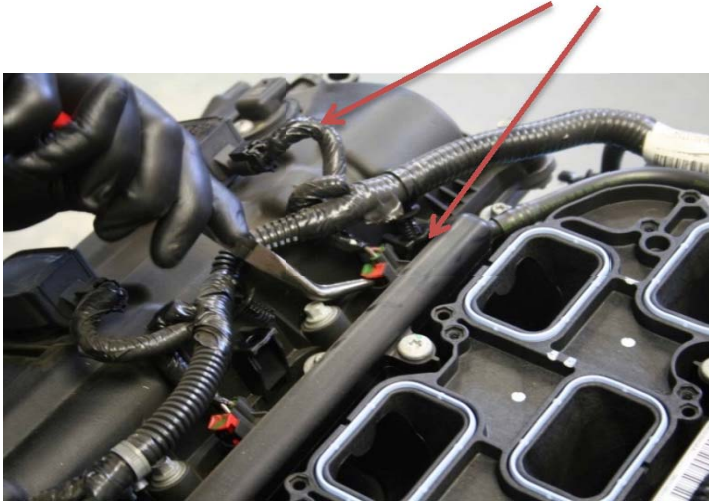

Remove the eight lower intake manifold attaching bolts (1).

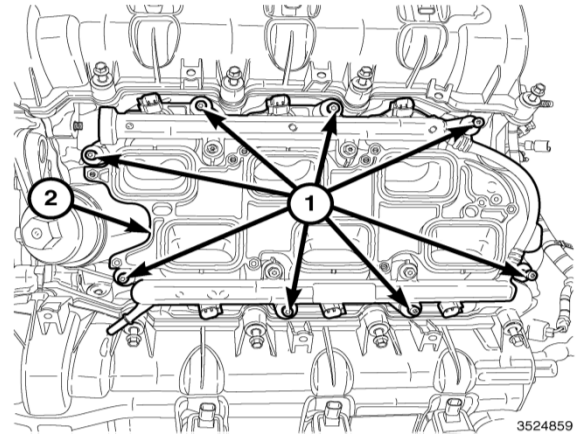

Remove the lower intake manifold (2) with the fuel injectors and fuel rail.



The lower intake manifold is an injection molded nylon composite design. The lower intake seals to the cylinder heads using six individual silicone gaskets. The seven upper intake manifold fasteners thread directly into the composite lower intake manifold and are self-tapping design. The fuel rail is also a composite design. The four fuel rail fasteners thread directly into the lower intake manifold and also are self-tapping design. The fuel rail and fuel injectors must be installed into the lower intake manifold as an assembly. Do not attempt to install the fuel rail when the injectors are in the manifold.

Seal, Lower Intake to Cylinder Head  
051844331AC (Six individual seals)

Seal, Lower Intake to Upper Intake  
05184562AC (Six individual seals)



Install the Driver Side Engine Lifting Bracket 10242-1 (1) on the LH cylinder head with bolts (2) provided with the Engine Lifting Bracket. Tighten the bolts to 21 N·m (15 ft. lbs.).

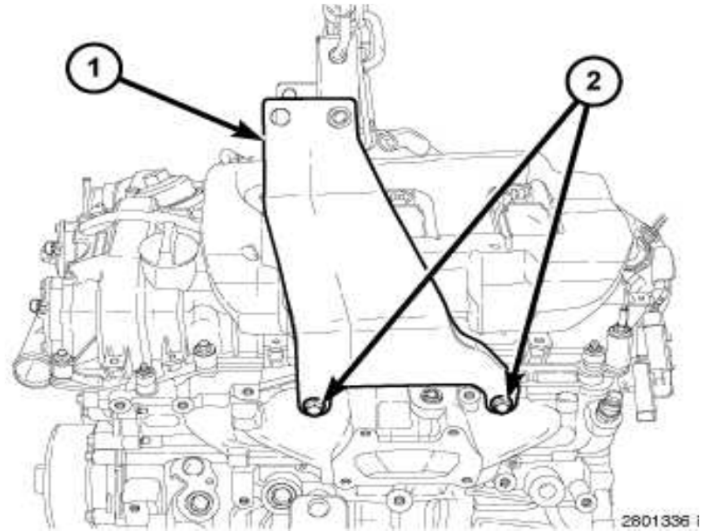

Install the Passenger Side Engine Lifting Bracket 10242-2 (1) on the RH cylinder head with bolts (2) from the Engine Lifting Bracket. Tighten the bolts to 21 N·m (15 ft. lbs.).

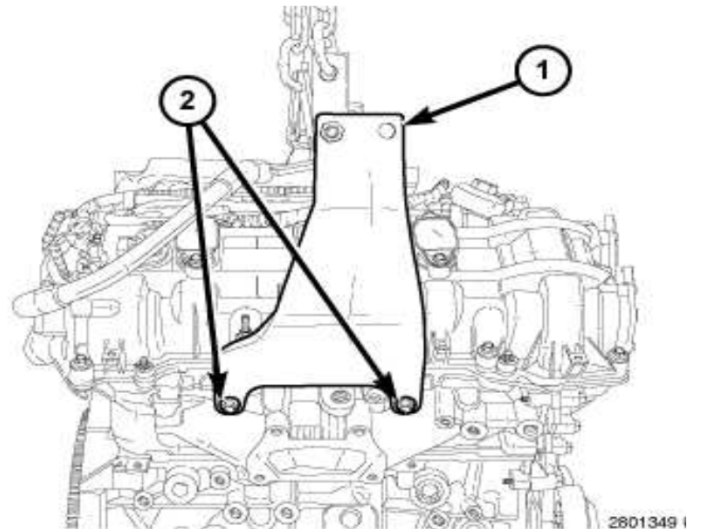

Labs may also chose to fabricate in-house lifting brackets. Care should be taken to ensure the brackets keep all chains and hooks from contacting the camshaft covers. It has been found that plates attached to the exhaust manifold fastener area work well when moving fully assembled engines.

Once positioned on the roll over stand, Remove the oil filter cap and filter cartridge, thereby allowing any oil in the filter housing to drain to the oil pan.

Drain the factory fill engine oil from the oil pan before rotating the engine on the roll over stand.

Remove the front balancer and dip stick tube.

Remove Oil Filter Cap & Cartridge

Remove the Right Engine Mount Bracket.

Remove the idler pulley.

Remove the coolant crossover and thermostat housing.

Remove the coolant pump.

Drain Factory Fill Oil

Remove the serpentine belt tensioner.

Remove the front balancer.

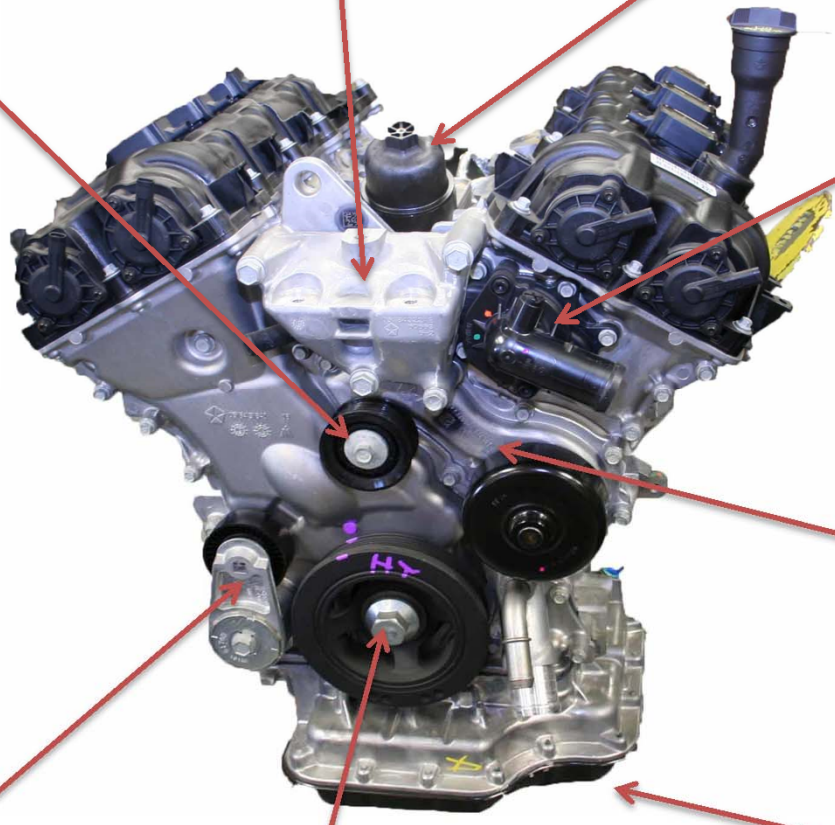

Drain all fluids in the engine, rotating the engine to remove as much oil from the oil pan as possible.

Disconnect all harness retainer clips and connections from the oil filter housing sensors and coolant hose assembly.

Remove the fasteners (2) holding the oil filter housing (1) and oil cooler to the engine valley.

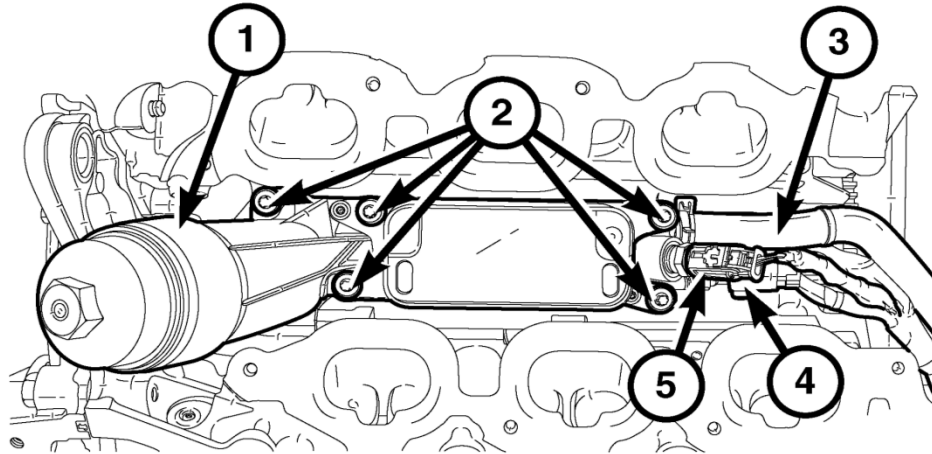

Do not remove the screws (1) and (3) holding the oil cooler to the oil filter housing.

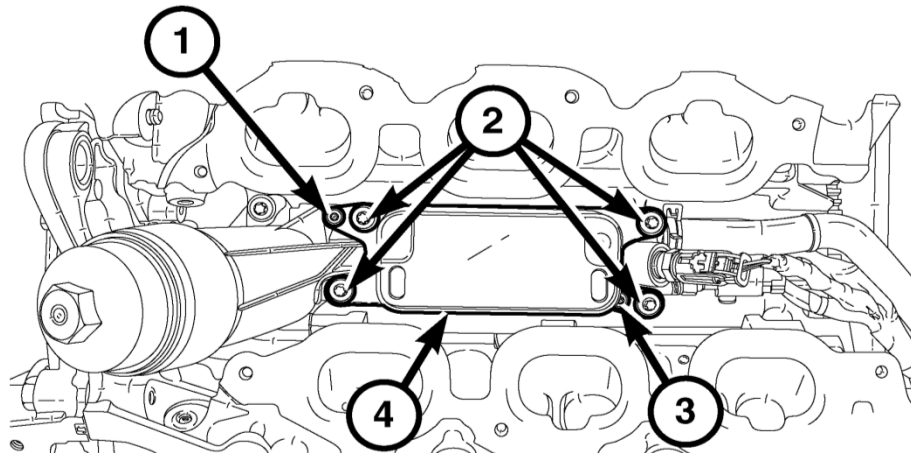

Oil Filter / Cooler Adapter O-ring Kit  
68191356AA  
Contains items (1) & (2)

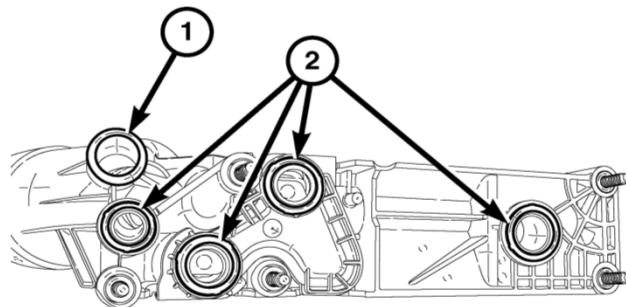

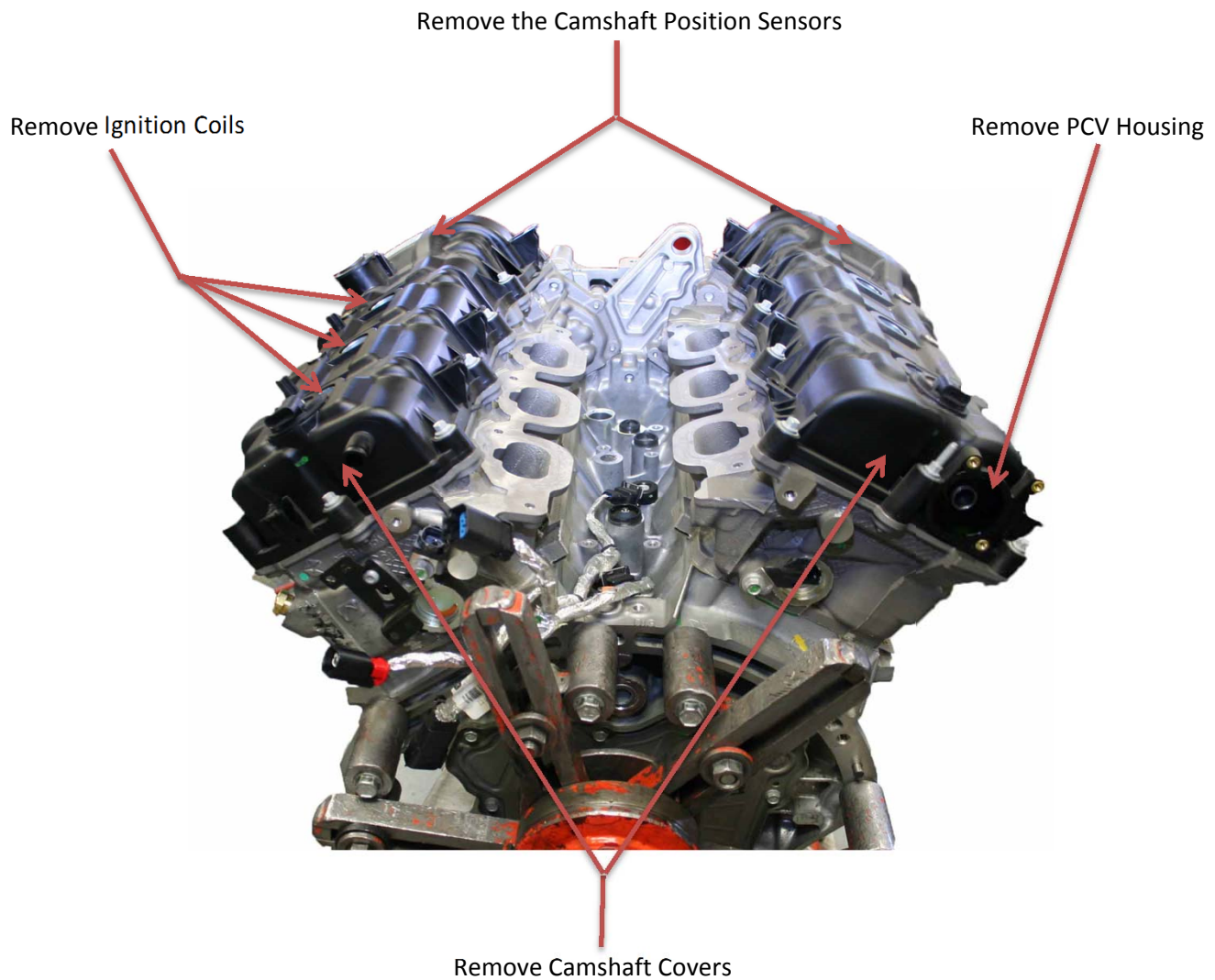
**Part Numbers:**

Gasket, Right Side Cylinder Head Cover 05184595AE

Gasket, Left Side Cylinder Head Cover 05184596AE

Seal, O-ring, Camshaft Phaser Control 05184855AB

Seal, Camshaft Position Sensor 06509450AA

Seal, Tube, Spark Plug Well 05184778AB

Care should be used to prevent damage to the camshaft cover seals at the joint between the front cover and cylinder head by using a sharp putty knife to slice the RTV sealer in these areas as the cover is lifted from the cylinder head.

Remove the lower oil pan fasteners. Use a sharp, rigid putty knife to cut the RTV sealer between the lower and upper oil pans. Remove the lower oil pan.



Remove the upper oil pan fasteners. Use the pry points to break the RTV bond. Apply pressure on the front of the upper oil pan while tapping with a plastic mallet to remove the assembly.



Note: main cap side bolts have also been removed while removing upper oil pan fasteners.



Remove the engine timing chain front cover fasteners.



Using an appropriate pry bar, break the RTV seal at the pry points between the front cover and block. Remove the engine timing chain front cover.

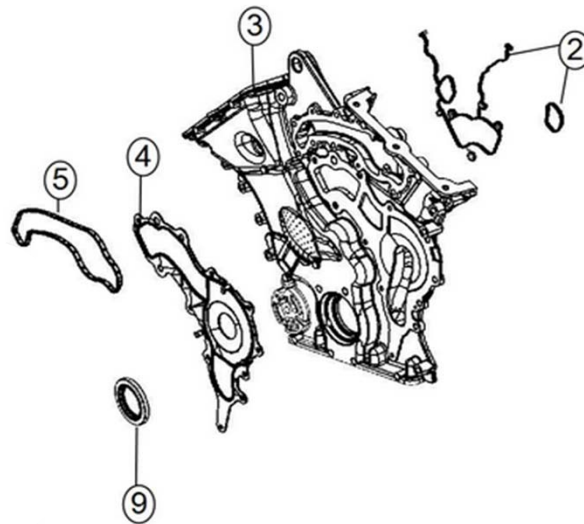

Part Numbers:

- ② Gasket Kit, Chain Case Cover, Crossover Water Outlet 68078604AA
- ④ Gasket, Pump, Water 68087340AA
- ⑤ Gasket, Crossover, Water Outlet 05184454AE
- ⑨ Seal, Crankshaft Oil, Front 68079589AA

**Caution: Camshaft timing alignment is not performed during engine disassembly.**  
**Once the timing chain assemblies are removed, do not rotate the crankshaft until the camshafts are removed.**



Remove all timing chain tensioners, guides, and chains. See Long Block Assembly for Part Numbers.



Remove the camshafts, roller rockers, lash adjusters, cylinder head fasteners, and cylinder heads.  
Re-install the camshaft bushing caps. Remove the valve springs and valves and package the cylinder heads for shipping to IMTS for processing.

Remove the windage tray and main cap side bolts.



Mark the positions on the connecting rods and remove the piston and rod assemblies.



Remove the crankshaft and prepare the engine block for cleaning. Follow procedure for pre stressing and honing the block for test.



## Section 4

### Main Oil Gallery Modifications and Honing

Revision DRAFT	Cylinder Block Main Oil Gallery Thermocouple Installation Tools	Section	4
Jul-15		Sheet	1

The rear main oil gallery is modified to adapt an 1/8 thermocouple just below the mixing point where the oil cooler flow and the oil cooler by-pass flow intermix as it enters the main oil gallery. Special modifications are required to perform these operations and are outlined in this section of the cleaning and pre-hone preparations section of the manual.

**Special tooling fixtures and tools to perform this operation are required and provided through IMTS  
IMTS Chrysler 3.6L Thermocouple Tapping Fixture Assembly 151132-F001**

1. Thermocouple Tapping Fixture 151132-F001 (Main Plate Less Total Assembly Components)

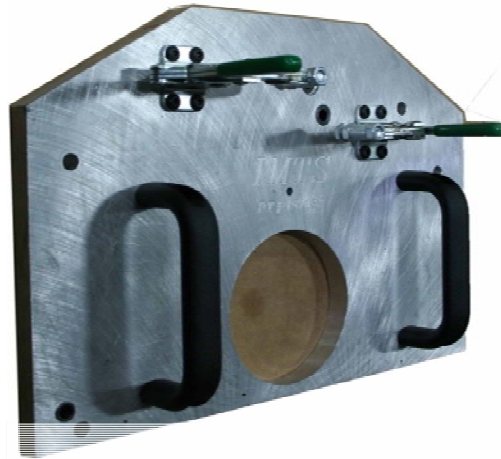

2. Thermocouple Tapping Jig 151132-J001



3. Thermocouple Setting Fixture 151132-F002



4. Thermocouple Tapping Jig Tools and Fasteners

- a. Clearance Drill 151132-T001
- b. Aircraft Drill Special 151132-T002
- c. NPTF Tap Special 151132-T003
- d. Oil Gallery Clean Plug 151132-P003
- e. Fixture Fasteners

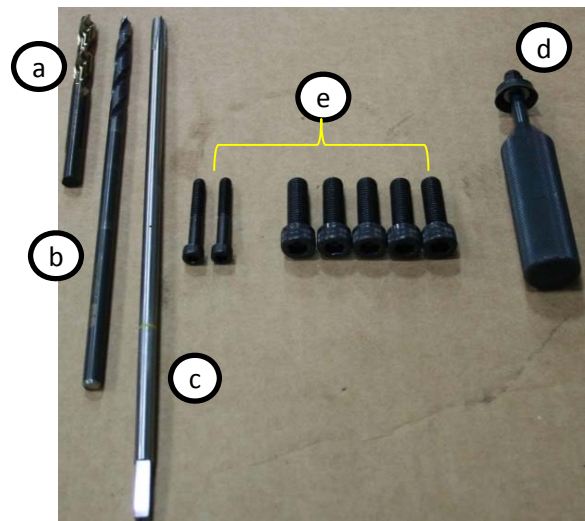

1. Remove the main oil gallery access plug from the right side of the engine. Remove the Crankshaft Sensor from the right side of the engine.

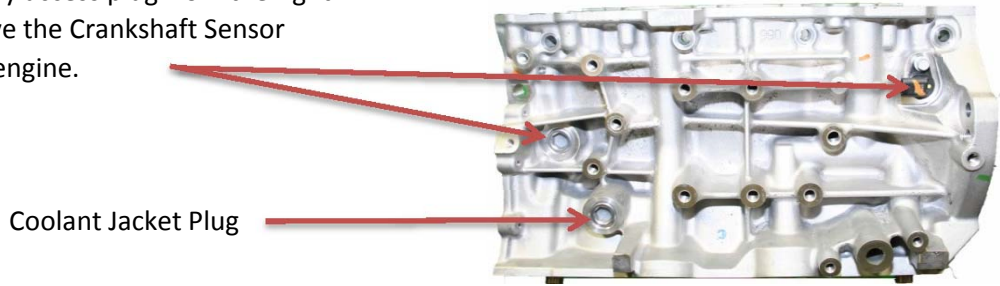

2. Remove the main oil gallery access plug from the left side of the engine.

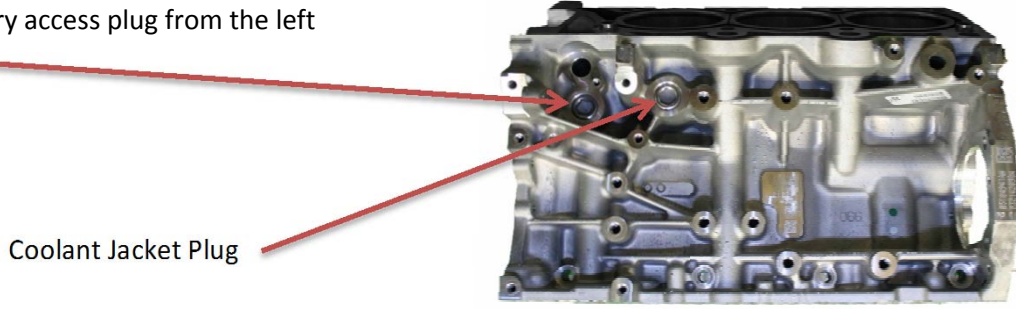

3. Remove the cup plug from the front main oil gallery. Plug, Front, Cup, Oil Gallery 04556020AB

**Do not remove the timing chain idler gear pressed fit shaft**

**Do not reuse cup plug, replace with new plug each test.**

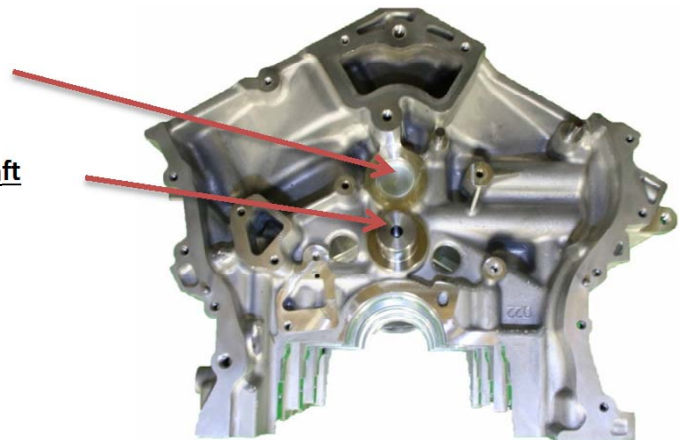

4. Remove the rear main oil gallery plug.



5. Remove all three piston cooling jet assemblies from the main oil gallery.

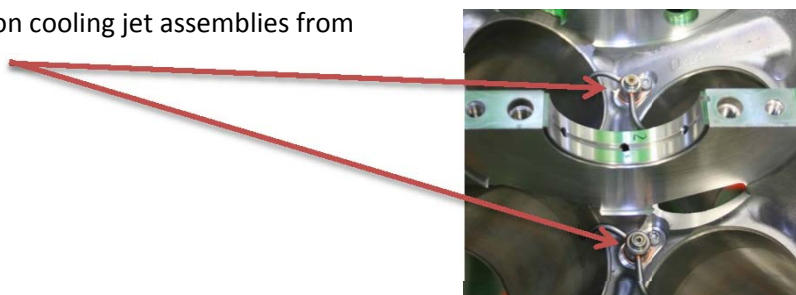

Revision DRAFT	Cylinder Block Main Oil Gallery Thermocouple Modification	Section	4
Jul-15		Sheet	3

6. Attach the main tooling fixture plate to the rear of the engine aligning the plate over the transmission dowel pins with five allen hex fasteners.



7. Install the oil gallery Clean Plug Assembly 151132-P003 using EF-411 or an assembly type grease on the leather seal to aid in preventing machining debris from entering the lower main oil gallery. Gently rock the plug assembly back and forth installing the tool until it bottoms in the oil gallery.



8. Using a 1/2 inch Drill Motor with the Clearance Drill 151132-T001, drill a clearance hole through the rear China Wall of the engine block using the hardened bushing to guide the drill bit through the China Wall.



Revision DRAFT	Cylinder Block Main Oil Gallery Thermocouple Modification	Section	4
Jul-15		Sheet	4

9. Install the main oil gallery thermocouple drilling and tapping fixture 151132-J001 to the rear of the engine. Note the round and triangular alignment pin combination on the fixture for ease of installation alignment. Secure the 151132-J001 fixture using the toggle clamps and allen hex head fasteners.

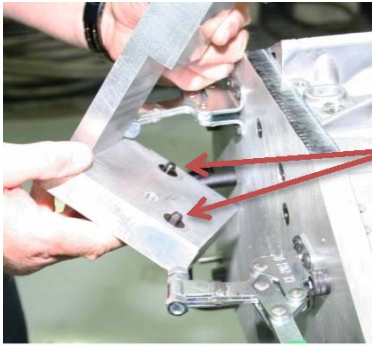

Fasteners  
(Snug Only)

Alignment pins

Toggle Clamps

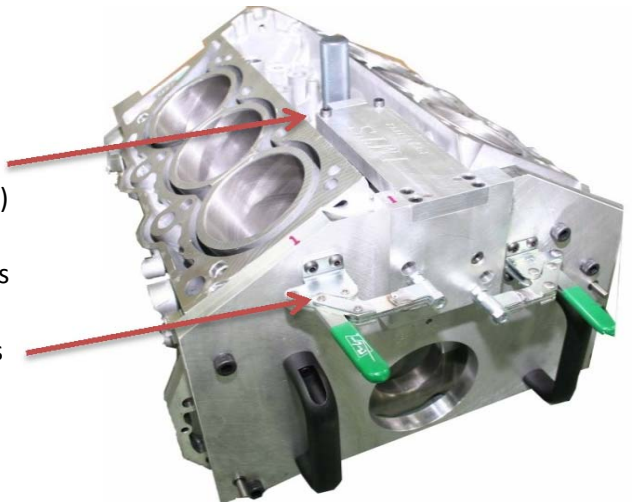

10. Using a 1/2" drill motor with the Special Tip Aircraft Drill 151132-T002, drill through the main oil gallery until the tip of the drill breaks through the inside.

**Note special cut tip on tool 151132-T002**

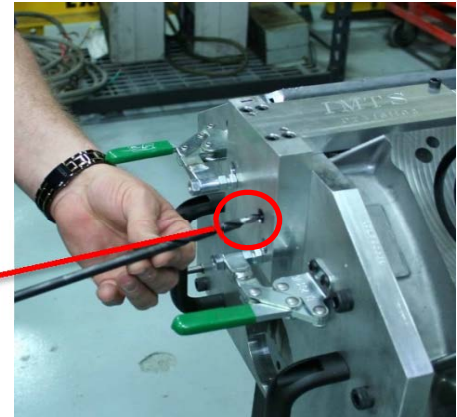

11. Using an appropriately sized Tee Handle with the special length tapping tool 151132-T003 1/16" NPTF Tap, thread the drilled hole in the main oil gallery until the Yellow Ring on 151132-T003 meets the hardened bushing guide on the tapping fixture 151132-J001.

**Note, the use of a tapping lubricant or grease to hold machining debris is recommended.**



12. After threading the main oil gallery, carefully remove all fixture tooling, leaving the Clean Plug Assembly in the main gallery.

**Using preferred laboratory cleaning practice, clean the threads and any machining debris from the main oil gallery. Carefully remove the Clean Plug Assembly and inspect the threaded hole for any burrs or sharp edges on the inside of the main oil gallery.**





Revision DRAFT	<b>Cylinder Block Cleaning Pre Hone Prep</b>	Section	4
Jul-15		Sheet	5

1 After disassembly and modification of the main oil gallery, technicians should carefully clean all RTV from mating surfaces using care to avoid scratching or gouging any mating surfaces. Spray degreasing solvent through all oil gallery passages from the underside through the piston cooling jet access holes to clean any debris from galleries.

**Caution:**

Technicians should exercise extreme caution while cleaning mating surfaces of the engine block. Use only plastic type non marring scrapers for removal of RTV and other debris from mating surfaces. Visual imperfections on the cylinder deck and other gasket sealing areas may remain even after removing RTV.

2 If desired, chase all threaded bolt holes for the cylinder head bolt holes and the main cap bolt holes using cleaning thread chase taps. Avoid using thread cutting type taps to clean threads. Thread cleaning taps are available through sources such as ARP, Snap-on, or Mac Tools for SAE and Metric thread sizes.

**Caution:**

Non compressible debris such as oil, coolant, or RTV sealants not removed from bolt holes can cause the aluminum cylinder block to fracture when tightening fasteners.

3 Clean the engine block prior to honing using either of the following methods;

- a. Clean in the spray booth using degreasing solvent followed by a 50/50 solution of EF-411 and Degreasing Solvent followed by air dry using clean dry compressed shop air.
- b. Clean using the Ultra Sonic Cleaner following the manufacturers recommendations followed by a water rinse and spray with a 50/50 solution of EF-411 and Degreasing Solvent followed by air dry using clean compressed air.

4 Clean and inspect the cylinder head fasteners from the New Engine Disassembly.

5 Lightly oil the cylinder head fasteners with EF-411 and allow to drain all excess oil from the threads using clean Teri towels before installation of cylinder torque plates.

6 Clean and lightly oil the main cap fasteners and side bolts using EF-411 allowing all excess oil to drain from the threads using clean Teri towels.

7 Cylinder head gaskets are Multi-Layer Steel gaskets. The cylinder head gaskets removed during the New Engine disassembly can be re-used with the BHJ Torque Plates and spacers used to position the fasteners at the correct bolt drop in the cylinder block.

8 A good practice for build technicians is to ensure there is no oil or debris in the blind threaded bolt holes before assembling the main caps or cylinder block torque plates using compressed air or blotting with absorbent materials.

Revision DRAFT	Cylinder Block Honing Prep Main Cap Installation	Section	4
Jul-15		Sheet	6

- 1 Install the main caps using both the inner and outer main cap fasteners.  
 Note: The outer main cap fasteners are used without the windage tray in place for the honing operation.
- 2 Use a socket with a speed handle in a criss cross pattern working from the center out to seat the main caps. Start with the inner fasteners and then the outer fasteners. See View A. (Positions 1 through 16)
- 3 After seating the main caps, loosen all 16 main cap fasteners 1/4 turn.
- 4 Torque the inner main cap fasteners to 20 N·m (15 ft. lbs.) plus 90° following the inside out pattern shown in View A. Fastener positions ① through ⑧.
- 5 Torque the outer main cap fasteners (without the windage tray) to 21 N·m (16 ft. lbs.) plus 90° following View A. Fastener positions ⑨ through ⑯.
- 6 Install the eight main bearing cap tie bolts (side bolts) and tighten the fasteners to 28 N·m (21 ft. lbs.) using the sequence shown in View A. ① through ⑧

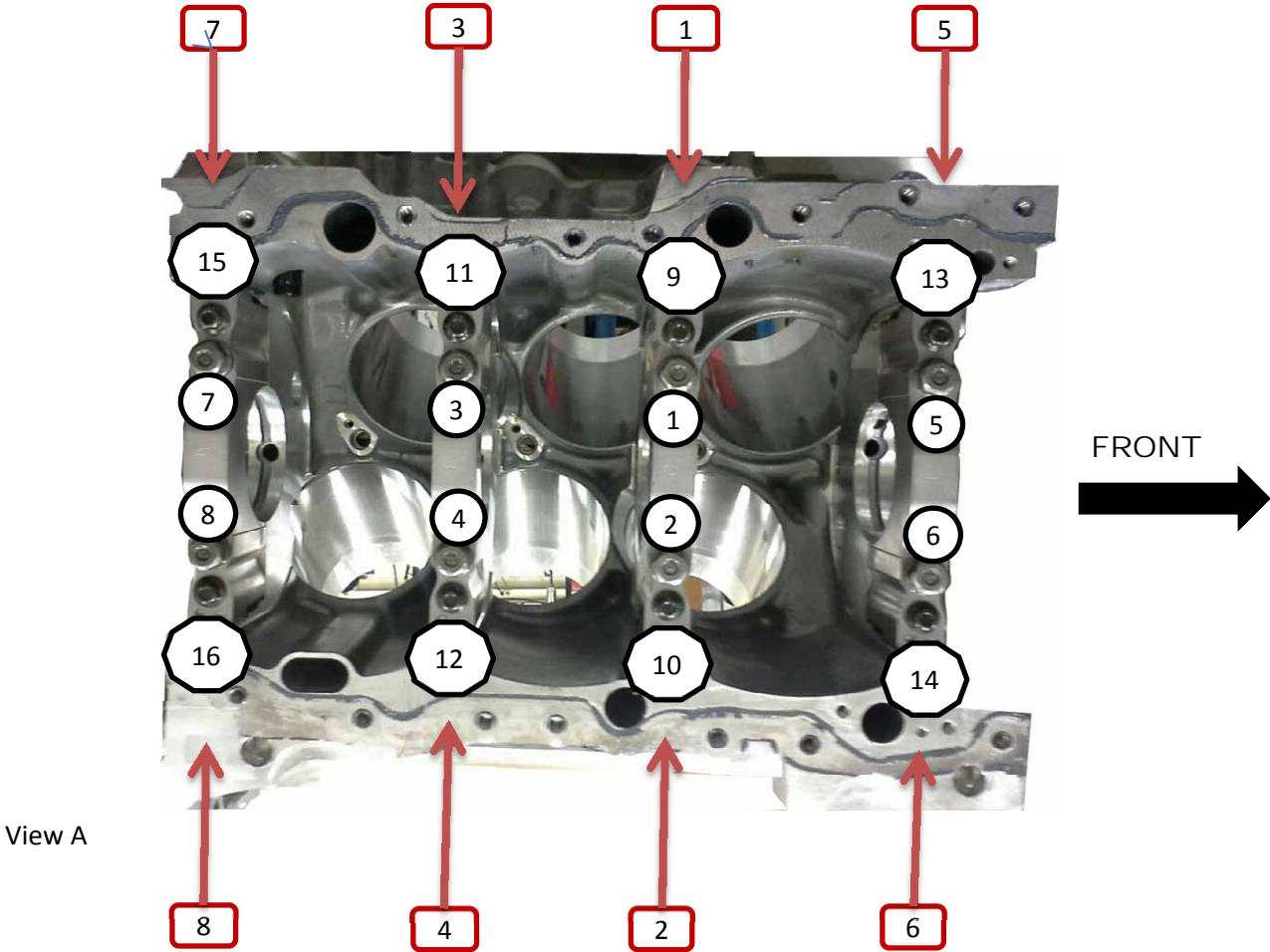

**All operators should become familiar with the Sunnen SV-10 Honer Operator Manual, safety precautions, set up procedures, and operations of the SV-10 Honer before honing engine blocks.**

**Required Parts and Equipment**

1. Sunnen SV-10 Honing Machine
2. Sunnen Honing Oil SHO965055 (55 gal.) / SHO965005 (5 gal.)
3. Course Diamond Stones: Sunnen DHH6GMH85
4. Plateau Brush: Sunnen DHHB6534 (DHHB7534 is an adequate substitute)

**Machine Setup**

Place the block in the SV-10 honing machine with the front of the block facing left.  
 Set the stroke length before installing the torque plates to 3.0 " on the inch scale or 75 mm on the metric scale.  
 Set the Ratchet Feed setting to 1.

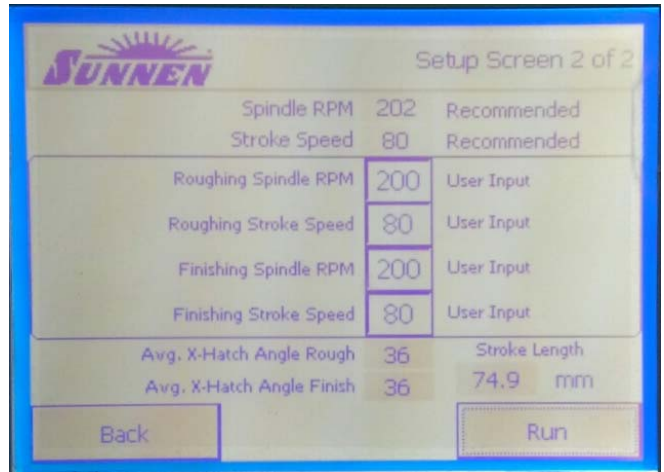
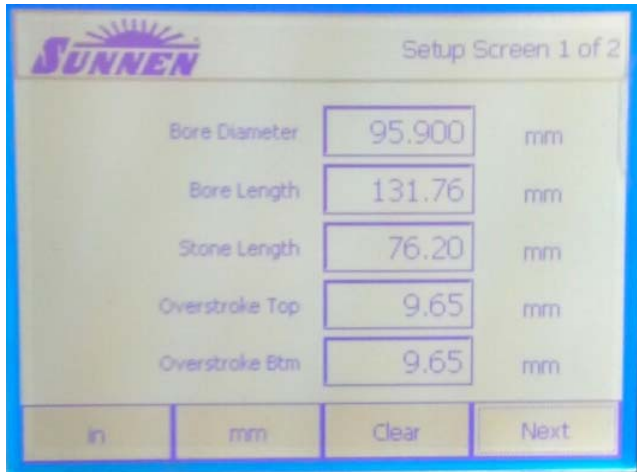

Using the automated setup screens input the following parameters;

Screen 1	Bore Diameter	95.90mm
	Bore Length	131.76mm
	Stone Length	76.20mm
	Over stroke Top	9.65mm
	Over stroke Bottom	9.65mm
Screen 2	Roughing Spindle Speed RPM	200
	Roughing Stroke Speed	80
	Finishing Spindle Speed RPM	200
	Finishing Stroke Speed	80

These user input values should yield an average X-hatch angle of 36° and a stroke length of 74.9 mm.

Revision DRAFT	<b>Cylinder Block Honing Prep Torque Plate Installation</b>	Section	4
Jul-15		Sheet	8

1 Install the engine block in the honer and tighten the block in place using the honing bar through the main caps. (Refer to Section 4 Sheet 7 if the honer was not pre set for the proper engine block).

**Caution:**

Non compressible debris such as oil, coolant, RTV sealants or honing fluids not removed from bolt holes can cause the aluminum cylinder block to fracture when tightening fasteners. If the torque plates are being installed while the block is in the honer, operators must use caution to ensure there is no honing fluid in the threaded bores for the cylinder head fasteners.

2 With the front of the block facing to the left, and the engine angled so the left side deck is up, install the left side cylinder head gasket and BHJ Torque Plate identification MP-3.6PSV6-R-AL-T-DID. Install the fasteners with the BHJ Spacers and tighten by hand following the proper torqueing procedure.

3 Rotate the engine so the right side deck is angled up and install the cylinder head gasket, torque plate, and fasteners with spacers as outlined in line item 2.

5 Torque the cylinder head fasteners following the inside out pattern identified in View B following the process outlined in line items a. through d. below

- a. All fasteners to 30 N·m
- b. All fasteners to 45 N·m
- c. All fasteners plus 70° (First Pass)
- d. All fasteners plus 70° (Second Pass)

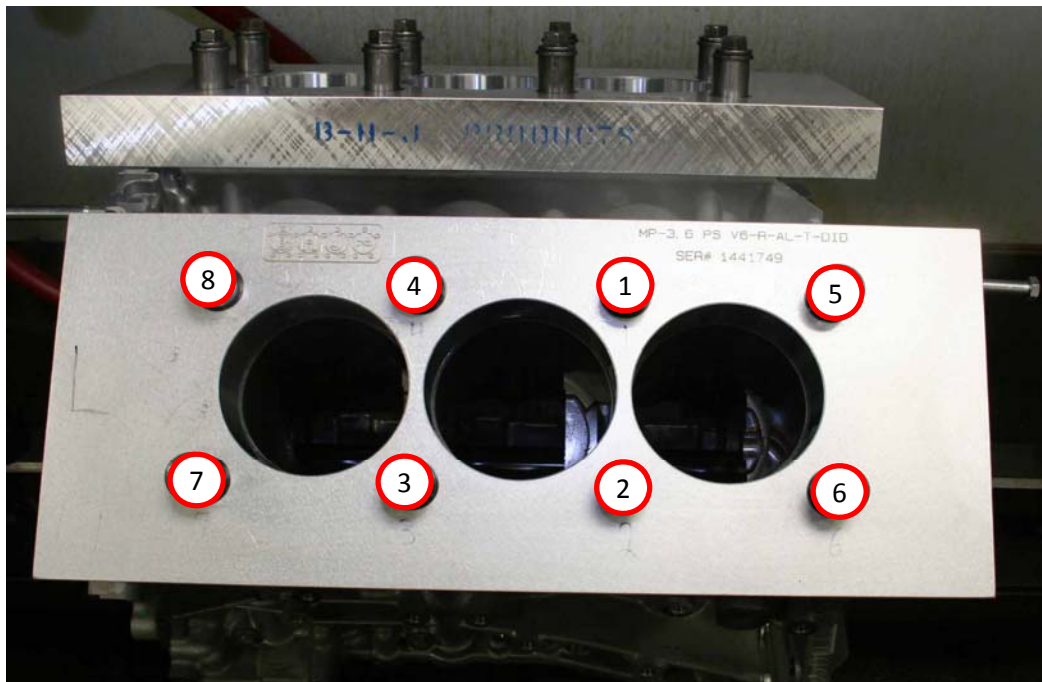

View B

With the honing fluid flow rate set at 7 L/m and the Auto Dwell setting On.

Use the course hone speed setting with the DHH6GMH85 Diamond Stones at a setting of 30 to 40 units load to hone each cylinder to a target bore size of 96.035 to 96.045mm diameter.

Note:

Care should be exercised to prevent the machine from auto dwelling as it gets close to the target bore diameter.

Once the target diameter has been achieved, switch to the DHHB6534 Brush Hone and using the course hone speed run the honer maintaining 10 to 15 units load for 6 to 10 strokes to achieve the desired surface finish parameters.

### **Measurements**

Bore Size:

Record bore measurements in the transverse and longitudinal directions at 0.5, 2.0, and 3.5 inch positions below the cylinder block deck surface. Maximum out-of-round specification is 0.009mm and maximum taper is 0.015mm.

Record individual cylinder surface finish parameters according to instructions on Section 4 Sheet 10 using the Mitutoyo Surf Analyzer SJ-410 shown below.



**All operators should become familiar with the Mitutoyo Surf Analyzer Model SJ-410 Operator Manual, set up procedures, proper settings, and operations of the SJ-410 Surf Analyzer before use.**

## Setup and measurement procedure

1 Stylus selection 12AAB409 with a 5 micron tip. Skid Yes

2 Evaluation conditions:

Standard: ISO1997

Profile: R

Filter: Gaussian

$\lambda f$ : 2.5

$\lambda c$ : 0.8 mm

$\lambda s$ : 2.5 $\mu$ m

M-Speed: 0.5

Range: 800

N: 5

pre/post: on

del. Wave: off

prof.comp.: off

mean line: off

3 Parameters to set for recording are: Ra, Rz, Rv, Rk, Rpk, Rvk, Mr1, Mr2

4 Using the Mitutoyo Surf analyzer leveled with the cylinder, record the surface finish parameters at 2.0 inches and 1.0 inches below the cylinder block deck surface. Average the readings between each cylinder and record the values for each cylinder.

Target Specifications	
Rk	0.75 to 1.5 $\mu$ m
Rpk	0.13 to 0.80 $\mu$ m
Rvk	1.00 to 2.5 $\mu$ m
Rz	3.50 to 6.00 $\mu$ m
Mr2	70% Minimum

Upon completion of all surface finish measurements, record the data in the appropriate forms and proceed to Section 4 Sheet 11 to measure and record the piston ring gaps.

Revision DRAFT	Piston Ring Gap Measurements	Section	4
Jul-15		Sheet	11

Piston Ring gaps are measured with the BHJ Torque Plates installed on the block. After the honing process is complete, the block should be set aside to cool to room temperature. Lab technicians should use a piston ring positioning tool to properly locate each top and second piston ring in each respective bore ~1.0 inch from the deck of the block as indicated in Section 7 Sheet 4. (See Excerpt Below) Record the piston ring gaps on the appropriate engine build data form and keep the rings in their respective order for final engine assembly.



**Excerpt from Section 7 Sheet 4**

<p><b>Piston Ring Gap Measurement:</b>          Position the top and second piston rings ~ 1 inch down from the top of the bore. Using a Starrett Taper Gage Model 270, measure the gap and record the pre-test measurement on the appropriate engine build data form. <b><u>Note: Labs perform all ring gap measurements with the BHJ Torque Plates still installed on the engine. This view is for illustration only.</u></b></p>	
---	--

Upon completion of all piston ring gap measurements, record the data in the appropriate forms and follow standard laboratory cleaning procedures for cleaning the block using the Ultra Sonic Cleaner following the manufacturer recommendations followed by a water rinse and spray with a 50/50 solution of degreasing solvent and air drying.

## Section 5

### Post Honing and Special Parts Cleaning



Revision DRAFT	Post Honing and Special Parts Cleaning	Section	5
Jul-15		Sheet	1

### Cleaning Reagents

1. Ultra Sonic Cleaning Solution;
  - a. Ultrasonic Solution 7 @ 4.48 oz. / Gallon Water
  - b. Ultrasonic Solution B @ 0.38 oz. / Gallon Water
  
2. Engine Degreasing Solvent;
 

Use only mineral spirits meeting the specifications for volume fraction of aromatics 0 % to 2 %, flash point 61 °C minimum, and color not darker than +25 on Saybolt Scale or 25 on Pt-Co Scale from Specification D235 for the Type II, Class C mineral spirits. (Warning – Combustible. Health hazard.)
  
3. 50/50 Engine Degreasing Solvent and Engine Assembly Fluid EF-411
  - a. 50% Engine Degreasing Solvent (See Item #2. Above)
  - b. 50% Engine Assembly Fluid, EF-411 (A non-metals additized assembly fluid)

### Description

#### Ultra Sonic Cleaner:

The Ultra Sonic Cleaner must be operated according to the recommended cleaning procedures and guidelines provided from the manufacturer. The bath should be changed and the unit cleaned after every 25 hours of use.

#### Operating Guidelines:

- a. Solution Temperature of 150°F ± 10°F.
- b. Parts should be cleaned for 60 minutes ± 15 minutes depending on level of cleanliness.
- c. Upon removal of parts, they should be water rinsed using hot water at a temperature which does not promote oxidation flash-over on the surface of the parts being cleaned.
- d. Parts must be sprayed using a 50/50 solution of Engine Degreasing Solvent and EF-411 (See line item #3 above).

#### Engine Degreasing Solvent:

Solvent must be single pass, used in a well ventilated area meeting Occupational Safety and Health Administration (OSHA) Safety Guidelines.

#### 50/50 Engine Degreasing Solvent and Engine Assembly Fluid EF-411:

Solvent and EF-411 must be single pass, used in a well ventilated area meeting OSHA Safety Guidelines. Parts should be air dried using clean dry shop air to remove excess solution after application.

If additional cleaning reagents are used for any reason, the part must be cleaned using Engine Degreasing Solvent followed by a 50/50 mix of Engine Degreasing Solvent and EF-411 following the aforementioned guidelines before installation on a IIH Test Engine.

Revision DRAFT	Post Honing and Special Parts Cleaning	Section	5
Jul-15		Sheet	2

### Engine Oil Pump

The Engine Oil Pump, when removed from the New Production Engine contains Factory Fill Engine Oil.

The engine oil pump must be cleaned using Degreasing Solvent followed by a 50/50 solution of Engine Degreasing Solvent and EF-411 followed by air drying.

The intent of this manual is to explain the areas of concern during the oil pump cleaning process.

Labs are free to use internally fabricated automated type cleaning fixtures if desired, however;

**Caution needs to be exercised during cleaning to avoid dry spinning of the oil pump gear assembly.**

Labs may decide to open certain sections of the assembly, however, technicians should be extremely careful to avoid removal of the pressure balance spring and rotary section, including vanes and seals during any cleaning procedure.

Labs can use multiple methods to spray the degreasing solvent through the passages while rotating the pump drive gear to cycle the cleaning solution through the internals of the pump.

The Oil Pump must be clear of any excess cleaning solution and/or 50/50 Engine Degreasing Solvent and EF-411 before installing on a new test engine.



Engine Oil Pump as removed from the New Production Engine

The following is not a procedural required disassembly of the engine oil pump. This information is supplied for a better understand of the areas needing cleaning.



Pickup Tube, Suction Side of Pump

Oil pressure control feed back chamber .....Inlet port

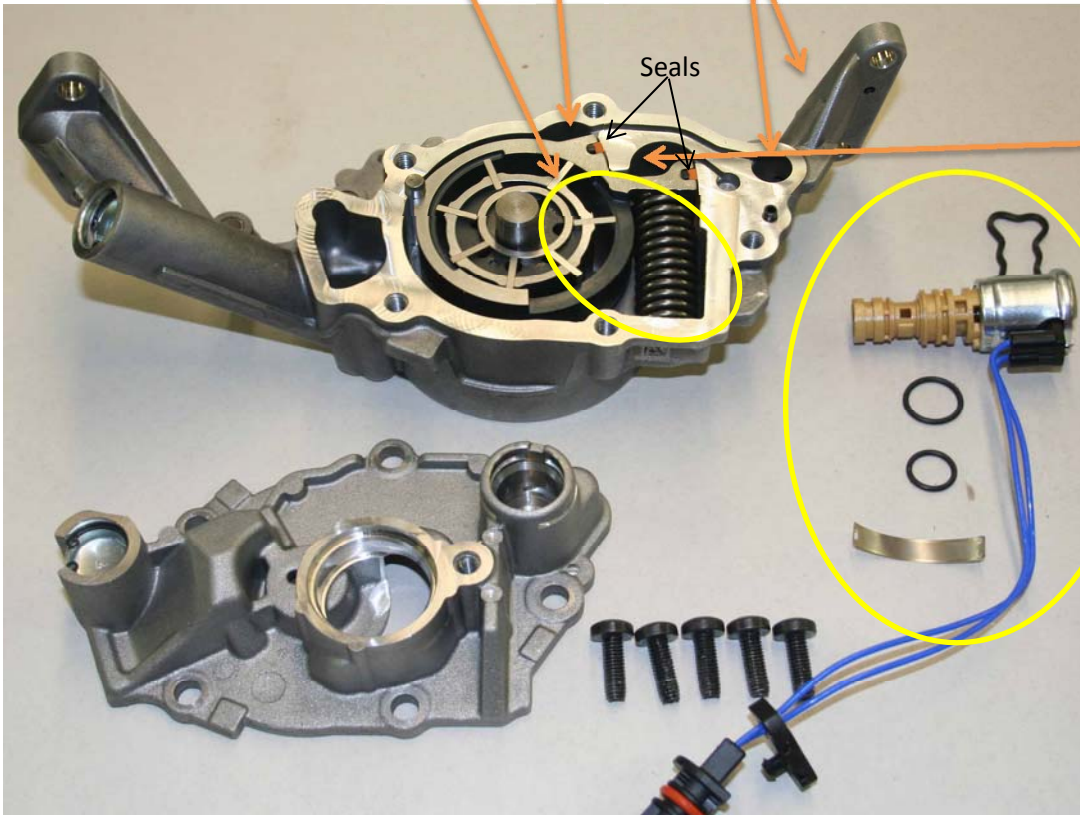

Seals

Solenoid controlled  
Low Pressure  
Chamber

Low Pressure  
Solenoid with  
O-rings, screen  
and retainer clip

Notes:

## Additional pump information

If this pin comes loose when removing the pump cover, the complete inside of the pump needs to be re-assembled. Care needs to be exercised to ensure it remains properly seated in the pump housing.



If the pressure spring is removed, a suitable means of re-installing the spring is to use a quality Wood Working Clamp assembly to compress the spring for re-assembly.

1. Square the clamp jaws with the spring protruding  $\sim 1/3$  of its diameter outside the jaws.
2. Tighten the spring until it fits inside the space between the pump housing and the variable rotor housing.
3. Holding the spring in place with the flats of the jaws square to the housing, loosen the jaws until the spring touches both housings with a light amount of pressure.
4. Holding the Wood Working Clamp firmly in position, use a suitable mallet handle to firmly position the spring in the pump housing assembly.

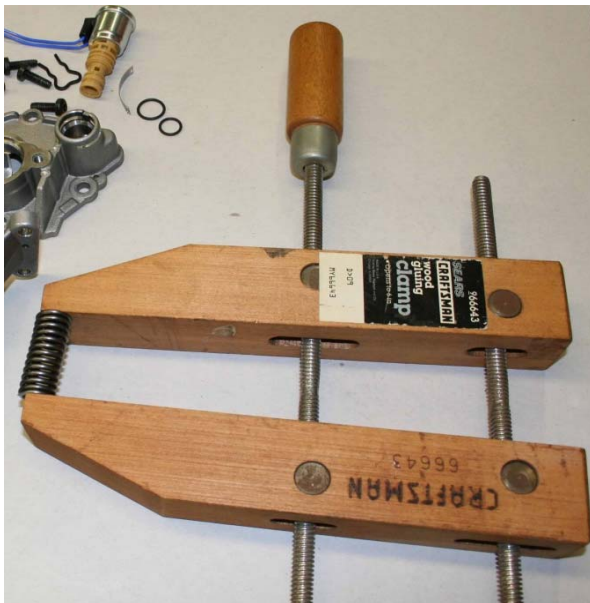

Revision DRAFT	Post Honing and Special Parts Cleaning	Section	5
Jul-15		Sheet	5

### Camshaft Phasers

The Camshaft Phasers are fixed at 110° on the Intake and 112° on the Exhaust

The phasers may be used multiple times and build technicians need to disassemble the phasers and clean the post-test oil from the phasers before each test.

1. Disassemble the Phasers keeping the components together during the cleaning process.



2. Do not separate the inner and outer housing assembly.



3. Clean the phasers using the Ultra Sonic Cleaner or Engine Degreasing Solvent followed by a 50/50 solution of Engine Degreasing Solvent and EF-411 followed by air drying.
4. Assemble each phaser aligning the pins, gears and cover plates for each unit accordingly.

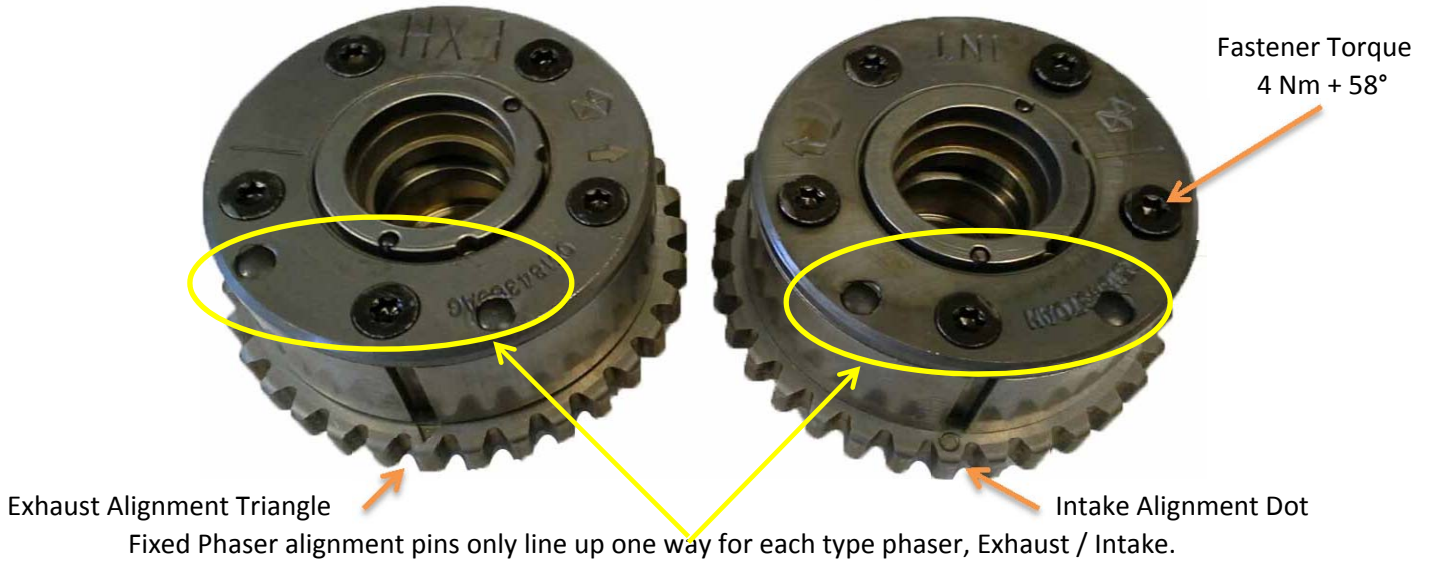

### Oil Filter and Cooler Cleaning

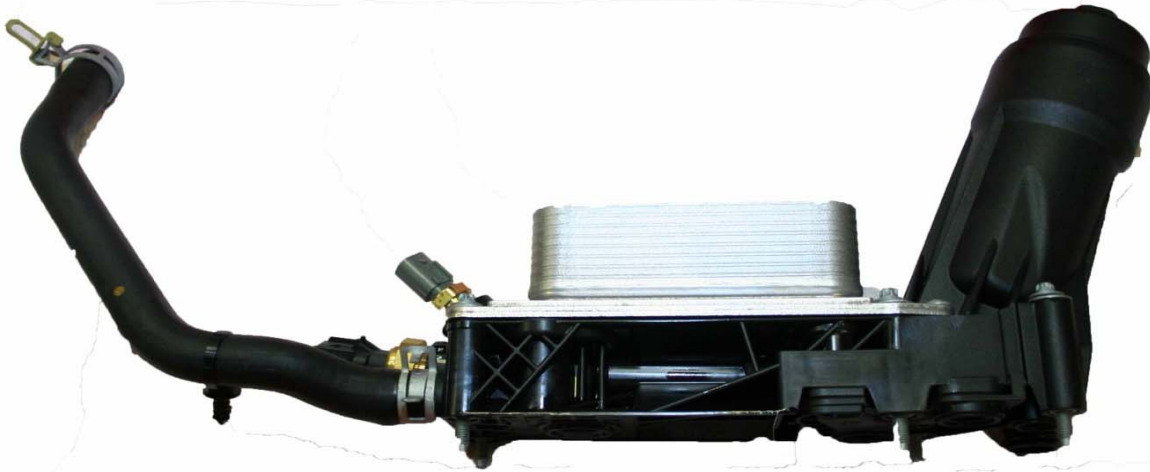

1. Remove the oil filter from the housing assembly.
2. Clean the oil side of the oil cooler and filter assembly with Engine Degreasing Solvent. Technicians should follow laboratory practices to ensure the solvent thoroughly saturates the inside of the cooler.
3. Drain the solvent from the cooler assembly and air dry the oil cooler and filter housing assembly. Technicians should follow laboratory practices to ensure the cooler is dry and not retaining any solvent. See Section 5 Sheet 6 for additional views.

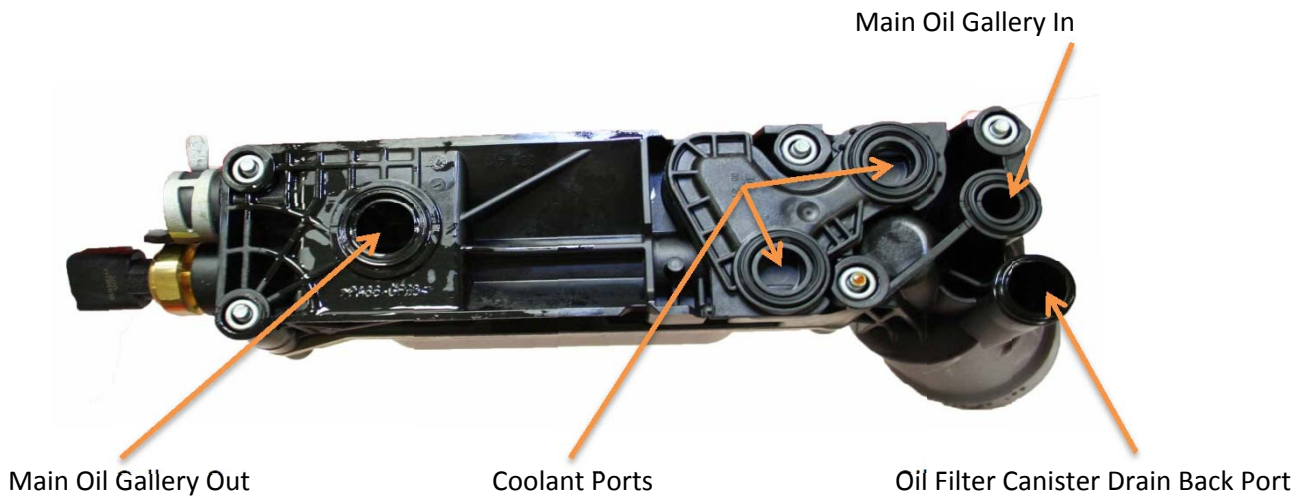

68191356AA O-Ring Kit, Oil Filter Adaptor (Five O-Rings)

## Oil Cooler &amp; Filter Adapter Housing

## Disassembled Views:

1. Oil Cooler separated from Adaptor Housing.  
Note: Oil Cooler "O-rings are not serviceable.

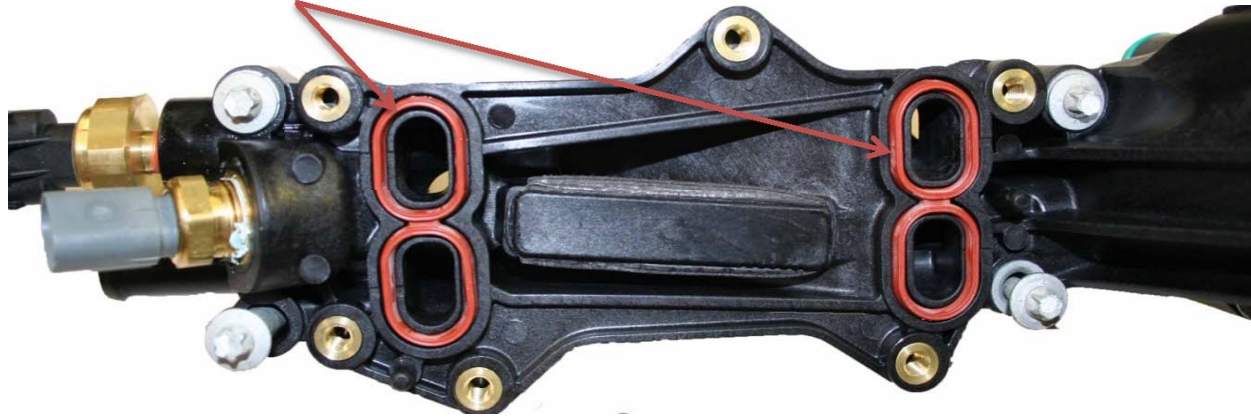

2. With the cooler separated from the housing, both the cooler and housing can be cleaned much easier.



68191349AB Element, Oil Filter 2014 and Newer Engines



## Section 6

### Cylinder Head Pre-Build Cleaning and Assembly



Revision DRAFT	Cylinder Head Pre Build Cleaning	Section	6
Jul-15		Sheet	1

Cylinder heads are specially processed through IMTS to insert special Stellite Hardened Intake Valve Seats.

Cylinder heads may be cleaned using the Ultra Sonic Cleaner followed by water rinse and solvent cleaning.

Clean the cylinder heads using Engine Degreasing Solvent followed by a spray using a 50/50 solution of Engine Degreasing Solvent and EF-411 and air drying.

Cylinder heads are processed with the oil gallery plugs (2 bolts) installed to help prevent machining debris and manufacturing fluids from entering the oil galleries.

Labs may choose to remove and re-install these bolts during the cleaning process.

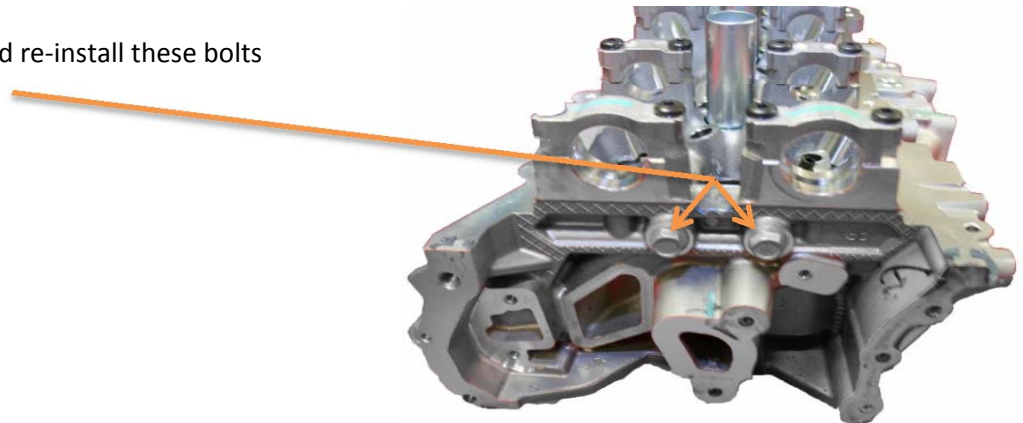

Camshaft Journal Caps should be left on the cylinder head during the cleaning process

Technicians should ensure all oil galleries are clean and clear of any debris



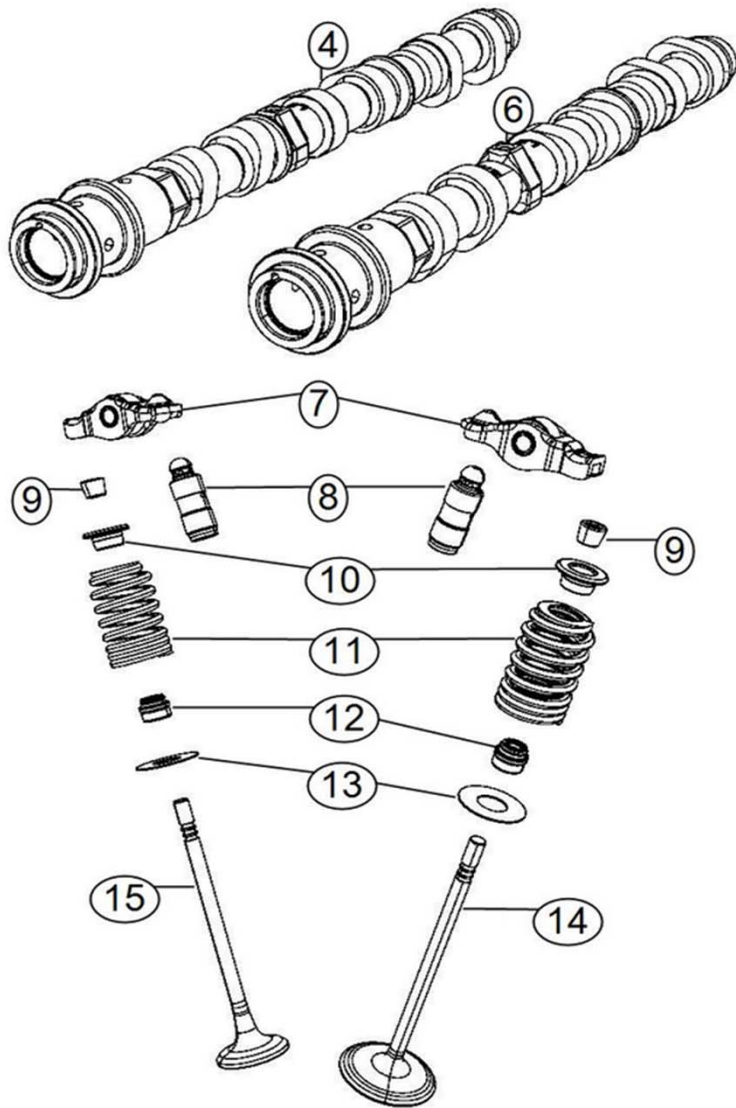

Mopar Parts Illustration

- |                                       |                                       |
|---------------------------------------|---------------------------------------|
| 4. 05184379AF Camshaft, Intake, Left  | 9. 04663722 Lock, Valve Retainer      |
| 05184380AF Camshaft, Intake, Right    | 10. 05184126AB Retainer, Valve Spring |
| 6. 05184377AF Camshaft, Exhaust, Left | 11. 05184060AN Spring, Valve          |
| 05184378AF camshaft, Exhaust, Right   | 12. 05184168AB Seal, Valve Stem, Oil  |
| 7. 05184296AF Arm, Rocker, Roller     | 13. 05184167AB Seat, Valve Spring     |
| 8. 05184332AA Adjuster, Lash          | 14. 05184128AE Valve, Exhaust         |
|                                       | 15. 05184127AC Valve, Intake          |

Revision DRAFT	Cylinder Head Assembly	Section	6
Jul-15		Sheet	3

1. If removed, install the two oil gallery plugs (bolts) with a small amount of Loctite 545 or 567, ensuring the Loctite material starts a couple threads back from the front of the bolt. (Do not use excessive amounts of sealer)

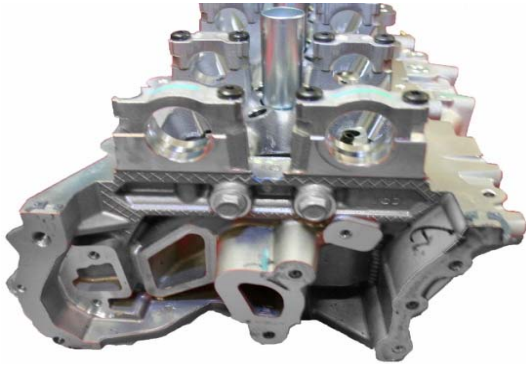

2. Lubricate the valve guides and valve stems with EF-411 as you assemble the cylinder head.
3. Install each valve, one at a time, and using an appropriate valve seal installation tool with a valve stem seal protector, lubricate each seal with EF-411 and install the seal over the valve stem & protector. Push the seal firmly over the valve guide. **Do Not Force the seal against the top of the valve guide.**

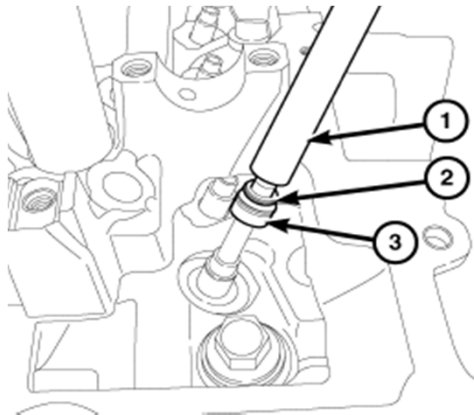

Ensure the Garter Spring (2) is intact around the top of the valve guide seal after installation.

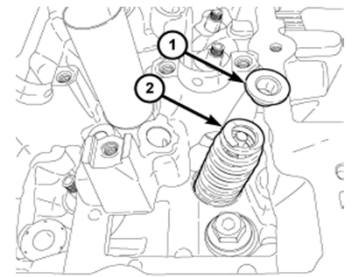
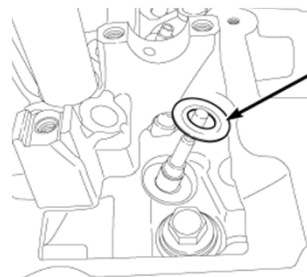

4. Lubricate the valve spring seat with EF-411 and install.
5. Lubricate the valve spring with EF-411 and install.
6. Lubricate the valve spring retainer with EF-411 and using a valve spring compressing tool, compress the assembly to the point where the valve stem locks can be inserted and release the valve spring compressing tool.

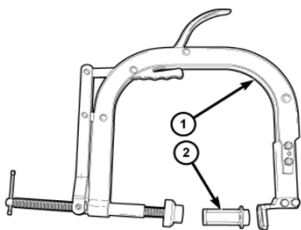
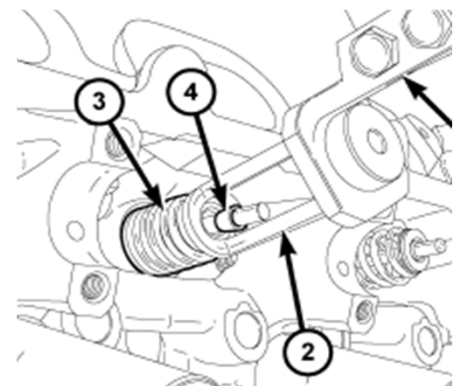

- (1) Valve Spring Compressor C-3422-D
- (2) Valve Spring Compressor Adapter 10224

Example Tools from RT Manual

Section 7  
Short Block Assembly and General Information

Revision DRAFT	Short Block Assembly General Information	Section	7
Jul-15		Sheet	1

The cylinder block is a 60 degree high-pressure die cast aluminum design with cast steel cylinder liners. The leading side of the block is on the right side and houses cylinders 1, 3 and 5. The cylinder block is an open deck design with cut slots between each cylinder. Two knock sensors are located in the block valley. The cylinder block has three sets of piston cooling jets which are attached to the main oil gallery. The four powdered metal main bearing caps are a cross-bolted design and have directional arrows molded into the caps. The number 2 main bearing is the location for the two piece upper half thrust bearings. The thrust bearings are installed with the oil grooves facing outward. The main bearing caps are a 6-bolt design and cross-bolted for improved lower end strength. There are three oil drain back drillings located on

Blocks and crankshafts are precision measured during manufacture and marked with specific bore and journal size identifications. Bearing shells are manufactured to provide select fit clearances based on these

**Note:**

Engines should be kept with their respective parts as select fit clearances will differ between each engine. Clearances may be confirmed through actual measurements with reference to the following bearing selection charts and identification markings on the block and crankshaft. See Section 5 Sheet 2

**Note:**

Crankshaft thrust washers are not selectable and are only available in single thickness.

**Caution:**

Main bearing fasteners are snug torque plus angle tightening. Main bearing fasteners are Not Yield Fasteners. Main bearing fasteners have been torqued twice during manufacture. Labs should strive to minimize the number of torque applications during test build. If threads in the block are pulled during assembly, the labs are allowed to use thread inserts, however, labs must understand the main caps are positioned through the shoulder of the fastener and threaded inserts could cause misalignment.

**Note:**

Main Bearing cap bolts are replaced as necessary.  
Cylinder head bolts are reused for torque plate application during honing.  
Cylinder head bolts are replaced with new fasteners for test build.  
Connecting rod cap bolts are replaced for test build.

All reused fasteners should be checked for necking before use.

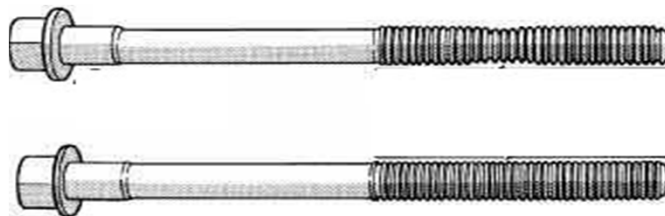

The connecting rod bearings are “select fit” to achieve proper oil clearance. Connecting rod bearing journal diameter grade markings are stamped into the front crankshaft counterweight. Markings read from left to right journals 1 through 6.

The connecting rod bearing shells (1) are marked with the bearing size (2) on the bearing lining surface.

The bearings are available in three different sizes in order to achieve the desired oil clearance.

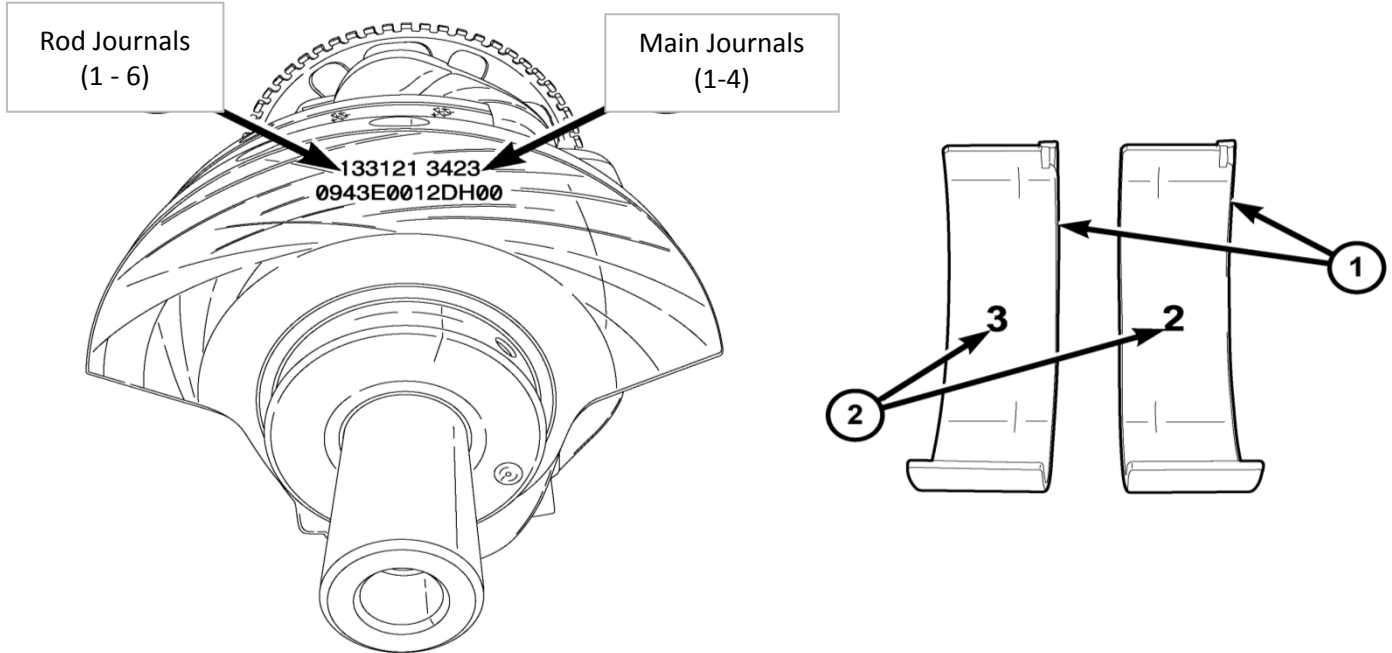

Rod bearing shells are available in three sizes. The chart below identifies the three bearing sizes.

Crankshaft Marking	Journal Size mm (Inch)
1	58.9910 - 58.9969mm (2.3225 - 2.3227 in.)
2	58.9970 - 59.0029mm (2.3227 - 2.3229 in.)
3	59.0030 - 59.0090mm (2.3229 - 2.3232 in.)

Bearing Marking	Bearing Shell Size mm (Inch)
1	1.583 - 1.580mm (0.0623 - 0.0622 in.)
2	1.580 - 1.577mm (0.0622 - 0.0621 in.)
3	1.577 - 1.574mm (0.0621 - 0.0620 in.)

**Install rod bearings in pairs, Do Not Mix connecting rod bearing shells**

05184111AF Bearing, Rod, Grade 1 (+0.003mm)

05184112AF Bearing, Rod, Grade 2 (std.)

05184113AF Bearing, Rod, Grade 3 (-0.003mm)

The upper and lower main bearings are “select fit” to achieve proper oil clearances. Crankshaft main bearing journal diameter grade markings are stamped into the front crankshaft counterweight. These marks are read from left to right, corresponding with journal number 1, 2, 3, 4. See Section 5 Sheet 2

Crankshaft Marking	Journal Size mm (Inch)
1	71.9870 - 71.9905 (2.8341 - 2.8343 in.)
2	71.9906 - 71.9941 (2.8343 - 2.8344 in.)
3	71.9942 - 71.9977 (2.8344 - 2.8345 in.)
4	71.9978 - 72.0013 (2.8346 - 2.8347 in.)
5	72.0014 - 72.0050 (2.8347 - 2.8348 in.)

Engine block main bore size identification from the left, front to rear ( 1 - 4).

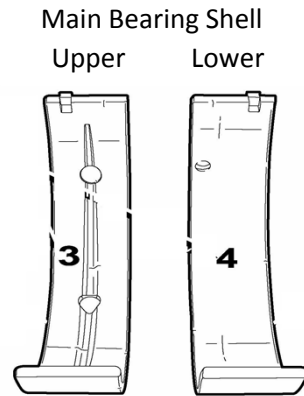
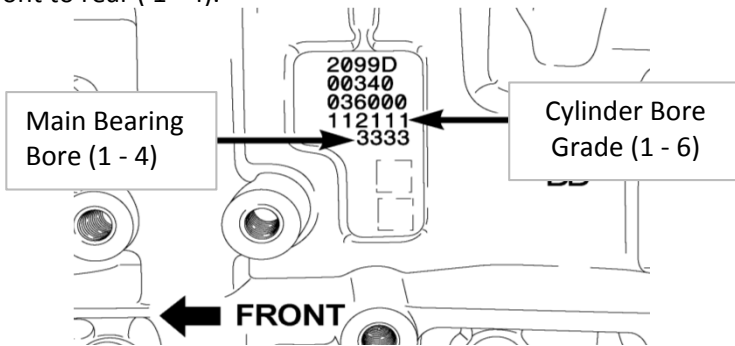

Engine Block Marking	Main Bore Size mm (Inch)
1	77.0055 - 77.0090 (3.0317 - 3.0318 in.)
2	77.0019 - 77.0054 (3.0316 - 3.0317 in.)
3	76.9983 - 77.0018 (3.0314 - 3.0316 in.)
4	76.9947 - 76.9982 (3.0313 - 3.0314 in.)
5	76.9910 - 76.9946 (3.0311 - 3.0313 in.)

Engine Block Marking	Crankshaft Marking				
	1	2	3	4	5
1	1/1	1/2	2/2	2/3	3/3
2	1/2	2/2	2/3	3/3	3/4
3	2/2	2/3	3/3	3/4	4/4
4	2/3	3/3	3/4	4/4	4/5
5	3/3	3/4	4/4	4/5	5/5

Upper / Lower main bearing combinations to achieve 0.024 - 0.050mm (0.0009 - 0.0020 in.) clearance.

Revision DRAFT	Short Block Assembly Piston Ring Gap / Piston Cooling Jets	Section	7
Jul-15		Sheet	4

**Piston Ring Gap Measurement:**

Position the top and second piston rings ~ 1 inch down from the top of the bore. Using a Starrett Taper Gage Model 270, measure the gap and record the pre-test measurement on the appropriate engine build data form. **Note: Labs perform all ring gap measurements with the BHI Torque Plates still installed on the engine. This view is for illustration only.**



**Cylinder Bore Cleaning:**

Because the piston cooling jets protrude into the bottom of the cylinder bore, technicians should consider cleaning the cylinder bores and oiling them for piston installation before piston cooling jet installation.

Clean the cylinder bores with clean lint free terry towels using EF-411 to ensure cylinder bores are clean and debris free for continued assembly.



**Piston Cooling Jets:**

Lubricate the O-ring on the piston cooling jet with EF-411 engine assembly lube.

Install the piston cooling jet and torque the fastener to 6 N·m (53 in. lbs.).

Piston cooling jets are targeted during manufacture. Care should be exercised not to damage or bend the nozzle during handling.

Piston cooling jets have a check valve which closes below 2.5 bar (35 psi). Piston cooling jets should be replaced every test.

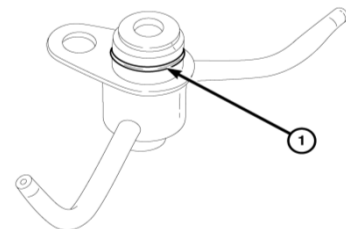



Revision DRAFT	Short Block Assembly Oil Gallery Plugs	Section	7
Jul-15		Sheet	5

Oil Gallery threaded holes are straight thread. Oil gallery threaded plugs are taper pipe thread. These plugs are installed at the factory using a pre-snug value plus a very large number of degrees rotation to drive the tapered thread into the straight thread. These plugs also use a special thread sealant. When removed the same installation specifications cannot be used for re-installation.

Build Technicians must acquire a feel for obtaining the proper torque on the main oil gallery plugs and fittings used for pressure taps and temperature thermocouples in the main oil gallery.

Recommended sealants for these operations are;

Threaded Gallery Plugs: Loctite 545, Loctite 567, Loctite #2 (Permatex #2), Teflon Tape

**Caution:** When applying sealants, technicians should try to keep the sealants away from the first two threads of the plug or thermocouple fitting to keep sealants from rolling over the threads and into the oil gallery.

Recommended sealant for the Front Oil Gallery Cup Plug;  
Cup Plug: Loctite 648 Retaining Compound

04556020AB Plug, Cup, Front Oil Gallery

When installing the front cup plug, use a properly sized driver and install the cup plug until the front edge is 1mm deep from the front face of the block or beyond the chamfered edge of the gallery.

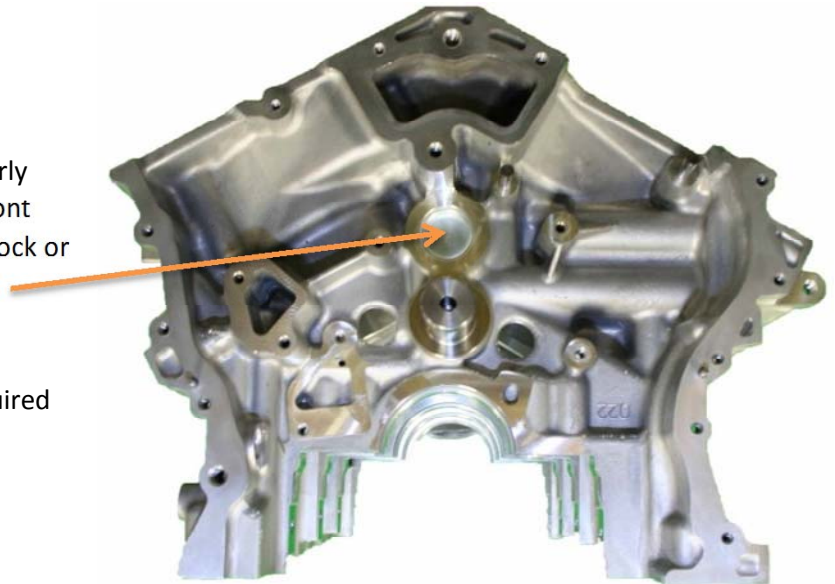

Install the side and rear oil gallery plugs as required for test operations.

Install the main oil gallery thermocouple fitting using lab preference sealing compounds

Recommended fitting:  
Swagelok Tube Fitting SS-200-1-1BT  
1/8" Tube O.D. x 1/16 Male NPT

Use IMTS 151132-F002 Thermocouple Setting Fixture to position the tip of the main oil gallery thermocouple in the center of the gallery.

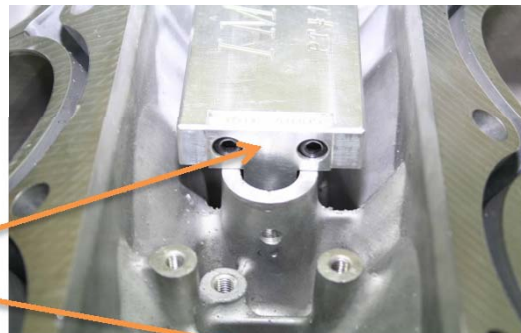

**Engineering Recommendation:**

Some labs have experienced oil leaks at the main oil gallery thermocouple fitting. Leaks may be related to 50/50 EF-411 in the threads from the cleaning process. Cleaning the threads with a non-lubricated type contact cleaner has been found to help. Air dry all residue from any cleaning products and inspect main oil gallery for any residues from cleaners or sealants after installing the thermocouple.

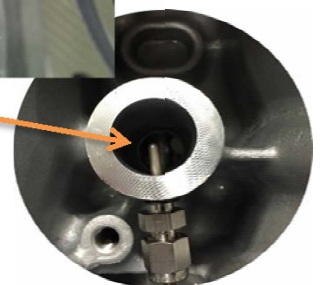

Revision DRAFT	Short Block Assembly Main Bearing / Crankshaft Installation	Section	7
Jul-15		Sheet	6

Refer to Section 5 Sheet 3 for main bearing selection.

**Main Bearing Selection:**

Check the crankshaft identification codes on the front counterbalance for the main journal diameter codes and record the data in the appropriate build document.

Check the engine block identification codes on the identification pad for the main bearing bore codes and record the data in the appropriate build document.

Using the table in Section 5 Sheet 2, select the appropriate bearings for the engine block / crankshaft combination and record the information in the appropriate build document.

Main Bearing Shell  
Upper      Lower

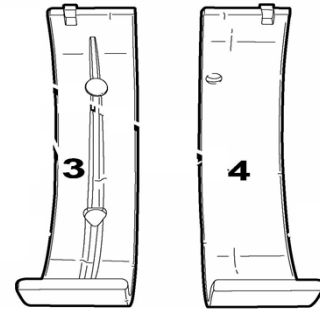

In all positions, the upper bearing should be equal to or less than the lower main bearing selection.

Install the upper main bearings in positions 1 - 4.

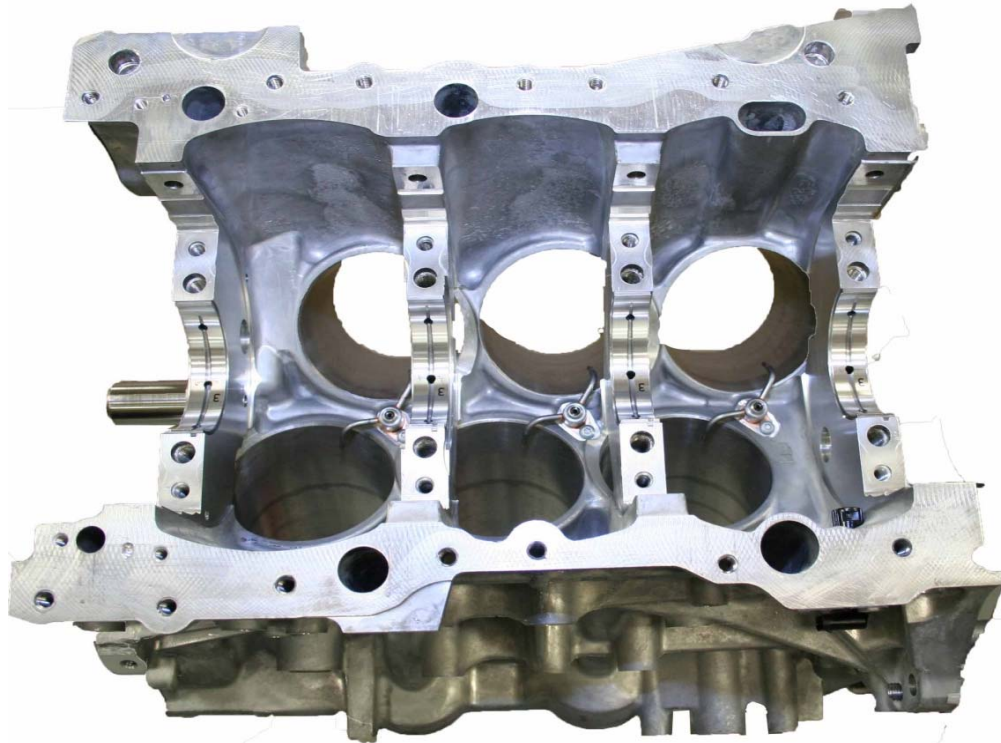

**Part Numbers:**

- 05184103AI      MAIN BEARING UPPER Grade 1
- 05184104AI      MAIN BEARING UPPER Grade 2
- 05184105AI      MAIN BEARING UPPER Grade 3
- 05184106AI      MAIN BEARING UPPER Grade 4
- 05184107AI      MAIN BEARING UPPER Grade 5

Revision DRAFT	Short Block Assembly Main Bearing / Crankshaft Installation	Section	7
Jul-15		Sheet	7

Lubricate the upper main bearings using EF-411 Assembly Oil.

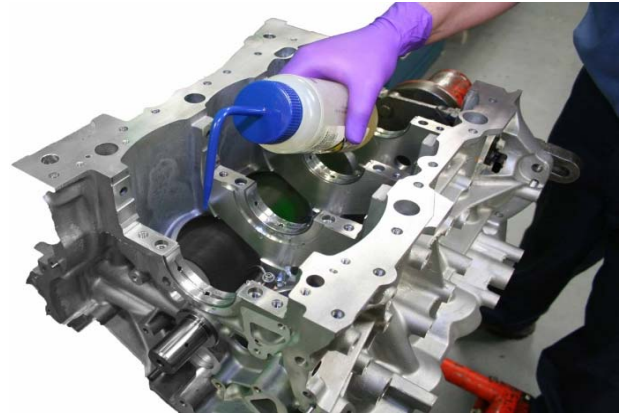

Install the crankshaft and lubricate the journals with EF-411 Assembly Oil.

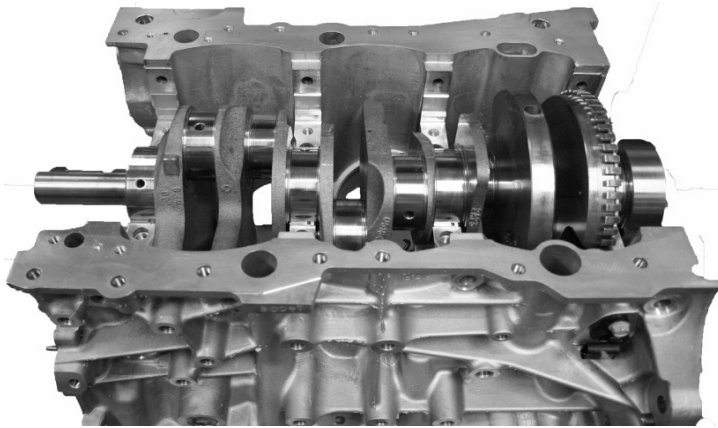

Install the thrust washers

Installing thrust washers (1) at the No. 2 main bearing location, using the following procedure:

- a. Move the crankshaft forward to the limit of travel. Lubricate and install the front thrust washer (1) by rolling the washer onto the machined shelf between the No. 2 upper main bulk head and crankshaft thrust surface.
- b. Move the crankshaft rearward to the limit of travel. Lubricate and install the rear thrust washer by rolling the washer onto the machined shelf between the No. 2 upper main bulk head and crankshaft thrust surface.



Revision DRAFT	Short Block Assembly Main Bearing / Crankshaft Installation	Section	7
Jul-15		Sheet	8

Install the lower main bearings in the main caps (1 - 4).

**Part Numbers:**

- 05184086AH MAIN BEARING LOWER Grade 1
- 05184087AH MAIN BEARING LOWER Grade 2
- 05184088AH MAIN BEARING LOWER Grade 3
- 05184089AH MAIN BEARING LOWER Grade 4
- 05184090AH MAIN BEARING LOWER Grade 5



Install the lower main bearing caps with bearings. Lubricate the inner fasteners with EF-411 and snug the fasteners using a speed handle to draw the main caps down uniformly to seating the main caps. Back the fasteners off and check the forward and aft movement of the crankshaft.



Torque the inner main cap fasteners to 20 N·m (15 ft. lbs.) plus 90° following the inside out pattern shown in View A.



Install the eight main bearing tie bolts. Tighten the bolts in the sequence shown in View B to 28 N·m (21 ft. lbs.).

Note: Crankshaft may be tight until side bolts are installed and windage tray is torqued.

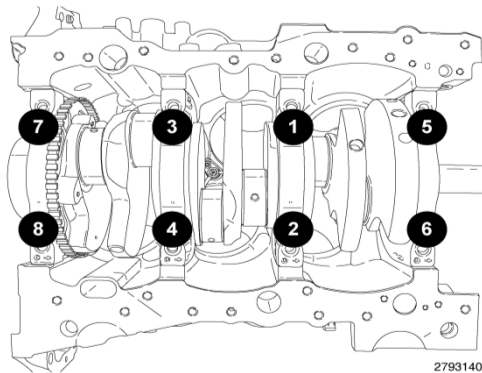

View A

2793140

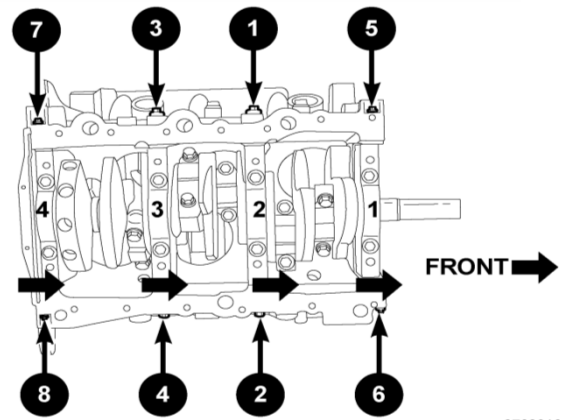

View B

2792316

Revision DRAFT	Short Block Assembly Piston Assembly	Section	7
Jul-15		Sheet	9

Remove the connecting rod from the production piston assembly



Note:  
GNORF  
Geometric  
Nomenclature  
on Rod Face

Tab on bottom  
of connecting  
rod denotes  
FRONT

Install the production connecting rod on the OHT Test Piston using the new piston pin and spiral clips

- Part Numbers:
- OHT3H-070-1 PISTON, SPECIAL TEST
  - OHT3H-071-1 PIN, WRIST, PISTON
  - OHT3H-072-1 CLIP, PISTON, WRIST PIN
  
  - 06509128AA Bolt, Rod, Connecting

See Section 7 Sheet 2 for Rod Bearing selection.

**Caution:**

To avoid damage to the piston rings, they must be installed in the following order:

- Oil ring expander (5)
- Oil ring lower side rail (4)
- Oil ring upper side rail (3)
- No. 2 (intermediate) piston ring (2)
- No. 1 (upper) piston ring (1)

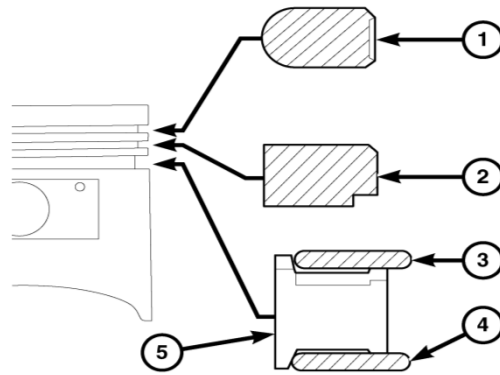
**Note:**

Typical piston shown. Do not use a piston ring expander to install the oil ring side rails.

Install the oil ring expander (1).

Install the oil ring lower side rail by placing one end between the piston ring groove and the oil ring expander. Hold this end firmly and press down the portion to be installed until the side rail is in position.

Install the oil ring upper side rail in the same manner as the lower side rail.

The No. 1 (upper) piston ring (1) and No. 2 (intermediate) piston ring (3) have a different cross section. Install the rings with manufacturers I.D. mark (dot) (2) facing up, towards the top of the piston.

Install the 2nd and top piston rings using the same method by placing one end of the ring into the piston ring groove and rolling the ring around the piston into the groove. Use care to prevent over expanding the piston ring during this operation and also not to allow the gap edge to scratch the piston land area.

**Do Not Use Piston Ring Expanders as these are low tension rings and over expanding will change the tension.**



## Part Numbers:

3H96040-TOP RING, SPECIAL TEST, UCR (.025" GAP, 96.040 BORE)

3H96040-SECONRING, SPECIAL TEST, LCR (.035" GAP, 96.040 BORE)

3H96040-EXP EXPANDER, SEQ. IIIH

3H96040-RAIL RAIL, SEQ. IIIH

Revision DRAFT	Short Block Assembly Piston Installation	Section	7
Jul-15		Sheet	11

Refer to Section 5 Sheet 2 for connecting rod bearing selection.

**Connecting Rod Bearing Selection:**

Check the crankshaft identification codes on the front counterbalance for the connecting rod journal diameter codes and record the data in the appropriate build document.

Using the table in Section 7 Sheet 2, select the appropriate bearings for the connecting rod journal codes (1 - 6) on the crankshaft and install the bearing sets in the respective locations.

Connecting Rod Shells

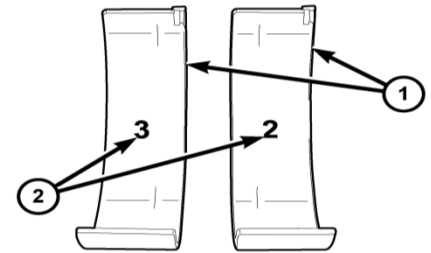

The bearings are available in three different sizes in order to achieve the desired oil clearance. The connecting rod bearing shells (1) are marked with the bearing size (2) on the bearing lining surface.

**Install rod bearings in pairs, Do Not Mix connecting rod bearing shells**

(1 top 1 bottom) (2 top 2 bottom) (3 top 3 bottom)

Use proper sized piston installation sleeve with piston installation guides to install piston assemblies. Lubricate the piston rings and piston skirt with EF-411 and slide the piston assembly into the installation sleeve using care to ensure the piston rings are in proper position during installation.



Piston ring installation sleeve with rubber tubing used as an installation guide  
(In-house fabricated)

Position the crankshaft journal at BDC.

Clean the cylinder with a lint free cloth or Teri towel.

Oil the cylinder with EF-411.

Position the piston assembly with the forward identifying mark (1) facing forward on each bank.

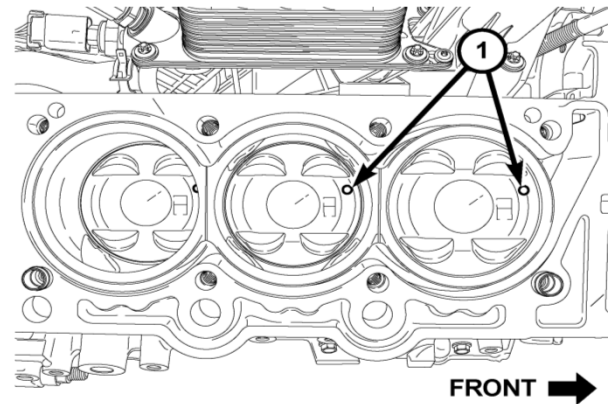

Carefully guide the piston assembly into the cylinder using care not to contact the piston cooling jet.

Position the connecting rod guide in proper alignment with the crankshaft journal.

Ensure the upper connecting rod bearing is in place and lubricate the bearing and rod journal with EF-411.





Hold the piston installation sleeve firmly against the cylinder block deck.  
Using a plastic mallet, tap the piston assembly into the cylinder until the rings completely enter the cylinder.  
Check to ensure the rod bearing is still in the proper position and push the assembly into the cylinder until the rod and bearing seat against the crankshaft journal.



Lubricate the rod cap and lower bearing with EF-411 and install using new connecting rod fasteners.

Tighten the NEW connecting rod cap bolts to 20 N·m (15 ft. lbs.) plus 90°

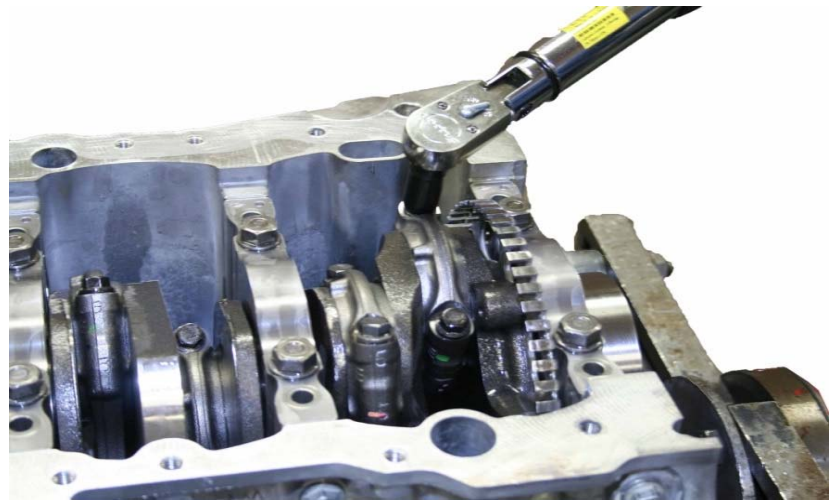

Part Number  
06509128AA Rod Bolt

Section 8  
Long Block Assembly

Revision DRAFT	Long Block Assembly Rear Crankshaft Oil Seal	Section	8
Jul-15		Sheet	1

The rear crankshaft oil seal (2) and retainer (1) are an assembly. To avoid damage to the seal lip, DO NOT remove the seal protector (3) from the rear crankshaft oil seal before installation onto the engine.

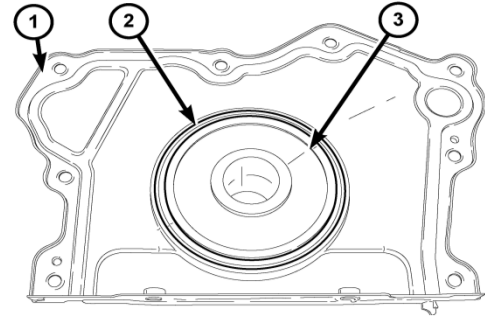

**Note:**

Labs will be reusing the rear cover with the crankshaft oil seal.  
 Labs should purchase some new rear cover assemblies to acquire the pilot guide for installation of the rear cover oil seal assembly.  
 Part Number:  
 68152024AA    RETAINER ASM - CRANKSHAFT REAR MAIN OIL SEAL  
 68223854AA    Alternate service part number

Carefully position the oil seal retainer assembly and seal protector on the crankshaft and push firmly into place on the engine block.  
 During this step the seal protector will position the cover and seal assembly by piloting off the rear pilot of the crankshaft. The seal protector will be pushed from the assembly during installation.  
 Insure the lip seal on the crankshaft is uniformly curled inward and the cover is flush with the oil pan sealing surface.

Install the eight seal retainer bolts and tighten to 12 N·m (106 in. lbs.).

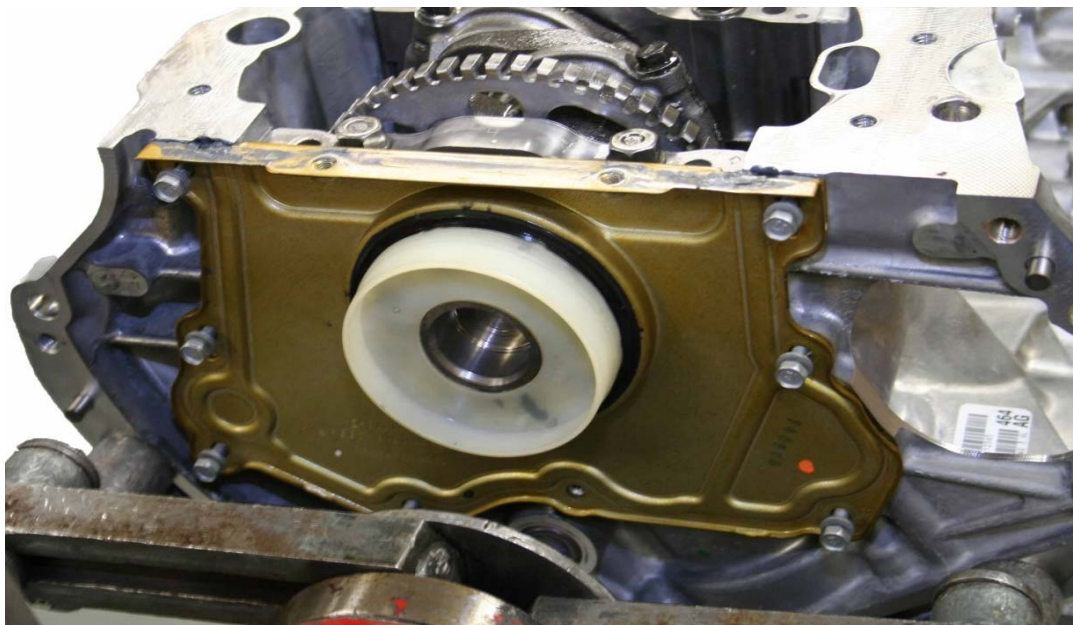

Revision DRAFT	Long Block Assembly Cylinder Head Installation	Section	8
Jul-15		Sheet	2

**CAUTION:**

**Do Not Use Metal Scrapers on Cylinder Deck or Cylinder Head Surfaces.**

Use only plastic type scrapers for cleaning these surfaces.

**WARNING:**

Multi-layered steel head gaskets have very sharp edges and could cause personal injury if not handled properly.

Install new head gaskets every engine build.

Part Numbers:

05184455AG GASKET - CYLINDER HEAD LH

05184456AG GASKET - CYLINDER HEAD RH



**CAUTION:**

Cylinder head bolt holes are blind holes. Debris such as RTV sealants, coolant, engine oil, or cleaning solvents can cause hydraulic locking and aluminum castings to crank when tightening cylinder head fasteners.

**Make sure cylinder head bolt holes are clean and dry.**

Install both cylinder head gaskets placed firmly over the locating dowels.



Revision DRAFT	Long Block Assembly Cylinder Head Installation	Section	8
Jul-15		Sheet	3

Install the cylinder heads ensuring the heads seat firmly over the locating dowels.



Cylinder head bolts are Yield Type Fasteners.

Fasteners from the New Engine Disassembly are used for honing with the BHJ Torque Plates.

New fasteners are used for every test engine build.

06509564AA Bolt, Cylinder Head



Lubricate new cylinder head fasteners with EF-411

Allow fasteners to drip free of excess oil and blot with clean Teri towel before inserting into cylinder head.

Revision DRAFT	Long Block Assembly Cylinder Head Installation	Section	8
Jul-15		Sheet	4

**Use new cylinder head bolts for test engine build. Follow clockwise inside out tightening sequence for both sides.**

**Note:**

Engine test build requires conditioning steps 1 - 4, unlike torquing used fasteners used for honing which only requires steps 6 - 9.

Tighten the cylinder head fasteners in sequence following this 9 step torque plus angle procedure.

Tighten all fasteners in sequence from the inside out as shown in view A.

Perform each step on all fasteners in sequence

Step 1: 30 N·m (22 ft. lbs.)

Step 2: 45 N·m (33 ft. lbs.)

Step 3: plus 75°

Step 4: plus 50°

Step 5: Loosen all fasteners in reverse order i.e., position 8, 7, 6,... etc.

Step 6: 30 N·m (22 ft. lbs.)

Step 7: 45 N·m (33 ft. lbs.)

Step 8: plus 70°

Step 9: plus 70°

View A

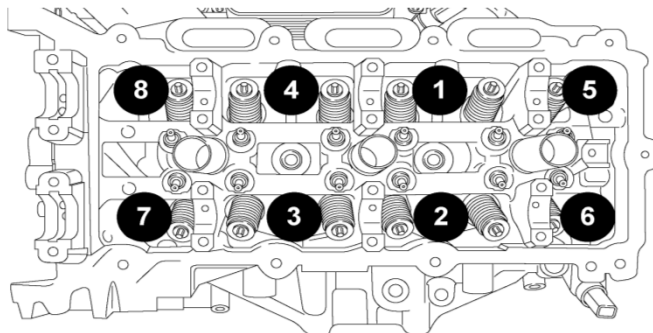

Revision DRAFT	Long Block Assembly Valvetrain Assembly	Section	8
Jul-15		Sheet	5

Before installing any valvetrain gear, position the crankshaft on TDC #1 by aligning the dimple (2) on the crankshaft with the block / bearing cap junction (1).

Ensure the crankshaft drift key is positioned in the key way cut in the crankshaft (3).

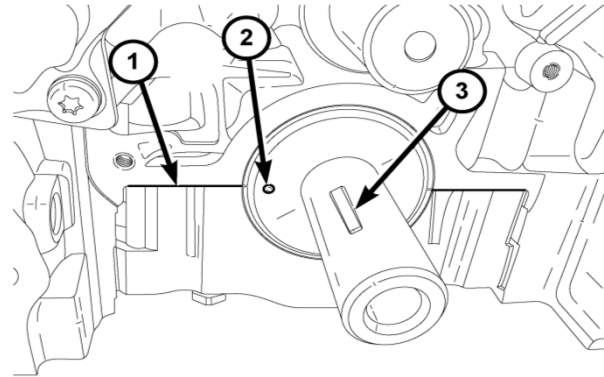

**CAUTION:**

**Do Not Rotate the Crankshaft or Camshafts any further than directed in the timing chain installation procedure from this point forward as bent valves will result.**

Lubricate the lash adjusters and roller rockers with EF-411 and install in 24 positions on the cylinder heads.



05184332AA Adjuster, Lash

05184296AF Roller, Rocker

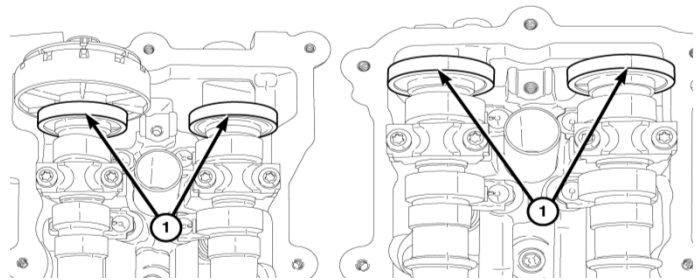

**CAUTION:**

The magnetic timing wheels (1) must not come in contact with magnets (pickup tools, trays, etc.) or any other strong magnetic field. This will destroy the timing wheels ability to correctly relay camshaft position to the camshaft position sensor.

Remove the production phasers from the intake and exhaust camshafts.

Lubricate the OHT Fixed Phasers and the nose of the intake and exhaust camshafts.

Install the OHT Fixed Phasers on the intake and exhaust camshafts and hand tighten the oil control valves.

- OHT3H-001-1 Fixed Phaser, Intake
- OHT3H-002-1 Fixed Phaser, Exhaust



Remove the camshaft bushing caps from the cylinder heads.

Lubricate the camshaft journals with EF-411 and install all four camshafts in their neutral load positions.

#### Right Side

Install the right side camshaft(s) at top-dead-center by positioning the alignment holes (1) vertically. This will place the camshafts at the neutral position (no valve load) easing the installation of the camshaft bearing caps.

Install the camshaft bearing caps and hand tighten the retaining bolts to 2 N·m (18 in. lbs.).

Caps are identified numerically (1 - 4), intake or exhaust (I or E) and should be installed from the front to rear of engine. All caps should be installed with the notch forward so that the stamped arrows (<) on the caps point toward the front of the engine.

Tighten the bearing cap retaining bolts in the sequence shown to 9.5 N·m (84 in. lbs.).

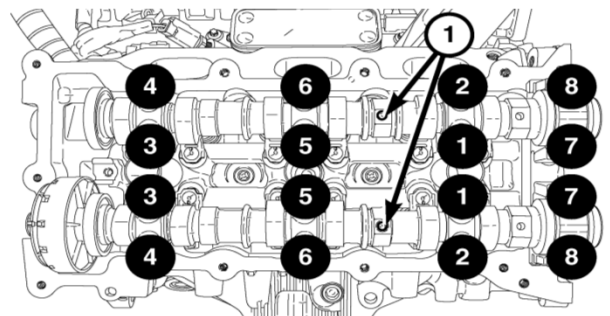
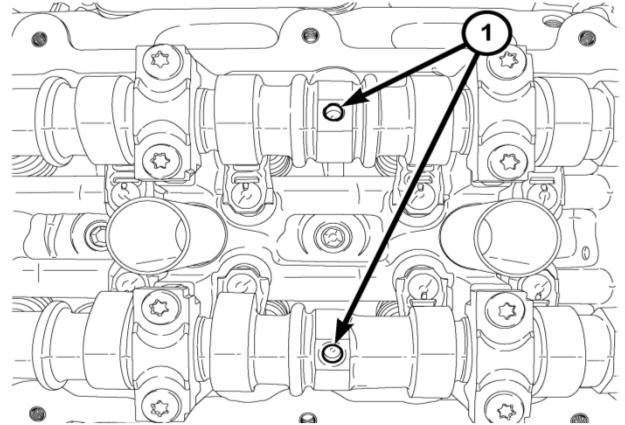

TDC Neutral Load Alignment (Holes Vertical)

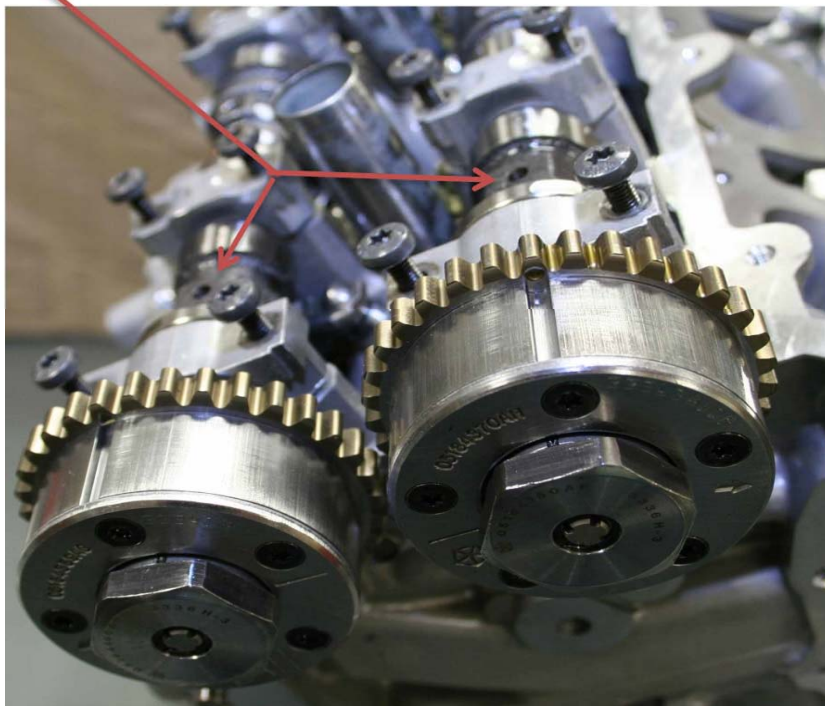



Revision DRAFT	Long Block Assembly Valvetrain Assembly	Section	8
Jul-15		Sheet	7

Remove the camshaft bushing caps from the cylinder heads.  
Lubricate the camshaft journals with EF-411 and install all four camshafts in their neutral load positions.

Install the left side camshaft(s) with the alignment holes (1) positioned approximately 30° before top-dead-center. This will place the camshafts at the neutral position (no valve load) easing the installation of the camshaft bearing caps.

Install the camshaft bearing caps and hand tighten the retaining bolts to 2 N·m (18 in. lbs.).

Caps are identified numerically (1 - 4), intake or exhaust (I or E) and should be installed from the front to rear of engine. All caps should be installed with the notch forward so that the stamped arrows (<) on the caps point toward the front of the engine.

Tighten the bearing cap retaining bolts in the sequence shown to 9.5 N·m (84 in. lbs.).

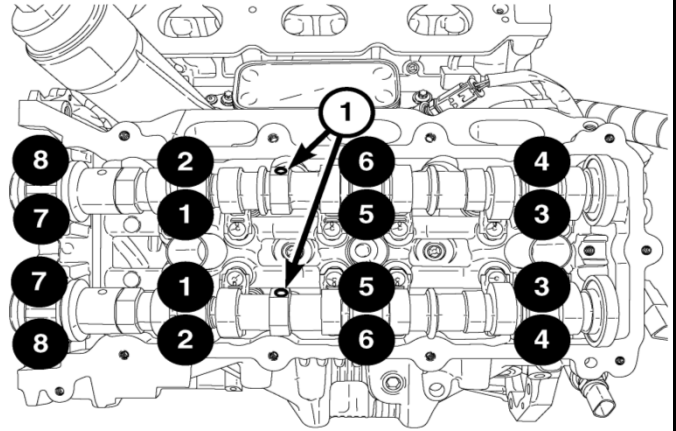

TDC Neutral Load Alignment (Holes ~ 30° BTDC)

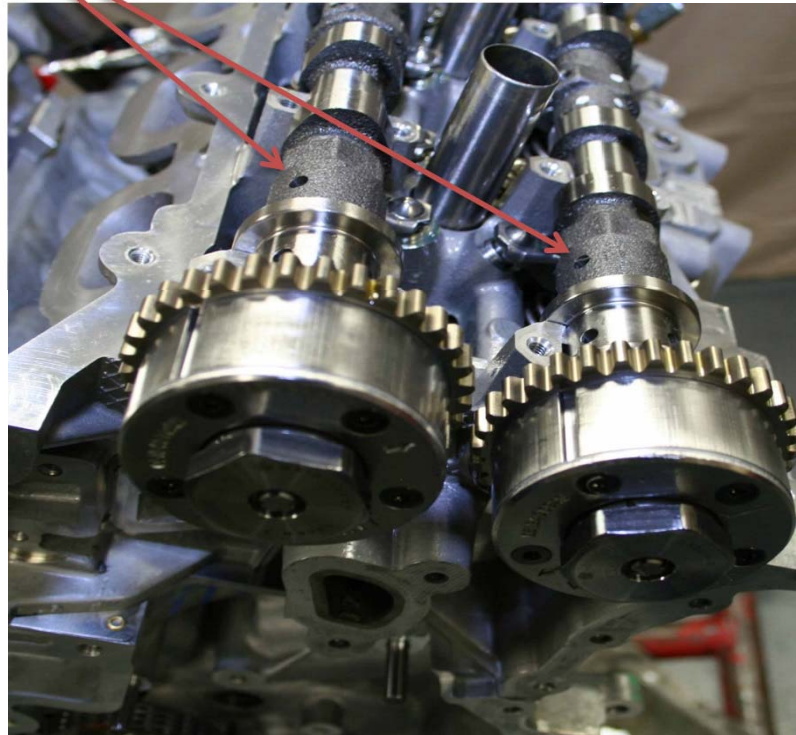

Revision DRAFT	Long Block Assembly Timing Drive Description	Section	8
Jul-15		Sheet	8

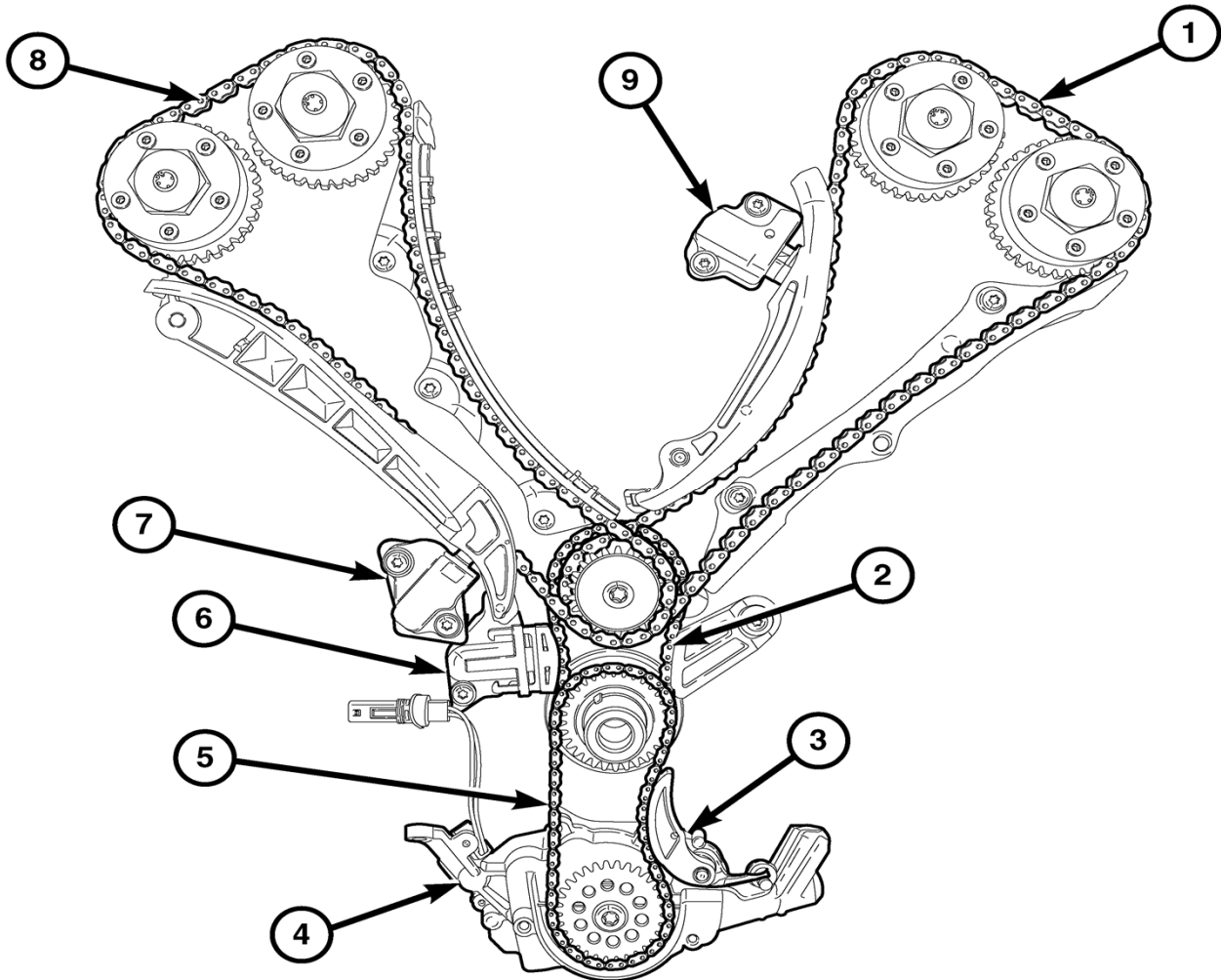

The timing drive uses four silent chains. The silent chain link design improves sprocket engagement and reduces noise, vibration and harshness (NVH). One chain (5) drives the oil pump (4) and three chains drive the camshafts in a two stage design. The left secondary camshaft chain (1) uses an oil pressure controlled chain tensioner (9) with a ratcheting device. The right secondary camshaft chain (8) uses an oil pressure controlled tensioner (7) without a ratchet. The primary chain (2) also uses an oil pressure controlled tensioner (6) without a ratchet. A spring loaded tensioner (3) takes up the slack in the oil pump chain (5). The chain guides and tensioner arms are made of glass filled nylon with nylon wear faces

1. 05184352AF Chain, Timing, Secondary
2. 05184355AF Chain, Timing, Primary
3. 05184093AE Tensioner, Chain, Oil Pump
4. 68252670AA Pump, Engine Oil, Kit
5. 05184278AD Chain, Oil Pump, Drive
6. 05184391AF Tensioner, Chain, Primary
7. 05184888AC Tensioner, Chain, Primary, Right Side
8. 05184352AF Chain, Timing, Secondary
9. 05184360AF Tensioner, Chain, Primary, Left Side

**Resetting the left side chain tensioner**

The slot (2) in the rack provides an anchor point for a pin that holds the rack in the retracted position.

- 1 Using a suitable tool, such as an allen wrench (1), lift the pawl off of the rack.
- 2 While holding the pawl off of the rack, push the rack and the piston into the tensioner body.
- 3 When the slot is aligned with the hole in the tensioner body, insert Tensioner Pin 8514 (1) to hold the rack and piston in the retracted position.

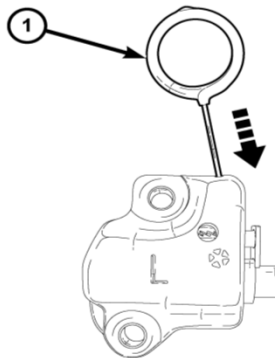
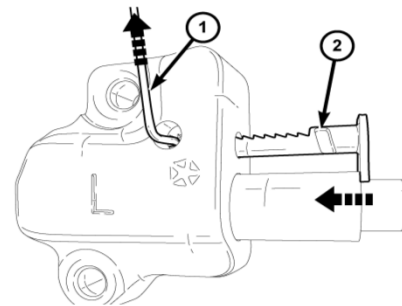
**Installing the camshaft phaser locks**

- 1 Rotate the crankshaft counter clockwise to a position 30° before-top-dead-center. View A

**Note:**

It may be necessary to rock the camshaft slightly (a few degrees) with a wrench (4) when installing the camshaft phaser locks.

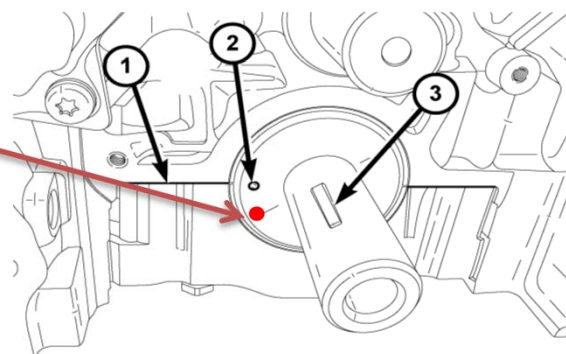
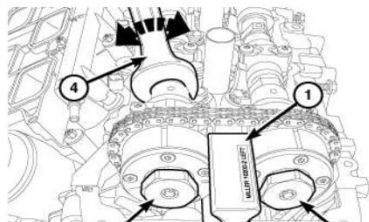

- 2 Install the right side phaser lock 10202-1 with the tool number facing up.
- 3 Install the left side phaser lock 10202- 2 with the tool number facing up.
- 4 Rotate the crankshaft clockwise back to top-dead-center after installing the camshaft phaser locks (2) the camshaft phaser locks (2) shown in View A.

Right Side  
10202 - 1

Left Side  
10202 - 2



- 1 Place the primary chain onto the crankshaft sprocket (3) so that the arrow (2) is aligned with the plated link (1) on the timing chain.

View from back side

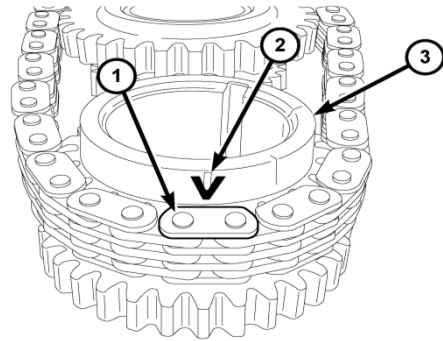

- 2 While maintaining this alignment, invert the crankshaft sprocket and timing chain and place the idler sprocket (4) into the timing chain so that the dimple (2) is aligned with the plated link (1) on the timing chain.

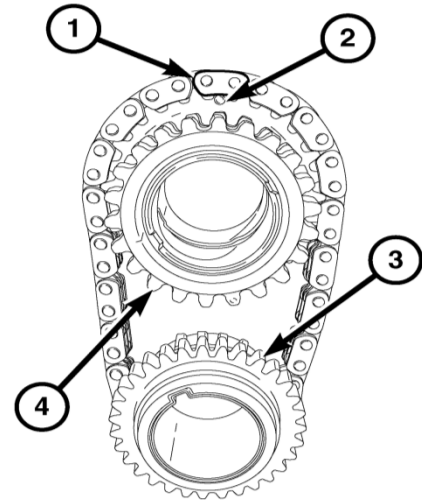

- 3 While maintaining this alignment, lubricate the idler sprocket bushing with clean engine oil and install the sprockets and timing chain on the engine. To verify that the timing is still correct, the timing chain plated link (6) should be located at 12:00 (1) when the dimple (5) on the crankshaft is aligned with the block/bearing cap junction (4).

- 4 Install the idler sprocket retaining bolt (2) and washer (3). Tighten the T45 bolt (2) to 25 N·m (18 ft. lbs.).

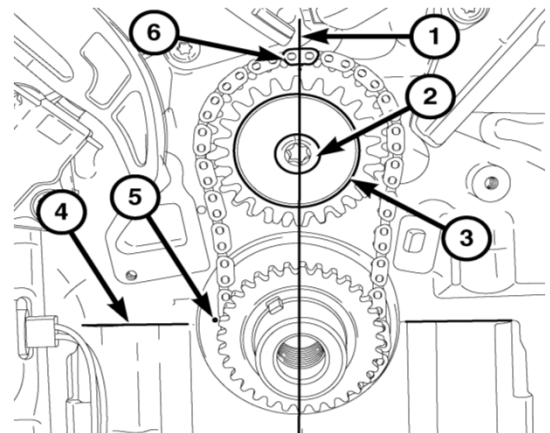

- 5 Install the primary chain guide (2). Tighten attaching T30 bolt (1) to 12 N·m (106 in. lbs.).
- 6 Reset the primary chain tensioner (5) by pushing back the tensioner piston and installing Tensioner Pin 8514 (3).
- 7 Install the primary chain tensioner (5) to the engine block with two bolts (4). Tighten the T30 bolts (4) to 12 N·m (106 in. lbs.) and remove the Tensioner Pin 8514 (3).

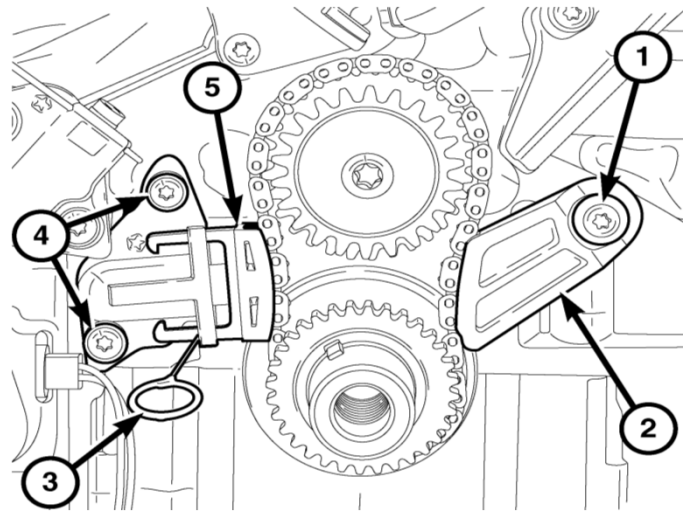

- 8 Install the right side cam chain guide (1) and tensioner arm (6). Tighten attaching T30 bolts (2) to 12 N·m (106 in. lbs.).
- 9 Install the right side cam chain tensioner (3) to the engine block with two bolts (4). Tighten the T30 bolts (4) to 12 N·m (106 in. lbs.).
- 10 Reset the right side cam chain tensioner (3) by pushing back the tensioner piston and installing Tensioner Pin 8514 (5).

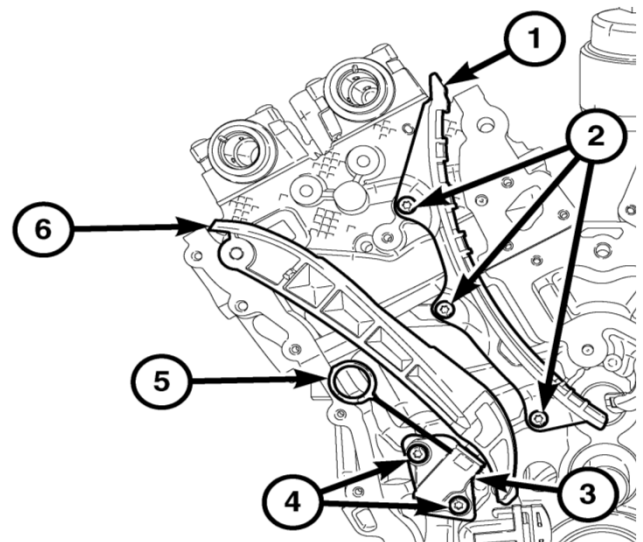

- 11 Install the left side cam chain guide (2) and tensioner arm (1). Tighten attaching T30 bolts (4) to 12 N·m (106 in. lbs.).
- 12 Install the left side cam chain tensioner (5) to the cylinder head with two bolts (6). Tighten the T30 bolts (6) to 12 N·m (106 in. lbs.).
- 13 Reset the left side cam chain tensioner (5) by lifting the pawl (3), pushing back the piston and installing Tensioner Pin 8514 (7)

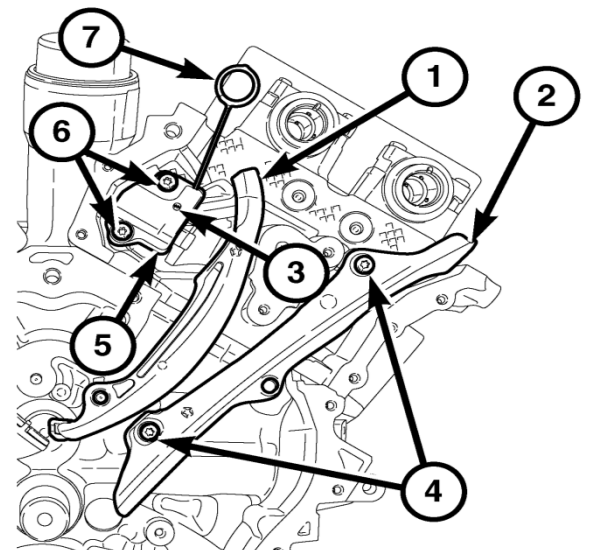

- 1 Drape the left side cam chain over the left side intake cam phaser and onto the idler sprocket (1) so that the arrow (3) is aligned with the plated link (2) on the cam chain.

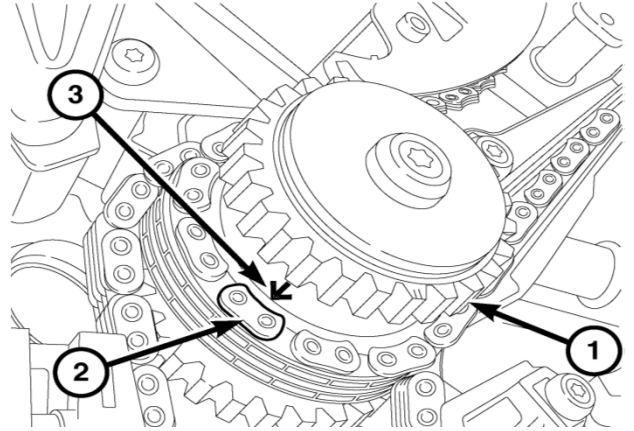

- 2 While maintaining this alignment, route the cam chain around the exhaust and intake cam phasers so that the plated links are aligned with the phaser timing marks (1). Position the left side cam phasers so that the arrows (3) point toward each other and are parallel to the cylinder head cover mounting surface (5). Press the exhaust cam phaser onto the exhaust cam, install and hand tighten the oil control valve (2).

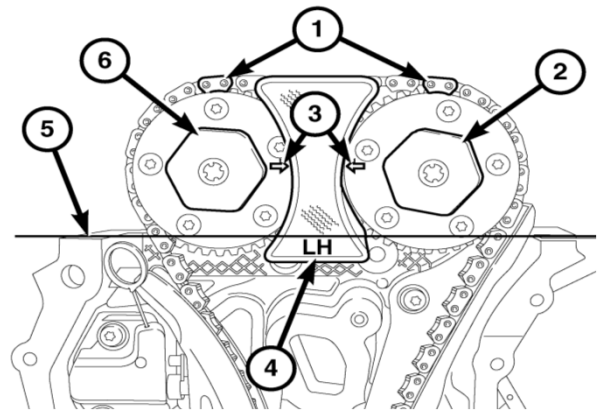

- 3 Drape the right side cam chain over the right side exhaust cam phaser and onto the idler sprocket (1) so that the dimple (2) is aligned with the plated link (3) on the cam chain.

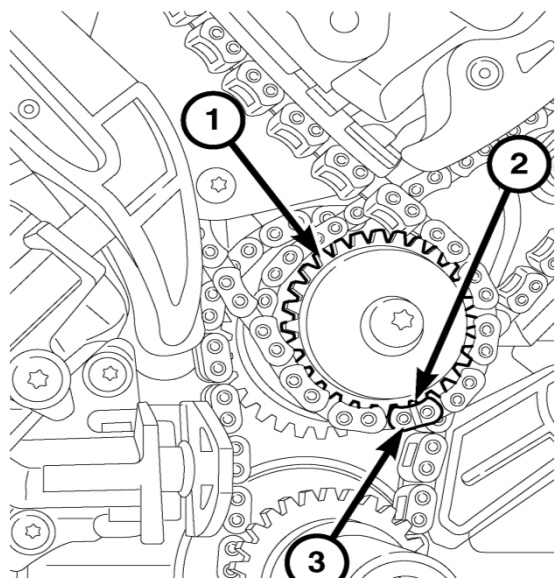

4 While maintaining this alignment, route the cam chain around the exhaust and intake cam phasers so that the plated links are aligned with the phaser timing marks (1). Position the right side cam phasers so that the arrows (3) point away from each other and the scribe lines (4) are parallel to the cylinder head cover mounting surface (6). Press the intake cam phaser onto the intake cam, install and hand tighten the oil control valve (2).

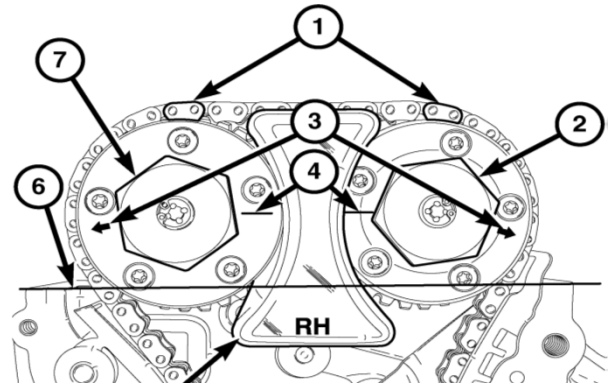

5 Tighten all four oil control valves to 150 N·m (110 ft. lbs.).

**Do Not Tighten Oil Control Valves without Phaser Locks in position.**

6 Remove all phaser locks and tensioner lock pins.

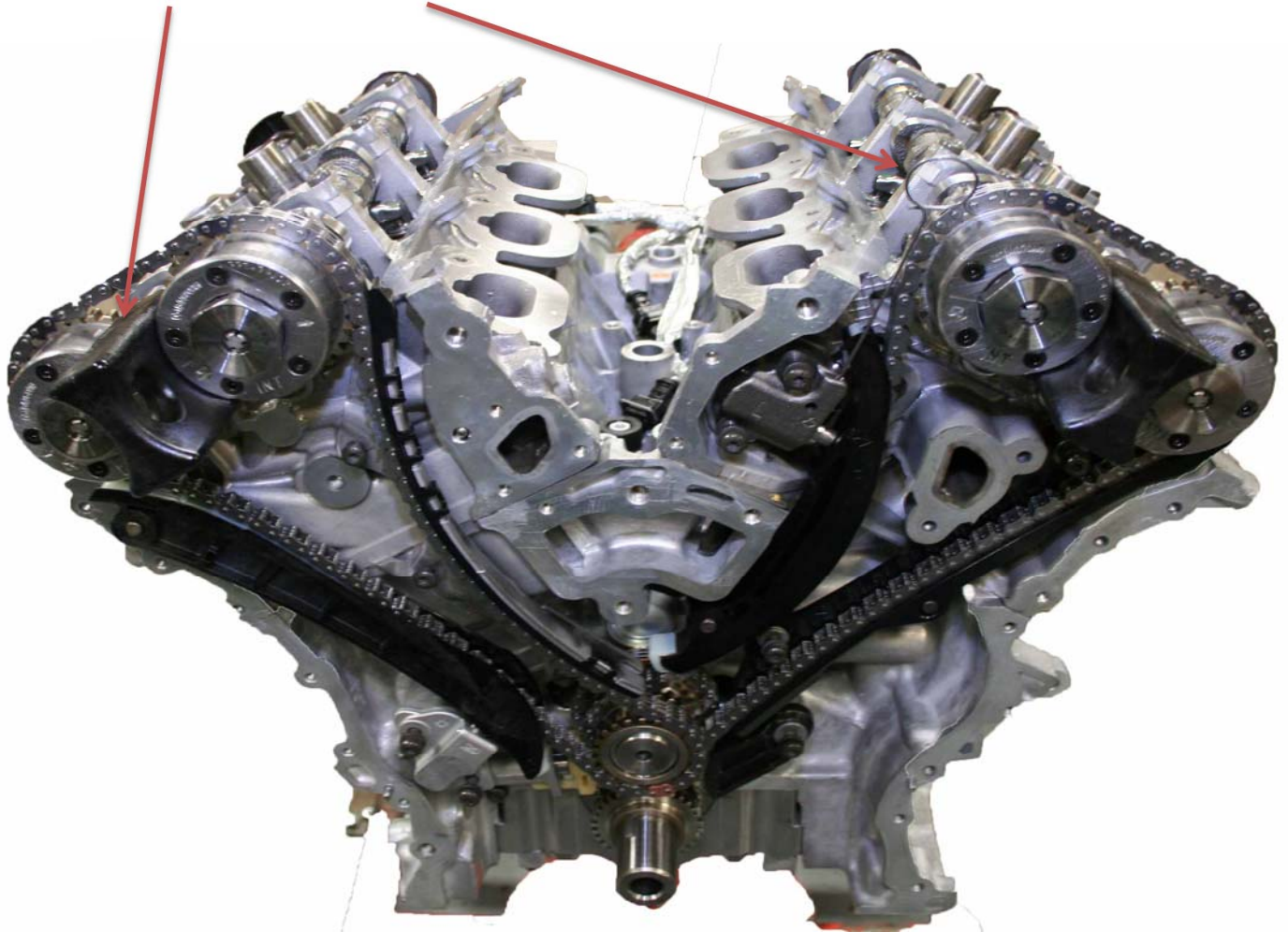

- 1 Install the windage tray with eight main bearing cap bolts. Tighten the bolts in the sequence shown to 21 N·m (16 ft. lbs.) plus 90°.

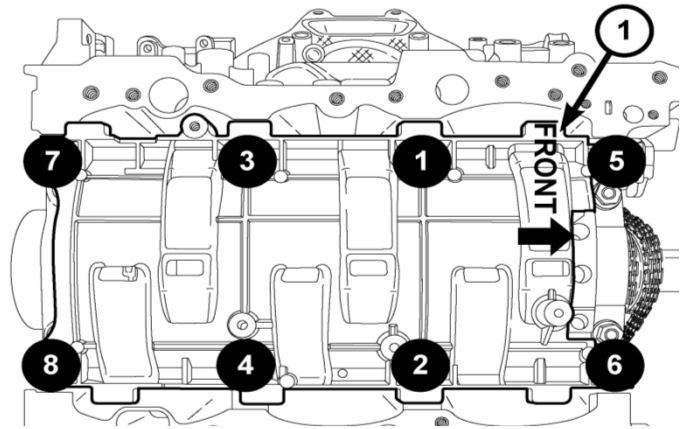

- 2 Align the locator pins (2) to the engine block and install the oil pump (3) with four bolts (1). Tighten the bolts to 12N·m (106 in. lbs.).

- 3 Install the oil pump chain tensioner on the oil pump.

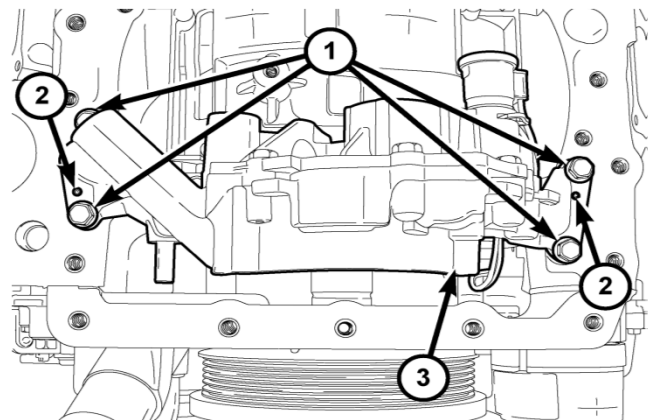

- 4 Position the oil pump chain tensioner spring (1) above the dowel pin (2).

- 5 Push back the oil pump chain tensioner and insert a suitable retaining pin (3) such as a 3 mm Allen wrench.

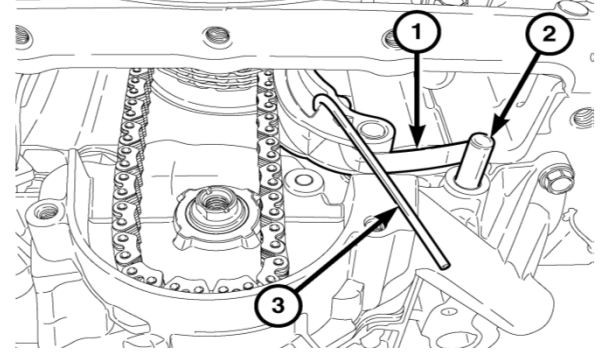

- 6 Place the oil pump sprocket (4) into the oil pump chain (3). Align the oil pump sprocket with the oil pump shaft and install the sprocket. Install the T45 retaining bolt (2) and tighten to 25 N·m (18 ft. lbs.).

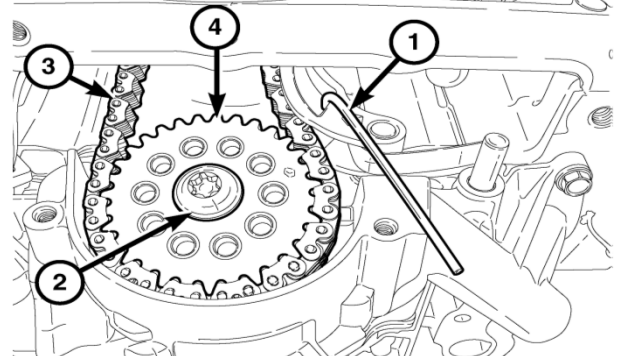

- 7 Remove the retaining pin (1). Verify that the oil pump chain is centered on the tensioner and crankshaft sprocket.

- 8 Rotate the crankshaft CW one complete revolution to verify proper oil pump chain installation.



Section 9  
Final Dress

Revision DRAFT	Final Dress RTV Sealant	Section	9
Jul-15		Sheet	1

**CAUTION:**

Do not use oil based liquids, wire brushes, abrasive wheels or metal scrapers to clean the engine gasket surfaces. Use only isopropyl (rubbing) alcohol, along with plastic or wooden scrapers. Improper gasket surface preparation may result in engine fluid leakage.

**CAUTION:**

Engine assembly requires the use of a unique sealant that is compatible with engine oil. Using a sealant other than Mopar Threebond Engine RTV Sealant may result in engine fluid leakage.

**CAUTION:**

Following the application of Mopar Threebond Engine RTV Sealant to the gasket surfaces, the components must be assembled within 20 minutes and the attaching fasteners must be tightened to specification within 45 minutes. Prolonged exposure to the air prior to assembly may result in engine fluid leakage.

68082860AA Mopar RTV Sealant



1 Remove all residual sealant from the timing chain cover, cylinder head and engine block mating surfaces (1), (2), (3), & (4).

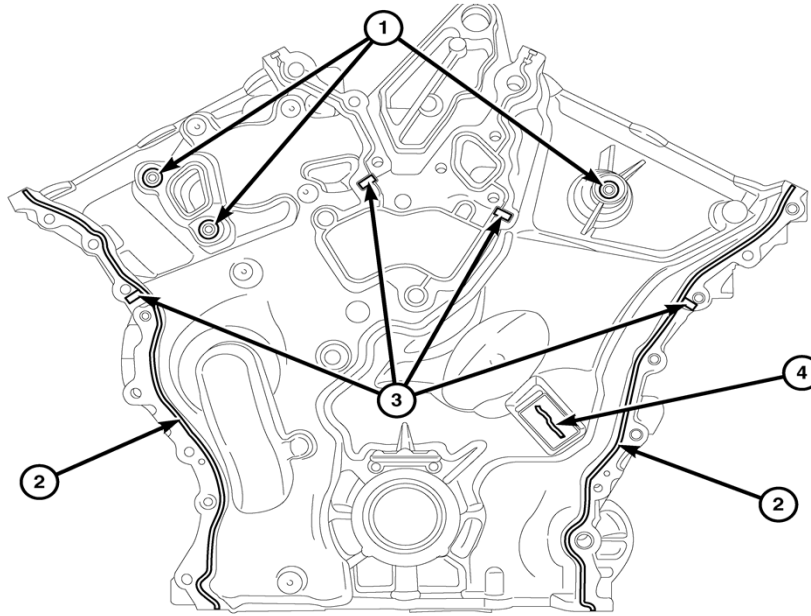

2 Inspect the coolant outlet housing gasket (1) and the water pump gasket (2). Replace if necessary.

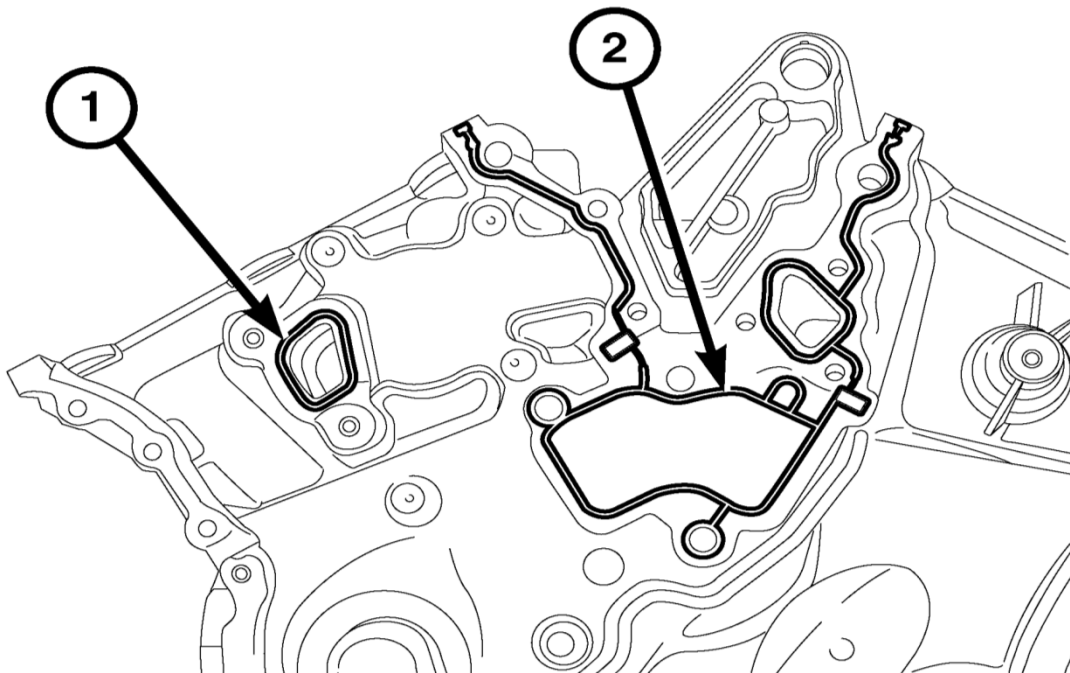

Revision DRAFT	Final Dress Front Cover	Section	9
Jul-15		Sheet	3

1 Clean the engine timing cover, cylinder head and block mating surfaces with isopropyl alcohol in preparation for sealant application.

2 Apply a 2 to 3 mm wide bead of Mopar Threebond Engine RTV Sealant to the front cover as shown in the following locations:

- Three cylinder head bosses (1)
- Right and left flanges (2)
- Four cylinder head to engine block T-joints (3)
- Cover to right cam chain tensioner gap (4)

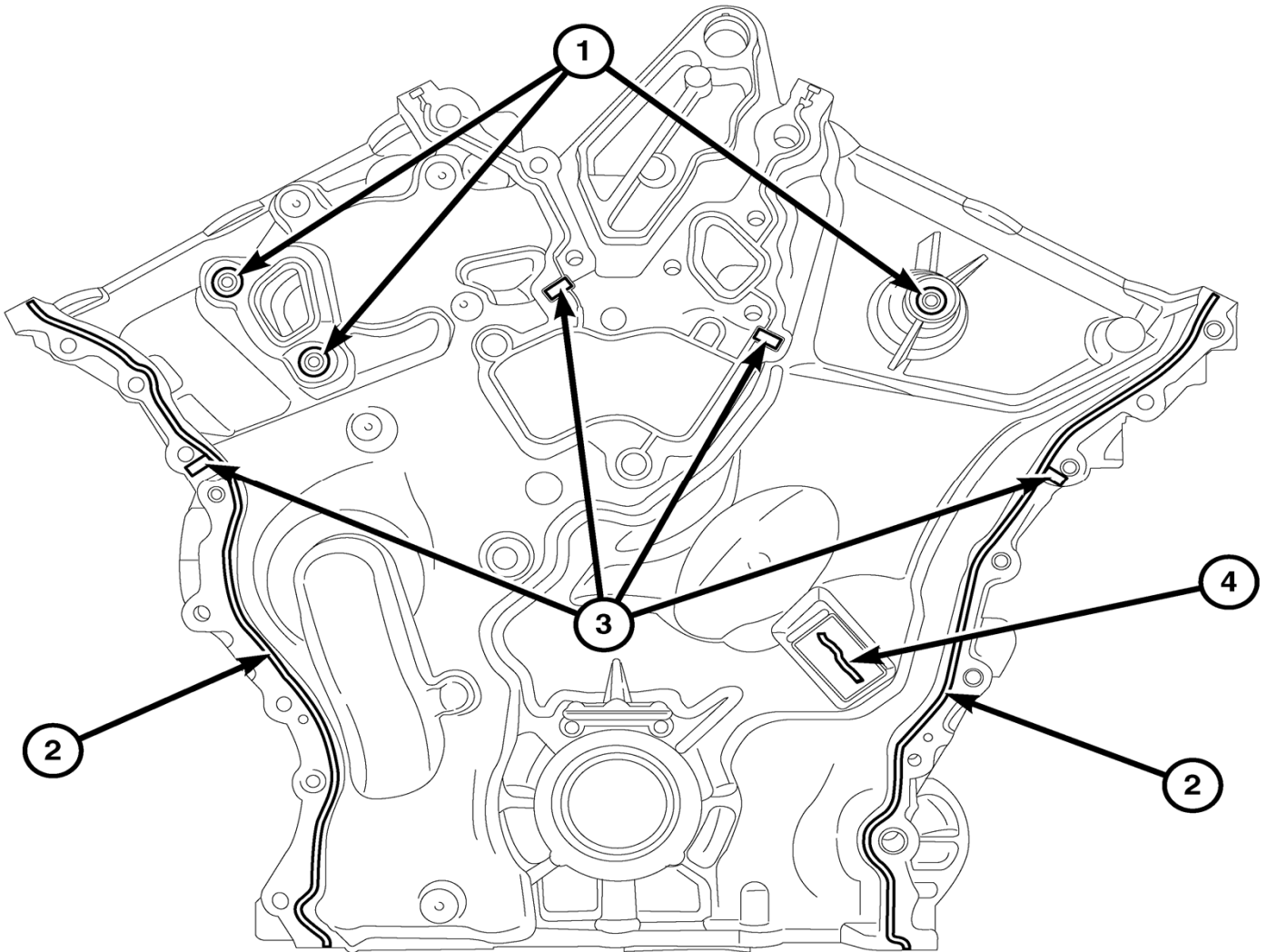

- 1 Align the locator pins (5) on the engine block to the engine timing cover and install the cover.
- 2 Install twenty-two M6 bolts (3) and one M8 bolt (4). Tighten the M6 bolts (3) to 12 N·m (106 in. lbs.) and the M8 bolt (4) to 25 N·m (18 ft. lbs.).

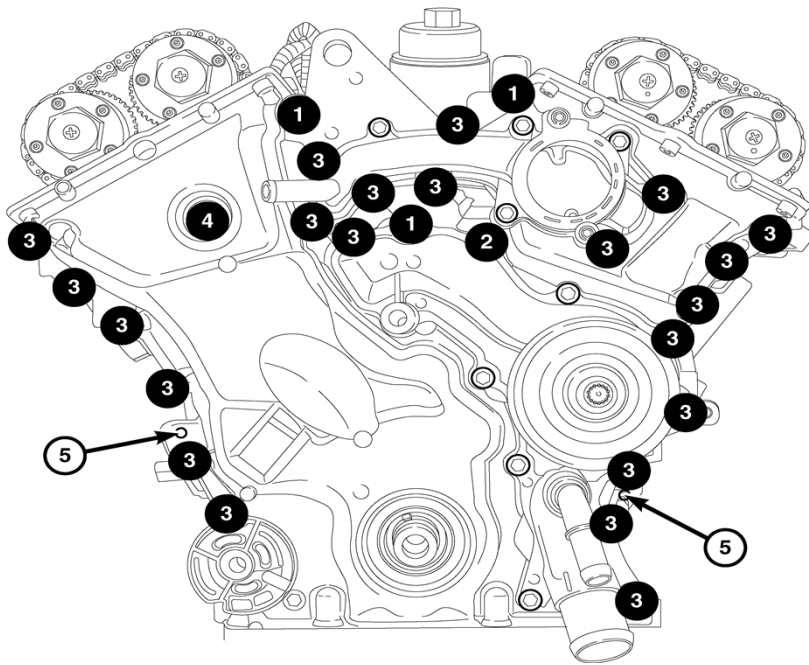

- OHT3H-302-1 CROSSOVER, COOLANT
- OHT3H-303-1 CONNECTOR, COOLANT CROSSOVER
- OHT3H-300-1 PUMP, WATER, MODIFIED
- OHT3H-304-2 PAN, OIL MODIFIED, ASSY.  
(Upper, Lower, Dipstick)

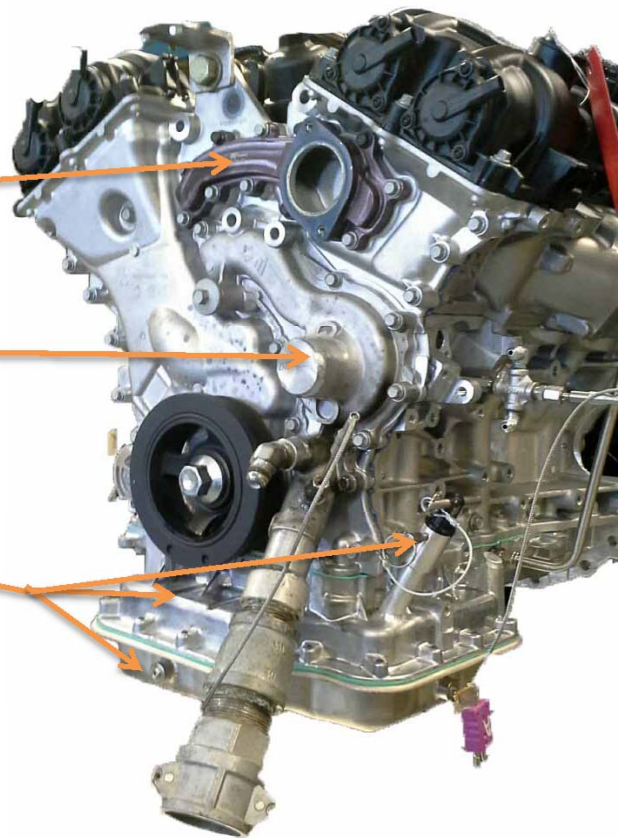

Revision DRAFT	Final Dress Upper Oil Pan	Section	9
Jul-15		Sheet	5

- 1 Clean all sealing areas of the engine block and front and rear covers in preparation for the upper oil pan installation.
- 2 Apply a 2 to 3 mm wide bead of Mopar Threebond Engine RTV Sealant to the joints between the engine block and the front and rear covers.
- 3 Install OHT3H 304-19 Upper Oil Pan Gasket to engine.

RTV Sealant (4) places

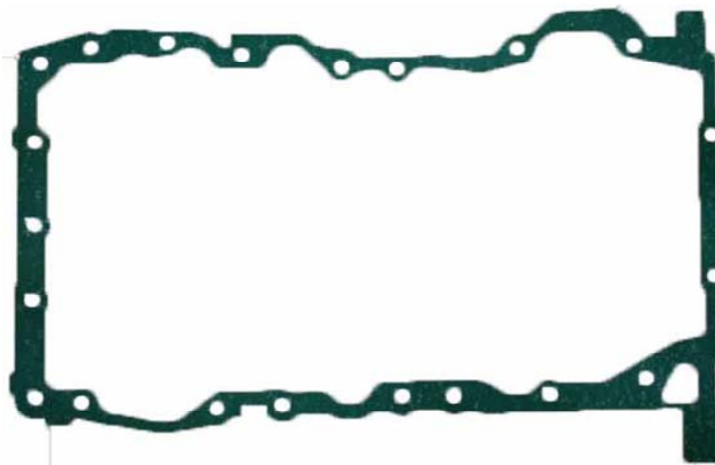
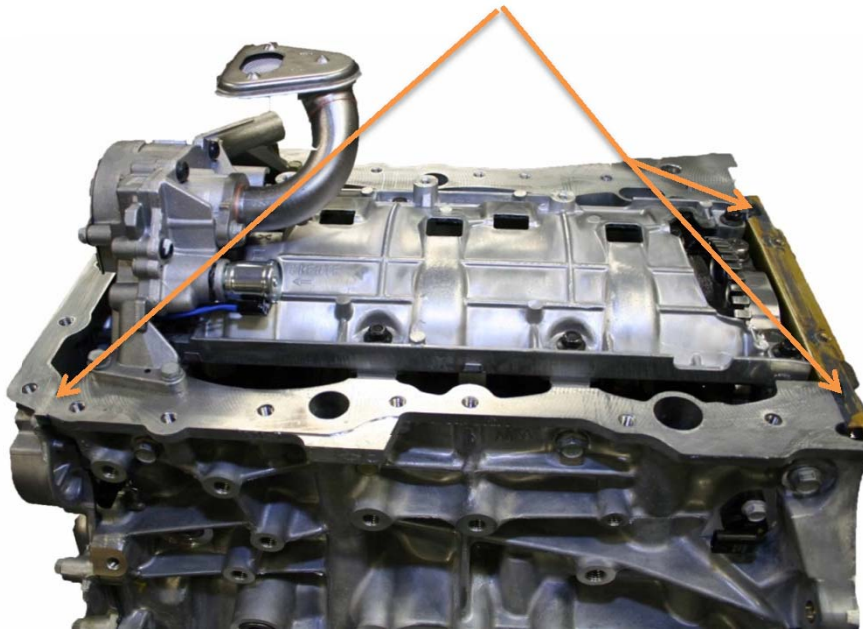

OHT3H-304-19 Upper Oil Pan Gasket

Note: Gasket view in photo is 180° rotated from view of engine

Revision DRAFT	Final Dress Upper Oil Pan	Section	9
Jul-15		Sheet	6

**CAUTION:**

Make sure that the rear face of the oil pan is flush to the transmission bell housing before tightening any of the oil pan mounting bolts. A gap between the oil pan and the rear mount could crack the oil pan casting.

- 1 Install the oil pan to the engine block flush to the transmission bell housing. Secure the oil pan to the engine block with nineteen M8 oil pan mounting bolts (1) finger tight.
- 2 Tighten the nineteen previously installed M8 oil pan mounting bolts to 25 N·m (18 ft. lbs.).

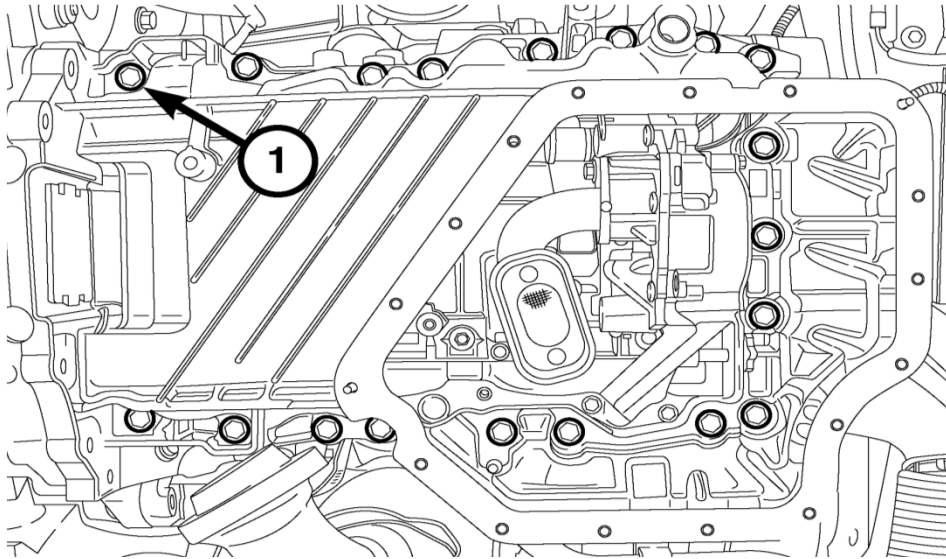

View is shown with transmission attached in vehicle

- 3 Install the two M6 bolts (1) to the rear oil seal retainer flange and tighten to 12 N·m (9 ft. lbs.).

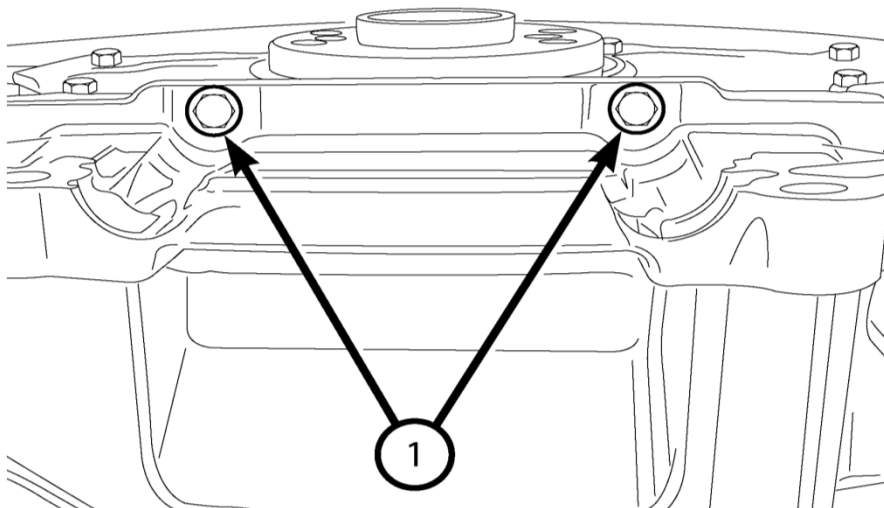

Revision DRAFT	Final Dress Lower Oil Pan	Section	9
Jul-15		Sheet	7

- 1 Clean the upper and lower oil pan mating surfaces in preparation of installation of the lower oil pan.
- 2 Install OHT 3H 304-18 lower oil pan gasket,
- 3 Install the lower oil pan to the upper oil pan with fifteen bolts (1) and tighten to 11 N·m (97 in. lbs.).





Revision DRAFT	Final Dress Camshaft Covers	Section	9
Jul-15		Sheet	8

**CAUTION:**

Do not use oil based liquids, wire brushes, abrasive wheels or metal scrapers to clean the engine gasket surfaces. Use only isopropyl (rubbing) alcohol, along with plastic or wooden scrapers. Improper gasket surface preparation may result in engine fluid leakage.

**CAUTION:**

The magnetic timing wheels (1) must not come in contact with magnets (pickup tools, trays, etc.) or any other strong magnetic field. This will destroy the timing wheels ability to correctly relay camshaft position to the camshaft position sensor.

- 1 Remove all residual sealant (1) from the cylinder head, timing chain cover and cylinder head cover mating surfaces
- 2 Apply a 2 to 3 mm wide bead of Mopar Threebond Engine RTV Sealant (1) to the two engine timing cover to cylinder head T-joints as shown.
- 3 Align the locator pins (1) to the cylinder head and install the cylinder head cover.
- 4 Tighten the cylinder head cover bolts and double ended studs in the sequence shown to 12 N·m (106 in. lbs.).

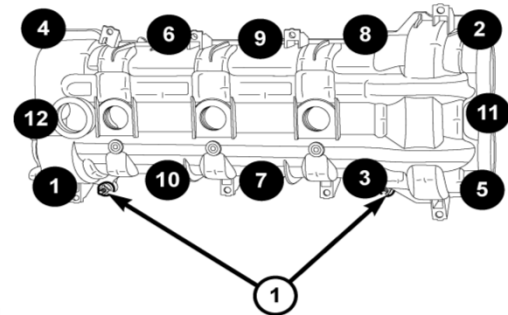
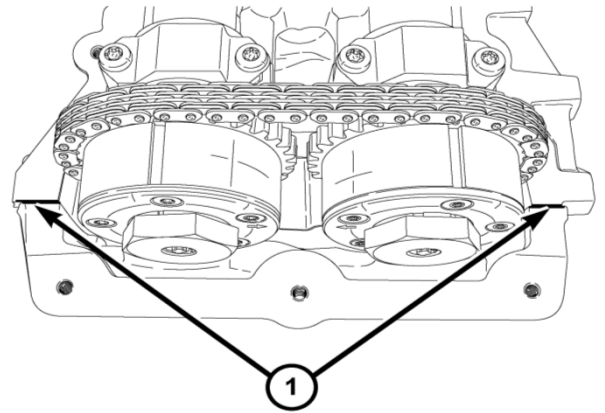
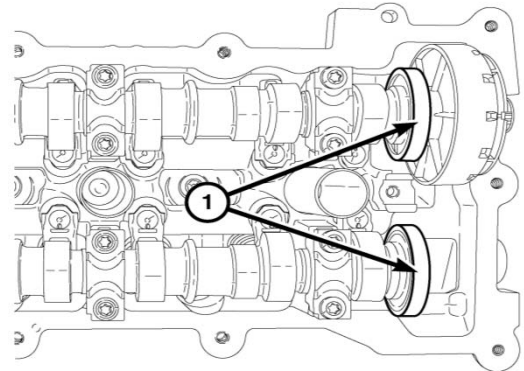

Revision DRAFT	Final Dress PCV Valve	Section	9
Jul-15		Sheet	9

The Crankcase Ventilation Valve must be modified for test. Using a M12 1.75 Tap threaded into the bushing about 4 threads, that holds the Valve, Spring, and Washer inside the PCV Housing. Clamp the tap into a vise and lightly tap on the housing with a plastic mallet to pull the bushing out and remove the insides.



1 Install the empty PCV Housing (1) in the rear of the right camshaft cover aligning the inner lip seal with the right side exhaust camshaft and fasten using the three fasteners (2)

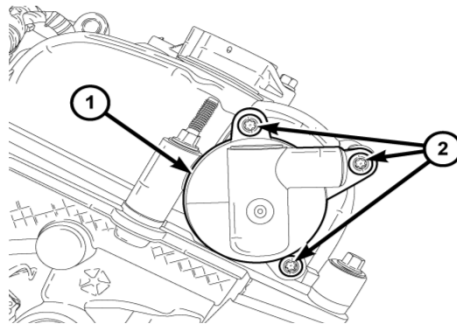

Revision DRAFT	Final Dress Cam Sensors / Coils	Section	9
Jul-15		Sheet	10

1 Install both the left and right camshaft position sensors.

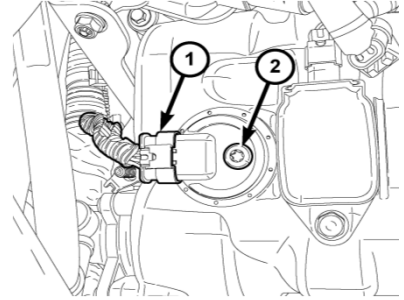

**NOTE:**

Spark Plugs and Ignition Coils may be installed at the test stand.

2 Install the spark plugs and ignition coils.

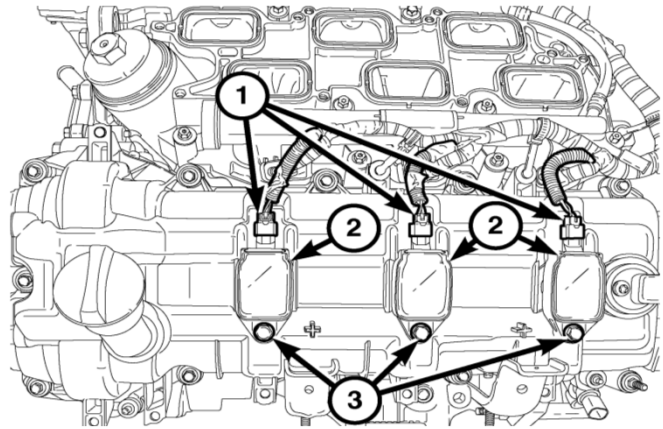

3 If removed, Install the variable valve timing solenoids.

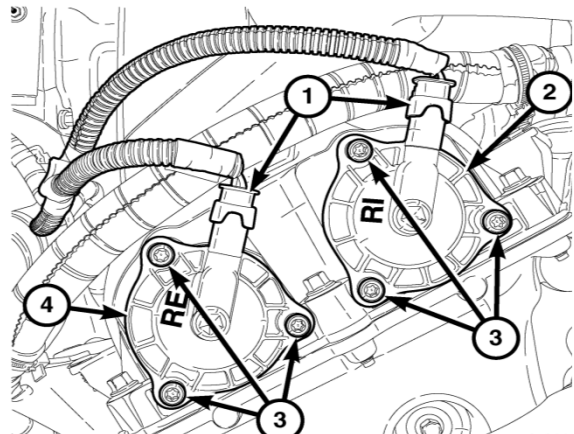

**Note: Ensure proper main oil gallery thermocouple is installed before installing oil filter assembly**

**See Section 7 Sheet 5 for direction**

1 Install the O-ring seals for the oil cooler to the oil filter / cooler housing. (Non Serviced Parts)

2 Assembly cleaned oil cooler to housing using six (6) Torx Head Screws torqued to 12 N·m (106 in. lbs.)

3 Lightly lubricate the O-ring on a new oil filter element with EF-411 and install the element into the oil filter housing.

4 Lightly lubricate the O-ring for the oil filter element cap with EF-411 and install on the oil filter housing.

5 Install new oil filter housing seals (1)&(2) onto the oil filter housing.

68191356AA Kit, O-Ring, Oil filter Housing (5 pc.) items (1) & (2) in view

6 Position the oil filter housing (1) on the engine block.

7 Install five bolts and tighten in the sequence shown to 12 N·m (106 in. lbs.).

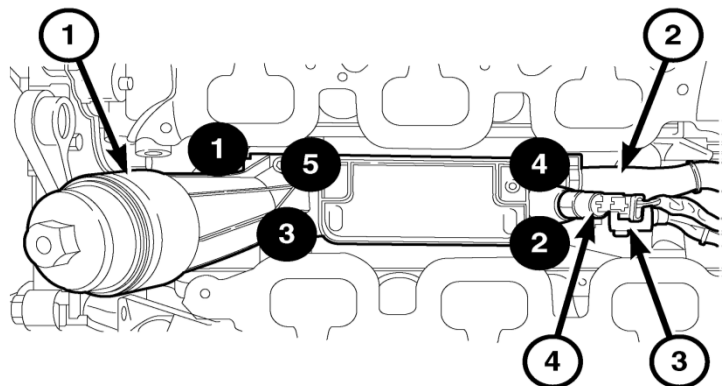
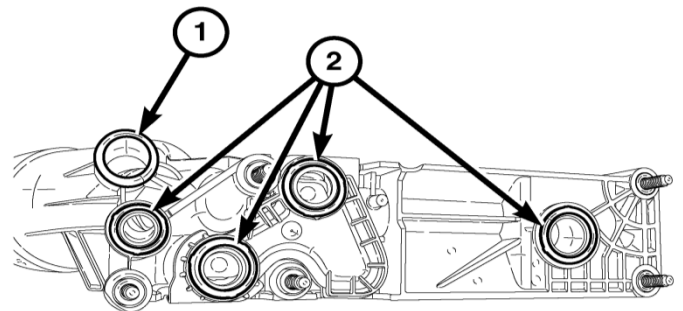

**Note:**

Labs must install the oil filter and charge the engine with test oil before starting engine.

**Note: Oil Filter must be 2014 or newer to seal properly in adapter housing.**

04893383AB Filter, Oil

68191349AB Filter, Oil, with O-Ring

Revision DRAFT	Final Dress Lower Intake	Section	9
Jul-15		Sheet	12

**Note: Ensure proper main oil gallery thermocouple is installed before installing lower intake assembly**

**See Section 7 Sheet 5 for direction**

- 1 Check the lower intake manifold assembly to ensure the fuel rail and injectors are installed and the seals are all in tact and clean. Ensure there are no debris inside the inlet ports on the cylinder heads and lower intake assembly.
- 2 Position the lower intake manifold (1) on the cylinder head surfaces
- 3 Install the manifold attaching bolts and tighten in the sequence shown to 8 N·m (71 in. lbs.).

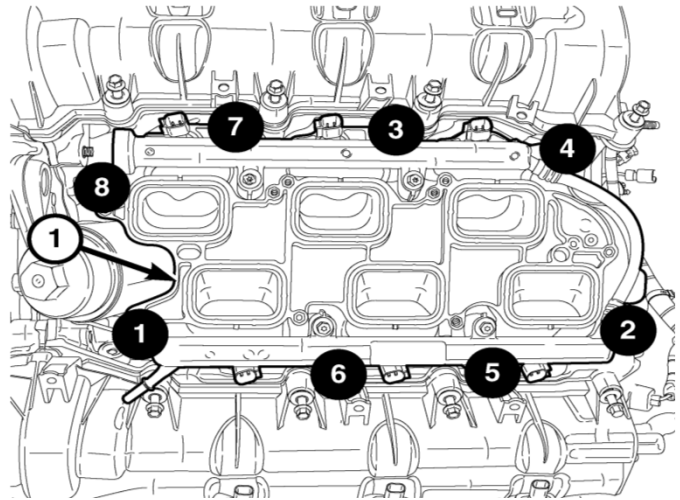

- 4 Cover the inlet ports with tape or install the upper intake assembly depending on lab practices.
- 5 Install the upper intake manifold (1), support brackets and resonator leaving the insulated pad out ( the insulated pad for NVH is not used in testing).

**CAUTION:**

The upper intake manifold fasteners are screw type and self thread into the lower intake. Operators and build technicians must exercise care during tightening. If the fasteners are striped, a new lower intake must be used.

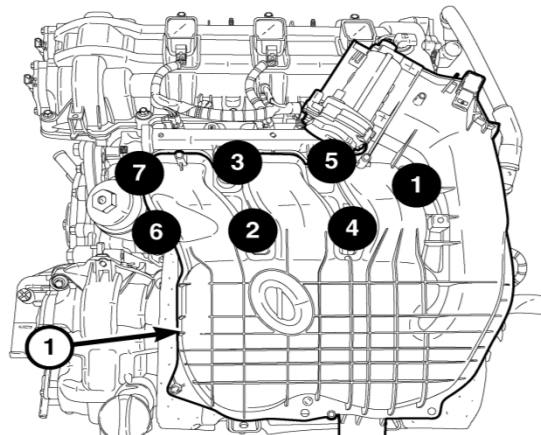

Section 10  
OHT Hardware

Revision DRAFT	OH Technologies	Section	10
Jul-15		Sheet	1

3H303-4	O-RING, CONNECTOR, COOLANT CROSSOVER, SEQ. IIIH
3H304-03	PLUG, OIL, DRAIN, SEQ. IIIH
3H304-11	DISPTICK, ASSEMBLY, SEQ. IIIH
3H304-18	GASKET, LOWER, PAN, OIL, IIIH (REV. A), SEQ. IIIH
3H304-19	GASKET, UPPER, PAN, OIL, SEQ. IIIH
OHT3H-001-1	PENTASTAR INTAKE PHASER (FIXED AT 110°, LESS HOLES DRILLED IN ROTOR)
OHT3H-002-1	PENTASTAR EXHUAST PHASER (FIXED AT 112°, LESS HOLES DRILLED IN ROTOR)
OHT3H-004-1	JUMPER, HARNESS, THROTTLE CONTOL, SEQ. IIIH
OHT3H-005-1	HARNESS, DYNO, SPECIAL TEST, SEQ. IIIH
OHT3H-070-1	PISTON, SPECIAL TEST, SEQ. IIIH
OHT3H-071-1	PIN, WRIST (FOR USE WITH OHT3H-070-1), SEQ. IIIH
OHT3H-072-1	CLIP, PIN, WRIST (CIRCLIPS), SEQ. IIIH
OHT3H-075-1	6,000 ML 0 ERLENMEYER FLASK, AMBER FILLED, ETCHED RING @ 5920 ML. CALIBRATED TO CONTAIN USING CLASS A STANDARDS
OHT3H-300-1	PUMP, WATER, MODIFIED , SEQ. IIIH
OHT3H-302-1	CROSSOVER, COOLANT, CHRYSLER IIIH
OHT3H-303-1	CONNECTOR, COOLANT CROSSOVER, SEQ. IIIH
OHT3H-304-2	PAN, OIL MODIFIED, ASSY. (INCLUDING DIPSTICK, UPPER AND LOWER SECTIONS), SEQ. IIIH
OHT3H-96040-1	RINGS, SPECIAL TEST, ENGINE SET (SEQ. IIIH)

Revision DRAFT	OH Technologies	Section	10
Jul-15		Sheet	2



OHT3H-300-1 Pump, Water, Modified



OHT3H-302-1 Crossover, Coolant



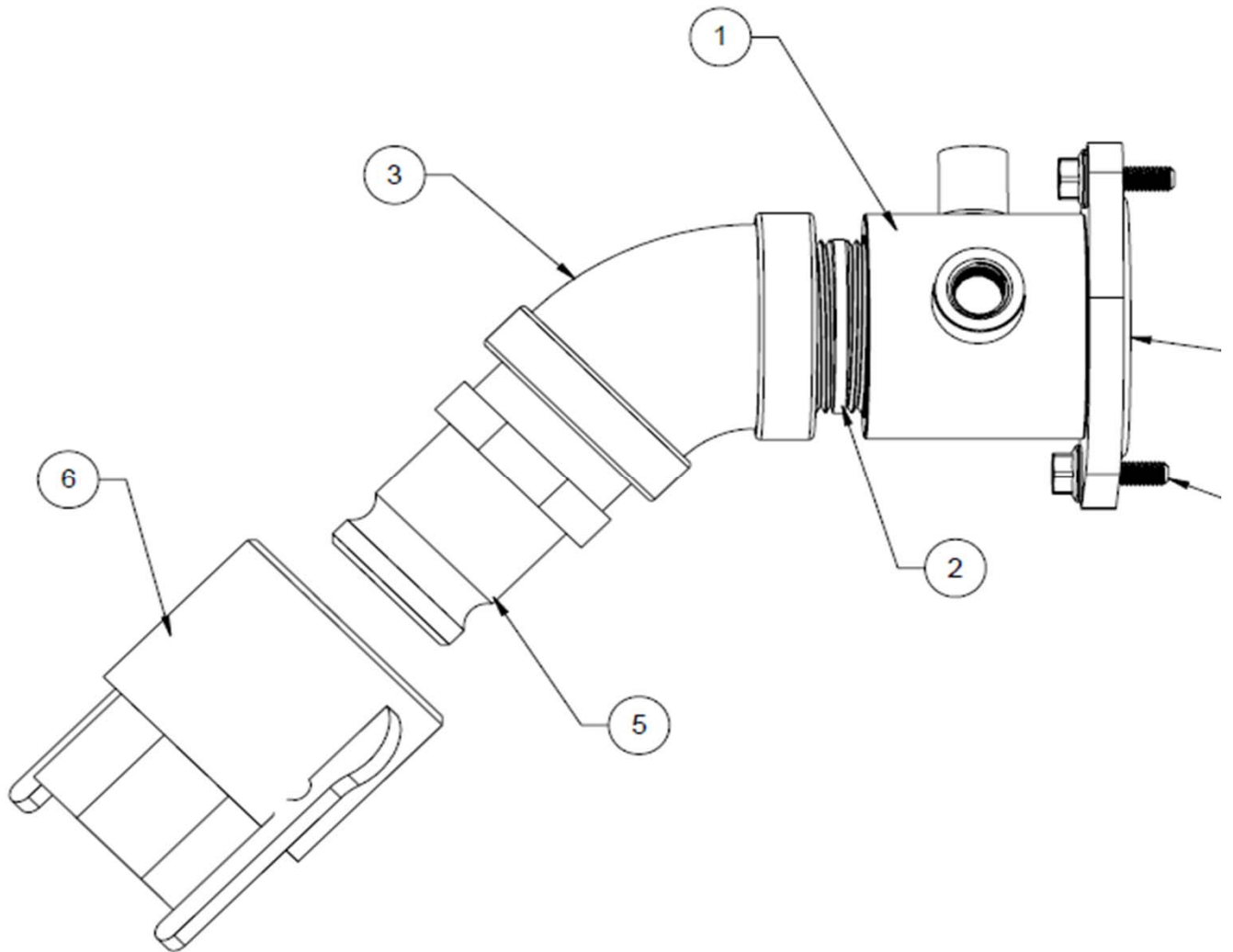

OHT3H-303-1 Revision B - Adapter, Coolant Crossover with Couplings  
Comes as an assembly - items 1 - 6

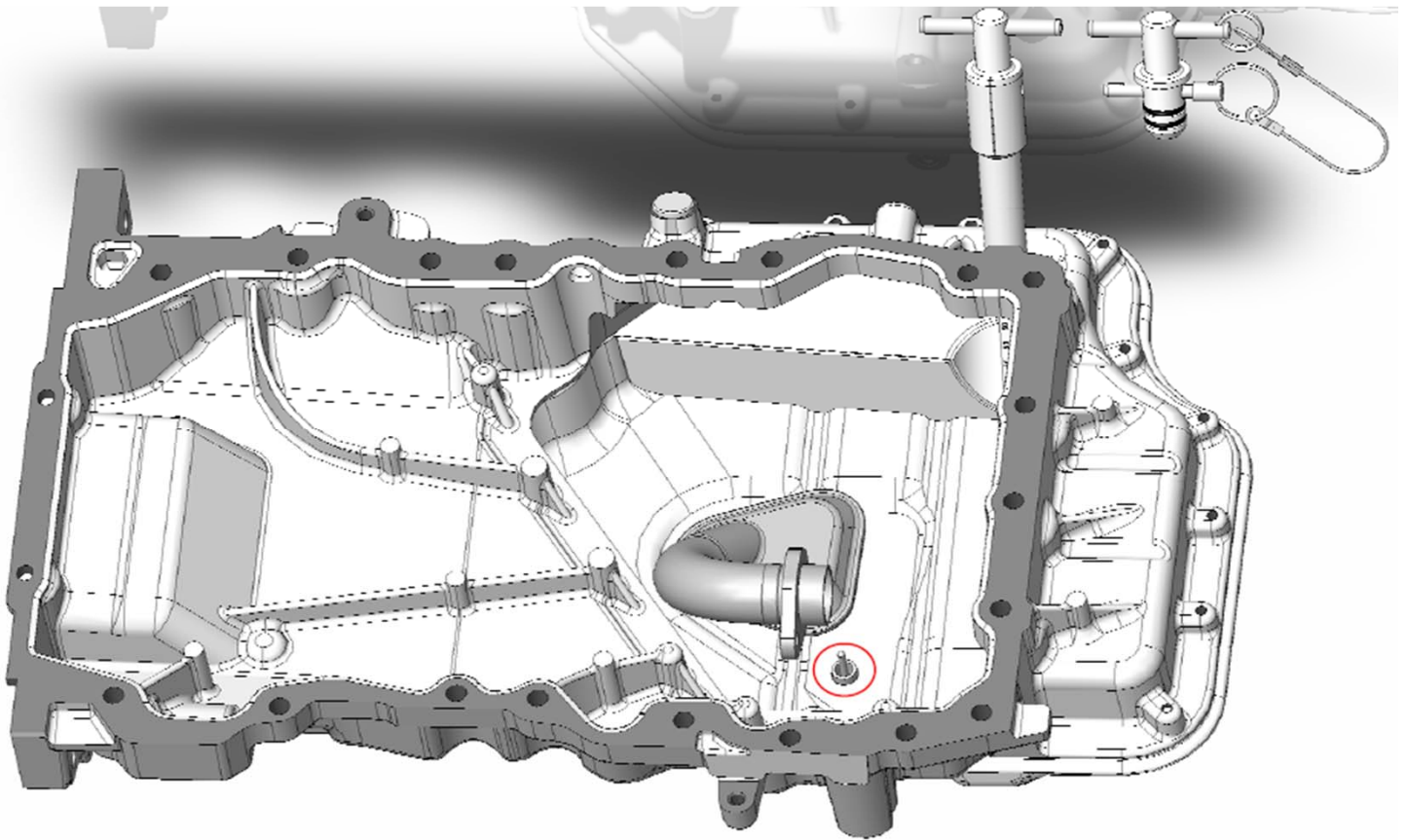

OHT3H-304-2 Pan, Oil, Modified



Revision DRAFT
Jul-15

# OH Technologies

Section	10
Sheet	5

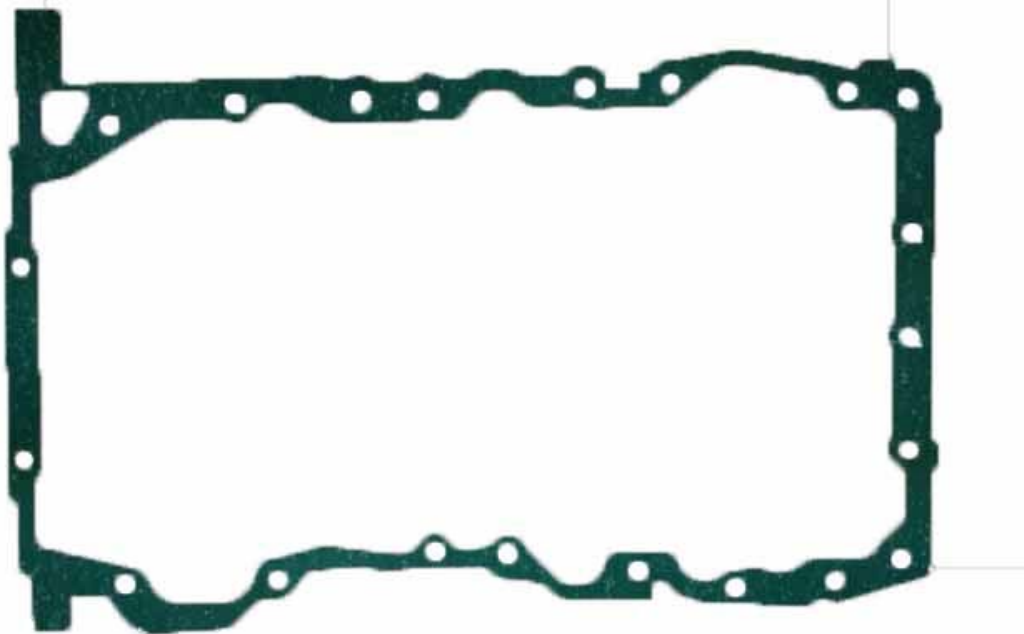

OHT3H-304-19 Gasket, Pan, Oil, Upper

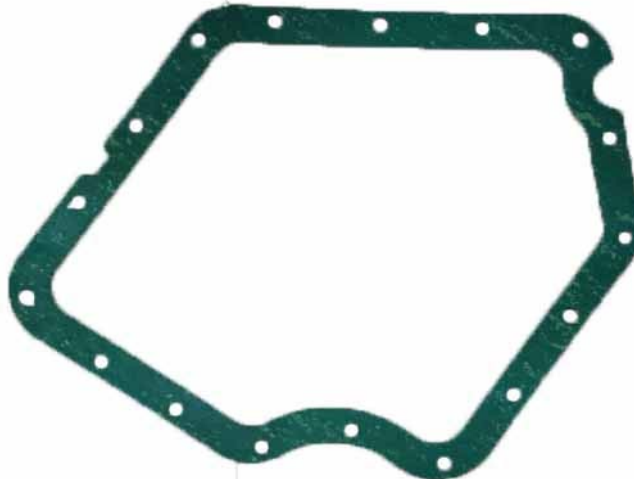

OHT3H-304-18 Gasket, Pan, Oil, Lower



OHT3H-070-1 Piston, IIIH, Special

OHT3H-96040-1

RINGS, SPECIAL TEST, ENGINE SET (SEQ. IIIH)



Top



Second



Rail



Expander

Section 11  
Reagents and Equipment

## Chrysler Sequence IIIH Oxidation & Deposit Test

### Reagents

#### Engine Assembly Lubricant:

- EF-411, Engine Assembly Lubricant, supplied through ExxonMobil

#### Engine Coolant:

- ShellZone Dex-Cool® Extended Life antifreeze/coolant concentrate (product code 94040)
- ShellZone Dex-Cool Extended Life antifreeze/coolant premix which is a mixture of ShellZone Dex-Cool antifreeze/coolant and deionized water (product code 94070).

#### Engine Degreasing Solvent:

- Mineral Spirits meeting ASTM Specification D 235 Type II Class C Specifications.

#### Ultra Sonic Cleaner Chemicals:

- Ultrasonic B Degreaser
- Ultrasonic 7 Soap

#### Sunnen Equipment:

- Sunnen Honing Fluid SHO-965

#### Sealants:

- Mopar, Engine RTV Sealant part number 68082860AA
- Loctite, 545, Thread Sealant, Anaerobic
- Loctite, 567, Thread Sealant, Low Strength, Anaerobic
- Loctite, 648, Retaining Compound, Anaerobic
- Loctite, Gasket Sealant 2, (Permatex #2), slow dry flexible cure, oil resistant
- Teflon Tape

## Chrysler IIIH Oxidation & Deposit Test

### Special Test Equipment

#### Sunnen Equipment:

- Model SV-10 Honing Machine
- Honing Stones:
- Course Stone, DHH6GMH85
- Plateau Brush, DHHB6534, (DHHB7534 Alternate Substitute)
- Honing Fluid SHO-965005 (55 gal.) SHO965005 (5 gal.)
- Honing Filter PF105

#### Mitutoyo:

- Surf-test SJ-410
- Deep Groove Stylus (5 $\mu$ m tip) 12AAB-409
- Skid Nose Piece 12AAC755
- 50 mm Extension 12AAG202

#### BHJ:

- Cylinder Block Honing Torque Plates, MP-3.6PSV6-R-AL-T-DID

#### IMTS:

- Chrysler IIIH Thermocouple Tapping Fixture Assembly 151132-F001

#### Tierra Tech Ultra Sonic Parts Cleaner:

- Tierra Tech MOT-500NS Ultra Sonic Cleaner, (or equivalent model)
- Ultrasonic B Degreaser
- Ultrasonic 7 Soap

#### Starrett:

- Starrett No270 Tapered Gage

Section 12  
Document Update Timeline