

Revision DRAFT	<b>Chrysler IIIH Engine Specifications</b>	Section	1
Jan-15		Sheet	1

Description	Specification
-------------	---------------

### General Information

Engine Family	60° DOHC V-6 24 Valve	
Compression Ratio	10.2 : 1	
Lead Cylinder	#1 Right Bank	
Firing Order	1-2-3-4-5-6	
	Metric	Standard
Displacement	3.6 Liters	220 Cubic Inches
Bore and Stroke	96.0 x 83.0 mm	3.779 x 3.268 in.

Cylinder Block	Metric	Standard
Cylinder Bore Diameter (Test)		
Cylinder Bore Out-of-Round (Max.)	0.009 mm	0.00035 in.
Cylinder Bore Cylindricity	0.014 mm	0.0006 in.

Pistons	Metric	Standard
Piston Diameter (Metal to Metal)		
Clearance at Size Location (Metal to Metal)	0.030 - 0.050 mm	0.0012 - 0.002 in.
Clearance at Size Location (Metal to Coating)	0.010 - 0.030 mm	0.0004 - 0.0012 in.
Piston Pin Offset	0.8 mm	0.031 in.
Piston Ring Groove Diameter No. 1	88.24 - 88.44 mm	3.474 - 3.482 in.
Piston Ring Groove Diameter No. 2	86.54 - 86.74 mm	3.407 - 3.415 in.
Piston Ring Groove Diameter No. 3	89.16 - 89.36 mm	3.510 - 3.518 in.
Piston Pin Diameter	21.9985 ± 0.0015 mm	0.86608 ± 0.00006 in.
Piston Pin Clearance in Piston	0.002 - 0.011 mm	0.0001 - 0.0004 in.
Piston Pin Clearance in Rod	0.011 - 0.024 mm	0.0004 - 0.0009 in.

Piston Rings	Metric	Standard
Ring Gap Top		
Ring Gap Second		
Ring Gap Oil Control Rails	0.15 - 0.66 mm	0.006 - 0.026 in.

Piston Ring Side Clearance	Metric	Standard
Top	0.025 - 0.083 mm	0.0010 - 0.0033 in.
Second	0.030 - 0.078 mm	0.0012 - 0.0031 in.
Oil Control Assembly	0.007 - 0.173 mm	0.0003 - 0.0068 in.

Piston Ring Width	Metric	Standard
Top	3.00 - 3.20 mm	0.118 - 0.126 in.
Second	3.59 - 3.85 mm	0.141 - 0.152 in.
Oil Control Rails	1.930 - 2.083 mm	0.076 - 0.082 in.

<b>Revision DRAFT</b>	<b>Chrysler IIIH Engine Specifications</b>	<b>Section</b>	<b>1</b>
<b>Jan-15</b>		<b>Sheet</b>	<b>2</b>

Description	Specification	
<b>Connecting Rods</b>	Metric	Standard
Bearing Clearance (With Crush)	0.023 - 0.064 mm	0.0009 - 0.0025 in.
Side Clearance	0.070 - 0.370 mm	0.0028 - 0.0146 in.
Piston Pin Bore Diameter	22.016 ± 0.005 mm	0.8668 ± 0.0002 in.
Bearing Bore Out of Round (Max.)	0.008 mm	0.0003 in.

<b>Crankshaft Main Bearing Journals</b>	Metric	Standard
Diameter	71.996 ± 0.009 mm	2.8345 ± 0.0035 in.
Bearing Clearance	0.024 - 0.050 mm	0.0009 - 0.0020 in.
Out of Round (Max.)	0.005 mm	0.0002 in.
Crankshaft End Play	0.050 - 0.290 mm	0.002 - 0.0114 in.

<b>Crankshaft Rod Bearing Journals</b>	Metric	Standard
Diameter	59.0 ± 0.009 mm	2.3228 ± 0.0035 in.
Bearing Clearance	0.023 - 0.064 mm	0.0009 - 0.0025 in.
Out of Round (Max.)	0.005 mm	0.0002 in.

<b>Camshaft Journal Dia. &amp; Clearance</b>	Metric	Standard
Bore Dia. Cam Tower No. 1	32.020 - 32.041 mm	1.2606 - 1.2615 in.
Bore Dia. Cam Towers No. 2, 3, 4	24.020 - 24.041 mm	0.9457 - 0.9465 in.
Journal Dia. No 1	31.976 - 31.995 mm	1.2589 - 1.2596 in.
Journal Dia. No. 2, 3, 4	23.977 - 23.996 mm	0.9440 - 0.9447 in.
Clearance No. 1	0.025 - 0.065 mm	0.001 - 0.0026 in.
Clearance No. 2, 3, 4	0.024 - 0.064 mm	0.0009 - 0.0025 in.
Camshaft End Play	0.075 - 0.251 mm	0.003 - 0.010 in.

<b>Cylinder Head</b>	Metric	Standard
Compressed Gasket Thickness @ Fire Ring	0.48 - 0.60 mm	0.019 - 0.024 in.
Cylinder Head Deck Flatness	0.09 mm	0.0035 in.
Valve Seat Angle	44.75° ± 0.25° from the valve guide axis	
Intake Valve Seat Width	1.0 - 1.2 mm	0.04 - 0.05 in.
Exhaust Valve Seat Width	1.41 - 1.61 mm	0.055 - 0.063 in.
Valve Guide Bore Diameter	6.00 - 6.02 mm	0.236 - 0.237 in.
Valve Stem to Guide Clearance (Intake)	0.023 - 0.061 mm	0.0009 - 0.0024 in.
Valve Stem to Guide Clearance (Exhaust)	0.030 - 0.068 mm	0.0012 - 0.0027 in.

Revision DRAFT	Chrysler IIIH Torque Specifications		Section	1
15-Jan			Sheet	3
	N·m	Lb. Ft.	Lb. In.	
Camshaft Chain Tensioner (Primary) M6 T30	12		106	
Camshaft Chain Guide (Primary) M6 T30	12		106	
Camshaft Chain Idler Sprocket M8 T45	26	18		
Camshaft Chain LH Tensioner (Secondary) M6 T30	12		106	
Camshaft Chain LH Guide (Secondary) M6 T30	12		106	
Camshaft Chain RH Tensioner (Secondary) M6 T30	12		106	
Camshaft Chain RH Guide (Secondary) M6 T30	12		106	
Camshaft Position (CMP) Sensor to Cylinder Head M6 T30	9		80	
Camshaft Bearing Cap M6 T30	10		84	
Connecting Rod Cap M9 Bolt	20 + 90°	15 + 90°		
Coolant Pump Plate to Engine Timing Cover M6 Bolt	11		97	
Coolant Crossover Plate to Engine Timing Cover M6 Bolt	11		97	
Coolant Pump Plate to Engine Timing Cover M10 Bolt	55	40		
Crankshaft Target Wheel to Counterweight M6 T30	11		97	
Crankshaft Outer Main Bearing Cap and Windage Tray M8 Bolt	21 + 90°	16 + 90°		
Crankshaft Inner main Bearing Cap M11 Bolt	20 + 90°	15 + 90°		
Crankshaft Side Main Bearing Cap (Tie Bolt) M8 Bolt	30		266	
Crankshaft Vibration Damper M16 Bolt	40 + 105°	30 + 105°		
Crankshaft Position (CKP) Sensor to Engine Block M6 Bolt	12		106	
Crankshaft Rear Oil Seal Retainer M6 T30	12		106	
Cylinder Head Oil Gallery Plug	18	9		
Cylinder Head Oil Restrictor M8 Plug	15		133	
Cylinder Head to Engine Block M12 in Sequence	See ASM Section 6 Sheet 4			
Cylinder Head / Camshaft Cover M6 Bolt	12		106	
Engine Coolant Temperature Sensor (ECT)	22	16		
Flywheel to Crankshaft M10 Bolt	95	70		
Fuel Rail to Lower Intake Manifold M6 Bolt	7		62	
Lower Oil Pan to Upper Oil Pan M6 Bolt	10.5		93	
Idler Pulley to Engine Timing Cover Accessory Drive M8 Bolt	12		106	
Ignition Capacitor to Cylinder Head M6 Bolt	10		89	
Ignition Coil to Cylinder Head Cover M6 Bolt	8		71	
Intake Manifold (Upper) M6 Bolt	10		89	
Intake Manifold (Lower) M6 Bolt	12		106	

Revision DRAFT	Chrysler IIIH Torque Specifications	Section		1
15-Jan		Sheet		4
Description	N·m	Lb. Ft.	Lb. In.	
Knock Sensor to Engine Block	21	16		
Oil Control Valve - Cam Phaser M8 Bolt	160	118		
Upper Oil Pan to Engine Block M8 Bolt	23	17		
Oil Cooler to Oil Filter Housing Screws	12		106	
Upper Oil Pan to Rear Seal Retainer M6 Bolt	10		89	
Oil Pan Drain Plug M14	27	20		
Oil Pressure Sensor to Oil Filter Housing	20		177	
Oil Temperature Sensor to Oil Filter Housing	20		177	
Piston Oil Cooler Jet to Engine Block M5	6		53	
Oil Filter Housing / Oil Cooler to Engine Block M6	12		106	
Oil filter Housing Cap	25	18		
Oil Pump to Engine Block M6 Bolt	12		106	
Oil Level Indicator to Engine Block M10 Bolt	35	26		
Oil Level Indicator to Cylinder Head M6 Bolt	17		151	
Oil Pump Sprocket M8 T45	26	18		
Oil Pump Pickup Tube Bracket to Windage Tray M6 Bolt	12		106	
Oil Pump Pickup Tube to Oil Pump M6 Bolt	12		106	
Oxygen Sensor to Exhaust Take Down Pipe M18	50	37		
PCV Valve M5 T25	4		35	
Spark Plug to Cylinder Head M12	18	13		
Starter Mounting M10 Bolt	47	35		
Tensioner to Engine Timing Cover Accessory Drive M10 Bolt	55	41		
Thermostat Housing to Coolant Crossover M6 Bolt	12		106	
Throttle Body M6 Bolt	9		80	
Engine Timing Cover M6 Bolt	12		106	
Engine Timing Cover M8 Bolt	25	18		
Engine Timing Cover M10 Bolt	55	41		
Upper Intake Manifold Support Bracket to Upper Intake Manifold M8 Bolt	17		177	
Upper Intake Manifold Support Bracket to Upper Intake Manifold M6 Bolt	9		80	
Variable Valve Timing Solenoid to Cylinder Head Cover M5 T25	4		35	
Wire Harness Retainer Bracket to LH Cylinder Head M6 T30	10		89	

**Caution:**

The 3.6L Pentastar Engine is NOT A FREE SPIN ENGINE. Care must be exercised during disassembly not to rotate the crankshaft or camshafts once the valvetrain chain assemblies have been altered in any manner.

**Caution:**

Do not lay cylinder heads on gasket sealing surfaces. The design of the Multi-Layer Steel (MLS) cylinder head gasket will not seal properly if there are any imperfections on the cylinder head or engine block. Use only approved plastic type gasket removing tools when cleaning these surfaces.

**Warning:**

Multi-Layer Steel (MLS) head gaskets have very sharp edges that could cause personal injury if not handled carefully.

**Note:**

Multi-Layer Steel gaskets require a scratch free sealing surface.

1. Remove all gasket materials from cylinder head and block using care not to gouge or scratch the aluminum sealing surfaces.
2. Non compressible debris such as oil, coolant, or RTV sealants not removed from bolt holes can cause the aluminum cylinder block to fracture when tightening fasteners.
3. Clean all cylinder head bolt holes in the engine block. Do not use any sealants or adhesives on fasteners, Multi Layer Gaskets, or any sealing surfaces unless specified in this procedure. Surfaces must be debris free and scratch free for proper sealing.

**NOT A FREE SPIN ENGINE**

Valve to Piston interference will occur if not properly disassembled / assembled



Notes:

New engines are ordered through Chrysler MOPAR under special order part number. Engines are preserved under long term packaging. Once received at the test laboratory, they should be disassembled and put into storage for future build. Cylinder heads should be completely disassembled and the valvetrain gear stored for future use.

Bare cylinder heads (Cores) should be sent to IMTS for re-work. Labs must use the IMTS Special Packaging to protect the cores from damage. Packaging contains special cushioning sleeves for both Right and Left cylinder heads.

1. Camshaft caps are identified on the sides, "1E-> , 2E->" etc. for exhaust camshafts and "1I-> , 2I->" etc. for intake camshaft caps. Caps must be kept in order.
2. Remove all valvetrain hardware from cylinder heads; camshafts, roller rockers, lash adjusters, valve springs, valve seals, and spark plugs.
3. Keep all camshaft bearing caps in order. Replace after valvetrain hardware removal. Do not use air or battery powered tools to tighten camshaft caps. Use a speed handle to lightly snug fasteners and torque M6 T30 fasteners to 9.5 Nm.
- 4 After removing all valvetrain gear and torquing all camshaft caps in their proper position, install the cylinder head in VCI bag and insert the assembly in the IMTS Packaging with proper inserts, Securely tape package and ship to: IMTS 8460 Ronda Dr. Canton, MI. 48187

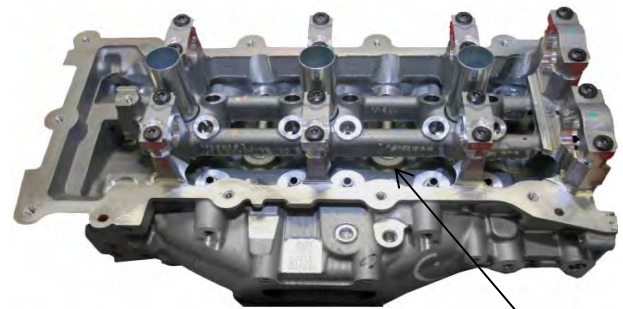

Do not remove oil gallery plugs or freeze plugs

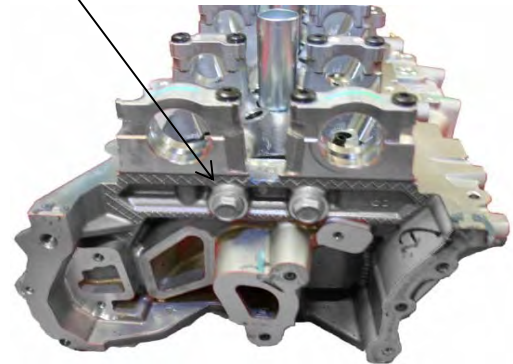

Top insert rotates 180° depending which head, left or right is in box.

Revision DRAFT	<h1>New Engine Disassembly</h1>	Section	3
Jan-15		Sheet	1

New engines are received from Chrysler as full assemblies. Upon delivery to the build area, they should be disassembled and prepared for test. Cylinder heads should be disassembled and the bare heads need to be packaged for shipment to IMTS for special processing. Packaging from the new cylinder heads to be used for the test should be used for return of new core materials to IMTS.

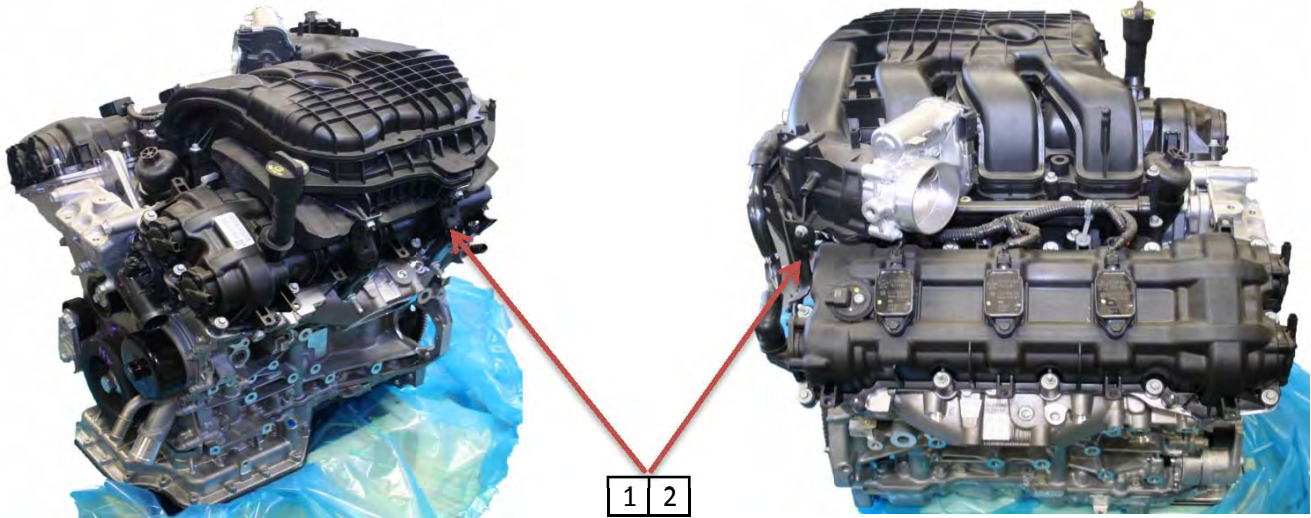

Remove the flywheel and disengage the ignition and fuel injector harness clips on the upper intake manifold brackets (1). Remove both upper intake manifold brackets (2).

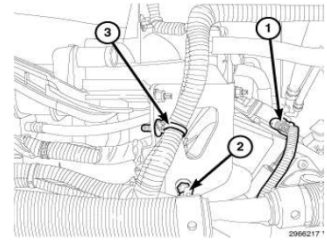
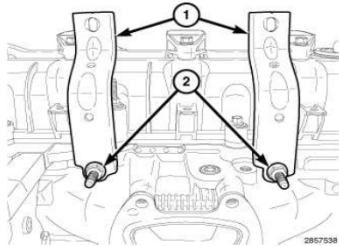

Remove PCV vacuum tube from rocker cover to upper intake manifold. Keep for later use on crankcase vent.

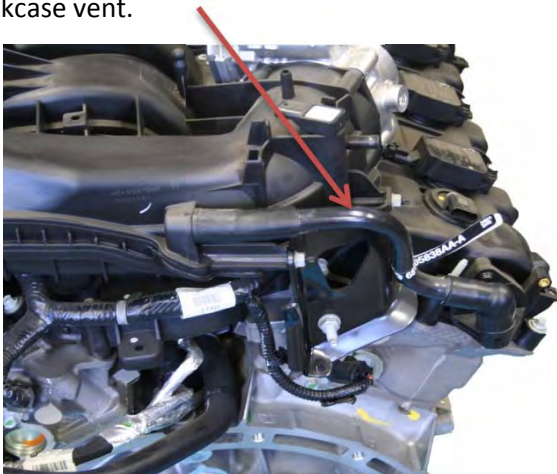

Remove upper intake manifold (2) fasteners (1)

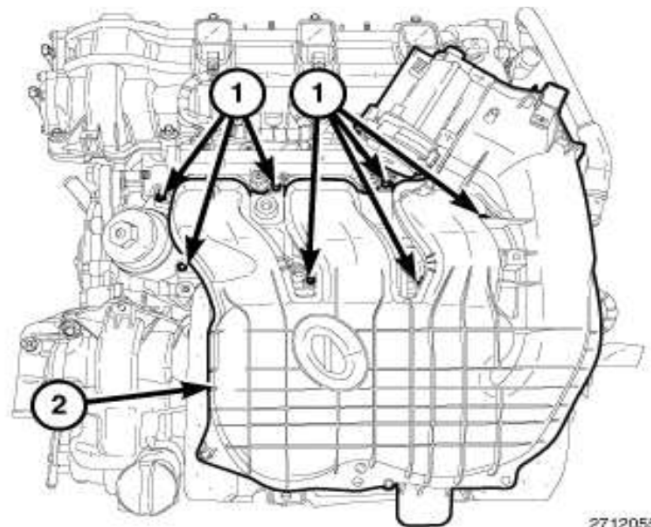

Disconnect all injection harness and ignition harness retainer clips. Disconnect coil pack electrical connectors. Disconnect fuel injector electrical connectors from fuel injectors. Remove harness.

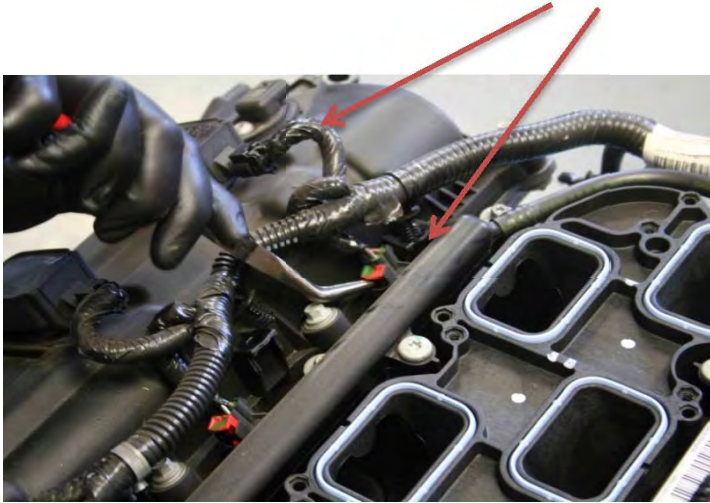

Remove the eight lower intake manifold attaching bolts (1).

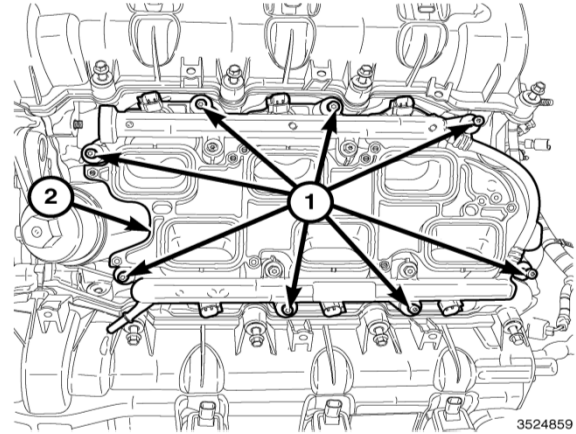

Remove the lower intake manifold (2) with the fuel injectors and fuel rail.



The lower intake manifold is an injection molded nylon composite design. The lower intake seals to the cylinder heads using six individual silicone gaskets. The seven upper intake manifold fasteners thread directly into the composite lower intake manifold and are self-tapping design. The fuel rail is also a composite design. The four fuel rail fasteners thread directly into the lower intake manifold and also are self-tapping design. The fuel rail and fuel injectors must be installed into the lower intake manifold as an assembly. Do not attempt to install the fuel rail when the injectors are in the manifold.

Need part number for lower intake seals.





Revision DRAFT	<h1>New Engine Disassembly</h1>	Section	3
Jan-15		Sheet	3

Install the Driver Side Engine Lifting Bracket 10242-1 (1) on the LH cylinder head with bolts (2) provided with the Engine Lifting Bracket. Tighten the bolts to 21 N·m (15 ft. lbs.).

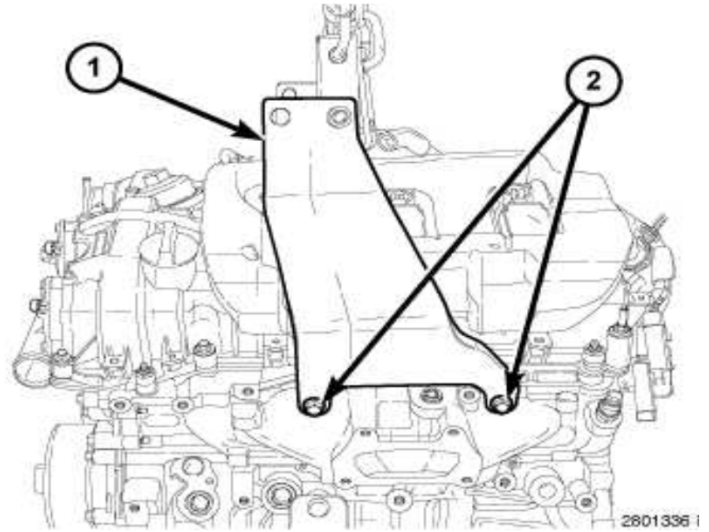

Install the Passenger Side Engine Lifting Bracket 10242-2 (1) on the RH cylinder head with bolts (2) from the Engine Lifting Bracket. Tighten the bolts to 21 N·m (15 ft. lbs.).

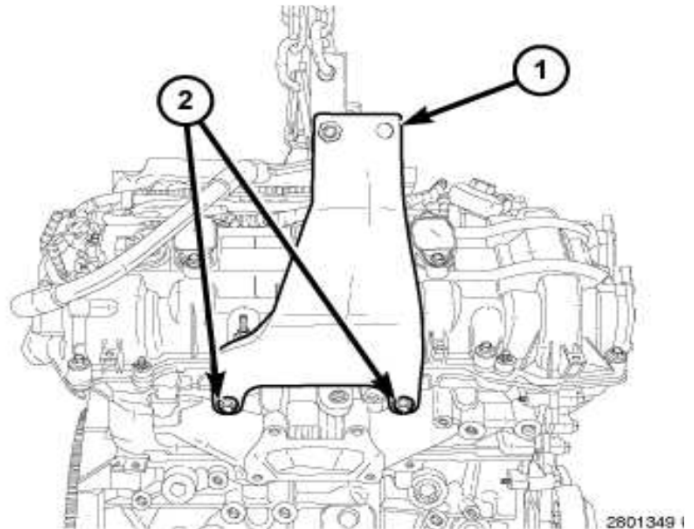

Labs may also chose to fabricate in-house lifting brackets. Care should be taken to ensure the brackets keep all chains and hooks from contacting the camshaft covers. It has been found that plates attached to the exhaust manifold fastener area work well when moving fully assembled engines.

Once positioned on the roll over stand, drain the factory fill engine oil before rotating the engine and remove the front balancer and dip stick tube.

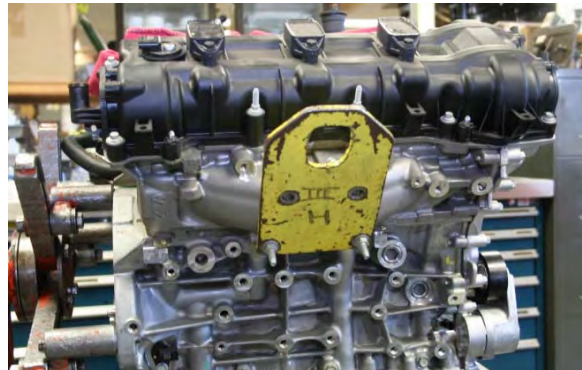

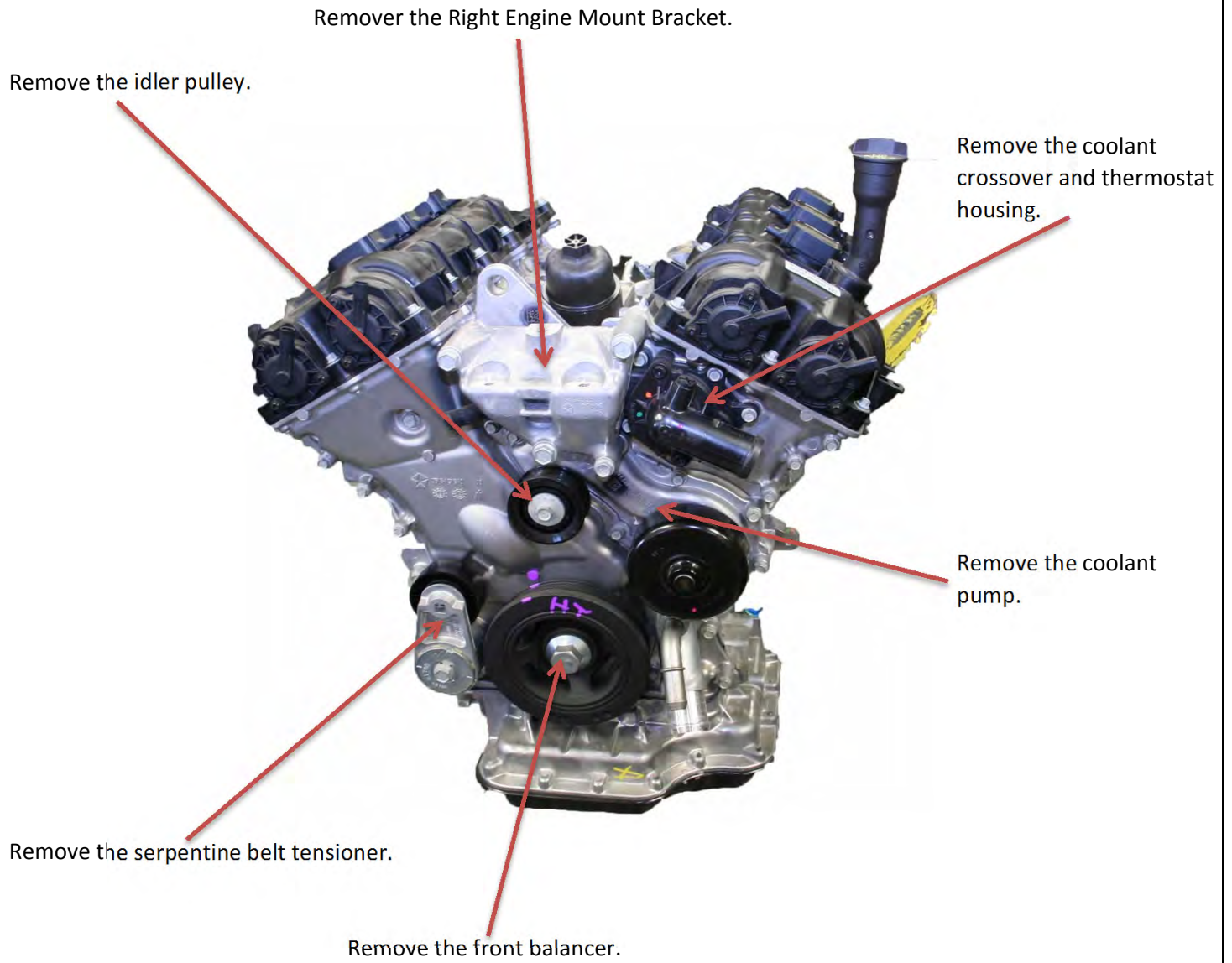

Drain all fluids in the engine, rotating the engine to remove as much oil from the oil pan as possible.

Disconnect all harness retainer clips and connections from the oil filter housing sensors and coolant hose assembly.

Remove the fasteners (2) holding the oil filter housing (1) and oil cooler to the engine valley.

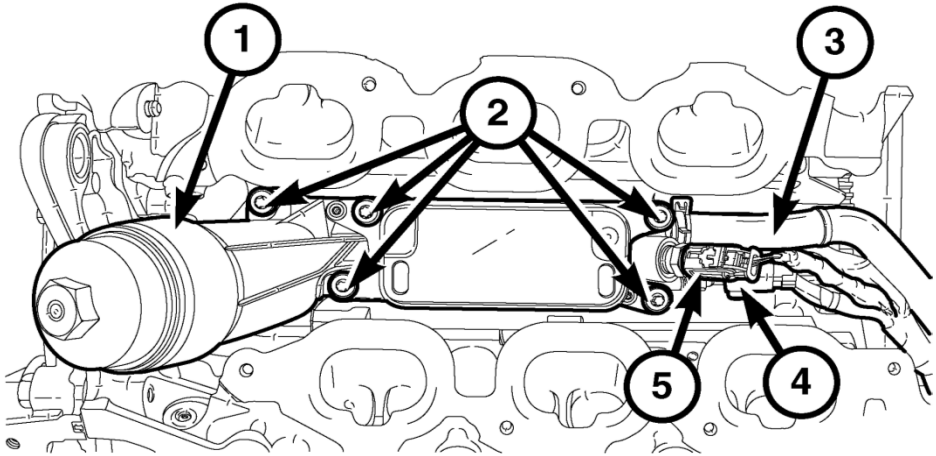

Do not remove the screws (1) and (3) holding the oil cooler to the oil filter housing.

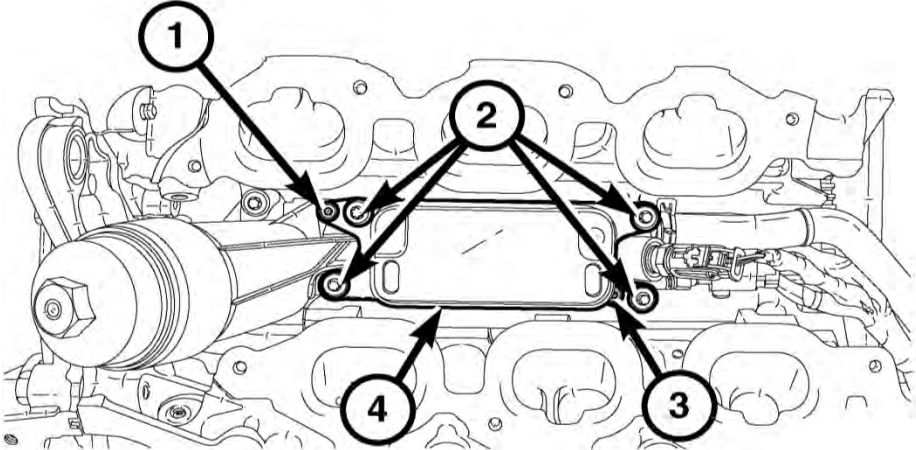

Need part numbers for all oil filter housing seals

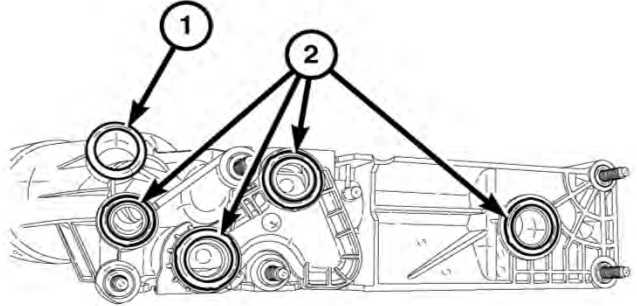

Revision DRAFT	New Engine Disassembly	Section	3
Jan-15		Sheet	6

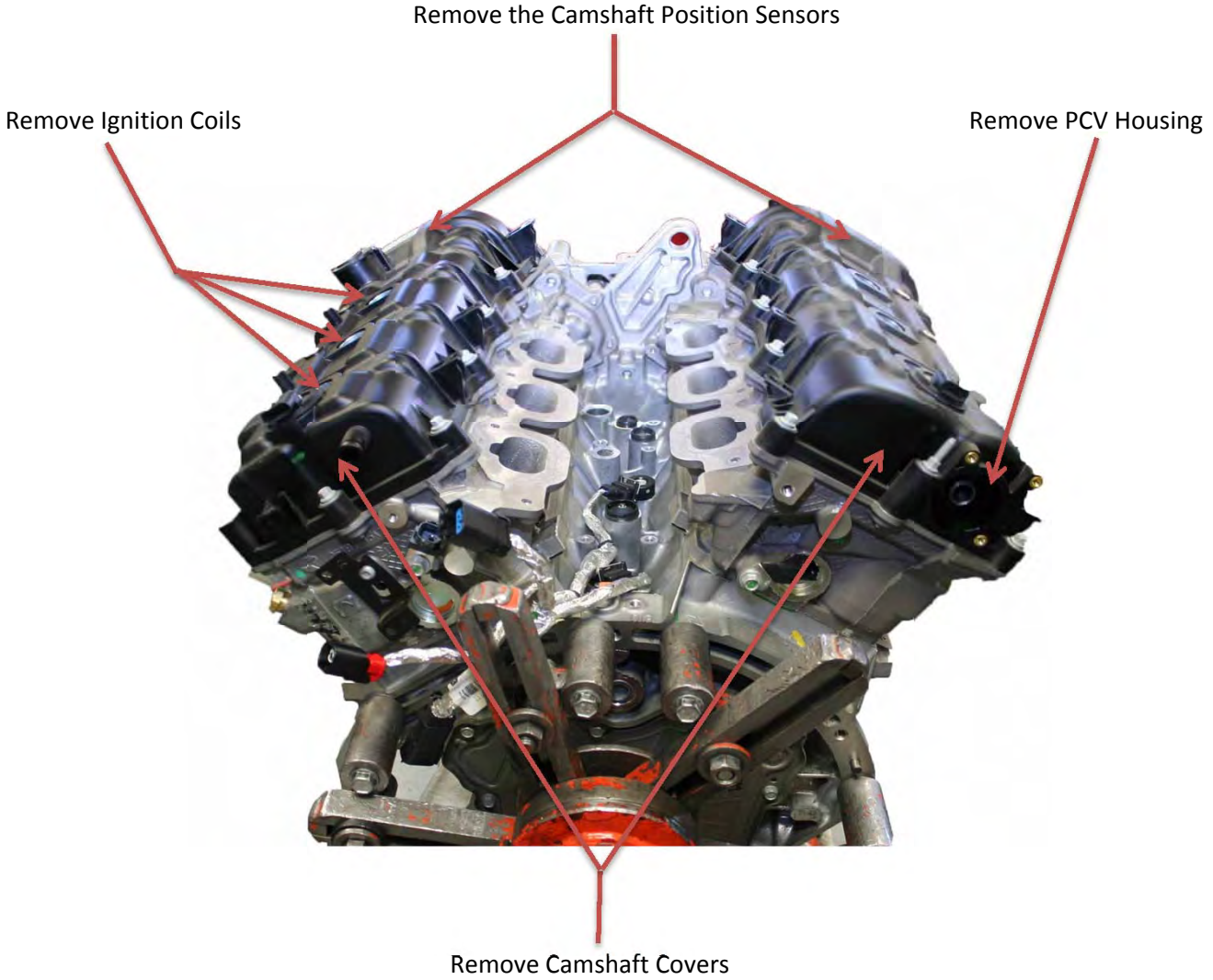

Care should be used to prevent damage to the camshaft cover seals at the joint between the front cover and cylinder head by using a sharp putty knife to slice the RTV sealer in these areas as the cover is lifted from the cylinder head.

Remove the lower oil pan fasteners. Use a sharp, rigid putty knife to cut the RTV sealer between the lower and upper oil pans. Remove the lower oil pan.



Remove the upper oil pan fasteners. Use the pry points to break the RTV bond. Apply pressure on the front of the upper oil pan while tapping with a plastic mallet to remove the assembly.



Note: main cap side bolts have also been removed while removing upper oil pan fasteners.

Remove the engine timing chain front cover fasteners.



Using an appropriate pry bar, break the RTV seal at the pry points between the front cover and block. Remove the engine timing chain front cover.



**Caution: Camshaft timing alignment is not performed during engine disassembly.**  
**Once the timing chain assemblies are removed, do not rotate the crankshaft until the camshafts are removed.**



Remove all timing chain tensioners, guides, and chains.



Remove the camshafts, roller rockers, lash adjusters, cylinder head fasteners, and cylinder heads. Re-install the camshaft bushing caps. Remove the valve springs and valves and package the cylinder heads for shipping to IMTS for processing.

Remove the windage tray and main cap side bolts.



Mark the positions on the connecting rods and remove the piston and rod assemblies.



Remove the crankshaft and prepare the engine block for cleaning. Follow procedure for pre stressing and honing the block for test.





Revision DRAFT	Cylinder Block Main Oil Gallery Thermocouple Installation Tools	Section	4
May-15		Sheet	1

The rear main oil gallery is modified to adapt an 1/8 thermocouple just below the mixing point where the oil cooler flow and the oil cooler by-pass flow intermix as it enters the main oil gallery. Special modifications are required to perform these operations and are outlined in this section of the cleaning and pre-hone preparations section of the manual.

**Special tooling fixtures and tools to perform this operation are required and provided through IMTS**

**IMTS Chrysler 3.6L Thermocouple Tapping Fixture Assembly 151132-F001**

1. Thermocouple Tapping Fixture 151132-F001 (Main Plate Less Total Assembly Components)

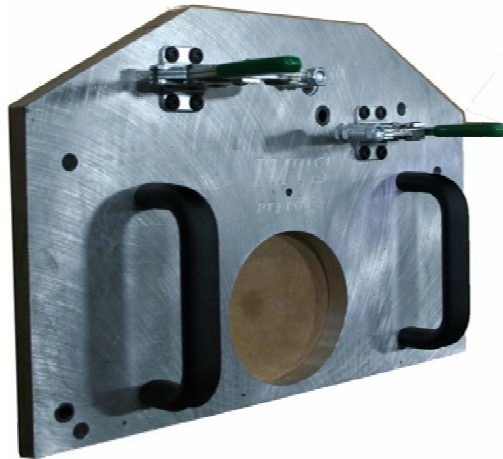

2. Thermocouple Tapping Jig 151132-J001



3. Thermocouple Setting Fixture 151132-F002



4. Thermocouple Tapping Jig Tools and Fasteners

- a. Clearance Drill 151132-T001
- b. Aircraft Drill Special 151132-T002
- c. NPTF Tap Special 151132-T003
- d. Oil Gallery Clean Plug 151132-P003
- e. Fixture Fasteners

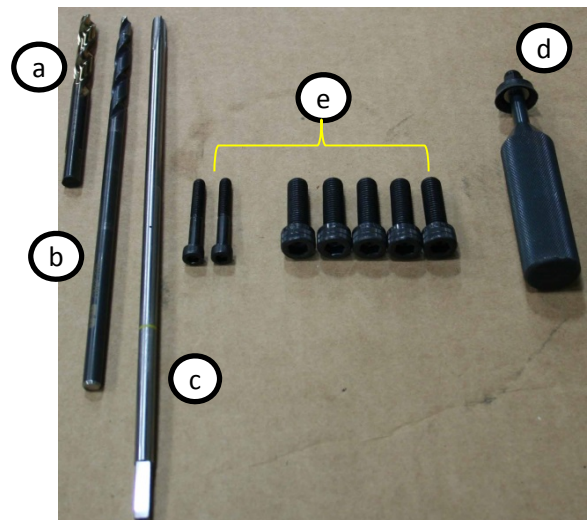

Revision DRAFT	Cylinder Block Main Oil Gallery Thermocouple Modification	Section	4
May-15		Sheet	2

1. Remove the main oil gallery access plug from the right side of the engine. Remove the Crankshaft Sensor from the right side of the engine.

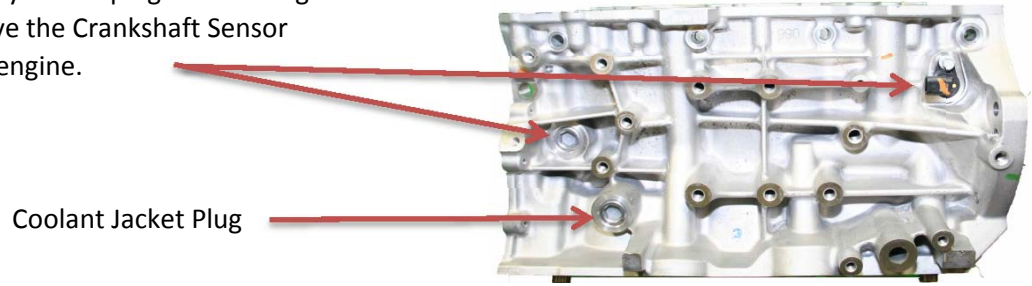

2. Remove the main oil gallery access plug from the left side of the engine.

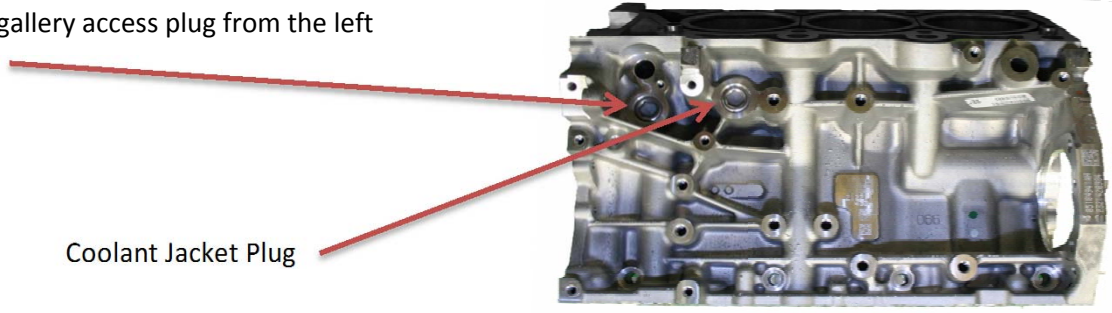

3. Remove the cup plug from the front main oil gallery.

**Do not remove the timing chain idler gear pressed fit shaft**

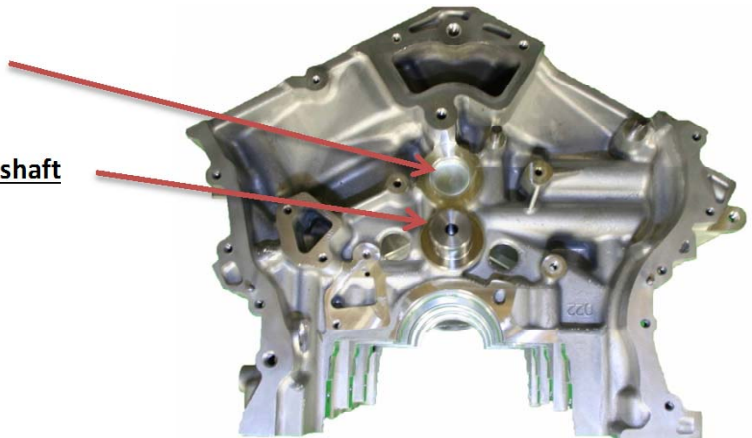

4. Remove the rear main oil gallery plug.

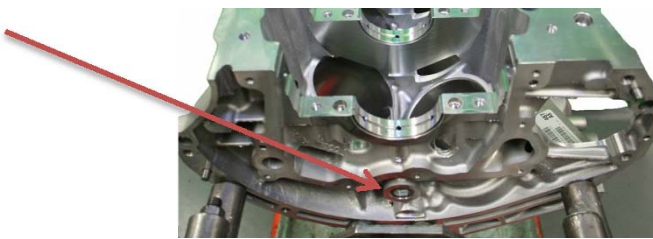

5. Remove all three piston cooling jet assemblies from the main oil gallery.

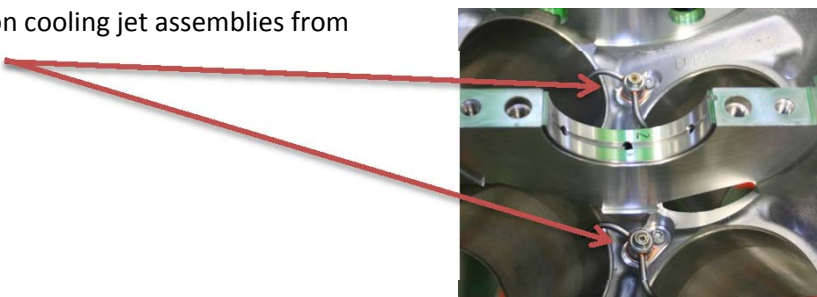

6. Attach the main tooling fixture plate to the rear of the engine aligning the plate over the transmission dowel pins with five allen hex fasteners.



7. Install the oil gallery Clean Plug Assembly 151132-P003 using EF-411 or an assembly type grease on the leather seal to aid in preventing machining debris from entering the lower main oil gallery. Gently rock the plug assembly back and forth installing the tool until it bottoms in the oil gallery.



8. Using a 1/2 inch Drill Motor with the Clearance Drill 151132-T001, drill a clearance hole through the rear China Wall of the engine block using the hardened bushing to guide the drill bit through the China Wall.



Revision DRAFT	Cylinder Block Main Oil Gallery Thermocouple Modification	Section	4
May-15		Sheet	4

9. Install the main oil gallery thermocouple drilling and tapping fixture 151132-J001 to the rear of the engine. Note the round and triangular alignment pin combination on the fixture for ease of installation alignment. Secure the 151132-J001 fixture using the toggle clamps and allen hex head fasteners.

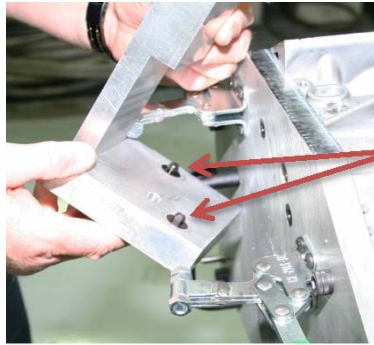

Fasteners  
(Snug Only)

Alignment pins

Toggle Clamps

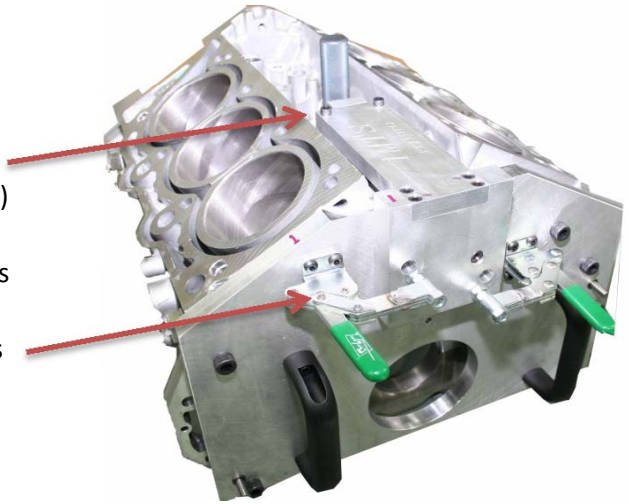

10. Using a 1/2" drill motor with the Special Tip Aircraft Drill 151132-T002, drill through the main oil gallery until the tip of the drill breaks through the inside.

**Note special cut tip on tool 151132-T002**

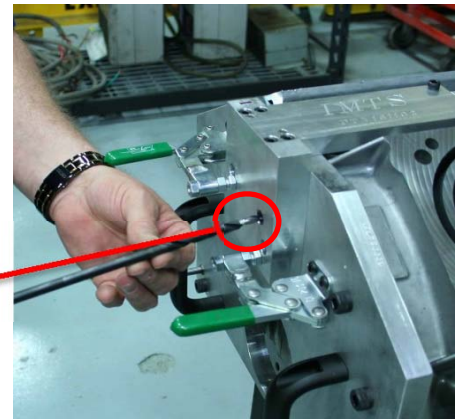

11. Using an appropriately sized Tee Handle with the special length tapping tool 151132-T003 1/16" NPTF Tap, thread the drilled hole in the main oil gallery until the Yellow Ring on 151132-T003 meets the hardened bushing guide on the tapping fixture 151132-J001.

**Note, the use of a tapping lubricant or grease to hold machining debris is recommended.**

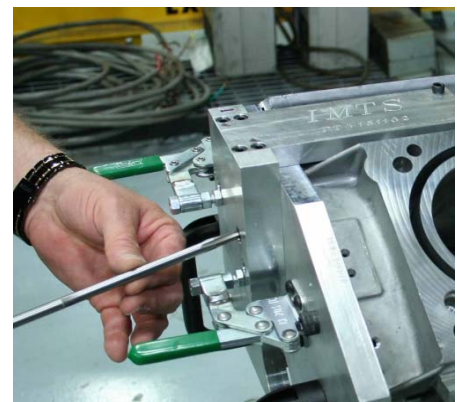

12. After threading the main oil gallery, carefully remove all fixture tooling, leaving the Clean Plug Assembly in the main gallery.

**Using preferred laboratory cleaning practice, clean the threads and any machining debris from the main oil gallery. Carefully remove the Clean Plug Assembly and inspect the threaded hole for any burrs or sharp edges on the inside of the main oil gallery.**



Revision DRAFT	Cylinder Block Cleaning Pre Hone Prep	Section	4
May-15		Sheet	5

1 After disassembly and modification of the main oil gallery, technicians should carefully clean all RTV from mating surfaces using care to avoid scratching or gouging any mating surfaces. Spray degreasing solvent through all oil gallery passages from the underside through the piston cooling jet access holes to clean any debris from galleries.

**Caution:**

Technicians should exercise extreme caution while cleaning mating surfaces of the engine block. Use only plastic type non marring scrapers for removal of RTV and other debris from mating surfaces. Visual imperfections on the cylinder deck and other gasket sealing areas may remain even after removing RTV.

2 If desired, chase all threaded bolt holes for the cylinder head bolt holes and the main cap bolt holes using cleaning thread chase taps. Avoid using thread cutting type taps to clean threads. Thread cleaning taps are available through sources such as ARP, Snap-on, or Mac Tools for SAE and Metric thread sizes.

**Caution:**

Non compressible debris such as oil, coolant, or RTV sealants not removed from bolt holes can cause the aluminum cylinder block to fracture when tightening fasteners.

3 Clean the engine block prior to honing using either of the following methods;

- a. Clean in the spray booth using degreasing solvent followed by a 50/50 solution of EF-411 and Degreasing Solvent followed by air dry using clean dry compressed shop air.
- b. Clean using the Ultra Sonic Cleaner following the manufacturers recommendations followed by a water rinse and spray with a 50/50 solution of EF-411 and Degreasing Solvent followed by air dry using clean compressed air.

4 Clean and inspect the cylinder head fasteners from the New Engine Disassembly.

5 Lightly oil the cylinder head fasteners with EF-411 and allow to drain all excess oil from the threads using clean Teri towels before installation of cylinder torque plates.

6 Clean and lightly oil the main cap fasteners and side bolts using EF-411 allowing all excess oil to drain from the threads using clean Teri towels.

7 Cylinder head gaskets are Multi-Layer Steel gaskets. The cylinder head gaskets removed during the New Engine disassembly can be re-used with the BHJ Torque Plates and spacers used to position the fasteners at the correct bolt drop in the cylinder block.

8 A good practice for build technicians is to ensure there is no oil or debris in the blind threaded bolt holes before assembling the main caps or cylinder block torque plates using compressed air or blotting with absorbant materials.

- 1 Install the main caps using both the inner and outer main cap fasteners.  
 Note: The outer main cap fasteners are used without the windage tray in place for the honing operation.
- 2 Use a socket with a speed handle in a criss cross pattern working from the center out to seat the main caps. Start with the inner fasteners and then the outer fasteners. See View A. (Positions 1 through 16)
- 3 After seating the main caps, loosen all 16 main cap fasteners 1/4 turn.
- 4 Torque the inner main cap fasteners to 20 N·m (15 ft. lbs.) plus 90° following the inside out pattern shown in View A. Fastener positions ① through ⑧.
- 5 Torque the outer main cap fasteners (without the windage tray) to 21 N·m (16 ft. lbs.) plus 90° following View A. Fastener positions ⑨ through ⑯.
- 6 Install the eight main bearing cap tie bolts (side bolts) and tighten the fasteners to 28 N·m (21 ft. lbs.) using the sequence shown in View A. ① through ⑧

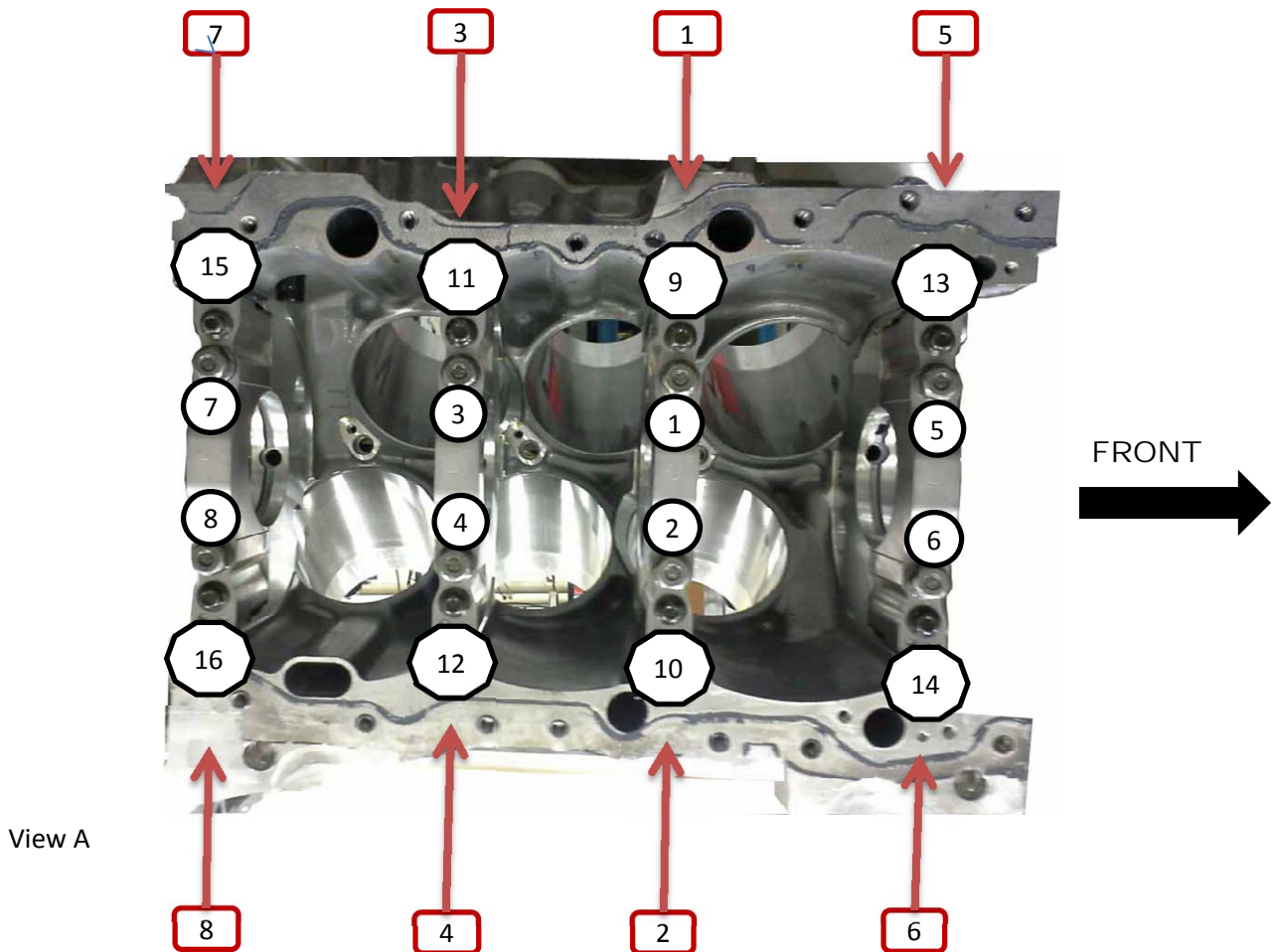

**Required Parts and Equipment**

1. Sunnen SV-10 Honing Machine
2. Sunnen Honing Oil SHO965055/SHO965005
3. Course Diamond Stones: Sunnen DHH6GMH85
4. Plateau Brush: Sunnen DHHB6534 (DHHB7534 is an adequate substitute)

**Machine Setup**



Using the automated setup screens input the following parameters;

Screen 1	Bore Diameter	95.90mm
	Bore Length	131.76mm
	Stone Length	76.20mm
	Over stroke Top	9.65mm
	Over stroke Bottom	9.65mm
Screen 2	Roughing Spindle Speed RPM	200
	Roughing Stroke Speed	80
	Finishing Spindle Speed RPM	200
	Finishing Stroke Speed	80

These user input values should yield an average X-hatch angle of 36° and a stroke length of 65.9mm.

Place the block in the SV-10 honing machine with the front of the block facing left.  
Set the stroke length before installing the torque plates to 74.9mm.

Revision DRAFT	Cylinder Block Honing Prep Torque Plate Installation	Section	4
May-15		Sheet	8

- 1 Install the engine block in the honer and tighten the block in place using the honing bar through the main caps.
- 2 With the front of the block facing to the left, and the engine angled so the left side deck is up, install the left side cylinder head gasket and BHJ Torque Plate identification MP-3.6PSV6-R-AL-T-DID.
- 3 Install the fasteners with the BHJ Spacers and tighten by hand following the proper torquing procedure.
- 4 Rotate the engine so the right side deck is angled up and install the cylinder head gasket, torque plate, and fasteners with spacers as outlined in line item 2 and 3.
- 5 Torque the cylinder head fasteners following the inside out pattern identified in View D to the following procedure.
  - a. All fasteners to 30 N·m
  - b. All fasteners to 45 N·m
  - c. All fasteners plus 70° (First Pass)
  - d. All fasteners plus 70° (Second Pass)

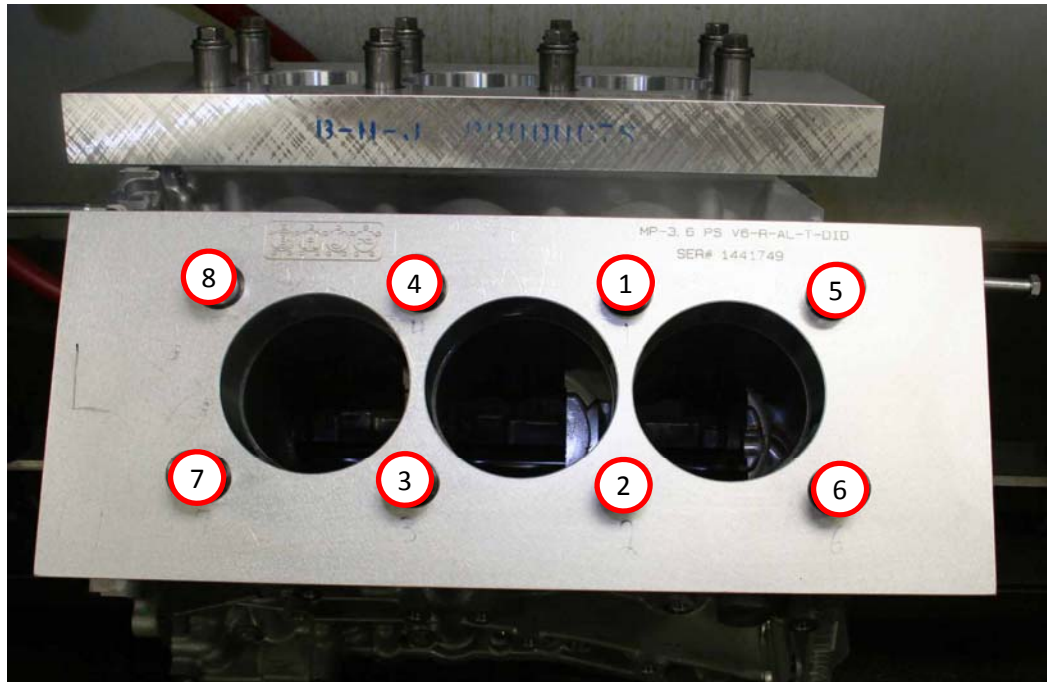

View D



With the honing fluid flow rate set at 7 l/m and the Auto Dwell setting On.  
 Use the course hone speed setting with the DHH6GMH85 Diamond Stones at a setting of 30 to 40 units load to hone each cylinder to a target bore size of 96.035 to 96.045mm diameter.

**Note:**  
 Care should be exercised to prevent the machine from auto dwelling as it gets close to the target bore diameter.

Once the target diameter has been achieved, switch to the DHHB6534 Brush Hone and using the course hone speed run the honer maintaining 10 to 15 units load for 6 to 10 strokes to achieve the desired surface finish parameters.

**Measurements**

**Bore Size:**  
 Record bore measurements in the transverse and longitudinal directions at 0.5, 2.0, and 3.5 inch positions below the cylinder block deck surface. Maximum out-of-round specification is 0.005mm and maxim taper is 0.015mm.

Using the Mitutoyo Surf Analyzer model number SJ-410 with holder model number 12AAB409 and a 5 micron tip, record the surface finish parameters 1.0 inch below the cylinder block deck surface.

Target Specifications	
Rk	0.75 to 1.5 µm
Rpk	0.13 to 0.80 µm
Rvk	1.00 to 2.5 µm
Rz	3.50 to 6.00 µm
Mr2	70% Minimum

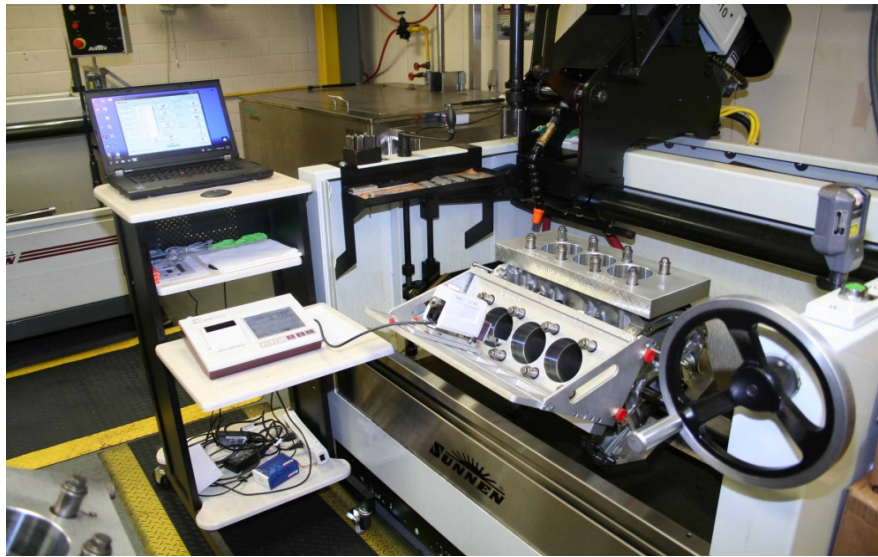

Follow standard laboratory cleaning procedures to clean the block after honing using either the spray booth with degreasing solvent followed by a 50/50 solution of degreasing solvent and EF-411 and air drying, or cleaning the block using the Ultra Sonic Cleaner following the manufacturer recommendations followed by a water rinse and spray with a 50/50 solution of degreasing solvent and EF-411 followed by air drying.

Revision DRAFT	Short Block Assembly General Information	Section	5
Jan-15		Sheet	1

The cylinder block is a 60 degree high-pressure die cast aluminum design with cast steel cylinder liners. The leading side of the block is on the right side and houses cylinders 1, 3 and 5. The cylinder block is an open deck design with cut slots between each cylinder. Two knock sensors are located in the block valley. The cylinder block has three sets of piston cooling jets which are attached to the main oil gallery. The four powdered metal main bearing caps are a cross-bolted design and have directional arrows molded into the caps. The number 2 main bearing is the location for the two piece upper half thrust bearings. The thrust bearings are installed with the oil grooves facing outward. The main bearing caps are a 6-bolt design and cross-bolted for improved lower end strength. There are three oil drain back drillings located on

Blocks and crankshafts are precision measured during manufacture and marked with specific bore and journal size identifications. Bearing shells are manufactured to provide select fit clearances based on these

**Note:**

Engines should be kept with their respective parts as select fit clearances will differ between each engine. Clearances may be confirmed through actual measurements with reference to the following bearing selection charts and identification markings on the block and crankshaft. See Section 5 Sheet 2

**Note:**

Crankshaft thrust washers are not selectable and are only available in single thickness.

**Caution:**

Main bearing fasteners are snug torque plus angle tightening. Main bearing fasteners are Not Yield Fasteners. Main bearing fasteners have been torqued twice during manufacture. Labs should strive to minimize the number of torque applications during test build. If threads in the block are pulled during assembly, the labs are allowed to use thread inserts, however, labs must understand the main caps are positioned through the shoulder of the fastener and threaded inserts could cause misalignment.

**Note:**

Main Bearing cap bolts are replaced as necessary.  
Cylinder head bolts are reused for torque plate application during honing.  
Cylinder head bolts are replaced with new fasteners for test build.  
Connecting rod cap bolts are replaced for test build.

All reused fasteners should be checked for necking before use.

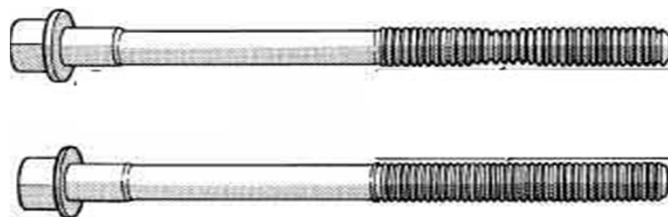

Revision DRAFT	Short Block Assembly Block / Crank / Conn Rod / Bearing Selections	Section	5
Jan-15		Sheet	2

The connecting rod bearings are “select fit” to achieve proper oil clearance. Connecting rod bearing journal diameter grade markings are stamped into the front crankshaft counterweight. Markings read from left to right journals 1 through 6.

The connecting rod bearing shells (1) are marked with the bearing size (2) on the bearing lining surface.

The bearings are available in three different sizes in order to achieve the desired oil clearance.

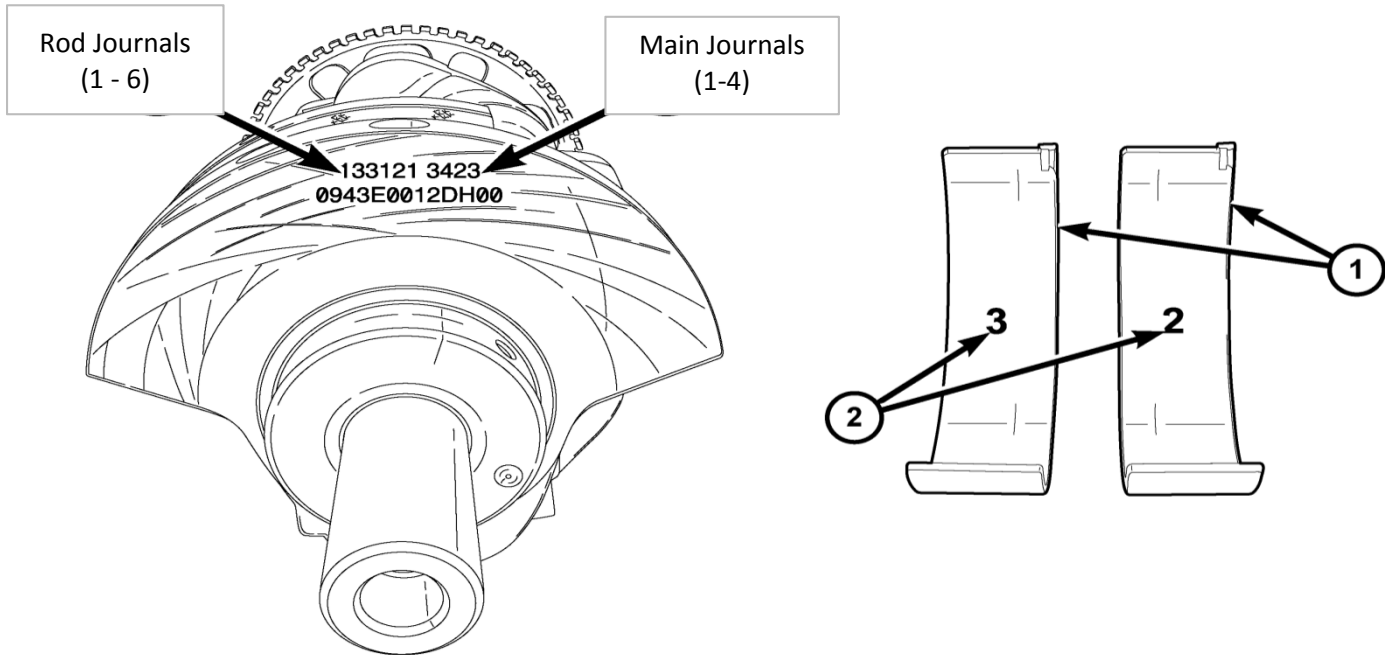

Rod bearing shells are available in three sizes. The chart below identifies the three bearing sizes.

Crankshaft Marking	Journal Size mm (Inch)
1	58.9910 - 58.9969mm (2.3225 - 2.3227 in.)
2	58.9970 - 59.0029mm (2.3227 - 2.3229 in.)
3	59.0030 - 59.0090mm (2.3229 - 2.3232 in.)

Bearing Marking	Bearing Shell Size mm (Inch)
1	1.583 - 1.580mm (0.0623 - 0.0622 in.)
2	1.580 - 1.577mm (0.0622 - 0.0621 in.)
3	1.577 - 1.574mm (0.0621 - 0.0620 in.)

**Install rod bearings in pairs, Do Not Mix connecting rod bearing shells**

Revision DRAFT	Short Block Assembly Block / Crank / Conn Rod / Bearing Selections	Section	5
Jan-15		Sheet	3

The upper and lower main bearings are “select fit” to achieve proper oil clearances. Crankshaft main bearing journal diameter grade markings are stamped into the front crankshaft counterweight. These marks are read from left to right, corresponding with journal number 1, 2, 3, 4. See Section 5 Sheet 2

Crankshaft Marking	Journal Size mm (Inch)
1	71.9870 - 71.9905 (2.8341 - 2.8343 in.)
2	71.9906 - 71.9941 (2.8343 - 2.8344 in.)
3	71.9942 - 71.9977 (2.8344 - 2.8345 in.)
4	71.9978 - 72.0013 (2.8346 - 2.8347 in.)
5	72.0014 - 72.0050 (2.8347 - 2.8348 in.)

Engine block main bore size identification from the left, front to rear ( 1 - 4).

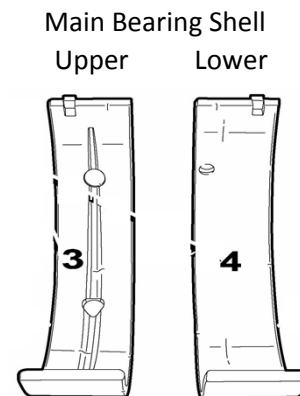
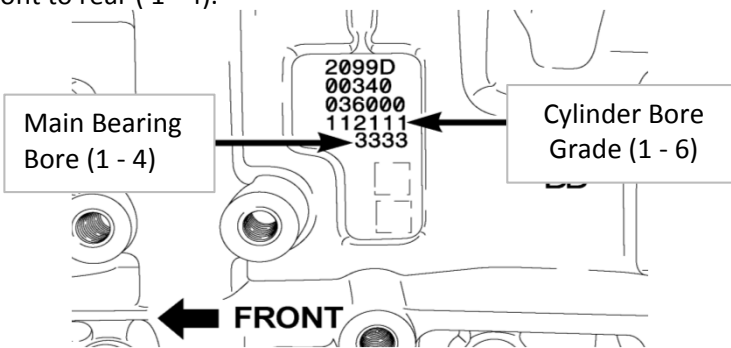

Engine Block Marking	Main Bore Size mm (Inch)
1	77.0055 - 77.0090 (3.0317 - 3.0318 in.)
2	77.0019 - 77.0054 (3.0316 - 3.0317 in.)
3	76.9983 - 77.0018 (3.0314 - 3.0316 in.)
4	76.9947 - 76.9982 (3.0313 - 3.0314 in.)
5	76.9910 - 76.9946 (3.0311 - 3.0313 in.)

Engine Block Marking	Crankshaft Marking				
	1	2	3	4	5
1	1/1	1/2	2/2	2/3	3/3
2	1/2	2/2	2/3	3/3	3/4
3	2/2	2/3	3/3	3/4	4/4
4	2/3	3/3	3/4	4/4	4/5
5	3/3	3/4	4/4	4/5	5/5

Upper / Lower main bearing combinations to achieve 0.024 - 0.050mm (0.0009 - 0.0020 in.) clearance.

Revision DRAFT	Short Block Assembly Piston Ring Gap / Piston Cooling Jets	Section	5
Jan-15		Sheet	4

#### Piston Ring Gap Measurement:

Position the top and second piston rings ~ 1 inch down from the top of the bore. Using a Starrett Taper Gage Model 270, measure the gap and record the pre-test measurement on the appropriate engine build data form.



#### Cylinder Bore Cleaning:

Because the piston cooling jets protrude into the bottom of the cylinder bore, technicians should consider cleaning the cylinder bores and oiling them for piston installation before piston cooling jet installation.

Clean the cylinder bores with clean lint free terry towels using EF-411 to ensure cylinder bores are clean and debris free for continued assembly.



#### Piston Cooling Jets:

Lubricate the O-ring on the piston cooling jet with EF-411 engine assembly lube.

Install the piston cooling jet and torque the fastener to 6 N·m (53 in. lbs.).

Piston cooling jets are targeted during manufacture. Care should be exercised not to damage or bend the nozzle during handling.

Piston cooling jets have a check valve which closes below 2.5 bar (35 psi). Piston cooling jets should be replaced every test.

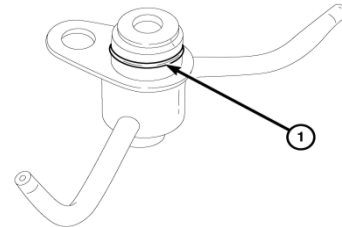

Revision DRAFT	Short Block Assembly Main Bearing / Crankshaft Installation	Section	5
Jan-15		Sheet	5

Refer to Section 5 Sheet 3 for main bearing selection.

**Main Bearing Selection:**

Check the crankshaft identification codes on the front counterbalance for the main journal diameter codes and record the data in the appropriate build document.

Check the engine block identification codes on the identification pad for the main bearing bore codes and record the data in the appropriate build document.

Using the table in Section 5 Sheet 2, select the appropriate bearings for the engine block / crankshaft combination and record the information in the appropriate build document.

In all positions, the upper bearing should be equal to or less than the lower main bearing selection.

Install the upper main bearings in positions 1 - 4.

Main Bearing Shell  
Upper      Lower

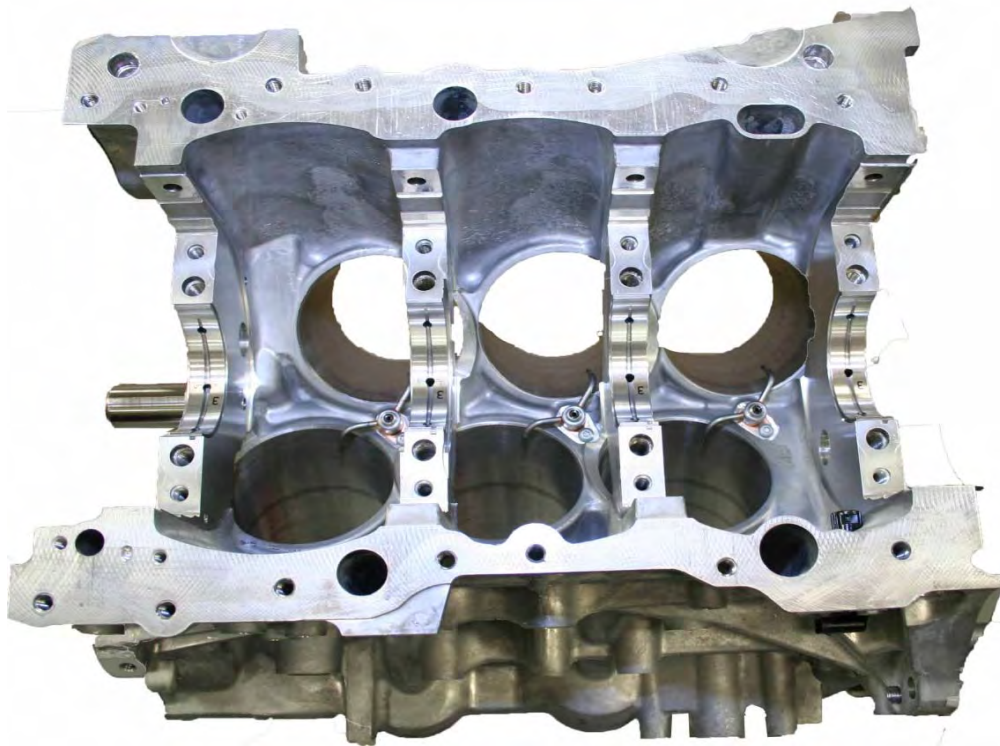
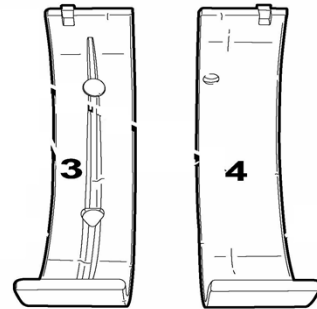

**Part Numbers:**

- 05184103AH    MAIN BEARING UPPER Grade 1
- 05184104AI    MAIN BEARING UPPER Grade 2
- 05184105AI    MAIN BEARING UPPER Grade 3
- 05184106AI    MAIN BEARING UPPER Grade 4
- 05184107AI    MAIN BEARING UPPER Grade 5

Revision DRAFT	Short Block Assembly Main Bearing / Crankshaft Installation	Section	5
Jan-15		Sheet	6

Lubricate the upper main bearings using EF-411 Assembly Oil.



Install the crankshaft and lubricate the journals with EF-411 Assembly Oil.

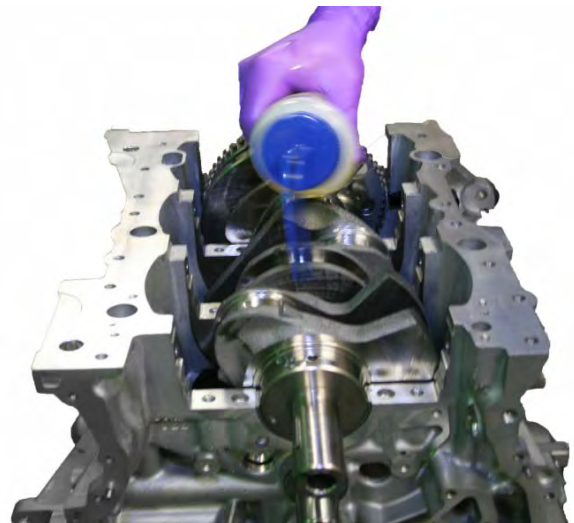

Install the thrust washers

Installing thrust washers (1) at the No. 2 main bearing location, using the following procedure:

- a. Move the crankshaft forward to the limit of travel. Lubricate and install the front thrust washer (1) by rolling the washer onto the machined shelf between the No. 2 upper main bulk head and crankshaft thrust surface.
- b. Move the crankshaft rearward to the limit of travel. Lubricate and install the rear thrust washer by rolling the washer onto the machined shelf between the No. 2 upper main bulk head and crankshaft thrust surface.



Revision DRAFT	Short Block Assembly Main Bearing / Crankshaft Installation	Section	5
Jan-15		Sheet	7

Install the lower main bearings in the main caps (1 - 4).

Part Numbers:

- 05184086AG MAIN BEARING LOWER Grade 1
- 05184087AH MAIN BEARING LOWER Grade 2
- 05184088AH MAIN BEARING LOWER Grade 3
- 05184089AH MAIN BEARING LOWER Grade 4
- 05184090AH MAIN BEARING LOWER Grade 5

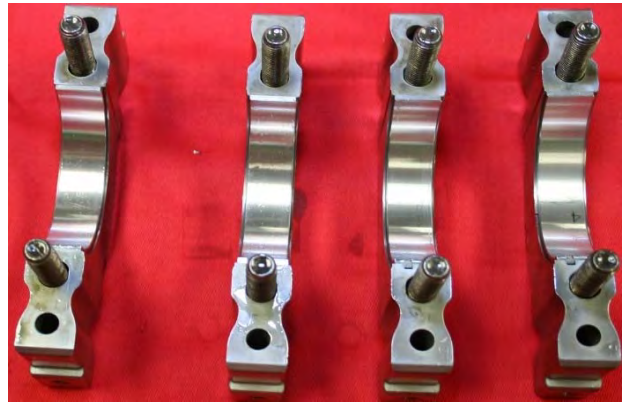

Install the lower main bearing caps with bearings. Lubricate the inner fasteners with EF-411 and snug the fasteners using a speed handle to draw the main caps down uniformly to seating the main caps. Back the fasteners off and check the forward and aft movement of the crankshaft.



Torque the inner main cap fasteners to 20 N·m (15 ft. lbs.) plus 90° following the inside out pattern shown in View A.



Install the eight main bearing tie bolts. Tighten the bolts in the sequence shown in View B to 28 N·m (21 ft. lbs.).

Note: Crankshaft may be tight until side bolts are installed and windage tray is torqued.

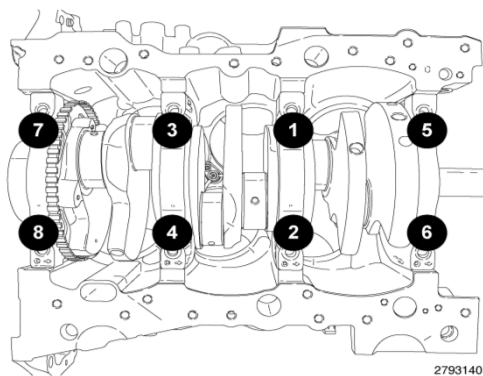

View A

2793140

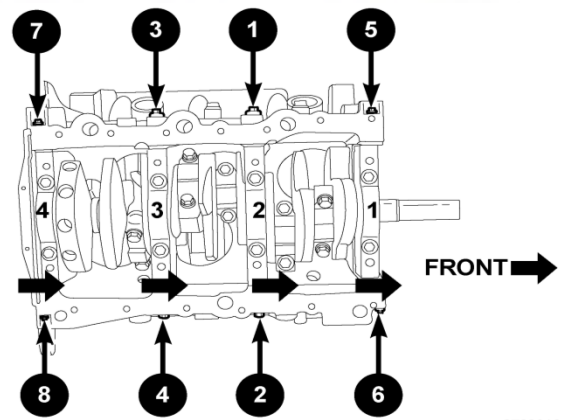

View B

2792316



Revision DRAFT	Short Block Assembly Piston Assembly	Section	5
Jan-15		Sheet	8

Remove the connecting rod from the production piston assembly



Note:  
GANORF  
Tab on bottom  
of connecting  
rod denotes  
FRONT

Install the production connecting rod on the OHT Test Piston using the new piston pin and spiral clips

Part Numbers:

OHT3H-070-1 PISTON, SPECIAL TEST  
OHT3H-071-1 PIN, WRIST, PISTON  
OHT3H-072-1 CLIP, PISTON, WRIST PIN

Revision DRAFT	Short Block Assembly Piston Ring Install	Section	5
Jan-15		Sheet	9

**Caution:**

To avoid damage to the piston rings, they must be installed in the following order:

- Oil ring expander (5)
- Oil ring lower side rail (4)
- Oil ring upper side rail (3)
- No. 2 (intermediate) piston ring (2)
- No. 1 (upper) piston ring (1)

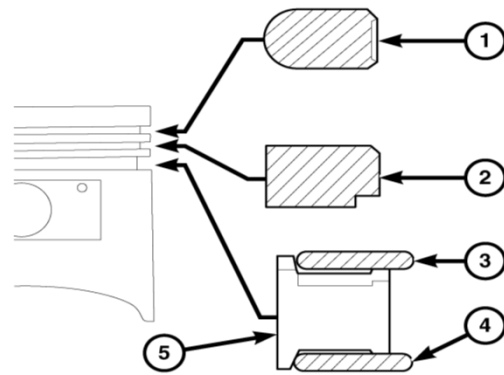

**Note:**

Typical piston shown. Do not use a piston ring expander to install the oil ring side rails.

Install the oil ring expander (1).

Install the oil ring lower side rail by placing one end between the piston ring groove and the oil ring expander. Hold this end firmly and press down the portion to be installed until the side rail is in position.

Install the oil ring upper side rail in the same manner as the lower side rail.

The No. 1 (upper) piston ring (1) and No. 2 (intermediate) piston ring (3) have a different cross section. Install the rings with manufacturers I.D. mark (dot) (2) facing up, towards the top of the piston.



Install the 2nd and top piston rings using the same method by placing one end of the ring into the piston ring groove and rolling the ring around the piston into the groove.

Use care to prevent over expanding the piston ring during this operation and also not to allow the gap edge to scratch the piston land area.

**Do Not Use Piston Ring Expanders as these are low tension rings and over expanding will change the tension.**

**Part Numbers:**

- 3H96040-TOP RING, SPECIAL TEST, UCR (.025" GAP, 96.040 BORE)
- 3H96040-SECONRING, SPECIAL TEST, LCR (.035" GAP, 96.040 BORE)
- 3H96040-EXP EXPANDER, SEQ. IIIH
- 3H96040-RAIL RAIL, SEQ. IIIH

Revision DRAFT	Short Block Assembly Piston Installation	Section	5
Jan-15		Sheet	10

Refer to Section 5 Sheet 2 for connecting rod bearing selection.

**Connecting Rod Bearing Selection:**

Check the crankshaft identification codes on the front counterbalance for the connecting rod journal diameter codes and record the data in the appropriate build document.

Using the table in Section 5 Sheet 2, select the appropriate bearings for the connecting rod journal codes (1 - 6) and install the bearing sets in the respective location.

Connecting Rod Shells

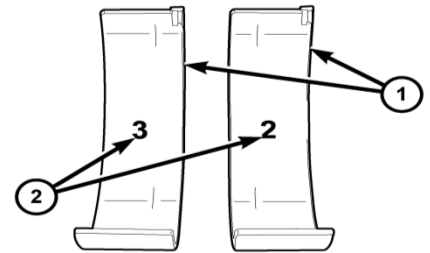

The bearings are available in three different sizes in order to achieve the desired oil clearance.

The connecting rod bearing shells (1) are marked with the bearing size (2) on the bearing lining surface.

**Install rod bearings in pairs, Do Not Mix connecting rod bearing shells**

(1 top 1 bottom) (2 top 2 bottom) (3 top 3 bottom)

Use proper sized piston installation sleeve with piston installation guides to install piston assemblies.

Lubricate the piston rings and piston skirt with EF-411 and slide the piston assembly into the installation sleeve using care to ensure the piston rings are in proper position during installation.



Piston ring installation sleeve with rubber tubing installation guide  
(In-house fabricated)

Revision DRAFT	Short Block Assembly Piston Installation	Section	5
Jan-15		Sheet	11

Position the crankshaft journal at BDC.

Clean the cylinder with a lint free cloth or Teri towel.

Oil the cylinder with EF-411.

Position the piston assembly with the forward identifying mark (1) facing forward on each bank.

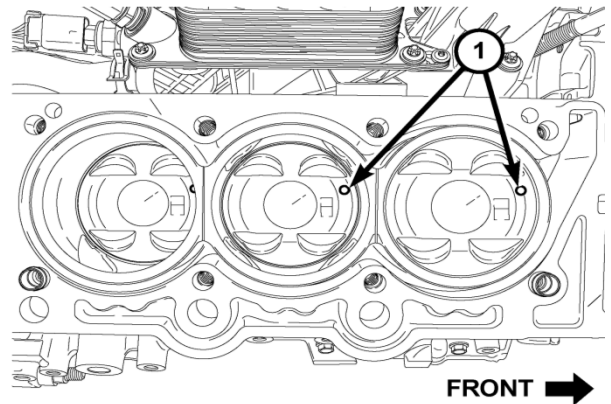

Carefully guide the piston assembly into the cylinder using care not to contact the piston cooling jet.

Position the connecting rod guide in proper alignment with the crankshaft journal.

Ensure the upper connecting rod bearing is in place and lubricate the bearing and rod journal with EF-411.



Revision DRAFT	Short Block Assembly Piston Installation	Section	5
Jan-15		Sheet	12

Hold the piston installation sleeve firmly against the cylinder block deck.  
Using a plastic mallet, tap the piston assembly into the cylinder until the rings completely enter the cylinder.  
Check to ensure the rod bearing is still in the proper position and push the assembly into the cylinder until the rod and bearing seat against the crankshaft journal.



Lubricate the rod cap and lower bearing with EF-411 and install using new connecting rod fasteners.

Tighten the NEW connecting rod cap bolts to 20 N·m (15 ft. lbs.) plus 90°

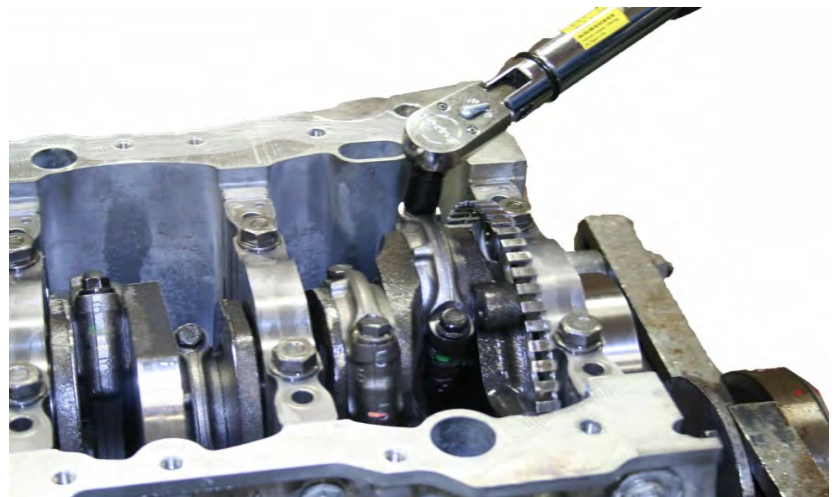

Part Number  
06509128AA Rod Bolt

Revision DRAFT	Long Block Assembly Rear Crankshaft Oil Seal	Section	6
Jan-15		Sheet	1

The rear crankshaft oil seal (2) and retainer (1) are an assembly. To avoid damage to the seal lip, DO NOT remove the seal protector (3) from the rear crankshaft oil seal before installation onto the engine.

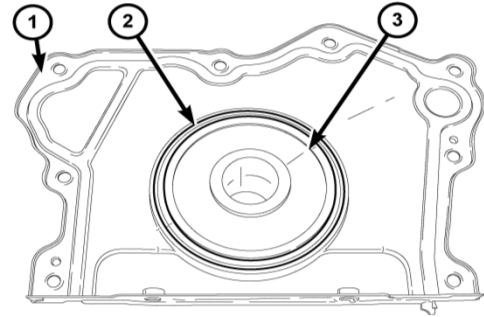

**Note:**

Labs will be reusing the rear cover with the crankshaft oil seal. Labs should purchase some new rear cover assemblies to acquire the pilot guide for installation of the rear cover oil seal assembly.

Part Number:

05184285AF     RETAINER ASM - CRANKSHAFT REAR MAIN OIL SEAL



Carefully position the oil seal retainer assembly and seal protector on the crankshaft and push firmly into place on the engine block.

During this step the seal protector will position the cover and seal assembly by piloting off the rear pilot of the crankshaft. The seal protector will be pushed from the assembly during installation.

Insure the lip seal on the crankshaft is uniformly curled inward and the cover is flush with the oil pan sealing surface.

Install the eight seal retainer bolts and tighten to 12 N·m (106 in. lbs.).

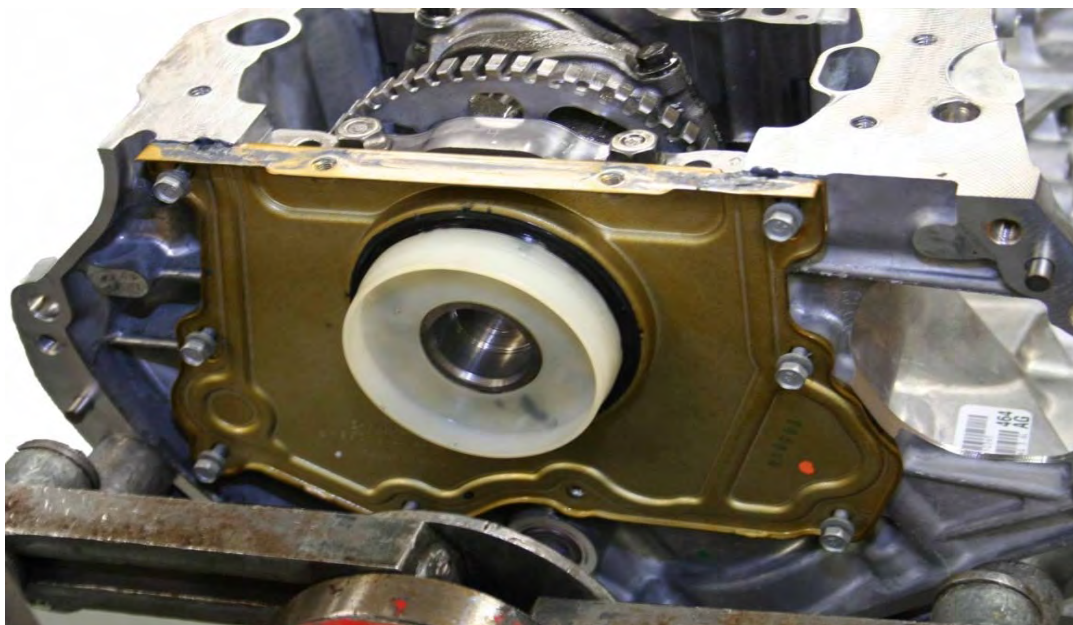

Revision DRAFT	Long Block Assembly Cylinder Head Installation	Section	6
Jan-15		Sheet	2

**CAUTION:**

**Do Not Use Metal Scrapers on Cylinder Deck or Cylinder Head Surfaces.**

Use only plastic type scrapers for cleaning these surfaces.

**WARNING:**

Multi-layered steel head gaskets have very sharp edges and could cause personal injury if not handled properly.

Install new head gaskets every engine build.

## Part Numbers:

05184455AG GASKET - CYLINDER HEAD LH

05184456AG GASKET - CYLINDER HEAD RH

**CAUTION:**

Cylinder head bolt holes are blind holes. Debris such as RTV sealants, coolant, engine oil, or cleaning solvents can cause hydraulic locking and aluminum castings to crank when tightening cylinder head fasteners.

**Make sure cylinder head bolt holes are clean and dry.**

Install both cylinder head gaskets placed firmly over the locating dowels.



Revision DRAFT	Long Block Assembly Cylinder Head Installation	Section	6
Jan-15		Sheet	3

Install the cylinder heads ensuring the heads seat firmly over the locating dowels.

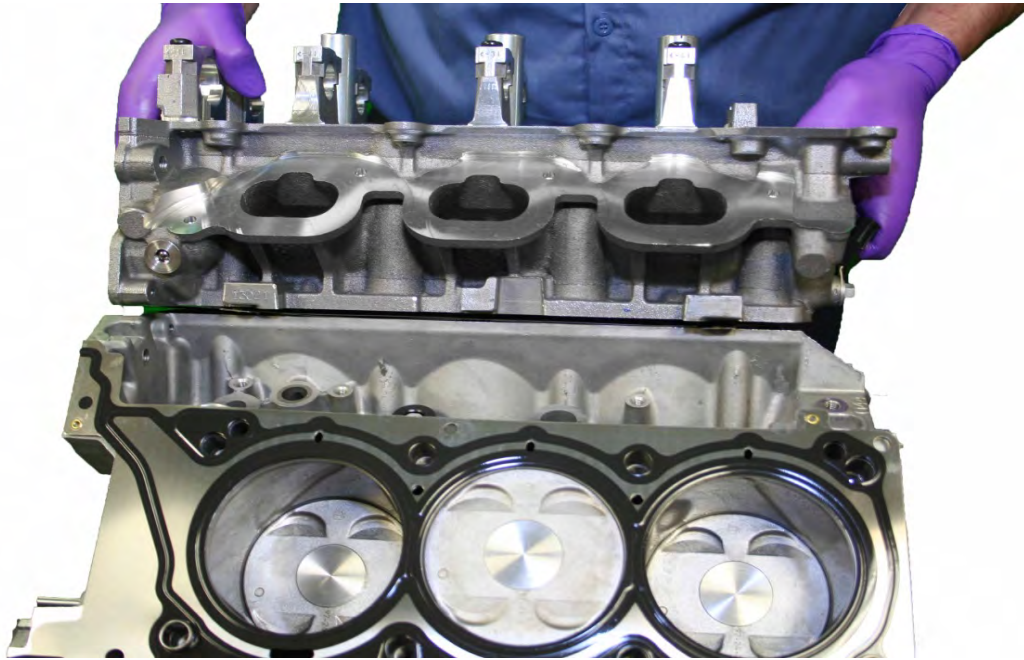

Cylinder head bolts are Yield Type Fasteners.  
Fasteners from the New Engine Disassembly are used for honing with the BHJ Torque Plates.  
New fasteners are use for every test engine build.

Part Number:

**Need Part Numbers**



Lubricate new cylinder head fasteners with EF-411

Allow fasteners to drip free of excess oil and blot with clean Teri towel before inserting into cylinder head.



Tighten the cylinder head fasteners in sequence following this 9 step torque plus angle procedure.

Tighten all fasteners in sequence from the inside out as shown in view A.

Perform each step on all fasteners in sequence

Step 1: 30 N·m (22 ft. lbs.)

Step 2: 45 N·m (33 ft. lbs.)

Step 3: plus 75°

Step 4: plus 50°

Step 5: Loosen all fasteners in reverse order i.e., position 8, 7, 6,... etc.

Step 6: 30 N·m (22 ft. lbs.)

Step 7: 45 N·m (33 ft. lbs.)

Step 8: plus 70°

Step 9: plus 70°

View A

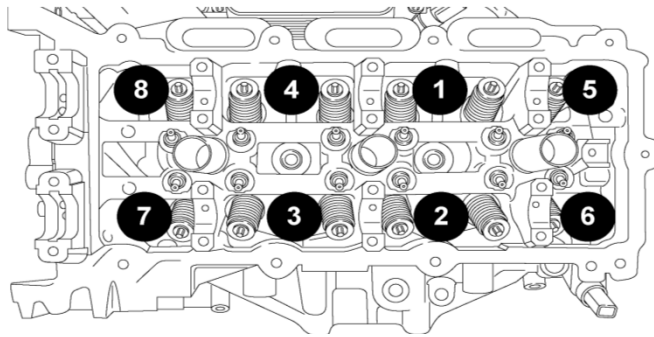

Revision DRAFT	Long Block Assembly Valvetrain Assembly	Section	6
Jan-15		Sheet	5

Before installing any valvetrain gear, position the crankshaft on TDC #1 by aligning the dimple (2) on the crankshaft with the block / bearing cap junction (1).

Ensure the crankshaft drift key is positioned in the key way cut in the crankshaft (3).

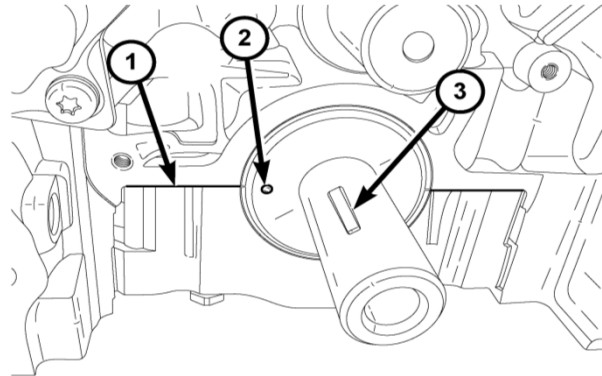

**CAUTION:**

**Do Not Rotate the Crankshaft or Camshafts any further than directed in the timing chain installation procedure from this point forward as bent valves will result.**

Lubricate the lash adjusters and roller rockers with EF-411 and install in 24 positions on the cylinder heads.

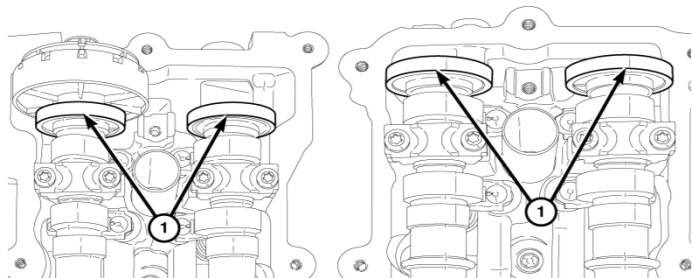

**CAUTION:**

The magnetic timing wheels (1) must not come in contact with magnets (pickup tools, trays, etc.) or any other strong magnetic field. This will destroy the timing wheels ability to correctly relay camshaft position to the camshaft position sensor.

Remove the production phasers from the intake and exhaust camshafts.

Lubricate the OHT Fixed Phasers and the nose of the intake and exhaust camshafts.

Install the OHT Fixed Phasers on the intake and exhaust camshafts and hand tighten the oil control valves.



Remove the camshaft bushing caps from the cylinder heads.

Lubricate the camshaft journals with EF-411 and install all four camshafts in their neutral load positions.

#### Right Side

Install the right side camshaft(s) at top-dead-center by positioning the alignment holes (1) vertically. This will place the camshafts at the neutral position (no valve load) easing the installation of the camshaft bearing caps.

Install the camshaft bearing caps and hand tighten the retaining bolts to 2 N·m (18 in. lbs.).

Caps are identified numerically (1 - 4), intake or exhaust (I or E) and should be installed from the front to rear of engine. All caps should be installed with the notch forward so that the stamped arrows (<) on the caps point toward the front of the engine.

Tighten the bearing cap retaining bolts in the sequence shown to 9.5 N·m (84 in. lbs.).

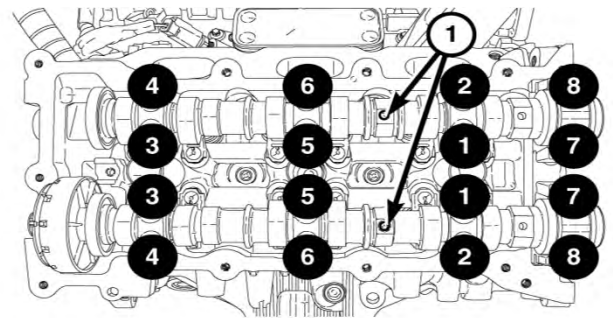
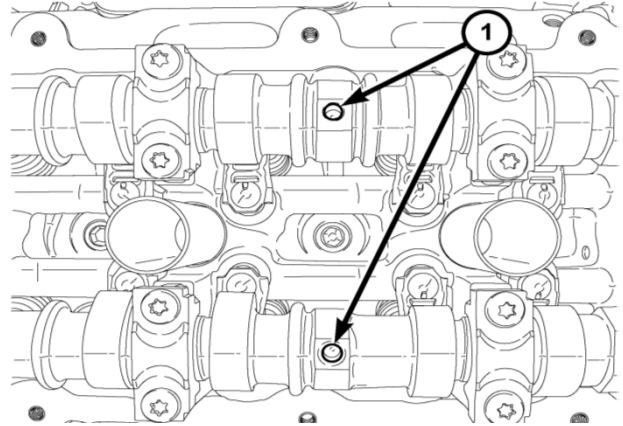

TDC Neutral Load Alignment (Holes Vertical)

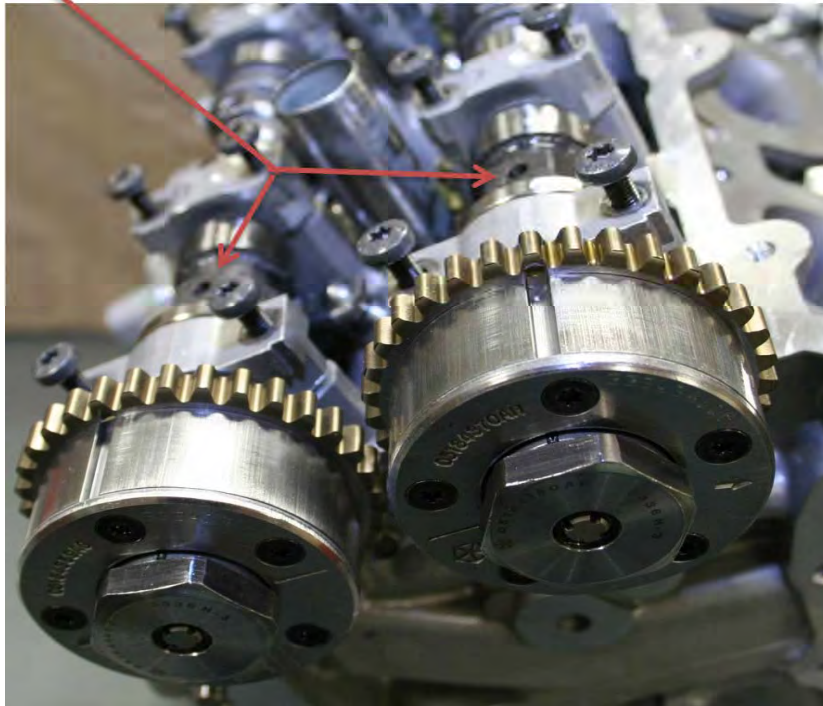

Remove the camshaft bushing caps from the cylinder heads.

Lubricate the camshaft journals with EF-411 and install all four camshafts in their neutral load positions.

Install the left side camshaft(s) with the alignment holes (1) positioned approximately 30° before top-dead-center.

This will place the camshafts at the neutral position (no valve load) easing the installation of the camshaft bearing caps.

Install the camshaft bearing caps and hand tighten the retaining bolts to 2 N·m (18 in. lbs.).

Caps are identified numerically (1 - 4), intake or exhaust (I or E) and should be installed from the front to rear of engine. All caps should be installed with the notch forward so that the stamped arrows (<) on the caps point toward the front of the engine.

Tighten the bearing cap retaining bolts in the sequence shown to 9.5 N·m (84 in. lbs.).

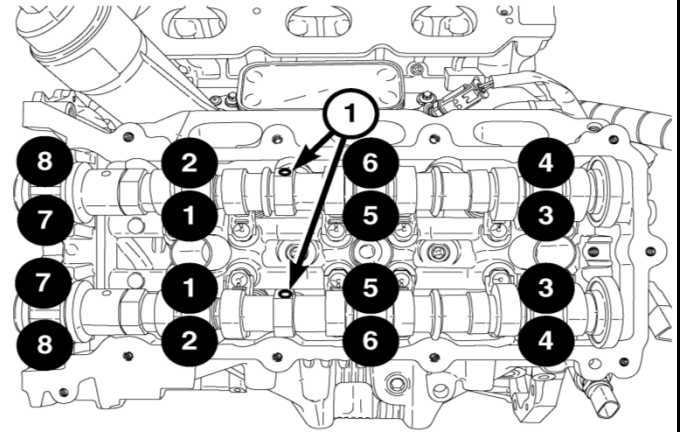

TDC Neutral Load Alignment (Holes ~ 30° BTDC)

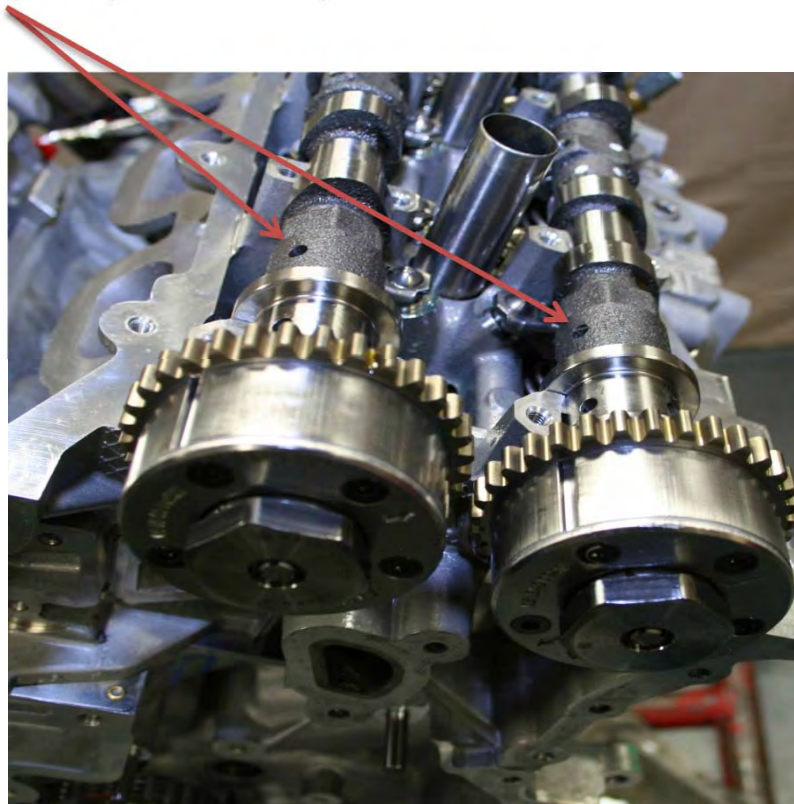

Revision DRAFT	Long Block Assembly Timing Drive Description	Section	6
Jan-15		Sheet	8

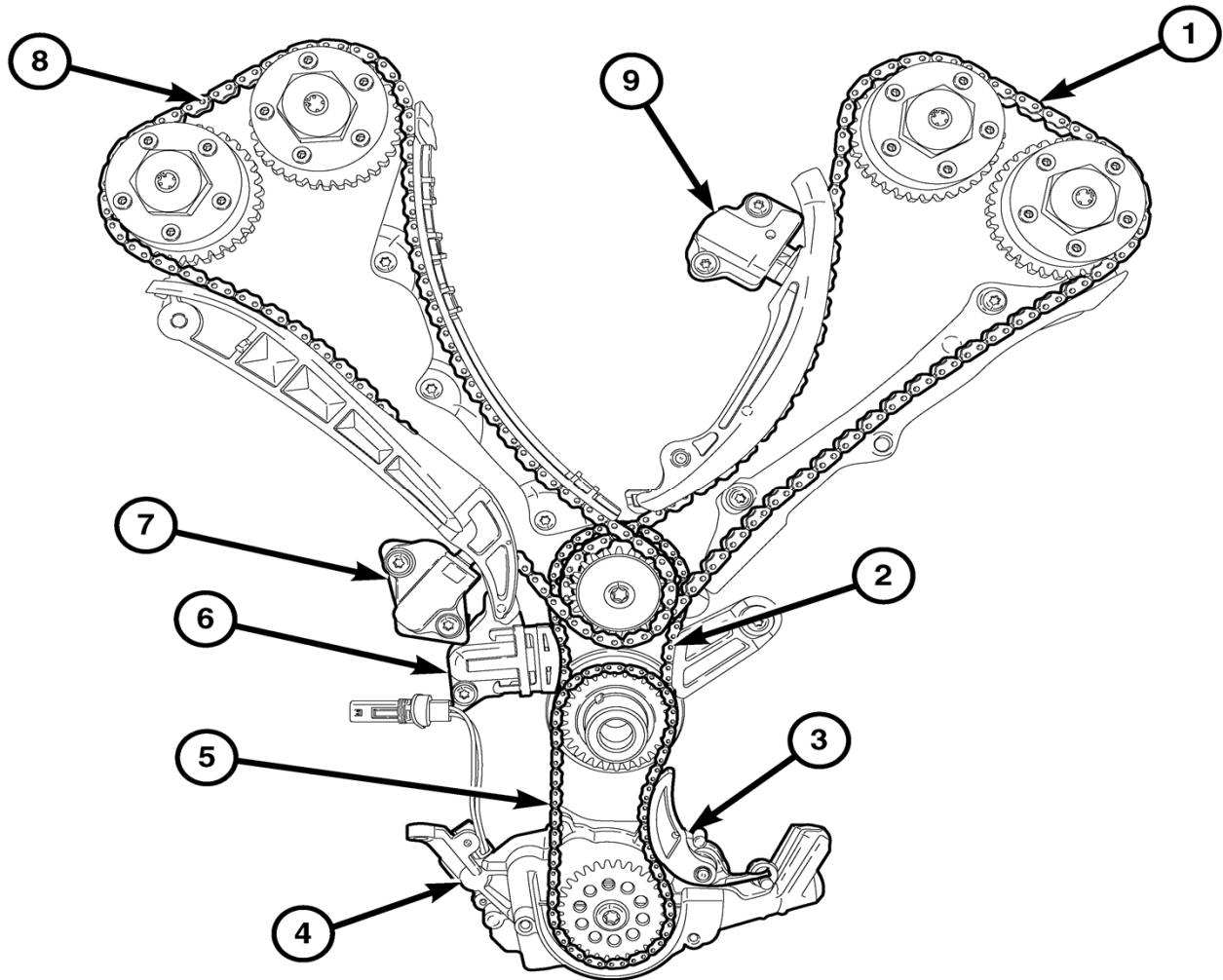

The timing drive uses four silent chains. The silent chain link design improves sprocket engagement and reduces noise, vibration and harshness (NVH). One chain (5) drives the oil pump (4) and three chains drive the camshafts in a two stage design. The left secondary camshaft chain (1) uses an oil pressure controlled chain tensioner (9) with a ratcheting device. The right secondary camshaft chain (8) uses an oil pressure controlled tensioner (7) without a ratchet. The primary chain (2) also uses an oil pressure controlled tensioner (6) without a ratchet. A spring loaded tensioner (3) takes up the slack in the oil pump chain (5). The chain guides and tensioner arms are made of glass filled nylon with nylon wear faces

**Resetting the left side chain tensioner**

The slot (2) in the rack provides an anchor point for a pin that holds the rack in the retracted position.

- 1 Using a suitable tool, such as an allen wrench (1), lift the pawl off of the rack.
- 2 While holding the pawl off of the rack, push the rack and the piston into the tensioner body.
- 3 When the slot is aligned with the hole in the tensioner body, insert Tensioner Pin 8514 (1) to hold the rack and piston in the retracted position.

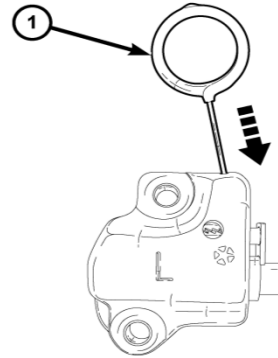
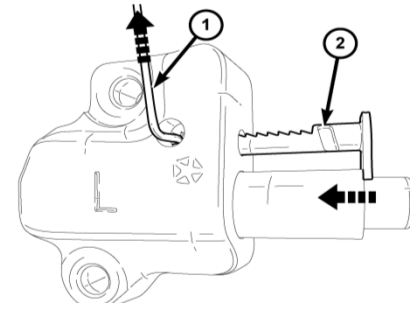
**Installing the camshaft phaser locks**

- 1 Rotate the crankshaft counter clockwise to a position 30° before-top-dead-center. View A

**Note:**

It may be necessary to rock the camshaft slightly (a few degrees) with a wrench (4) when installing the camshaft phaser locks.

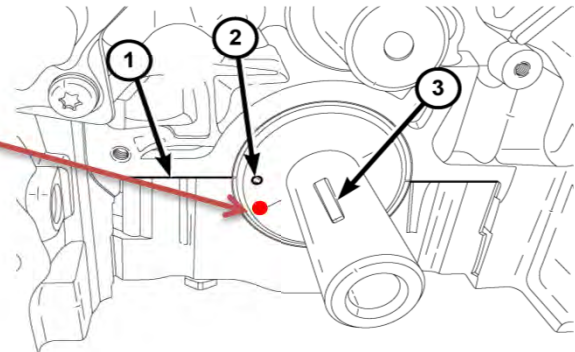
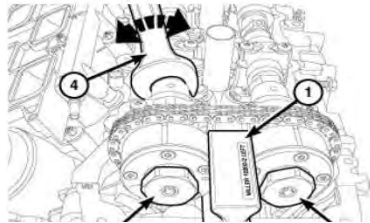

- 2 Install the right side phaser lock 10202-1 with the tool number facing up.
- 3 Install the left side phaser lock 10202- 2 with the tool number facing up.
- 4 Rotate the crankshaft clockwise back to top-dead-center after installing the camshaft phaser locks (2) the camshaft phaser locks (2) shown in View A.

Right Side  
10202 - 1



Left Side  
10202 - 2

- 1 Place the primary chain onto the crankshaft sprocket (3) so that the arrow (2) is aligned with the plated link (1) on the timing chain.

View from back side

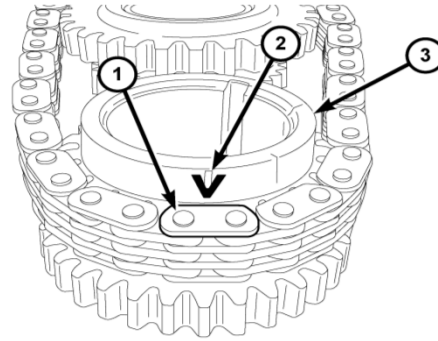

- 2 While maintaining this alignment, invert the crankshaft sprocket and timing chain and place the idler sprocket (4) into the timing chain so that the dimple (2) is aligned with the plated link (1) on the timing chain.

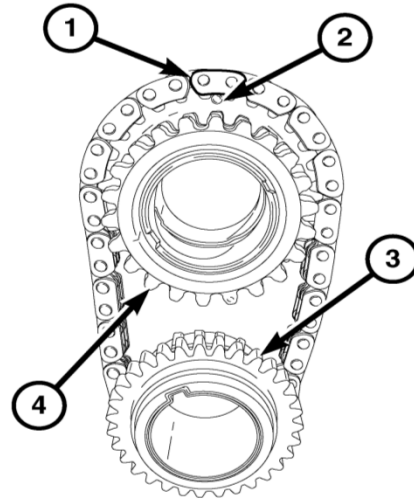

- 3 While maintaining this alignment, lubricate the idler sprocket bushing with clean engine oil and install the sprockets and timing chain on the engine. To verify that the timing is still correct, the timing chain plated link (6) should be located at 12:00 (1) when the dimple (5) on the crankshaft is aligned with the block/bearing cap junction (4).

- 4 Install the idler sprocket retaining bolt (2) and washer (3). Tighten the T45 bolt (2) to 25 N·m (18 ft. lbs.).

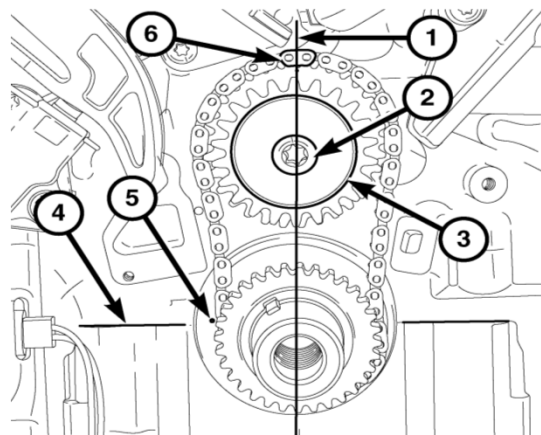

5 Install the primary chain guide (2). Tighten attaching T30 bolt (1) to 12 N·m (106 in. lbs.).

6 Reset the primary chain tensioner (5) by pushing back the tensioner piston and installing Tensioner Pin 8514 (3).

7 Install the primary chain tensioner (5) to the engine block with two bolts (4). Tighten the T30 bolts (4) to 12 N·m (106 in. lbs.) and remove the Tensioner Pin 8514 (3).

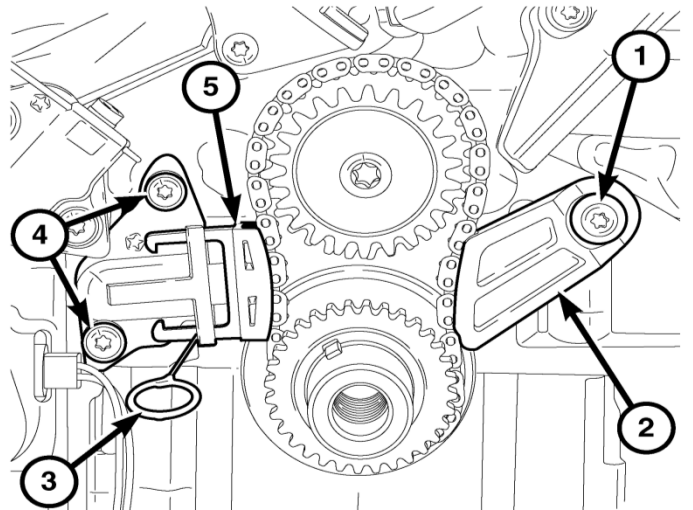

8 Install the right side cam chain guide (1) and tensioner arm (6). Tighten attaching T30 bolts (2) to 12 N·m (106 in. lbs.).

9 Install the right side cam chain tensioner (3) to the engine block with two bolts (4). Tighten the T30 bolts (4) to 12 N·m (106 in. lbs.).

10 Reset the right side cam chain tensioner (3) by pushing back the tensioner piston and installing Tensioner Pin 8514 (5).

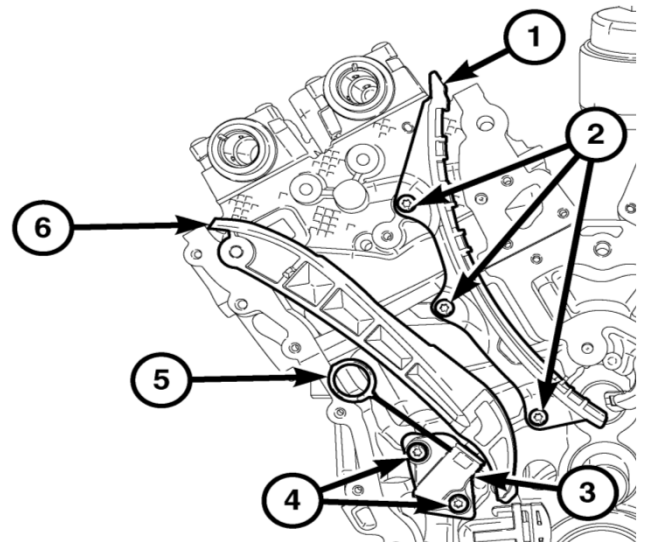

11 Install the left side cam chain guide (2) and tensioner arm (1). Tighten attaching T30 bolts (4) to 12 N·m (106 in. lbs.).

12 Install the left side cam chain tensioner (5) to the cylinder head with two bolts (6). Tighten the T30 bolts (6) to 12 N·m (106 in. lbs.).

13 Reset the left side cam chain tensioner (5) by lifting the pawl (3), pushing back the piston and installing Tensioner Pin 8514 (7)

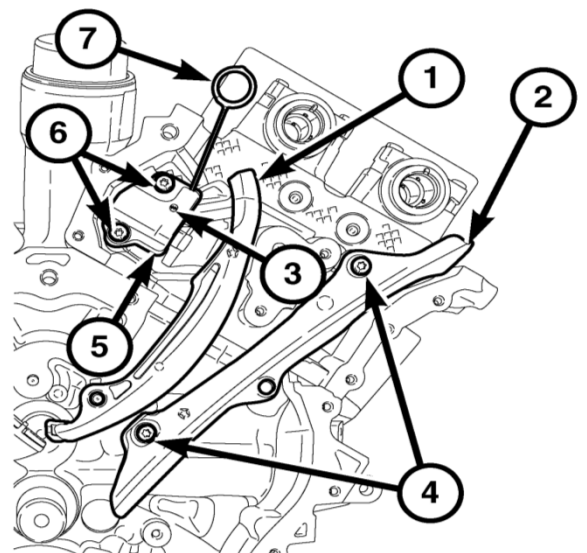



- 1 Drape the left side cam chain over the left side intake cam phaser and onto the idler sprocket (1) so that the arrow (3) is aligned with the plated link (2) on the cam chain.

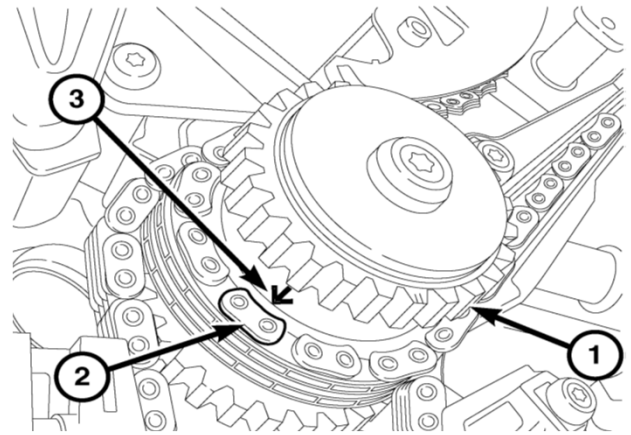

- 2 While maintaining this alignment, route the cam chain around the exhaust and intake cam phasers so that the plated links are aligned with the phaser timing marks (1). Position the left side cam phasers so that the arrows (3) point toward each other and are parallel to the cylinder head cover mounting surface (5). Press the exhaust cam phaser onto the exhaust cam, install and hand tighten the oil control valve (2).

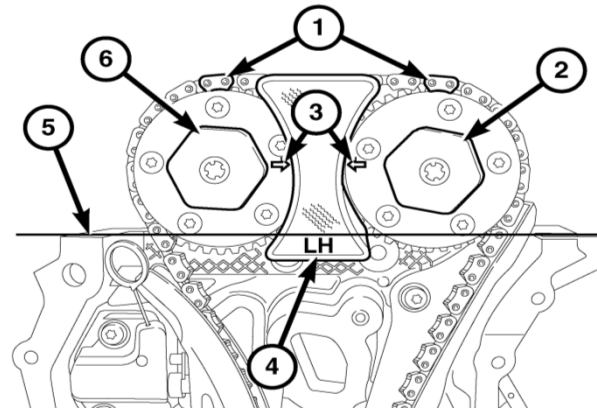

- 3 Drape the right side cam chain over the right side exhaust cam phaser and onto the idler sprocket (1) so that the dimple (2) is aligned with the plated link (3) on the cam chain.

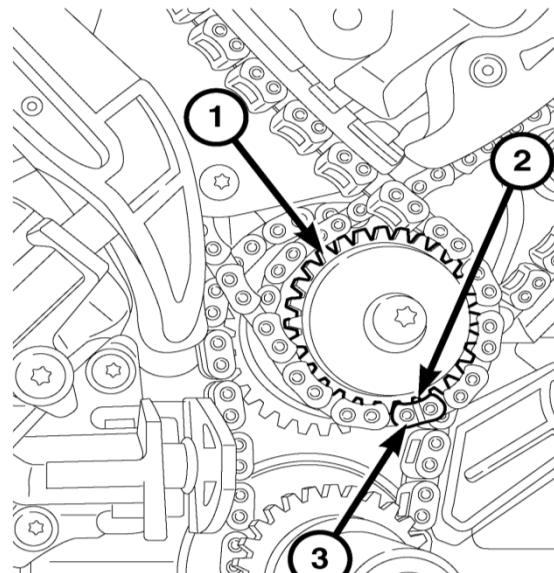

4 While maintaining this alignment, route the cam chain around the exhaust and intake cam phasers so that the plated links are aligned with the phaser timing marks (1). Position the right side cam phasers so that the arrows (3) point away from each other and the scribe lines (4) are parallel to the cylinder head cover mounting surface (6). Press the intake cam phaser onto the intake cam, install and hand tighten the oil control valve (2).

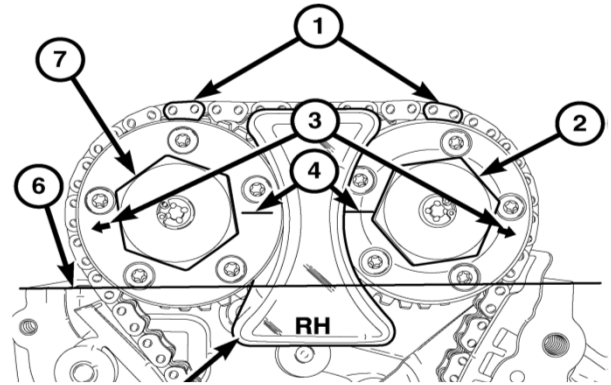

5 Tighten all four oil control valves to 150 N·m (110 ft. lbs.).

6 Remove all phaser locks and tensioner lock pins.

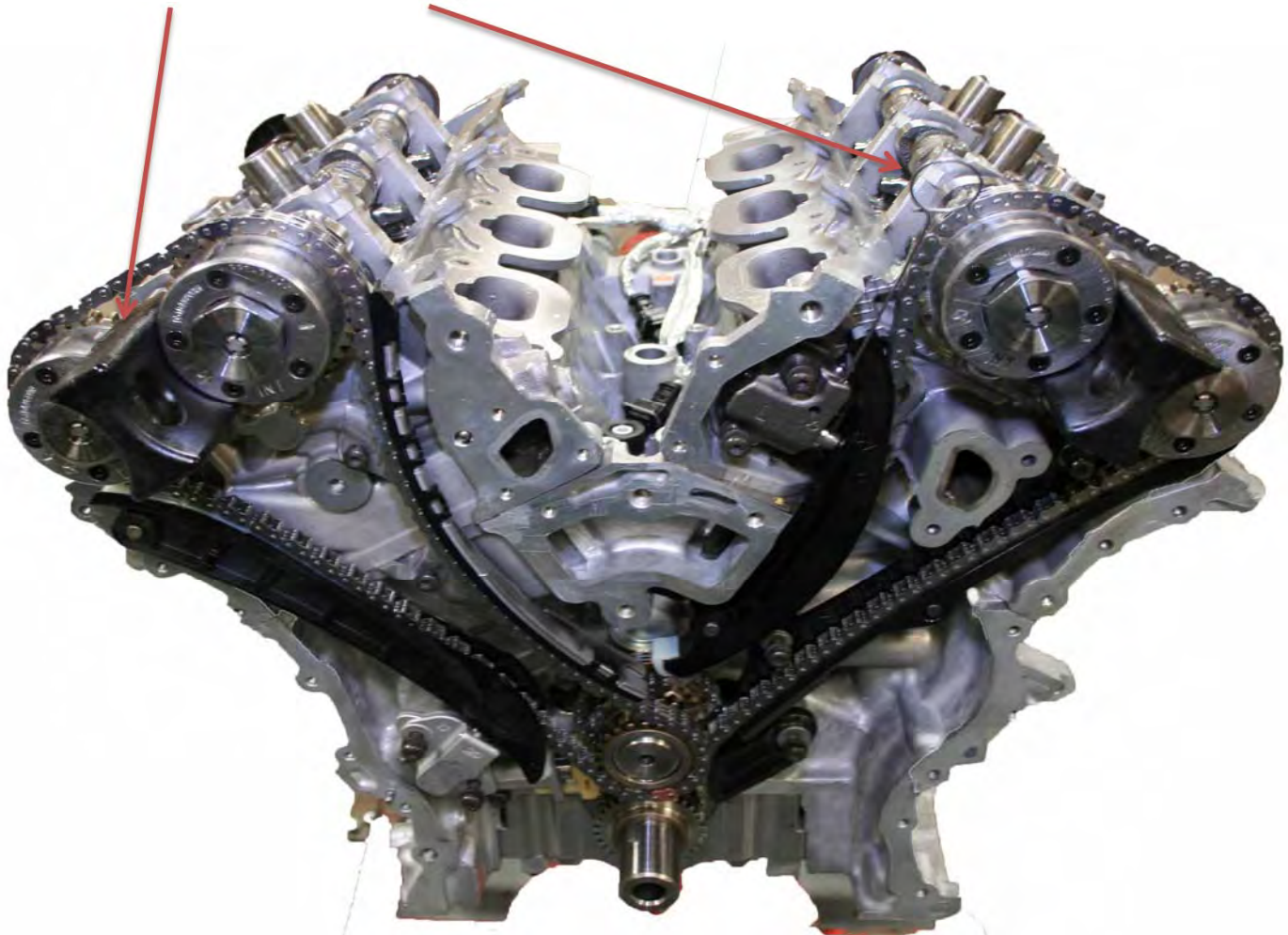

- 1 Install the windage tray with eight main bearing cap bolts. Tighten the bolts in the sequence shown to 21 N·m (16 ft. lbs.) plus 90°.

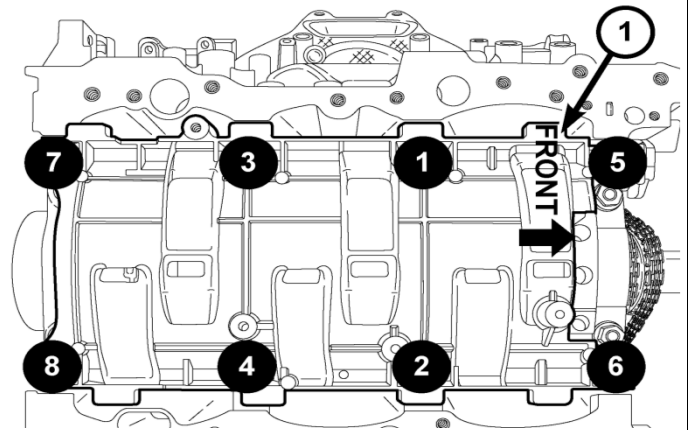

- 2 Align the locator pins (2) to the engine block and install the oil pump (3) with four bolts (1). Tighten the bolts to 12N·m (106 in. lbs.).

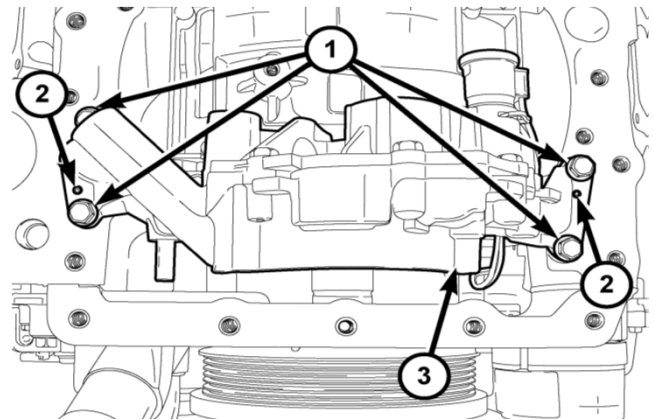

- 3 Install the oil pump chain tensioner on the oil pump.

- 4 Position the oil pump chain tensioner spring (1) above the dowel pin (2).

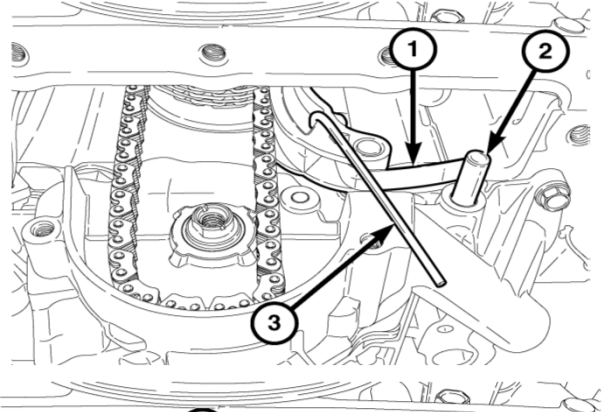

- 5 Push back the oil pump chain tensioner and insert a suitable retaining pin (3) such as a 3 mm Allen wrench.

- 6 Place the oil pump sprocket (4) into the oil pump chain (3). Align the oil pump sprocket with the oil pump shaft and install the sprocket. Install the T45 retaining bolt (2) and tighten to 25 N·m (18 ft. lbs.).

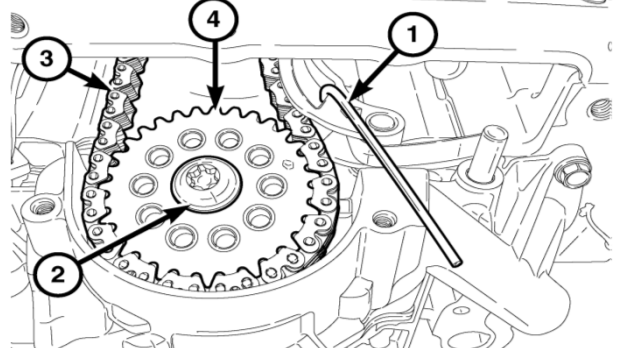

- 7 Remove the retaining pin (1). Verify that the oil pump chain is centered on the tensioner and crankshaft sprocket.

- 8 Rotate the crankshaft CW one complete revolution to verify proper oil pump chain installation.

Revision DRAFT	Final Dress RTV Sealant	Section	7
Jan-15		Sheet	1

**CAUTION:**

Do not use oil based liquids, wire brushes, abrasive wheels or metal scrapers to clean the engine gasket surfaces. Use only isopropyl (rubbing) alcohol, along with plastic or wooden scrapers. Improper gasket surface preparation may result in engine fluid leakage.

**CAUTION:**

Engine assembly requires the use of a unique sealant that is compatible with engine oil. Using a sealant other than Mopar Threebond Engine RTV Sealant may result in engine fluid leakage.

**CAUTION:**

Following the application of Mopar Threebond Engine RTV Sealant to the gasket surfaces, the components must be assembled within 20 minutes and the attaching fasteners must be tightened to specification within 45 minutes. Prolonged exposure to the air prior to assembly may result in engine fluid leakage.



Revision DRAFT	Final Dress Front Cover	Section	7
Jan-15		Sheet	2

- 1 Remove all residual sealant from the timing chain cover, cylinder head and engine block mating surfaces (1), (2), (3), & (4).

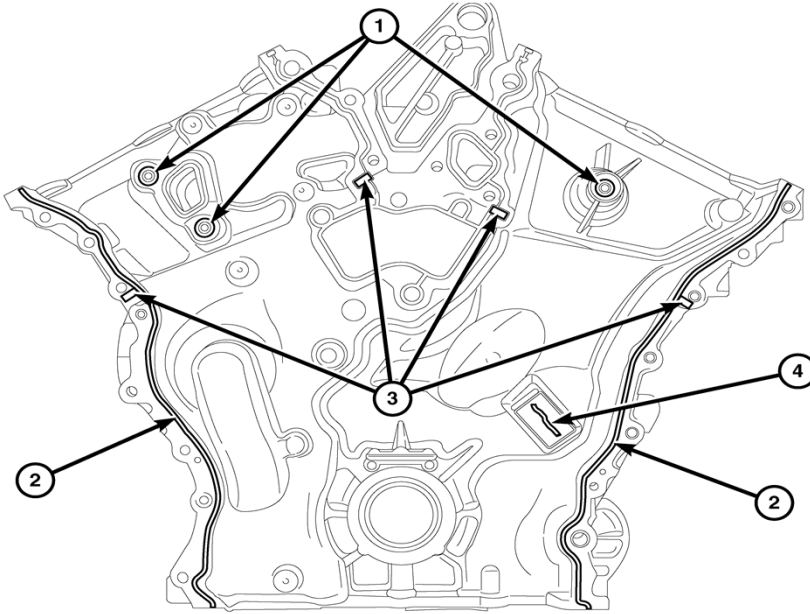

- 2 Inspect the coolant outlet housing gasket (1) and the water pump gasket (2). Replace if necessary.

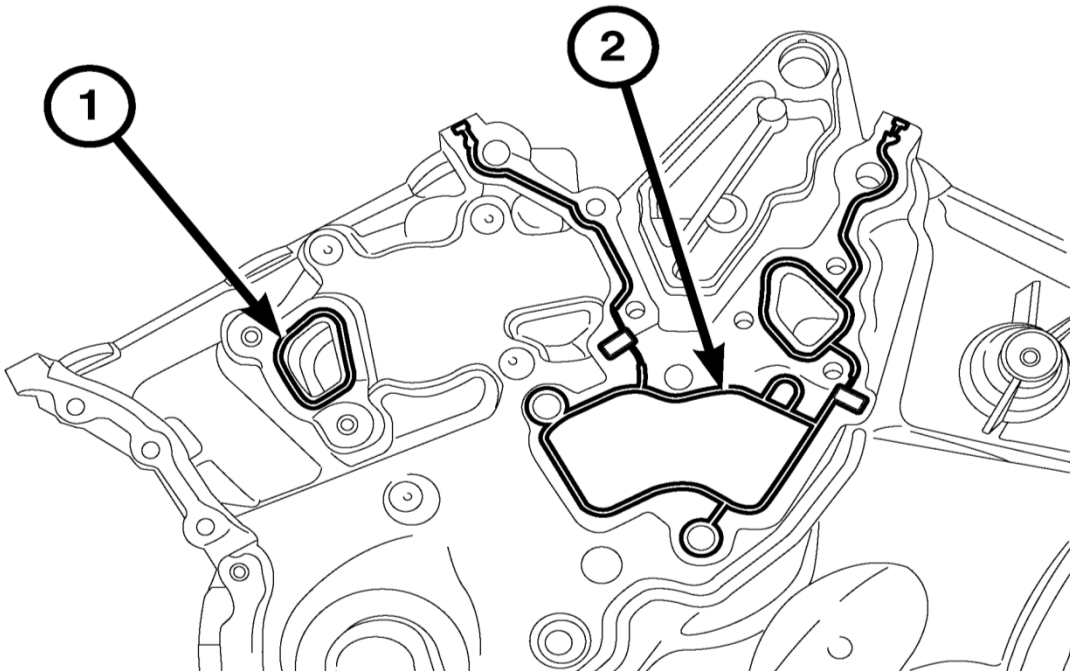

Revision DRAFT	Final Dress Front Cover	Section	7
Jan-15		Sheet	3

1 Clean the engine timing cover, cylinder head and block mating surfaces with isopropyl alcohol in preparation for sealant application.

2 Apply a 2 to 3 mm wide bead of Mopar Threebond Engine RTV Sealant to the front cover as shown in the following locations:

- Three cylinder head bosses (1)
- Right and left flanges (2)
- Four cylinder head to engine block T-joints (3)
- Cover to right cam chain tensioner gap (4)

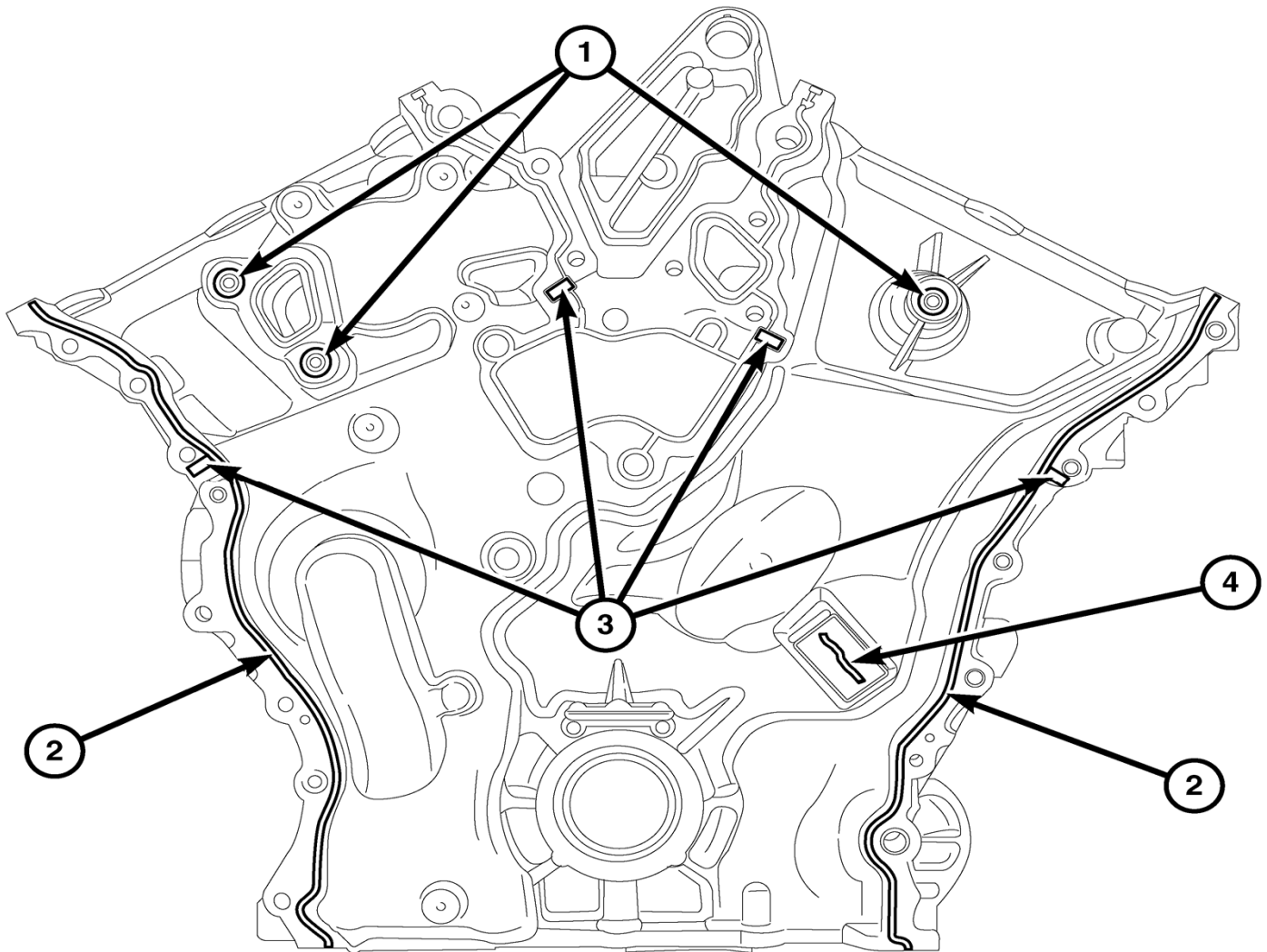

Revision DRAFT	Final Dress Front Cover	Section	7
Jan-15		Sheet	4

- 1 Align the locator pins (5) on the engine block to the engine timing cover and install the cover.
- 2 Install twenty-two M6 bolts (3) and one M8 bolt (4). Tighten the M6 bolts (3) to 12 N·m (106 in. lbs.) and the M8 bolt (4) to 25 N·m (18 ft. lbs.).

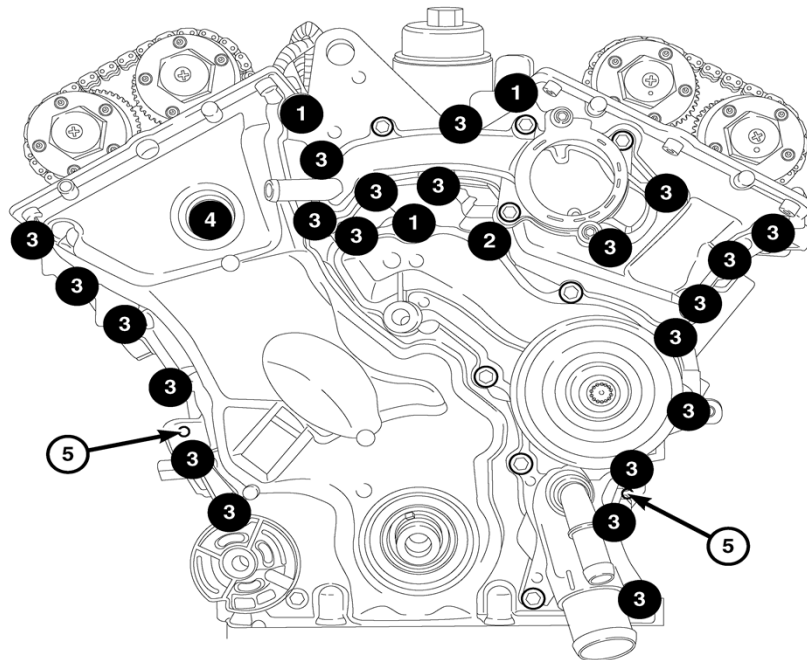

Replace coolant cross over and water pump with OHT materials when available.



Revision DRAFT	Final Dress Upper Oil Pan	Section	7
Jan-15		Sheet	5

1 See Section 7 Sheet 1 for cleaning and RTV usage guidelines.

2 Clean all sealing areas of the upper oil pan and prepare for installation.

3 Apply a 2 to 3 mm wide bead of Mopar Threebond Engine RTV Sealant to the upper oil pan as shown in the following locations:

- Oil pan to engine block flange (1)
- Two timing cover to engine block T-joints (2)
- Two rear seal retainer to engine block T-joints (3)

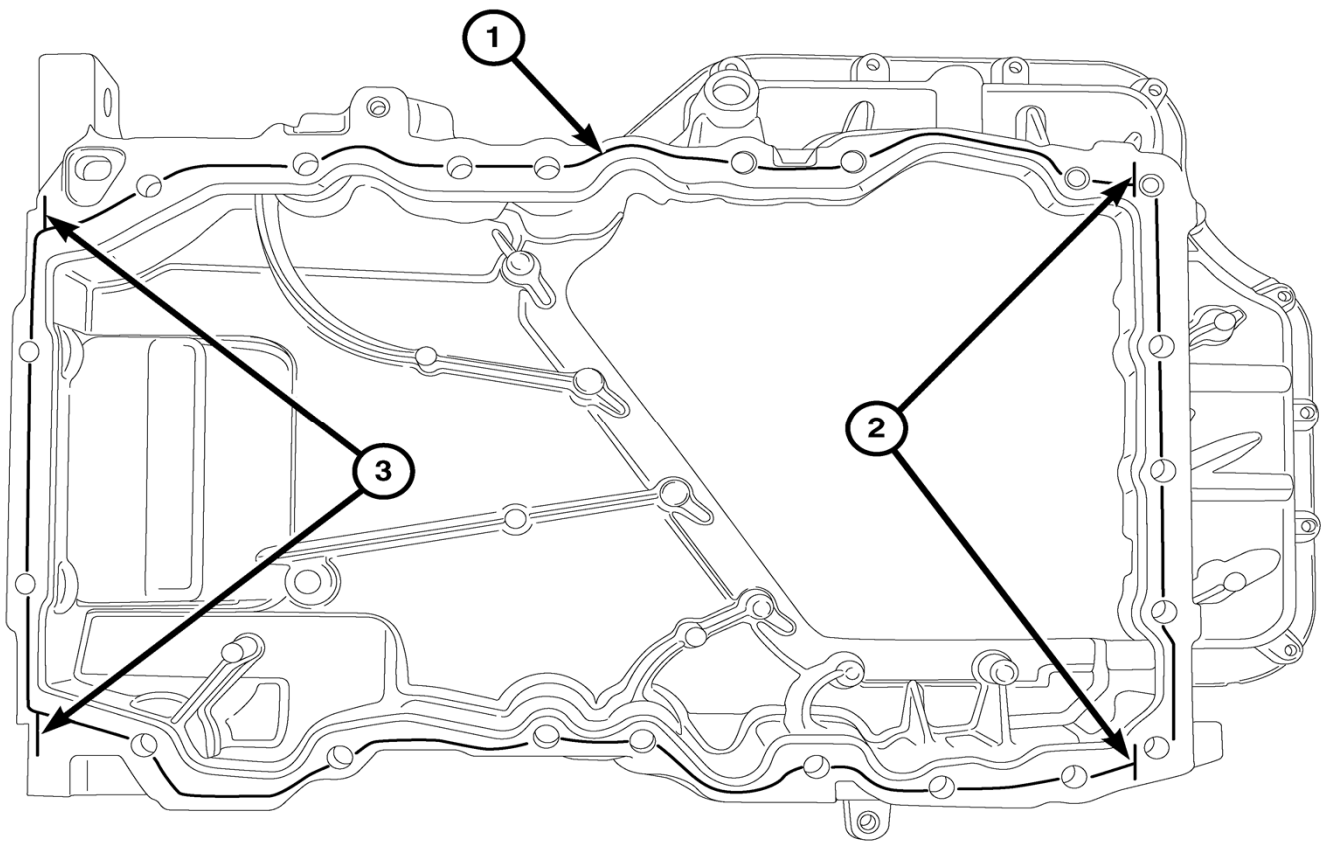



Revision DRAFT	Final Dress Upper Oil Pan	Section	7
Jan-15		Sheet	6

**CAUTION:**

Make sure that the rear face of the oil pan is flush to the transmission bell housing before tightening any of the oil pan mounting bolts. A gap between the oil pan and the rear mount could crack the oil pan casting.

- 1 Install the oil pan to the engine block and flush to the transmission bell housing. Secure the oil pan to the engine block with nineteen M8 oil pan mounting bolts (1) finger tight.
- 2 Tighten the nineteen previously installed M8 oil pan mounting bolts to 25 N·m (18 ft. lbs.).

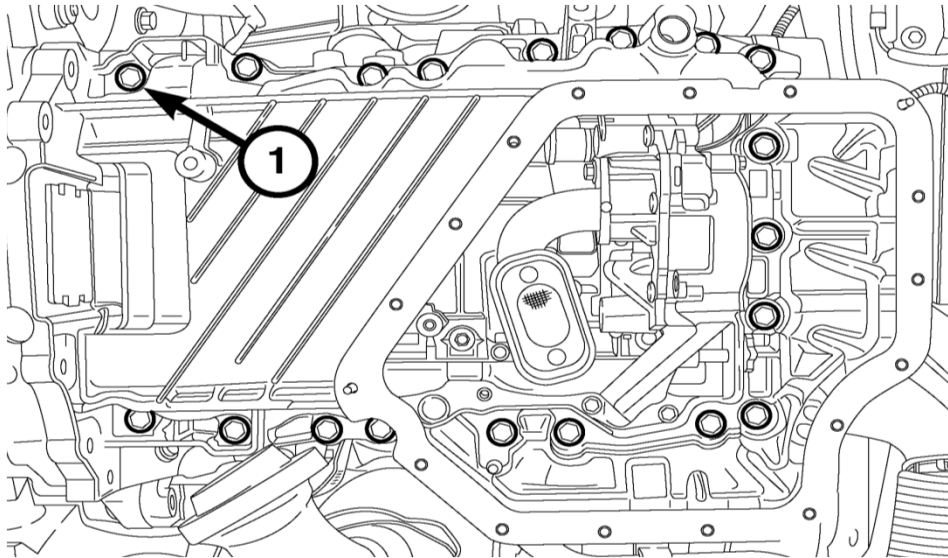

View is shown with transmission attached in vehicle

- 3 Install the two M6 bolts (1) to the rear oil seal retainer flange and tighten to 12 N·m (9 ft. lbs.).

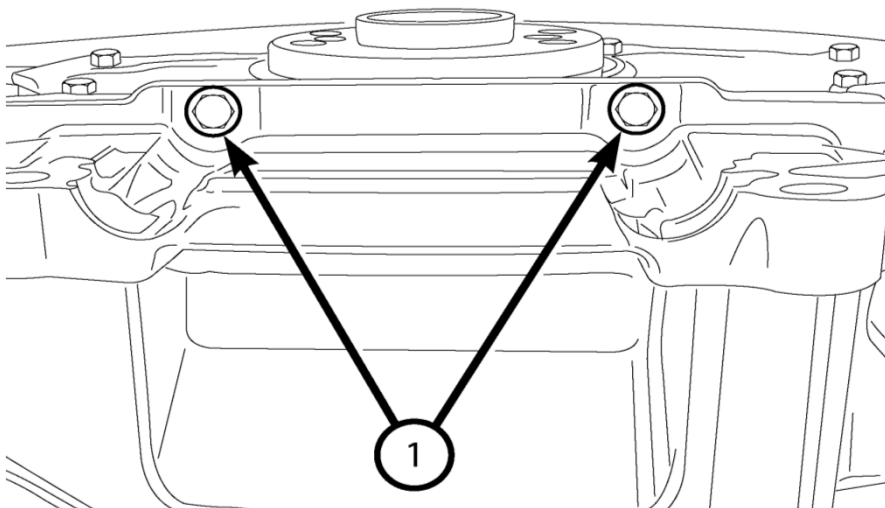

Revision DRAFT	Final Dress Lower Oil Pan	Section	7
Jan-15		Sheet	7

See Section 7 Sheet 1 for cleaning and RTV usage guidelines.

- 1 Clean the upper and lower oil pan mating surfaces with isopropyl alcohol in preparation for sealant application.
- 2 Apply a 2 to 3 mm wide bead of Mopar Threebond Engine RTV Sealant (1) to the lower oil pan as shown.
- 3 Install the lower oil pan to the upper oil pan with fifteen bolts (1) and tighten to 11 N·m (97 in. lbs.).

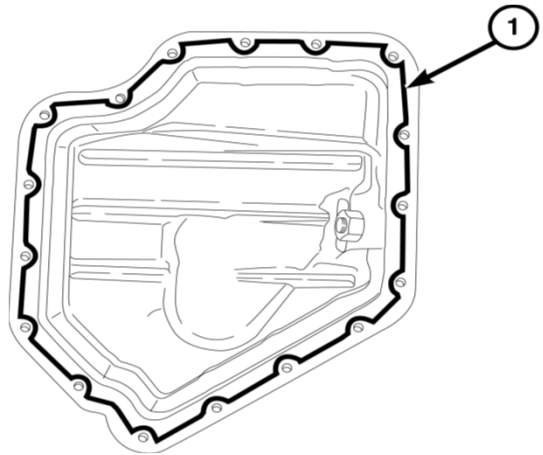

Revision DRAFT	Final Dress Camshaft Covers	Section	7
Jan-15		Sheet	8

**CAUTION:**

Do not use oil based liquids, wire brushes, abrasive wheels or metal scrapers to clean the engine gasket surfaces. Use only isopropyl (rubbing) alcohol, along with plastic or wooden scrapers. Improper gasket surface preparation may result in engine fluid leakage.

**CAUTION:**

The magnetic timing wheels (1) must not come in contact with magnets (pickup tools, trays, etc.) or any other strong magnetic field. This will destroy the timing wheels ability to correctly relay camshaft position to the camshaft position sensor.

- 1 Remove all residual sealant (1) from the cylinder head, timing chain cover and cylinder head cover mating surfaces
- 2 Apply a 2 to 3 mm wide bead of Mopar Threebond Engine RTV Sealant (1) to the two engine timing cover to cylinder head T-joints as shown.
- 3 Align the locator pins (1) to the cylinder head and install the cylinder head cover.
- 4 Tighten the cylinder head cover bolts and double ended studs in the sequence shown to 12 N·m (106 in. lbs.).

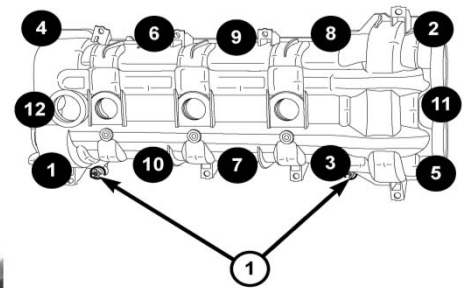
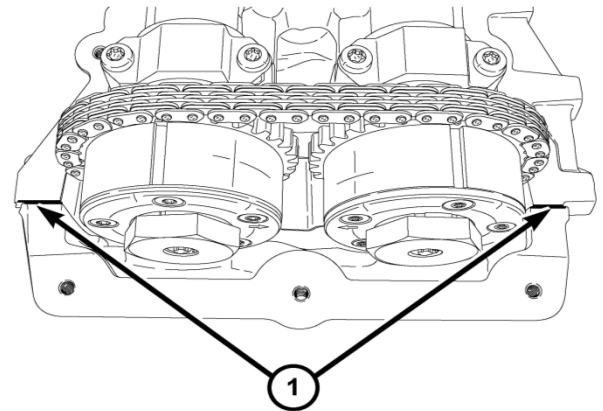
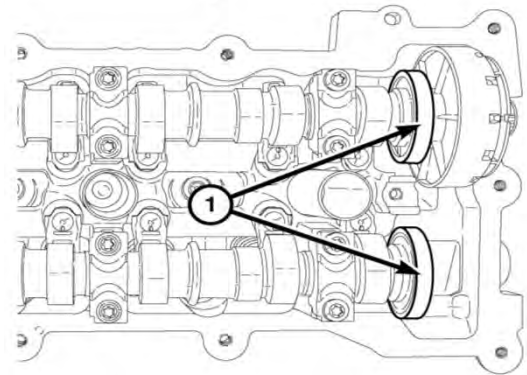

Revision DRAFT	Final Dress PCV Valve	Section	7
Jan-15		Sheet	9

The Crankcase Ventilation Valve must be modified for test. Using a M12 1.75 Tap threaded into the bushing about 4 threads, that holds the Valve, Spring, and Washer inside the PCV Housing. Clamp the tap into a vise and lightly tap on the housing with a plastic mallet to pull the bushing out and remove the insides.

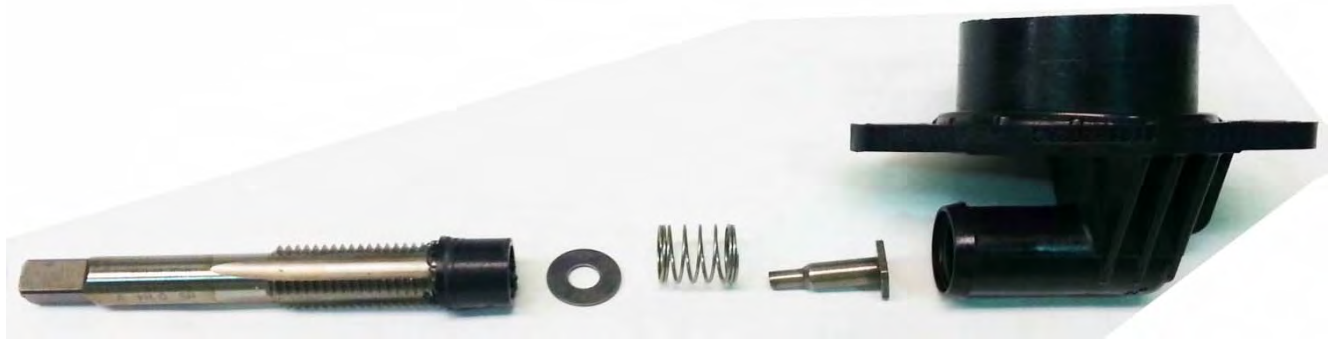

1 Install the empty PCV Housing (1) in the rear of the right camshaft cover aligning the inner lip seal with the right side exhaust camshaft and fasten using the three fasteners (2)

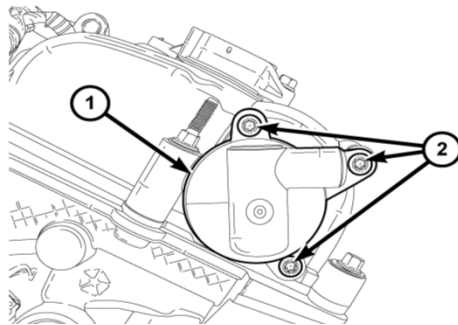

Revision DRAFT	Final Dress Cam Sensors / Coils	Section	7
Jan-15		Sheet	10

1 Install both the left and right camshaft position sensors.

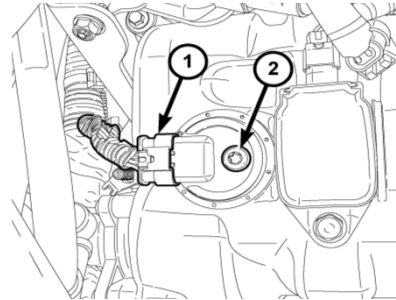

**NOTE:**

Spark Plugs and Ignition Coils may be installed at the test stand.

2 Install the spark plugs and ignition coils.

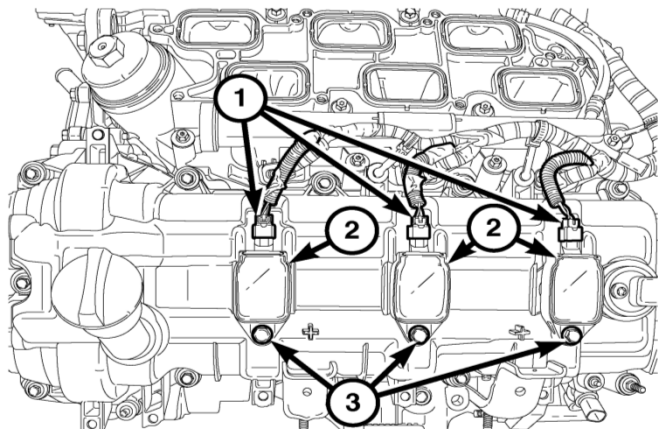

3 If removed, Install the variable valve timing solenoids.

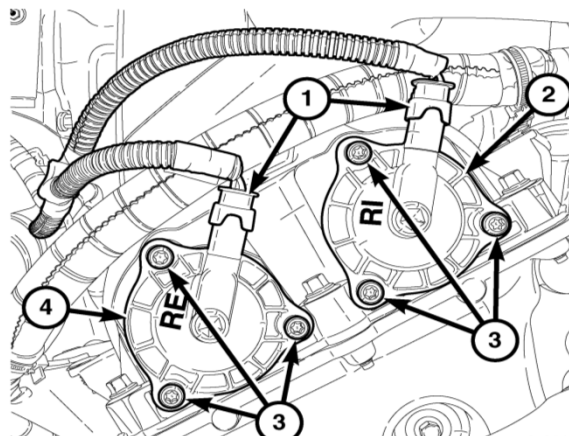

Revision DRAFT	Final Dress Oil Cooler	Section	7
Jan-15		Sheet	11

1 Install new oil filter housing seals (2) onto the oil filter housing.

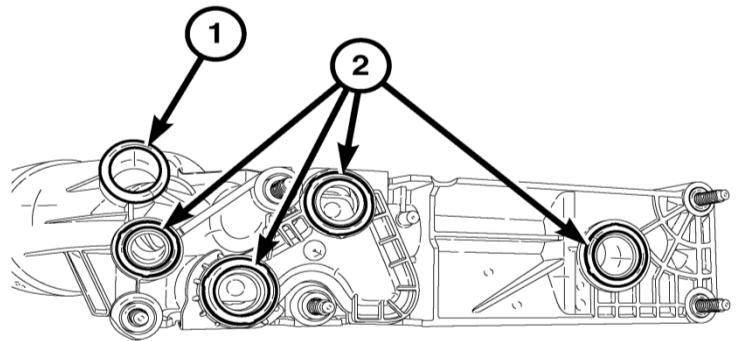

2 Position the oil filter housing (1) on the engine block.

3 Install five bolts and tighten in the sequence shown to 12 N·m (106 in. lbs.).

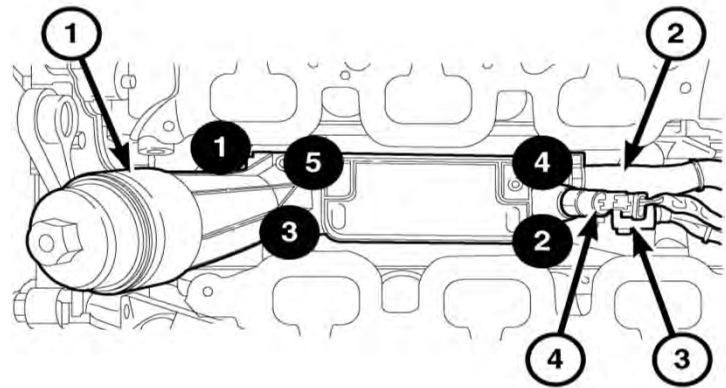

**Note:**

Labs must install the oil filter and charge the engine with test oil before starting engine.

Revision DRAFT	Final Dress Lower Intake	Section	7
Jan-15		Sheet	12

- 1 Check the lower intake manifold assembly to ensure the fuel rail and injectors are installed and the seals are all in tack and clean. Ensure there are no debris inside the assembly.
- 2 Position the lower intake manifold (1) on the cylinder head surfaces
- 3 Install the manifold attaching bolts and tighten in the sequence shown to 8 N·m (71 in. lbs.).

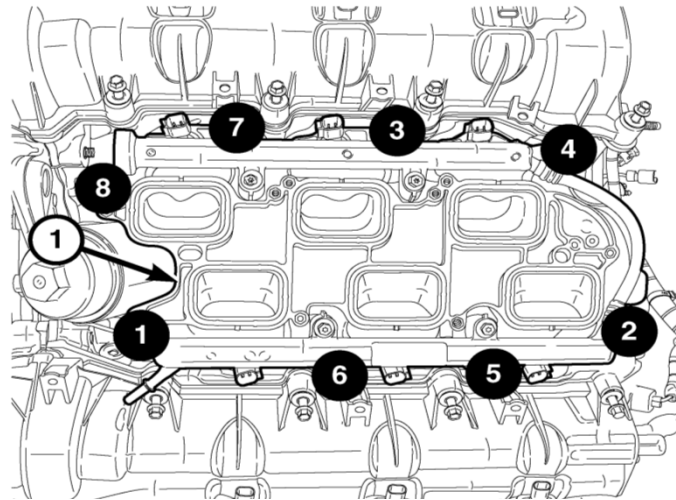

- 4 Cover the inlet ports with tape or install the upper intake assembly depending on lab practices.
- 5 Install the upper intake manifold (1), support brackets and resonator leaving the insulated pad out ( the insulated pad for NVH is not used in testing).

**CAUTION:**

The upper intake manifold fasteners are screw type and self thread into the lower intake. Operators and build technicians must exercise care during tightening. If the fasteners are striped, a new lower intake must be used.

