

Sequence IIIG Test Procedure

Draft Number 2C

Dated May 1, 2003

Supercedes all previous drafts of this document

This draft incorporates changes to the MRV & CCS Test Procedures requested by the panel at the November 2002 Sequence IIIF Surveillance Panel Meeting held in San Antonio, Texas. These changes were originally issued as part of Draft 2, issued on December 3, 2002, to the Sequence IIIF Surveillance Panel.

Draft 2A incorporates a version date for tracking purposes and also incorporates mandatory First-In, First-Out parts usage requirements as requested by the Sequence IIIG Test Development Group.

Draft 2B incorporates the refinements to the test presented at the February 19, 2003, Sequence IIIG Surveillance Panel meeting.

Draft 2C incorporates refinements to the test presented at the April 16, 2003, Sequence IIIG Surveillance Panel Meeting.

ASTM Designation: D XXXX -

Standard Test Method for Evaluation of Automotive Engine Oils in the Sequence IIIG, Spark-Ignition Engine¹

This standard is issued under the fixed designation D XXXX; the number immediately following the designation indicates the year of original adoption or, in the case of revision, the year of last revision. A number in parentheses indicates the year of last reapproval. A superscript epsilon ([epsilon]) indicates an editorial change since the last revision or reapproval.

This document is not an ASTM standard; it is under consideration within an ASTM technical committee but has not received all approvals required to become an ASTM standard. It shall not be reproduced or circulated or quoted, in whole or in part, outside of ASTM committee activities except with the approval of the chairman of the committee having jurisdiction and the president of the society. Copyright ASTM, 100 Barr Harbor Drive, West Conshohocken, PA 19428-2959.

The test method described in this standard can be used by any properly equipped laboratory, without the assistance of anyone not associated with that laboratory. However, the ASTM Test Monitoring Center (TMC) provides reference oils and an assessment of the test results obtained on those oils by the laboratory (see Annex xx). By this means, the laboratory will know whether their use of the test method gives results statistically similar to those obtained by other laboratories. Furthermore, various agencies require that a laboratory utilize the TMC services in seeking qualification of oils against specifications. For example, the U.S. Army imposes such a requirement, in connection with several Army engine lubricating oil specifications.

Accordingly, this test method is written for use by laboratories which utilize the TMC services. Laboratories which choose not to use those services may simply ignore those portions of the test method which refer to the TMC.

This test method may be modified by means of Information Letters issued by the TMC. In addition, the TMC may issue supplementary memoranda related to the test method (see Annex A1).

1. Scope (START)

1.1 This test method covers an engine test procedure for evaluating automotive engine oils for certain high-temperature performance characteristics, including oil thickening, varnish deposition, oil consumption, as well as engine wear. Such oils include both single viscosity grade and multiviscosity grade oils which are used in both spark-ignition, gasoline-fueled engines, as well as in diesel engines.

Note 1-Companion test methods used to evaluate engine oil performance for specification requirements are discussed in SAE J304.

1.2 The values stated in SI units are to be regarded as the standard. The values given in parenthesis are provided for information purposes only.

1.3 This standard does not purport to address all of the safety concerns, if any, associated with its use. It is the responsibility of the user of this standard to establish appropriate safety and health practices and determine the applicability of regulatory limitations prior to use.

1.4 This test method is arranged as follows:

Subject	Section
Introduction	
Scope	1
Referenced Documents	2
Terminology	3
Summary of Test Method	4
Significance and Use	5
Apparatus	6
Laboratory	6.1
Drawings	6.2
Specified Equipment	6.3
Test Engine	6.4
Engine Parts	6.4.1
Engine Speed and Load Control	6.5
Engine Cooling System	6.6.1
Flushing Tank	6.7
Coolant Mixing Tank	6.8
Condenser Cooling Systems	6.9
Engine Oil-Cooling System	6.10
Fuel System	6.11
Induction Air Supply Humidity, Temperature, and Pressure	6.12
Temperature Measurement	6.13
Thermocouple Location	6.13.1
Air-to-Fuel Ratio Determination	6.14
Injector Flow Testing	6.14.1

Exhaust and Exhaust Back Pressure Systems	6.15
Blowby Flow Rate Measurement	6.16
Pressure Measurement and Sensor Location	6.17
Reagents and Materials	7
Test Fuel	7.1
Additive Concentrate for the Coolant	7.2
Coolant Preparation	7.3
Pre-Test Cleaning Materials	7.4
Sealing and Anti-seize Compounds	7.5
Test Oil Sample Requirements	9
Preparation of Apparatus	10
Condenser Cleaning	10.1
Intake Manifold Cleaning	10.3
Cleaning of Engine Parts (other than the block and heads)	10.4
Engine Block Cleaning	10.5
Cylinder Head Cleaning	10.6
Engine Build-up Procedure	10.7
General Information	10.7.1
Special Parts	10.7.2
Hardware Information	10.7.3
Sealing Compound Applications	10.7.4
Fastener Torque Specifications and Torquing Procedures	10.7.5
Main Bearing Cap Bolts	10.7.5.1
Cylinder Head Bolts	10.7.5.2
Torques for Miscellaneous Bolts, Studs, and Nuts	10.7.5.3
Parts Replacement	10.8
Engine Block Preparation	10.9
Piston Fitting and Numbering	10.10
Piston Ring Fitting	10.10.1
Pre-Test Camshaft and Lifter Measurements	10.11
Camshaft Bearing Installation	10.12
Camshaft Installation	10.13
Main Bearings	10.14
Crankshaft Installation	10.14.1
Main Bearing Cap Installation	10.14.2
Crankshaft Sprocket	10.15
Camshaft Sprocket and Timing Chain	10.16
Crankshaft End Play	10.17
Piston Pin Installation	10.18
Piston Installation	10.18.1
Harmonic Balancer	10.19
Connecting Rod Bearings	10.20
Engine Front Cover	10.21
Coolant Inlet Adapter	10.22
Oil Dipstick Hole	10.23
Oil Pan	10.24
Cylinder Head Assembly	10.25

Adjustment of Valve Spring Loads	10.26
Cylinder Head Installation	10.27
Hydraulic Valve Lifters	10.28
Pushrods	10.29
Valve Train Loading	10.30
Intake Manifold	10.31
Rocker Covers	10.32
Water Inlet Adapter	10.33
Condenser	10.34
Coolant Outlet Adapter	10.35
Oil Filter Adapter	10.36
Oil Sample Valve	10.37
Ignition System	10.38
Throttle Body	10.39
Accessory Drive Units	10.40
Exhaust Manifolds, Water-Cooled	10.41
Engine Flywheel	10.42
Pressure Checking of Engine Coolant System	10.43
Lifting of Assembled Engines	10.44
Mounting the Engine on the Test Stand	10.45
External Cooling System Cleaning	10.46
Engine Coolant Jacket Cleaning (Flushing)	10.47
Coolant Charging	10.48
Test Oil Charging	10.49
Engine Oil Pump Priming	10.50
Calibration	11
Laboratory and Engine Test Stand Calibration	11.1
Testing of Reference Oils	11.2
Reference Oil Test Frequency	11.3
Reporting of Reference Oil Test Results	11.4
Evaluation of Reference Oil Test Results	11.5
Status of Non-reference Oil Tests Relative to Reference Oil Tests	11.6
Status of Test Stands Used for Non-Standard Tests	11.7
Data Acquisition and Control	11.8
Sample Rate	11.8.1
Measurement Accuracy	11.8.2
Temperature	11.8.3
Pressure	11.8.4
Flow	11.8.5
Speed	11.8.6
Load	11.8.7
Measurement Resolution	11.8.8
System Time Response	11.8.9
Quality Index	11.8.10
Engine Operating Procedure	12
Dipstick and Hole Plug	12.1
Induction Air Inlet Supply Line	12.2
Engine Start-up and Shutdown Procedures	12.3

Start-up	12.4
Shutdown	12.5
Non-Scheduled Shutdowns	12.6
Oil Sampling	12.7
Oil Leveling	12.8
Checks for Glycol Contamination	12.9
Air-to-Fuel-Ratio Measurement and Control	12.10
Blowby Flow Rate Measurement	12.11
NOx Determinations	12.12
Data Recording	12.13
Initial run (Ten Minutes)	12.14
Engine Oil Quality Testing (80 Hours)	12.15
Test Termination	12.16
Determination of Test Results	13
Engine Disassembly	13.2
Preparation of Parts for Rating of Sticking, Deposits, and Plugging	13.3
Piston Deposit Rating	13.4
Post-Test Camshaft and Lifter Wear Measurements	13.5
Used Oil Sample Testing	13.6
Viscosity Test	13.7
Testing Oil Samples for Wear Metals	13.8
Blowby Flow Rate Measurements	13.9
Oil Consumption Computation	13.10
Photographs of Test Parts	13.11
Retention of Representative Test Parts	13.12
Severity Adjustments	13.13
Determination of Operational Validity	13.14
Report	14
Report Forms	14.1
Use of SI Units	14.2
Precision of Reported Units	14.3
Deviations from Test Operational Limits	14.4
Oil Pressure Plot	14.5
Precision and Bias	15
Keywords	16

Annexes

The Role of the ASTM Test Monitoring Center (TMC) and the Calibration Program	A1
Sequence IIIG Test Parts Replacement Guidelines	A2
Sequence IIIG Engine Oil Dipstick Calibration Curve	A3
Sequence IIIG Test Fuel Analysis	A4
Sequence IIIG Test Control Chart Technique for Developing and Applying Severity Adjustments	A5
Sequence IIIG Test Reporting	A6

Sequence IIIG Test Air-to-Fuel Ratio	A7
Sequence IIIG Test Set Points and Control States	A8
Sequence IIIG Quality Index Calculation, Equation Variables	A9
Sequence IIIG Engine Oil Level Worksheet	A10
Blowby Flow Rate Determination	A11
Safety Precautions	A12
Sequence IIIG Blueprint Listing	A13

2. Referenced Documents

2.1 ASTM Standards:

- D 16 Definitions of Terms Relating to Paint, Varnish, Lacquer, and Related Products³
- D 86 Test Method for Distillation of Petroleum Products
- D 130 Test Method for Detection of Copper Corrosion from Petroleum Products by the Copper Strip Tarnish Test
- D 235 Specification for Mineral Spirits (Petroleum Spirits) (Hydrocarbon Dry Cleaning Solvent)
- D 240 Standard Test Method for Heat of Combustion of Liquid Hydrocarbon Fuels by Bomb Calorimeter
- D 323 Test Method for Vapor Pressure of Petroleum Products (Reid Method)
- D 381 Test Method for Existent Gum in Fuels by Jet Evaporation
- D 445 Test Method for Kinematic Viscosity of Transparent and Opaque Liquids (and the Calculation of Dynamic Viscosity)
- D 525 Test Method for Oxidation Stability of Gasoline (Induction Period Method)
- D 1266 Test Method for Sulfur in Petroleum Products (Lamp Method)
- D 1319 Standard Test Method for Hydrocarbon Types in Liquid Petroleum Products by Fluorescent Indicator Adsorption
- D 2422 Classification of Industrial Fluid Lubricants by Viscosity System
- D 2699 Test Method for Knock Characteristics of Motor Fuels by the Research Method
- D 2700 Test Method for Knock Characteristics of Motor and Aviation Fuels by the Motor Method
- D 3231 Standard Test Method for Phosphorus in Gasoline
- D 3237 Test Method for Lead in Gasoline by Atomic Absorption Spectrometry
- D 3338 Standard Test Method for Estimation of Net Heat of Combustion of Aviation Fuels
- D 3343 Standard Test Method for Estimation of Hydrogen Content of Aviation Fuels
- D 4052 Standard Test Method for Density and Relative Density of Liquids by Digital Density Meter
- D 4175 Terminology Relating to Petroleum, Petroleum Products, and Lubricants
- D 4294 Standard Test Method for Sulfur in Petroleum Products by Energy-Dispersive X-Ray Fluorescence Spectroscopy
- D 4485 Specification for Performance of Engine Oils
- D 4684 Standard Test Method for Determination of Yield Stress and Apparent Viscosity of Engine Oils At Low Temperature
- D 4815 Standard Test Method for Determination of MTBE, ETBE, TAME, DIPE, tertiary-Amyl Alcohol and C1 to C4 Alcohols in Gasoline by Gas Chromatography
- D 5119 Test Method for Evaluation of Automotive Engine Oils in the CRC L-38 Spark-Ignition Engine
- D 5191 Standard Test Method for Vapor Pressure of Petroleum Products (Mini Method)

- D 5293 Standard Test Method for Apparent Viscosity of Engine Oils Between -5 and -30°C Using the Cold-Cranking Simulator
- D 5302 Test Method for Evaluation of Automotive Engine Oils for Inhibition of Deposit Formation and Wear in a Spark-Ignition Internal Combustion Engine Fueled with Gasoline and Operated Under Low-Temperature, Light-Duty Conditions
- D 5452 Standard Test Method for Particulate Contamination in Aviation Fuels by Laboratory Filtration
- D 5800 Standard Test Method for Evaporation Loss of Lubricating Oils by the Noack Method
- E 29 Practice for Using Significant Digits in Test Data to Determine Conformance with Specifications
- E 191 Standard Specification for Apparatus For Microdetermination of Carbon and Hydrogen in Organic and Organo-Metallic Compounds
- E 270 Definitions of Terms Relating Liquid Penetrant Examination
- E 344 Terminology Relating to Thermometry and Hydrometry
- E 380 Practice for Use of the International System of Units (SI) (The Modernized Metric System)
- E 608 Specification for Metal-sheathed Base Metal Thermocouples
- E 1119 Standard Specification for Industrial Grade Ethylene Glycol
- G 40 Terminology Relating to Wear and Erosion

2.2 Military Specification:

MIL-L-2104, Lubricating Oil, Internal Combustion Engine, Tactical Service

2.3 SAE Standards:

J183, Engine Oil Performance and Engine Service Classification (Other Than "Energy-Conserving")

J300, Engine Oil Viscosity Classification*HS-23/00*

J304, Engine Oil Tests

2.4 Sequence IIIG-specific Documents:

Sequence IIIG Engine Assembly Manual

ftp://astmtmc.cmu.edu/docs/gas/sequenceiii/procedure_and_ils/IIIG-EAM.pdf

Data Acquisition and Control Automation II Task Force Report, 6/17/97

ftp://astmtmc.cmu.edu/docs/quality_index_and_data_acquisition/DACA_II_Report.pdf

ASTM Test Monitoring Center, System Time Response Measurement Guidelines, 5/27/99

ftp://astmtmc.cmu.edu/docs/quality_index_and_data_acquisition/TMC%20System%20Time%20Response%20Measurement%20Guidelines.pdf

2.5 Other ASTM Documents

Subcommittee B Glossary
<ftp://astmtmc.cmu.edu/docs/Sub.%20B%20glossary.pdf>

3. Terminology

3.1 Definitions:

3.1.1 blowby, n-in internal combustion engines, the combustion products and unburned air-and-fuel mixture that enter the crankcase. Subcommittee B Glossary

3.1.2 BTDC, adj-abbreviation for Before Top Dead Center; used with the degree symbol to indicate the angular position of the crankshaft relative to its position at the point of uppermost travel of the piston in the cylinder.

3.1.3 calibrate, v-to determine the indication or output of a measuring device with respect to that of a standard. E 344

3.1.4 clogging, n-the restriction of a flow path due to the accumulation of material along the flow path boundaries.

3.1.5 cold-stuck piston ring, n-in internal combustion engines, a piston ring that is stuck when the piston and ring are at room temperature, but inspection shows that it was free during engine operation. Subcommittee B Glossary

3.1.6 correction factor, n-a mathematical adjustment to a test result to compensate for industry-wide shifts in severity.

3.1.7 corrosion, n-the chemical or electrochemical oxidation of the surface of metal which can result in loss of material or accumulation of deposits. E 270

3.1.8 debris, n-in internal combustion engines, solid contaminant materials unintentionally introduced into the engine or resulting from wear.

3.1.9 engine oil, n-a liquid that reduces friction or wear, or both, between the moving parts within an engine, and also serves as a coolant. D 4485

3.1.10 EWMA, n-exponentially-weighted moving average.

3.1.11 free piston ring, n-in internal combustion engines, a piston ring that will fall in its groove under the force of its own weight when the piston is moved from a vertical (axis orientation) to a horizontal position.
-In determining this condition, the ring may be touched slightly to overcome static friction.

3.1.12 hot-stuck piston ring, n-in internal combustion engines, a piston ring that is stuck when the piston and ring are at room

temperature, and inspection shows that it was stuck during engine operation.

Subcommittee B Glossary

3.1.13 Lubricant Test Monitoring System, LTMS, n-an analytical system in which ASTM calibration test data are used to manage lubricant test precision and severity (bias).

3.1.14 LTMS date, n-the date the test was completed unless a different date is assigned by the TMC.

3.1.15 LTMS time, n-the time the test was completed unless a different time is assigned by the TMC.

3.1.16 lubricant, n-any material interposed between two surfaces that reduces the friction or wear, or both, between them.

3.1.17 noncompounded engine oil, n-a lubricating oil having a viscosity within the range of viscosities of oils normally used in engines, and that may contain anti-foam agents or pour depressants, or both, but not other additives. D 5119

3.1.18 non-reference oil, n-any oil other than a reference oil; such as a research formulation, commercial oil, or candidate oil.

Subcommittee B Glossary

3.1.19 oxidation, n-of engine oil, the deterioration of the oil which is observed as increased viscosity, sludge formation, varnish formation, or a combination thereof, as a result of chemical and mechanical action. D 5119

3.1.20 quality index, n-a mathematical formula that uses data from controlled parameters to calculate a value indicative of control performance.

3.1.21 reference oil, n-an oil of known performance characteristics, used as a basis for comparison.

Subcommittee B Glossary

DISCUSSION-Reference oils are used to calibrate testing facilities, to compare the performance of other oils, or to evaluate other materials (such as seals) that interact with oils.

3.1.22 reference oil test, n-a standard Sequence IIIG engine oil test of a reference oil designated by the ASTM TMC.

3.1.23 rust (coatings), n-the reddish material, primarily hydrated iron oxide, formed on iron or its alloys resulting from exposure to humid atmosphere or chemical attack. D 16

3.1.24 SA, n-severity adjustment.

3.1.25 scoring, n-in tribology, a severe form of wear characterized by the formation of extensive grooves and scratches in the direction of sliding. G 40

3.1.26 scuffing, n-in lubrication, surface damage resulting from localized welding at the interface of rubbing surfaces with subsequent fracture in the proximity of the weld area. D 4175

3.1.27 used oil, n-any oil that has been in a piece of equipment (for example, an engine, gearbox, transformer, or turbine), whether operated or not. D 4175

3.1.28 varnish, n-in internal combustion engines, a hard, dry, generally lustrous, deposit which can be removed by solvents but not by wiping with a cloth;

3.1.29 wear, n-the loss of material from, or relocation of material on, a surface. D 5302

DISCUSSION-Wear generally occurs between two surfaces moving relative to each other, and is the result of mechanical or chemical action, or of a combination of mechanical and chemical actions.

3.2 Descriptions of Terms Specific to This Standard:

3.2.1 build-up oil, n-EF-411 noncompounded ISO VG 32 (SAE 10) oil used in lubricating some of the Sequence IIIG parts during engine assembly.

3.2.2 calibrated test stand, n-a test stand on which Sequence IIIG engine oil tests are conducted within the lubricant test monitoring system as administered by the ASTM TMC (see 11.1).

3.2.3 Central Parts Distributor (CPD), n-the manufacturer and supplier of many of the parts and fixtures used in this test method.

DISCUSSION-Because of the need for rigorous inspection and control of many of the parts used in this test method, and because of the need for careful manufacture of special parts and fixtures used, companies having the capabilities to provide the needed services have been selected as the official suppliers for the Sequence IIIG test method. These companies work closely with the original parts suppliers, with the Test Developer, and with the ASTM groups associated with the test method to help ensure that the equipment and materials used in the method function satisfactorily.

3.2.4 Special Test Parts (STP), n-parts that do not meet all the definitions of critical parts, non-production parts, or SPO parts, but must be obtained from the specified distributor.

3.2.5 critical parts (CP), n-those components used in the test, which are known to affect test severity.

-They must be obtained from the Central Parts Distributor or Special Parts Supplier, who will identify them with either a serial number or a batch lot control number.

3.2.6 EOT time, n-end of test time, the end of test time will be twenty (20) minutes after the engine reaches 100 test hours of operation. This allows for the 90-second ramp down, the 15 minute wait for the oil to drain into the sump, and allows an operator 3.5 minutes to take the oil level.

3.2.7 non-production parts (NP), n-these are components used in the test, which are available only through the Central Parts Distributor, Special Parts Supplier, or the Test Developer.

3.2.8 participating laboratory, n-a laboratory equipped to conduct Sequence IIIG tests, which conducts reference oil tests in cooperation with the ASTM TMC, in order to have calibrated test stands available for candidate oil testing.

3.2.9 pinched piston ring, n-a ring which will not move in its groove under moderate finger pressure, but which has a polished face over its entire circumference indicating that it was free during engine operation. The ring may be restricted over varying degrees of its circumference.

3.2.10 Service Parts Operations parts (SPO), n-these test components are obtained from Service Parts Operations a division of General Motors Corporation.

3.2.11 sluggish piston ring, n-one that is not free; it offers resistance to movement in its groove, but it can be pressed into or out of the groove under moderate finger pressure; when so moved, it does not spring back.

3.2.12 Special Parts Supplier, (SPS) n-the manufacturer and supplier of many of the parts and fixtures used in this test method.

3.2.13 Special Test Parts , n-parts that do not meet all the definitions of critical parts, non-production parts, or SPO parts, but must be obtained from the Special Parts Supplier.

3.2.14 standard test, n-an operationally-valid, full-length Sequence IIIG test conducted on a calibrated test stand in accordance with the conditions listed in this standard.

DISCUSSION-Such a test is also termed a *valid test*.

3.2.15 stuck piston ring, n-one that is either partially or completely bound in its groove; it cannot be readily moved with moderate finger pressure.

3.2.16 Test Developer, n-the group or agency which developed the Sequence IIIG test method before its standardization by ASTM, and which continues to be involved with the test in respect to modifications in the test method, development of Information Letters, supply of test parts, etc.

DISCUSSION-As defined in Committee D02.B0.08 Regulations Governing the American Society for Testing and Materials Test Monitoring System, "Test Developer" shall refer to those individual companies which have developed and/or are responsible for supplying the basic hardware for the tests referred to in Paragraph 2.1 (Article 2-Purpose of the Test Monitoring System)." In the case of the Sequence IIIG test, the Test Developer is General Motors Powertrain Materials Engineering.

3.2.17 test full mark, n-the oil level established after the ten (10) minute initial run-in.

3.2.18 test oil, n-an oil subjected to a Sequence IIIG engine oil test.

DISCUSSION-It can be any oil selected by the laboratory conducting the test. It could be an experimental product or a commercially-available oil. Often, it is an oil which is a candidate for approval against engine oil specifications (such as manufacturers' or military specifications, etc.).

3.2.19 test stand, n-a suitable foundation (such as a bedplate) to which is mounted a dynamometer, and which is equipped with a suitable data acquisition system, fluids process control system, supplies of electricity, compressed air, etc., to provide a means for mounting and operating an engine in order to conduct a Sequence IIIG engine oil test.

3.2.20 test start, n-introduction of test oil into the engine after the final assembly and mounting in the test stand.

3.2.21 test start time, n-the time that test oil was introduced into the engine on the test stand.

4. Summary of Test Method

4.1 A 3800 Series II 3.8L (231-in.³) V-6 test engine block is solvent-cleaned, measured, and rebuilt; using new parts installed as specified in this test method.

4.2 The engine is installed on a test stand equipped with an appropriate data acquisition system, the required fluids process control system and all necessary accessories for controlling speed, load, and various other operating parameters.

4.3 The engine is charged with the test oil.

4.4 The engine is operated for a 10 min initial run-in period to check all test stand operating systems and to establish a zero hour oil level reading and initial oil viscosity sample.

4.5 Following the 10 min initial run-in and oil level, the engine is operated under non-cyclic, moderately high speed, load, and temperature conditions for 100-h, in 20-h segments.

4.6 The initial oil level in the oil pan is determined after the 10-min initial run-in, and subsequent oil level calculations are determined during the oil leveling period at the end of each 20-h segment.

4.7 Used oil samples are taken after the 10-min initial run-in and after each 20-h test segment; kinematic viscosity at 40°C (104°F) is determined for each of the ~~ten~~ six samples; the percentage change in viscosity of the ~~nine~~ five latter samples is determined relative to the viscosity of the first used oil sample (10-min initial run-in).

4.8 At the conclusion of the test, the engine is disassembled and the parts are visually rated to determine the extent of deposits formed. In addition, wear measurements are obtained.

5. Significance and Use

5.1 This test method was developed to evaluate automotive engine oils for protection against oil thickening and engine wear during moderately high-speed, high-temperature service.

5.2 The increase in oil viscosity obtained in this test indicates the tendency of an oil to thicken because of oxidation. In automotive service, such thickening can cause oil pump starvation and resultant catastrophic engine failures.

5.3 The deposit ratings for an oil indicate the tendency for the formation of deposits throughout the engine, including those which can cause sticking of the piston rings in their grooves. This can be involved in the loss of compression pressures in the engine.

5.4 The camshaft and lifter wear values obtained in this test provide a measure of the anti-wear quality of an oil under conditions of high unit pressure mechanical contact.

5.5 The test method was developed to correlate with oils of known good and poor protection against oil thickening and engine wear. Specially formulated oils that produce less than desirable results with unleaded fuels were also used during the development of this test.

5.6 The Sequence IIIG engine oil test has replaced the Sequence IIIF test and is used in specifications and classifications of engine lubricating oils, such as the following:

5.6.1 Specification D 4485,

5.6.2 Military Specification MIL-L-2104, and

5.6.3 SAE Classification J183.

6. Apparatus

6.1 Laboratory-Observe the following laboratory conditions to ensure good control of test operations, and good repeatability:

6.1.1 Maintain the ambient laboratory atmosphere relatively free of dirt, dust, and other contaminants.

6.1.2 Control the temperature of the room in which parts measurements are made so that the temperature for after-test measurements is within a range of $\pm 3^{\circ}\text{C}$ ($\pm 5^{\circ}\text{F}$) relative to the temperature for the before-test measurements. If difficulties with parts fits are encountered, consider the effects of temperature coefficient of expansion. See 6.2.

6.1.3 Filter the air in the engine build-up area, and control its temperature and humidity to prevent accumulation of dirt or rust on engine parts.

6.1.4 If an engine is assembled in an area of controlled environment and moved to a non-controlled area, provide suitable protection of the engine so that moist air cannot enter the engine and promote rusting before the test.

6.1.5 Do not permit air from fans or ventilation systems to blow directly on an engine mounted on a test stand during test operation.

6.2 Drawings-Obtain the equipment drawings referenced in Annex A3 of this test method from the ASTM TMC. Because the drawings may not be to scale, or may not contain dimensions, when using them to fabricate special parts, do not use a dimensionless drawing as a pattern. Drawings supplied with dimensions are considered to be correct when the temperature of the equipment is $22^{\circ}\text{C} \pm 3^{\circ}\text{C}$ ($72^{\circ}\text{F} \pm 5^{\circ}\text{F}$), unless otherwise specified.

6.3 Specified Equipment-Use the equipment specified in the procedure whenever possible. Substitution of equivalent equipment is allowed, but only after equivalency has been proven to the satisfaction of the ASTM TMC, the Test Developer, and the ASTM Sequence IIIG Surveillance Panel.

6.3.1 Do not use heat lamps or fans directed at the engine, and do not use insulation on the engine, for oil or coolant temperature control.

DISCUSSION-For operator safety and the protection of test components, the use of shielding and insulation on the exhaust system may be incorporated downstream of the oxygen sensor elbow.

6.4 Test Engine-The test engine is based on a 1996-97 L36 3800 Series II 3.8L (231-in.³) V-6 engine with approximately a 9.0:1 compression ratio, equipped with a production fuel injection system, a retrofit flat tappet valvetrain, and a special Powertrain Control Module (PCM) for test specific dynamometer operation. Rebuild the engine as specified in this test method.

6.4.1 Engine Parts-Use the engine parts specified in the Sequence IIIG Engine Assembly Manual.

6.4.1.1 Use all engine parts as received from the supplier, Central Parts Distributor, Special Parts Supplier, or original equipment manufacturer, unless modifications are specified in this test method or the Sequence IIIG Engine Assembly Manual.

6.4.1.2 Any parts obtained for use in Sequence IIIG testing shall not be diverted to other applications.

6.4.1.3 Sequence IIIG engine parts shall be rendered useless for automotive engine applications before disposal.

6.4.1.4 All non-reusable engine test components shall be used on a first-in, first-out basis as received from the supplier, Central Parts Distributor, Special Parts Supplier, or original equipment manufacturer, i.e. no hardware selection is permitted.

6.5 Engine Speed and Load Control-Use dynamometer speed and load control systems which are capable of controlling the speed and load as specified in Section 11 of this procedure under Data Acquisition and Control.

6.6 Sequence IIIG Fluid Conditioning Module -Use the Kundinger Fluid Conditioning Module (or an equivalent in-house manufactured fluid conditioning module) to control the following parameters: engine coolant, condenser coolant, oil cooler coolant, exhaust manifold coolant, and the test fuel supply. The system incorporates the following features: pumps, flow meters, flow control and three-way control valves, external heating and cooling systems, pressure regulator and low-point drains. The system integrates with the test stand data acquisition and control computer for process control.

6.6.1 Engine Cooling System-Contained in the Fluid Conditioning Module, supplies non-pressurized coolant at a flow rate of 160 L/min (42.3 gal/min) temperature controlled at ~~122°C (251.6°F)~~ 115°C (239°F) at the engine coolant outlet. The system incorporates the following features: pump, vortex-type flow meter, flow control and three-way control valves, external heating and cooling systems, and low-point drains. The system integrates with the test stand data acquisition and control computer for process

control and maintains the specified engine coolant temperature and flow. The system should be flushed with Sequence IIIF Test Component Cleaner at least once each reference period.

6.7 Flushing Tank-Use a flushing tank such as that shown in drawings RX-116924-C, RX-117230-E, and RX-117231-C to circulate the cleaning agents. Use plumbing materials that are impervious to the acidic cleaning agents (stainless steel has been found satisfactory).

6.8 Coolant Mixing Tank-Use a mixing tank such as that shown in drawing RX-117350-D to premix the engine coolant.

6.9 Condenser Cooling System- Contained in the Fluid Conditioning Module, supplies non-pressurized coolant at a flow rate of 10 L/min \pm 2 L/min (2.64 gal/min \pm 0.53 gal/min) and temperature controlled at 40°C (104°F) (see A9) at the condenser outlet. The system incorporates the following features: condenser heat exchanger, BX-212-1 or OHT3F-075-1¹⁶: condenser adapter fitting, pump, magnetic-type flow meter, flow control and three-way control valves, external heating and cooling systems, and low-point drains. The system integrates with the test stand data acquisition and control computer for process control and maintains the specified coolant temperature and flow.

6.10 Engine Oil-Cooling System- The system consists of an Oil Filter Adapter with ~~a~~ an external Bypass Port, an Oil Filter Adapter Fitting, an Oil Filter Block with the bypass valve blocked, a Bypass Valve Assembly Housing, an Oil Cooler with the bypass valve welded shut, and gaskets specified in the Sequence IIIG Engine Assembly Manual (section 8 sheet 3). The system uses engine coolant provided through the Fluid Conditioning Module at a flow rate of approximately 12.0 L/min (3.17 gal/min through a three-way valve as necessary to control the engine oil temperature. ~~When testing high oxidation sensitive oils, the oil cooling system may go into a by-pass mode, causing the oil cooler to be by-passed. In this condition the TMC may allow engineering judgement for the oil temperature Quality Index on reference oil tests.~~

6.10.1 Replace the oil cooler after every test.

6.10.2 Do not use cuprous lines or fittings in the oil system.

6.10.3 Do not use magnetic plugs in the oil system.

6.10.4 Use suitable hose and fittings when plumbing the oil-cooling system.

6.11 Fuel System- Contained in the Fluid Conditioning Module, a pressurized, recirculating fuel system, including a pressure regulator to provide $365 \text{ kPa} \pm 6.9 \text{ kPa}$ ($52.94 \pm 1 \text{ psi}$) fuel pressure. The system should be switched off so no fuel pressure is present at the injector rail during engine shutdowns.

6.12 Induction Air Supply Humidity, Temperature, and Pressure-Maintain the throttle body intake air at a moisture content of $11.4 \pm 0.7 \text{ g/kg}$ ($80.0 \pm 5 \text{ grains/lb.}$) of dry air, a dry bulb temperature of $35^\circ\text{C} \pm 2^\circ\text{C}$ ($95^\circ\text{F} \pm 3.6^\circ\text{F}$), and a static pressure of 0.050 kPa (0.2 in. of water) (see A9). Temperature and pressure shall be measured at the inlet air adapter.

6.13 Temperature Measurement-Use 1/8 in iron-constantan (Type J) thermocouples for temperature measurement. The thermocouples used shall be as short as possible to meet the insertion depth requirements listed in this test method and minimize exposed thermocouple sheathing.

6.13.1 Thermocouple Location-Locate the sensing tip of all thermocouples in the center of the stream of the medium involved, unless otherwise specified.

6.13.1.1 Oil Filter Adapter-Install the thermocouple in the tapped hole in the oil filter adapter as shown in the Sequence IIIG Engine Assembly Manual, section 8 sheet 3.

6.13.1.2 Oil Pan (Sump)-Install the thermocouple in the oil sump drain plug OHT3F-063-1 with the tip extending 19 to 25 mm (0.75 to 1.0 in.) beyond the end of the sump drain plug.

6.13.1.3 Engine Coolant In-Install the thermocouple in the coolant inlet adapter OHT3F-031-1 with the sensing tip centered in the coolant flow.

6.13.1.4 Engine Coolant Out-Install the thermocouple for the coolant outlet OHT3F-034-1 with the sensing tip centered in the coolant flow.

6.13.1.5 Condenser Coolant Out-Locate the thermocouple in the coolant-out fitting in the condenser with the sensing tip centered in the coolant flow.

6.13.1.6 Blowby Gas-Install the thermocouple at the outlet of the condenser with the sensing tip centered in the blowby gas flow.

6.13.1.7 Fuel-Install the thermocouple in the fuel rail fittings on the inlet side of the fuel rail.

6.13.1.8 Inlet Air-Install the thermocouple in the inlet air adapter as shown in the Sequence IIIG Engine Assembly Manual section 8 sheet 4.

6.13.1.9 External Oil Bypass Thermocouple-Install an appropriate thermocouple in the Bypass Valve Assembly Housing, part number OHT3F-084-1, with the sensing tip centered in the oil stream.

6.14 Air-to-Fuel Ratio Determination-Determine the engine air-to-fuel ratio by measuring the CO, CO₂, and O₂ components of the exhaust gas sample with electronic exhaust gas analysis equipment. When using electronic exhaust gas analyzers, take particular care to ensure that the exhaust gas sample is dried prior to introducing it to the analyzer. Take the exhaust gas samples from the exhaust manifold exit flanges. See A7. (See Sequence IIIG Engine Assembly Manual section 8 sheet 1.)

6.14.1 Injector Flow Testing-Flow test the fuel injectors before each test according to the following procedure:

6.14.1.1 ~~Aliphatic naphtha~~ mineral spirits should be used as the calibration fluid.

6.14.1.2 Apply 40 psi to the fuel rail.

6.14.1.3 Apply 13 volts to the injector solenoid continuously.

6.14.1.4 Allow the injector to spray into a graduated cylinder that is capable of holding at least 250 ml.

6.14.1.5 All injectors should be volume checked for 60 seconds. Note the volume that each injector produces.

6.14.1.6 Observe the spray pattern that each injector produces. If the injector has a straight stream or dribbles, it should be discarded.

6.14.1.7 When installing the injectors on the fuel rail it is important that the six injectors that are installed on an engine produce volumes that are within 5 ml of each other.

6.14.2 Remove the solvent that is remaining in the injector from the flow check using compressed air.

6.15 Exhaust and Exhaust Back Pressure Systems:

6.15.1 Exhaust Manifolds and Pipes-Install water-cooled exhaust manifolds and stainless runners as shown in the Sequence IIIG Engine Assembly Manual section 8 sheet 2.

6.15.2 Water-Jacketed Exhaust Pipes- For safety reasons, water-jacketed exhaust pipes or external water spray systems are allowed only when introduced beyond the "Y" pipe and after the system drops below the bedplate or enters the overhead loft.

6.15.3 Exhaust Sample Lines-Install exhaust sample lines in the two exhaust manifold exit flanges. Both left and right banks should use the same sample line location (inboard or outboard), as shown in the Sequence IIIG Engine Assembly Manual section 8 sheet 1. Use good laboratory practice to ensure that water does not accumulate in the lines during engine operation.

6.15.4 Back-Pressure Lines- Install exhaust back pressure lines in the two exhaust manifold exit flanges. Both left and right banks should use the same backpressure measurement location (inboard or outboard), as shown in the Sequence IIIG Engine Assembly Manual section 8 sheet 1. Use good laboratory practice to ensure that water does not accumulate in the lines during engine operation.

6.16 Blowby Flow Rate Measurement-Use the sharp-edge orifice meter, part number RX-116169-A1, revision N, to measure engine blowby flow rates. See 12.11.

6.17 Pressure Measurement and Pressure Sensor Location-Use electronic pressure transducers located as indicated in this test method.

6.17.1 Intake Manifold Vacuum-Use a transducer having a range of 0 to 100 kPa (0 to 20 in. Hg). Connect the transducer to the vacuum outlet located on the intake plenum main vacuum port. Tee the transducer, manifold absolute pressure sensor and fuel rail pressure regulator all together from the main port.

6.17.2 Engine Oil Gallery Pressure- Use a transducer having a range of 0 to 700 kPa (0 to 100 psi). Connect the transducer to the location shown in the Sequence IIIG Engine Assembly Manual section 8 sheet 3 (Port labeled "Oil Filter Pressure").

6.17.3 Oil Pump Outlet Pressure- Use a transducer having a range of 0 to 700 kPa (0 to 100 psi). Connect the transducer to the location shown in the Sequence IIIG Engine Assembly Manual section 8 sheet 3 (Port labeled "Oil Pump Pressure").

6.17.4 Exhaust Back Pressure- Use a transducer having a range of 0 to 10 kPa (0 to 40 in. of water) attach the line to the exhaust

end plate as shown in the Sequence IIIG Engine Assembly Manual section 8 sheet 1.

6.17.5 Inlet Air Pressure- Use a transducer having a range of 125 Pa (0.5 in. of water). Connect the transducer to the air inlet adapter as shown in the Sequence IIIG Engine Assembly Manual section 8 sheet 4.

6.17.6 Crankcase Pressure- Use a transducer having a range of -125 to +125 Pa (-0.5 to +0.5 in. of water). Connect the transducer to the front of the lower intake manifold as shown in the Sequence IIIG Engine Assembly Manual section 6 sheet 7.

6.18 PCV Plug- The positive crankcase ventilation system is blocked off during testing using a dummy PCV valve, part number OHT3F-002-1, as shown in the Sequence IIIG Engine Assembly Manual section 6 sheet 11.

6.19 Parts Modifications- Modify the following parts according to the instructions listed in the Sequence IIIG Engine Assembly Manual:

6.19.1 Throttle body, section 7 sheet 5.

6.19.2 Intake manifold, section 6 sheet 7.

6.19.3 Engine block, section 1 sheet 2.

7. Reagents and Materials

7.1 Test Fuel-Use only EEE unleaded fuel ^{xx} (Warning-see Note 4) (see A4, Table A4.1), observing the following:

Note-4: Warning-Flammable. Health Hazard.

7.1.1 Make certain that all tanks used for transportation and storage are clean before they are filled with test fuel.

7.1.2 Verify that at least 3000 L (800 gal) of test fuel (Warning-see Note 5) is available for use before initiating a test.

Note-5: Warning-Flammable. Health Hazard.

7.2 Engine and Condenser Coolant Use ethylene glycol meeting ASTM Standard Specification E1119-92 for Industrial Grade Ethylene Glycol^{xx} (Warning--see Note 6).

^{xx} Ethylene Glycol meeting this specification is available from Dow Chemical Co., 2040 Dow Center, Midland, MI 48674. An equivalent may be used.

7.3 Coolant Additive Use ~~Naccool 2000 or~~ Pencoool 2000 coolant additive^{xx} for the engine and condenser coolant.

Note-6: Warning-Combustible. Health Hazard.

Note-7: Warning-See the appropriate materials safety data sheet.

7.4 Coolant Preparation-Prepare the coolant blend for the engine coolant system, and for the oil cooler and condenser coolant system, in the following manner:

7.4.1 Do not apply heat either during, or following, the coolant preparation.

7.4.2 Use a container of a size adequate to hold the entire coolant blend required by both systems. See drawing RX-117350-D for an example of a suitable container.

7.4.3 Add the required amount of glycol (Warning-see Note 8) to the container.

Note-8: Warning-Combustible. Health Hazard.

7.4.4 Add the required amount of additive concentrate to the container to achieve a concentration of 15.625 mL/L (0.125 pt/gal) of coolant additive to glycol. (Warning-see Note 7).

7.4.5 Mix the blend in the container for 30 min.

7.4.6 Add the blend to the engine coolant system and the condenser coolant system.

7.5 Pre-Test Cleaning Materials-Use the cleaning materials (see Note 9) specified in the following list for cleaning of parts to be used in the test. Use no substitutes (see Note 10).

7.5.1 Penmul L460 shall be used as the parts cleaning agent^{xx} (Warning-see Note 11).

^{xx} Penmul L460 available from the Penetone Corporation 74 Hudson Ave. Tenafly, New Jersey 07670.

7.5.2 ~~Aliphatic naphtha~~-Mineral Spirits meeting ASTM Specification D 235 Type II Class A specifications. ~~Type I regular mineral spirits (Stoddard solvent) requirements, with a boiling point of 149-204°C (300-400°F)~~^{xxx}-(see Note 9, 12, & 13).

7.5.3 Sequence IIIF Test Component Cleaner,^{xx} a mixture (by mass) of:

94 parts oxalic acid^{xx1} (Warning-see Note 14).

6 parts dispersant^{xx2} (Warning-see Note 14).

^{xx1} Oxalic acid (55-lb bags) and sodium carbonate (50-lb bags) are available from Ashland Chemical Co., P.O. Box 391, Ashland, KY. 41114. If permitted by the hazardous materials disposal practices in a laboratory, sodium carbonate can be used to neutralize the oxalic acid in used Sequence IIIF Test Component Cleaner.

^{xx2} Petro Dispersant Number 425 Powder (50-lb bags) is available from Witco Corp., 3230 Brookfield, Huston, TX. 77045.

Note-9: Warning-See the appropriate materials safety data sheet.

Note 10-Only these specific materials and sources have been found satisfactory. If chemicals other than these are proposed for use, equivalency must be proven and approval obtained from the ASTM TMC.

Note 11: Warning-Corrosive. Health Hazard.

Note 12: Warning-Flammable. Health Hazard.

Note 13: Warning-Combustible. Health Hazard.

Note 14: Warning-Corrosive. Health Hazard.

7.5.4 NAT-50 or PDN-50 soap shall be used in automatic parts washers to clean Sequence IIIG Engine parts.^{xx} See 10.4.

7.6 Sealing and Anti-seize Compounds-Use the sealing compounds specified in the following list. See Notes 16 and 17.

7.6.1 Permatex Number 2 non-hardening sealer shall be used as the sealing compound for the cylinder head bolts,^{xx3}

^{xx3} Permatex Number 2 non-hardening sealer is available through local distributors of Permatex products.

7.6.2 Perfect Seal Number 4 Brush-Type Sealing Compound shall be used as the sealing compound for front and rear cover gaskets. ^{xx4}

^{xx4} Perfect Seal Number 4 Brush-Type Sealing Compound, part GM3D (16oz container), must be used. It can be ordered from P.O.B. Sealants Inc., 11102 Kenwood Rd. Cincinnati, OH. 45242

7.6.3 GM Black RTV sealer^{yy}, part number 12346193, is allowable for use on the oil pan gasket and intake manifold gasket only. See Sequence IIIG Engine Assembly Manual section 4 sheet 13 and section 6 sheet 6.

^{yy} GM Black RTV Sealer is available from local GM dealers.

{Section 8 deleted.}

9. Test Oil Sample Requirements

9.1 Selection-The supplier of the test oil sample shall determine that it is representative of the lubricant formulation being evaluated and that it is not contaminated.

9.2 Quantity-The supplier should provide 15 L (4 gal) of the test oil sample.

Note-18 A Sequence IIIG Test can be conducted with only 12 L (3.17 gal) of test oil, provided that no spillage or leakage occurs during test preparation. The greater quantity is specified to accommodate such spillage and leakage.

9.3 Storage Prior to Test-The test laboratory shall store the test oil sample in a covered building to prevent contamination by rainwater.

10. Preparation of Apparatus

10.1 Condenser Cleaning-Immediately after completing a Sequence IIIG test, remove the stainless steel condenser assembly, disassemble it, and soak it in parts cleaning agent. (Warning-see Note 19) After the soaking, clean the inside of the tube with parts cleaning agent (Warning-see Note 20) and a non-cuprous bristle brush.⁵⁷ ~~Thoroughly clean~~ ~~Rinse~~ both the blowby gas and coolant sides of the condenser with clean ~~aliphatic-naphtha~~ ~~mineral spirits~~. (Warning-see Note 21)

Note-19: Warning-Corrosive. Health Hazard.

Note 20: Warning-**Blank**

Note 21: Warning-Combustible. Health Hazard.

10.1.1 After ten tests, or more frequently if film is present, clean the coolant side of the condenser by flushing it for ½ hour with a water solution of 20 g/L of Sequence IIIF Test Component Cleaner (Warning-see Note 22) (see 7.4). Rinse it thoroughly with tap water at 60°C (140°F).

Note-22: Warning-Corrosive. Health Hazard.

10.1.2 After cleaning the coolant side of the condenser, pressure check it with air at 70 kPa (10 psi) (Warning-see Note 23).

Note-23: Warning-For technical use only.

10.3 Intake Manifold Cleaning-Clean the intake manifold with ~~aliphatic-naphtha~~ ~~mineral spirits~~.

Note 25: Warning-Combustible. Health Hazard.

10.4 Cleaning of Engine Parts (other than the block and heads)-Clean all engine parts (other than the block and heads; see 10.5 and 10.6) thoroughly prior to engine assembly. Degrease them first, and then brush them with parts cleaning agent. (Warning-see Note 26) Immediately remove the cleaner by spraying with hot tap water ~~followed by spraying with~~ ~~mineral spirits~~. (Warning-see Note 27) Blow dry the parts with clean, dry shop air (Warning-see Note 28), and immediately coat them with a 50/50 mixture of EF-411 build-up oil and ~~aliphatic-naphtha~~ ~~mineral spirits~~.^{xx}

Note-26: Warning-Corrosive. Health Hazard.

Note 27: Warning-Combustible. Health Hazard.

Note 28: Warning-For technical use only.

10.5 Engine Block Cleaning-Clean the block according to the following:

10.5.1 Remove the debris in the head bolt and main bearing cap bolt holes using class 2B bottoming taps of the appropriate sizes.

10.5.2 Physically remove all sand and slag deposits, and any other debris, from the water jacket using a sharp-ended drill rod or a long straight slot screwdriver.

10.5.2.1 Check the camshaft tunnel for sharp edges on the front of each bore and along the cross-drilled oil gallery inside each bearing bore. Deburr as necessary. See the Sequence IIIG Engine Assembly Manual section 1 sheet 2.

10.5.3 Thoroughly clean the block prior to honing as follows: In the case of a block used in a previous test, remove the crankshaft, main bearings, and bearing caps. In addition, all bushings, bearings, and oil gallery plugs shall be removed prior to cleaning. With either a new or used block, prevent cleaner or oil from entering the engine coolant passages. See Sequence IIIG Engine Assembly Manual, section 1 sheet 5.

10.5.3.1 The block should be cleaned in a heated bath or temperature controlled automated parts washer before and after honing. Follow the suggested guidelines as listed below to ensure there is no oxidation flash over of the engine block after this process.

- 1) Use only NAT-50 or PDN-50 soap at a concentration of 16 pounds of soap per 100 gallons of water.
- 2) Set the temperature of the water to 140 degrees F.
- 3) Do not pre-condition the water that is being used in any way.
- 4) Prior to installing the engine in the parts washer, ensure that all coolant passages are blocked off to prevent cleaning solutions from entering the passages.
- 5) Allow the block to run through the cleaning cycle for a period of 30 to 40 minutes.
- 6) After the cycle is complete, immediately remove the block from the washer and **thoroughly clean (removing all residues from the automated parts washer soap) the crankcase reciprocating, lifter valley, cylinders, oil galleries, and external sections of the engine ~~spray it down~~ with ~~aliphatic naphtha~~ mineral spirits.**
- 7) Wipe cylinder bores out with a lint free towel.

8) Spray engine block with a mixture of 50/50 EF-411 build-up oil and ~~aliphatic naphtha~~ mineral spirits.

10.5.3.2 See the Sequence IIIG Engine Assembly Manual section 2 for the honing procedure.

10.5.3.3 After the cylinder walls have been honed, clean the engine block again according to 10.5.3 and spray the engine block (including all oil galleries) first with ~~aliphatic naphtha~~ mineral spirits (Warning-see Note 32) followed by a 50:50 mixture of ~~aliphatic naphtha~~ mineral spirits and EF-411 build-up oil. Using this 50:50 mixture, wipe out the cylinder bores with clean cloth towels until all honing residue has been removed.

Note-32: Warning-Combustible. Health Hazard.

10.5.3.4 Air dry the engine block, using clean dry shop air (Warning-see Note 33), and coat the cylinder walls with EF-411 build-up oil using soft, lint-free, clean cloths.

Note-33: Warning-For technical use only.

10.6 Cylinder Head Cleaning-Clean the cylinder heads according to the following:

10.6.1 Using a flexible probe, explore all accessible water passages to detect any material that would interfere with coolant flow.

10.6.2 Using a 10-mm wire brush, extending two-thirds the length of the cylinder head from freeze plug hole to freeze plug hole, clean all core sand and casting slag from the cylinder heads to ensure unrestrained coolant flow.

10.6.3 Clean the cylinder heads according to the recommended engine block cleaning procedure (See 10.5.3.1).

10.7 Engine Build-up Procedure-Laboratories should design and maintain engine build data sheets in a format compatible with Microsoft® Excel® and record data for cylinder bore measurements, piston and ring sizing data, valvetrain spring load calibrations, camshaft and lifter measurements, and all critical part identification information. This data shall be made available to the TMC and the Test Developer for investigative studies as deemed necessary for hardware investigations during times of industry severity shifts or other problems.

10.7.1 General Information-Use only the listed service parts, special test parts, and special build-up procedures specific to this test as outlined in this test method and the Sequence IIIG

Engine Assembly Manual. See 6.4. Make and record measurements specified in this test method of the cylinders, pistons, rings, valve train, cam, and lifters. These measurements will provide evidence of conformance to the specifications of the method, and will provide baselines for determining engine wear which occurs during a Sequence IIIG test.

10.7.2 Special Parts-Use the special parts listed in the Sequence IIIG Engine Assembly Manual sections 8, 9, 10, and 11.

10.7.3 Hardware Information-Complete Form 12, Hardware Information, in standardized report form set (See A6).

10.7.5 Fastener Torque Specifications and Torquing Procedures-Use the following specifications and torquing procedures when installing bolts in the engine:

10.7.5.1 Main Bearing Cap Bolts- Do not use air tools on bolts to seat the main bearing caps in the engine block. Use a rubber or plastic mallet to seat the main bearing caps to avoid misalignment and potential damage to the engine block. Apply build-up oil to the threads and to the surfaces of the bolts that contact the main bearing caps. In order to prevent hydraulic lock, do not apply oil to the tapped holes in the cylinder block. Install the bolts finger tight and tighten them further with the SPS Torque Sensor I torque wrench^{xx} only working from the center out in a crisscross pattern. See the Sequence IIIG Engine Assembly Manual for torquing instructions. (See section 1 sheet 6 for honing and section 3 sheet 6 for final assembly)

10.7.5.2 Cylinder Head Bolts-The cylinder head bolts, GM Part No. 25527831 (long) and 25533811 (short), are of special design for yield applications and shall only be installed using the SPS Torque Sensor I torque wrench^{xx}. See the Sequence IIIG Engine Assembly Manual for installation instructions. Replace the bolts after each test. (See section 1 sheet 7 for honing and section 5 sheet 3 for final assembly)

10.7.5.4 Torques for Miscellaneous Bolts, Studs, and Nuts-Use the torques for miscellaneous bolts, studs, and nuts given in the Sequence IIIG Engine Assembly Manual.

10.8 Parts Replacement-See 10.8.1 for information regarding parts. Replace test parts as follows:

10.8.1 Install the new parts listed in A2 Table A2.1 for each test.

10.8.2 Install the new parts listed in A2 Table A2.2, only if the used part is no longer suitable for test purposes.

10.9 Engine Block Preparation-Prepare the engine block as follows:

10.9.1 Install new engine block freeze plugs; use a driver to facilitate this replacement.

10.9.2 Install the main bearing caps, without the bearings in place. Tighten the retaining bolts using the procedure in 10.7.5.1.

10.9.3 To prevent entry of honing fluid into the coolant passages of the engine block, cover and seal the coolant inlet passages and freeze plug openings. Close the petcocks, if any were previously installed; if not, install $\frac{1}{4}$ in NPT pipe plugs

10.9.4 Using a 30 cm (12 in) smooth file, deburr the surfaces of the block that mate with the cylinder heads to ensure adequate gasket seating.

10.9.5 The honing torque plates B-H-J GM 3.8L/3E-R-s_t-HT^{xx} shall be used to pre-stress the engine block for honing. Install the torque plates with the proper hardened washers (supplied with the honing torque plates), single washers on top row and double washers on bottom row, to establish proper bolt depth. Clean the threaded bores for the cylinder head attachment bolts using a bottoming tap before each installation of the torque plates. The torque plates require the use of new head gaskets, SPO Part No. 24503801 left head and 24503802 right head, along with cylinder head torque-to-yield fasteners, SPO Part No. 25527831 (long). Clean all sealing and thread locking compounds from the fasteners for the torque plate installation. Coat each fastener with build-up oil and see the Sequence IIIG Engine Assembly Manual for installation instructions. (See section 1 sheet 7)

10.9.6 Use only the CV-616 honing machine^{xx} to hone the cylinder walls. See the Sequence IIIG Engine Assembly Manual section 2 for all of the proper setup and operational procedures for each specific run on the Sequence IIIG Engine block.

10.9.7 Replace the honing fluid, filters, and fiber mats used in the honing machine every 15-h of honing machine operation. Use the honing machine hour meter to determine hours of operation. See the Sequence IIIG Engine Assembly Manual section 2 sheet 8.

10.9.9 The flow rate of the honing lubricant should be approximately 7 L/min (2 gal/min). In addition, solvents shall not be introduced into the honing fluid or used to clean the

honing stones or guides. Only honing fluid is permitted to clean honing stones or guides.

10.9.11 Hone the cylinder walls without the main bearings in place, but with all bearing caps installed

10.9.12 Clean the engine block following honing according to 10.5.3.1.

10.9.13 Check the main bearing bore clearances using a mandrel, part BX-398-1, according to the following procedure:

Starting from the front of the block, slide the mandrel through all four main bearing bores. If excessive resistance is encountered while inserting the mandrel, remove the mandrel from the engine block and inspect the main bearing bores for burrs, nicks, dirt, alignment problems, or any abnormalities. Use 400 grit paper or a fine stone to carefully remove any nicks, burrs, scratches, or dirt. Then use a clean shop towel with ~~aliphatic naphtha~~ mineral spirits to wipe the affected surfaces. Reinstall the mandrel to ensure that it can freely pass through all four main bearing bores. If the mandrel will not clear the bores after the above steps have been completed, the block should not be used. Notify the Test Developer of the problem. After honing, the above procedure should be repeated prior to final engine build. The mandrel is an alignment and clearance gage only, not an assembly tool. The mandrel should not be in the bores when installing the main bearing caps or torquing the main bearing bolts.

10.10 Piston Fitting and Numbering-Fit the pistons to the cylinders according to recommendations listed in the Sequence IIIG Engine Assembly Manual for the run sequence of the block. Use only the specified code pistons for each run sequence. Number the pistons with odd numbers in the left bank from front to rear and with even numbers in the right bank from front to rear.

10.10.1 Piston Rings- The rings are pre-sized for each run and the gap shall be checked in the cylinder bore for each test. The top ring gap shall be $0.635 \text{ mm} \pm 0.051 \text{ mm}$ ($0.025 \text{ in} \pm 0.002 \text{ in}$). The bottom ring gap shall be $1.067 \text{ mm} \pm 0.051 \text{ mm}$ ($0.042 \text{ in} \pm 0.002 \text{ in}$). The top ring gap shall be smaller than the bottom ring gap and the difference between the two ring gaps shall be between 0.381 mm and 0.483 mm (0.015 in and 0.019 in). If the ring gap difference is below 0.381 mm (0.015 in) contact the Test Developer. Check the ring gap with a Starrett Ring Taper Gage No. 270^{xx} with the ring positioned in the cylinder bore using a piston ring depth gage (drawing RX-118602-B). Rings shall be positioned at 23.67 mm (0.932 in) below the cylinder block deck surface during gap measurement. Record the top and bottom ring gaps on

Form 12, Hardware Information, in standardized report form set (See A6). Ring gaps shall be recorded and reported in mils (1 mil = 0.001 in).

** A Starrett Ring Taper Gage No. 270 has been found suitable. It is available from commercial sources.

10.11 Pre-Test Camshaft and Lifter Measurements-Measure the camshaft lobe height and lifter lengths, prior to engine assembly, according to the following procedure:

10.11.1 The camshaft measurement shall be made using a Mitutoyo Snap Gauge, model 201-152, and a Mitutoyo Digital Indicator, model 543-252B, to measure the camshaft lobes. The lifter measurements shall be made using a digital indicator, equipped with a Mitutoyo 4.3mm flat point, model 131-259, mounted in an indicator stand. The indicator stand shall be equipped with a V-block that is rigidly mounted to the base and locates the lifter with its center axis in line with the digital indicator.

10.11.1.1 Use dimensional measuring equipment accurate to 0.001mm. Before each measurement session, use standards traceable to the National Institute of Standards and Technology, to ensure measuring equipment accuracy. Include standards having length values within 1.3 mm (0.05 in.) of the typical lifter and lobe measurements taken. Use the same equipment and standards for post-test measuring as were used for pre-test measuring. If a calibration shift between pre-test and post-test measurements is detected, evaluate the shift to determine its effect on the wear measurements. Record the results of the evaluation, and any corrective action taken.

10.11.2 With the camshaft positioned in a set of V-Blocks, Remove any burrs around the outer edge of the camshaft thrust surface, if necessary.

10.11.3 Thoroughly clean the camshaft by spraying with ~~aliphatic-naphtha~~ mineral spirits to remove all rust preventative coatings (Warning-see Note 36) and blow-dry it with clean, dry shop air. (Warning-see Note 37)

Note-36: Warning-Combustible. Health Hazard.

Note-37: Warning-For technical use only.

10.11.4 Measure the maximum pre-test dimension of each camshaft lobe, transverse to the camshaft axis to the nearest 0.001 mm (0.00004 in.). This dimension is at the rear edge of all lobe positions (lobes are numbered from the front to the rear of the camshaft). Record the measurements on internal laboratory forms. See 10.7.

10.11.5 Measure the pre-test length of the lifters at the center of the lifter foot to the nearest 0.001 mm (0.00004 in.). Record the measurements on internal laboratory forms. See 10.7.

10.11.6 Record the unique serial number for each lifter on internal laboratory forms. See 10.7. Do not use electro-mechanical scribing devices. Do not place any marks on the lifter body or foot.

10.12 Camshaft Bearing Installation-The camshaft tunnel is specially processed and uses oversize bearings provided through the CPD. Install the camshaft bearings according to the Sequence IIIG Engine Assembly Manual sheet 3 sheet 3. Always inspect the lifter and main bearing oil galleries for splintered babbit materials that might have been shaved from the outside diameter of the bearings during installation. Remove any materials from the oil galleries with clean dry shop air. (Warning-see Note 38)

Note-38: Warning-For technical use only.

10.13 Camshaft Installation-Install the special test camshaft, part number OHT3F-008-8, according to the Sequence IIIG Engine Assembly Manual section 3 sheet 11:

10.13.1 Coat the camshaft journals with a light film of build-up oil on the journals.

Note-39 Camshafts should not sit with dry cam lobes inside the engine block waiting for final assembly more than 24 hours.

10.13.2 Install the camshaft in the engine block, taking care to avoid damage to the lobes, journals, and bearings.

10.13.3 Installation of Camshaft Thrust Plate-Lubricate the thrust plate with build-up oil and install the thrust plate to the front of the engine block using the Torx[®] fasteners.

10.14 Main Bearings-Verify that the main bearing bore areas in the engine block and bearing caps are clean. Install new main bearings, part number OHT3F-042-2, in the engine block and main bearing caps, and lightly oil the bearing surfaces with build-up oil.

10.14.1 Crankshaft-Install the crankshaft.

10.14.2 Main Bearing Cap Installation-Install the main bearing caps; use a rubber or plastic mallet to seat the caps. Do not use air tools on the main bearing cap bolts to seat the caps. Install the bolts finger tight, and tighten them according to the

procedure in 10.7.5.1. The main bearings should be used as received.

10.15 Crankshaft Sprocket, Install a matched set two-piece crankshaft sprocket, part number OHT3F-036-1.

10.16 Camshaft Sprocket, and Timing Chain -Install a new camshaft sprocket and timing chain.

10.17 Crankshaft End Play-Measure the crankshaft end play. It should be between 0.076 mm and 0.279 mm (0.003 and 0.011 in.).

10.18 Piston Pin Installation- Install new piston pins and retainers for each test. Clean piston pins using a clean lint free cloth and oil with build-up oil. The piston pins are full floating and held in place by two retainers.

10.18.1 Piston Installation- Clean pistons using ~~aliphatic naphtha~~ mineral spirits and air dry prior to installation. Install the pistons according to the following procedure:

10.18.2 Piston rings are pre-gapped, see section 10.10.1, use a piston ring expander ^{xx} to install the rings on the pistons.

10.18.3 Position the ring end gaps as shown in the Sequence IIIG Engine Assembly Manual section 3 sheet 8.

10.18.4 Coat the cylinder walls with build-up oil and wipe them with a clean, lint-free soft cloth, repeating the process until clean; apply a final coat of build-up oil before installing the piston assembly.

10.18.5 Coat the pistons and rings with build-up oil.

10.18.6 Install the pistons in the cylinders, using a ring compressor tool.^{xx}

10.19 Harmonic Balancer-Deburr the harmonic balancer keyway slot and the slot on the crankshaft with a mill file. The balancer must not be installed until after the oil pump priming operation has been performed in the test stand just prior to test start.

Note-40: To make the balancer a slip fit, remove the rolled edge on the inside diameter of the balancer until the balancer slips easily over the crankshaft.

10.20 Connecting Rod Bearings- Clean the bearings using a clean lint free cloth and oil with build-up oil prior to installation. Use new connecting rod bearings, part number OHT3F-042-2, for each test, furnished as part of the engine bearing kit.

10.20.1 Install the bearings in the connecting rods, and install the bearing caps with the rods in place on the crankshaft.

10.21 Engine Front Cover-Use a new front cover with each new engine block or if the oil pump gerotor housing is worn.

10.21.1 Install new oil pump gears, or a new front cover and new gears, as deemed necessary according to the Sequence IIIG Engine Assembly Manual inspection requirements section 4 sheet 2.

10.21.2 Install a new oil pump relief valve and spring.

10.21.3 Ensure the oil pump relief valve moves freely inside its bore in the front cover. Check the oil pump relief valve clearance according to the Sequence IIIG Engine Assembly Manual section 4 sheet 4.

10.21.4 Bolt the front cover and oil pump assembly to the engine block.

10.21.5 Inspect the oil pickup tube and screen assembly for cleanliness and install using a new gasket.

10.22 Coolant Inlet Adapter-Replace the water pump with a coolant inlet adapter as shown in drawing OHT3F-031-1.

10.23 Oil Dipstick Hole-Plug the oil dipstick hole with a hole plug (Part OHT3F-065-2). This plug is removed and the calibrated dipstick (Part ~~OHT3F-064-2~~ OHT3G-064-1) is inserted to determine the oil level at the appropriate time during a test.

10.24 Oil Pan-Install the oil pan, part number OHT3F-073-1, on the engine block, using a new gasket. Do not use magnetic drain plugs in the pan.

Note-41: Ensure the cut out area of the windage tray / oil pan gasket does not interfere with the oil dip stick and modify if necessary.

10.25 Cylinder Head Assembly-Prepare the cylinder heads according to the following procedure:

10.25.1 Install new cup-type freeze plugs.

10.25.2 Deburr all surfaces of the cylinder heads which mate with the engine block and the manifolds with a 30-cm (12-in.) smooth file to ensure satisfactory gasket seating.

10.25.3 Thoroughly clean the cylinder heads according to section 10.6 and air (Warning-see Note-43) blow them dry prior to final assembly.

Note-42: Blank

Note-43: Warning-For technical use only.

10.25.4 Coat the valve stems and valve guides with build-up oil.

10.25.5 Install new ~~the~~ valves for each test. Lapping or grinding of valves and/or valve seats is not allowed. ~~and lightly lap them if desired. Clean the cylinder heads after lapping to ensure that no lapping compound remains on any parts. The valves shall be installed in the location where lapped for final assembly.~~

10.25.6 Install new valve stem seals over the valve stems onto the valve guides. Exercise extreme care when installing the seals in order to avoid either cutting the seals or mis-positioning them on the guides, thereby helping to preclude high oil consumption. See Sequence IIIG Engine Assembly Manual section 5 sheet 1.

10.25.7 Install new valve springs, part number OHT3G-059-1 (color code pink). Place the smaller diameter end of the spring against the retainer.

10.25.8 Install valve retainers and keepers.

10.26 Adjustment of Valve Spring Loads-Adjust the load of each valve spring according to the following procedure:

10.26.1 Before and after using the valve spring load measurement apparatus (such as Part BX-310-2¹⁸), calibrate the load cell using the following technique. Use dead weights to produce the specified load of ~~801 N (180 lbf).~~ 912 N (205 lbf).

Load Cell to Load Cell Technique

Affix load cell weight adapter plate (see Fig. 1) to calibration load cell. Zero the calibration load cell. Individually place calibrated dead weights onto calibration load cell. Verify that each dead weight indicates the appropriate load on calibration transducer readout. Repeat the calibration of the calibration load cell. The two consecutive readings shall agree within ± 0.5 lbs.; if not inspect the load cell and replace if necessary. Align calibration load cell beneath apparatus load cell. Place the air cylinder ram on the calibration load cell. Set the apparatus load cell to read the value of the calibration load cell. Apply air pressure to the aligned load cells. Vary air pressure to give several different loads, including ~~180 lbs~~ 205 lbs. Determine that both calibration and apparatus transducer

readouts indicate the same value, if not, adjust the apparatus load cell. Repeat the calibration of the valve spring load measurement apparatus. The two readings shall agree within ± 0.5 lbs.; if not inspect the apparatus load cell and replace if necessary. Retain data obtained during each calibration.

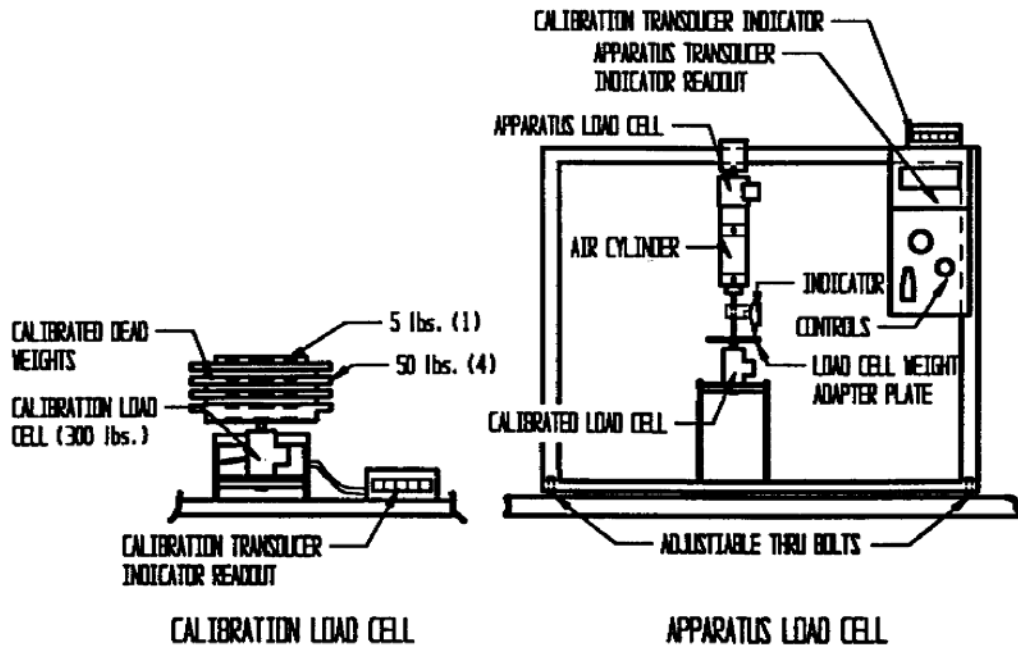

FIG. 1 Load Cell-to-Load Cell Calibration Method Diagram

10.26.2 Install a cylinder head in the holding fixture. The holding fixture shall position the cylinder head such that the valve is directly in line with the air cylinder loading unit and no side loading of the valve takes place.

10.26.3 Install zeroing fixture, part D4031^{xx}, to cylinder head. Zeroing fixture, Part D4031, is part of the valve spring load measurement apparatus, Part BX-310-2.

10.26.4 Place the air cylinder loading unit over a valve and check for proper alignment of the valve tip with the loading unit.

10.26.5 Position the dial indicator and its foot on the zeroing fixture in order to accurately measure the axial movement of the valve stem.

10.26.6 Rapidly apply and release the air pressure three times to ensure free travel of the piston rod; adjust the air pressure to obtain a valve deflection reading of 9.5 mm (0.375 in.), if necessary.

10.26.7 If the readings are not within the specifications of $912 \text{ N} \pm 22 \text{ N}$ (205 lbf \pm 5 lbf) load as shown by the load cell indicator, add or remove shims, or interchange parts as necessary. Repeat steps 10.26.2 through 10.26.7.

10.27 Cylinder Head Installation-New head gaskets, shall be used for each application. Do not use any sealers on the cylinder head gaskets. New fasteners shall be used for each application. Before using the fasteners for cylinder head attachment, all pre-coat sealers and thread locking compounds should be removed from the threads and underside of the bolt head using a wire wheel or brush. Do not use chemical cleaners to remove these coatings. Coat the threads and underside of the bolt head (360°) using non-hardening pliable sealing compound^{xx}. Tighten the fasteners according to the guidelines in the Sequence IIIIG Engine Assembly Manual section 5 sheet 3.

10.28 Hydraulic Valve Lifters-Do not open the hydraulic lifter to expose any part of the internal parts. Do not remove the factory-installed leak down oil. Do not electro mechanically etch identification numbers on the hydraulic lifters.

10.28.1 Prior to installation, clean the lifter body and foot using a clean cloth dampened with ~~aliphatic-naphtha~~ mineral spirits (Warning-see Note-43). Do not submerge or spray the

hydraulic lifter. Gently wipe the lifter body and foot with the dampened cloth and dry using a clean dry cloth or terry towel.

Note-43: Warning-Combustible. Health Hazard.

10.28.2 Install the test lifters in the test engine, coating each lifter foot with test oil before installation into the lifter bore. Rotate the engine crankshaft slowly for 720° while insuring that the lifters follow the cam lobe profile. Remove each lifter and once again coat the lifter foot with test oil. Reinstall the lifter into the engine block with the ground flat on the lifter body facing inboard toward the center of the engine. See the Sequence IIIG Engine Assembly Manual section 6 sheet 1.

10.29 Pushrods-Clean the pushrods with ~~aliphatic naphtha~~ mineral spirits (Warning-see Note-44), and air (Warning-see Note-45) blow them dry prior to installation; make certain that the oil passages are open. Lubricate the ball ends of the pushrods with buildup oil and install the pushrods. See the Sequence IIIG Engine Assembly Manual section 6 sheet 2.

Note-44: Warning-Combustible. Health Hazard.

Note-45: Warning-For technical use only.

10.30 Valve Train Loading-Install the rocker arm pivot retainer and the precision roller rockers and torque the rocker arm pedestal bolts according to the Sequence IIIG Engine Assembly Manual section 6 sheet 4.

Note-46 Once the valve train is loaded, the engine shall not be rotated until the start of test using the dynamometer air starter system.

10.31 Intake Manifold-Modify the intake manifold as shown in the Sequence IIIG Engine Assembly Manual section 6 sheet 7.

10.31.2 Plug the EGR port using part number OHT3-024-1.

10.31.3 Install the positive crankcase ventilation valve replacement plug, part number OHT3F-002-1, in the intake manifold plenum.

10.32 Rocker Covers-Install two left side rocker covers part #25534751 on the cylinder heads.

10.33 Water outlet Adapter-Install a water inlet adapter made according to drawing OHT3F-034-1.

10.34 Condenser-Install a condenser mounting bracket, part number OHT3F-041-1, and condenser, part number BX-212-1 or OHT3F-075-1¹⁶, with an adapter, part number OHT3F-040-1, on the front of the engine using flexible hose to connect the adapter to the rocker cover bushings, part number OHT3F-028-1.

10.35 Coolant Outlet Adapter-Replace the thermostat housing with a coolant outlet adapter, part number OHT3F-034-1.

10.36 External Oil Cooling System-Install the external oil cooling system as follows:

10.36.1 ~~Install a modified Modify an~~ Oil Filter Engine Adapter, part number ~~OHT3F-080-1-24501300, by removing the oil bypass valve.~~ Refer to Section 4 Sheet 4 and Section 8 Sheet 3a of the Sequence IIIG Engine Assembly Manual. Install the adapter on the engine front cover.

10.36.2 Install an Oil Cooler, part number OHT3F-030-2, using Connector part number OHT3F-039-3, as shown in the Sequence IIIG Engine Assembly Manual section 8 sheet 3.

10.36.3 Install an Oil Filter Adapter Fitting, part number OHT3F-043-2, and an Oil Filter Adapter, part number OHT3F-035-2, as shown in the Sequence IIIG Engine Assembly Manual section 8 sheet 3.

10.36.4 Install the Bypass Valve Assembly Housing, part number OHT3F-084-1, on the Oil Filter Engine Adapter, as shown in the Sequence IIIG Engine Assembly Manual section 8 sheet 3a.

10.37 Oil Sample Valve-Install suitable plumbing to the oil pressure fitting located in the oil filter adapter to permit the removal of oil samples. Select the plumbing to minimize the added volume.

10.38 Ignition System-Install ignition system components according to the following instructions:

10.38.1 Use high-energy ignition wires which are resistant to moisture and high temperatures.^{xx}

10.38.2 Use an original equipment manufacturer coil pack mounted on the front engine mount according to drawing OHT3F026-1.

10.38.3 Use new spark plugs; **NGK** part number TR6, stock number 4177^{xx}. Adjust the gaps with a wire gage to 1.14 mm (0.045 in.) Install a set of plugs prior to test start-up. Tighten spark plugs hand-tight plus 1/16 of a turn.

xx NGK spark plugs are available from commercial sources.

10.39 Throttle Body Modify a production throttle body according to the drawing in the Sequence IIIG Engine Assembly Manual section 7 sheet 5.

10.39.1 Install the throttle body onto the plenum and attach the throttle body adapter, part number OHT3F-001-2.

10.40 Accessory Drive Units-Do not use any accessory drive units, such as alternators, generators, fuel pumps, power steering units, air pumps, etc.

10.41 Exhaust Manifolds, Water-Cooled-Prepare two water-cooled exhaust manifolds, part number OHT3F-003-1, and install one on each of the two cylinder heads using transition adapters, part number OHT3F-004-1, according to the following instructions:

10.41.1 Deburr all the surfaces of the exhaust manifolds which mate with the cylinder heads with a 30-cm (12-in.) smooth file to ensure proper gasket seating.

10.41.2 Attach the exhaust manifolds to the heads using stainless steel studs (3/8-16 x 3/8-24 x 1 1/2 in.), stainless steel 3/8-24 nuts, and shielded exhaust gaskets, part number OHT3F-018-1 or GM 24506009.

Note-47: Ensure that there are no leaks between the manifold assembly components that might allow outside air to enter the exhaust system through scavenging up stream of the O₂ sensor.

10.42 Engine Flywheel-Install the flywheel and drive shaft plate assembly OHT3F-020-2

10.43 Pressure Checking of Engine Coolant System-If desired, pressure check the engine coolant system after assembly and before installation of the engine on the test stand, according to the following procedure:

10.43.1 Block all coolant outlets, and install the necessary fittings on the coolant inlet to permit pressurizing the coolant system with air, and sealing it.

10.43.2 Pressurize the coolant system with air to 100 kPa (30 in. of Hg) (Warning-see Note-48), and seal it. Monitor the pressure for 10 min. Take no corrective action if the reduction in pressure is less than 3.4 kPa (1 in. of Hg) in 10 min. If larger changes in pressure are observed, re-torque all appropriate bolts, and replace gaskets, seals, and components (including the cylinder

heads and the intake manifold) as necessary. Repeat the pressure checking.

Note-48: Warning-For technical use only.

10.44 Lifting of Assembled Engines-Lift the assembled engines with a suitable lift chain.^{xx}

10.45 Mounting the Engine on the Test Stand-Mount the engine on the test stand according to the following:

10.45.1 Use OHT3F-026 front and OHT3F-025 rear engine mounts.

10.45.2 Mount the engine in such a manner that the intake plenum mounting flange-to-intake manifold interface is horizontal.

10.45.3 Install an engine flywheel guard, safety housing, and air starter mounting assembly (part of OHT3F-025).

10.45.4 Connect the engine to the dynamometer with a flywheel-to-driveshaft coupling adapter (part of OHT3F-020-1) and a driveshaft.^{xx}

10.45.5 Install a coolant drain valve in the middle of each side of the block, in the 1/4-in. NPT hole. The use of street ells and petcocks has been found satisfactory. (Installation of petcocks will be assumed for the remainder of this test method.)

10.46 External Cooling System Cleaning-Clean the external cooling system of either a new or used test stand, or a new flushing tank assembly. Clean the used test stand system periodically, typically before a reference test. Use the following procedure:

10.46.1 Remove all galvanized materials from the system.

10.46.2 Prepare a cleaning mixture in the flushing tank (drawing RX-116924-C) by mixing 19.0 g/L Sequence IIIF test component cleaner (Warning-see Note 61) (see 7.4) with water. Heat the mixture to $60 \pm 2.8^{\circ}\text{C}$ ($140 \pm 5^{\circ}\text{F}$).

Note-49: Warning-Corrosive. Health Hazard.

10.46.3 Circulate the mixture at 160 L/min (42.3 gpm) flow rate for 30 min.

10.46.4 Immediately following step 10.46.3, thoroughly flush all system components with water at $60 \pm 2.8^{\circ}\text{C}$ ($140 \pm 5^{\circ}\text{F}$).

10.46.5 Ensure that all low points in the system are drained after cleaning.

10.47 Engine Coolant Jacket (Flushing)-After the engine has been installed on the test stand, chemically clean the engine coolant jacket to ensure the proper rate of heat transfer to the jacket coolant, according to the following procedure:

10.47.1 Connect the flushing tank to the engine so that the cleaning solutions enter at the coolant outlet adapter and exit at the front of the engine block (reverse flow only for flushing) through the water inlet adapter.

10.47.2 Connect the coolant outlet hose located at the front of the engine intake manifold to the flush cart return for this procedure.

10.47.2.1 The coolant outlet hose connected to the intake manifold shall be equipped with a suitable ½" ball valve. This valve shall be closed during the flushing portion of the procedure using the Sequence IIIG Test Component Cleaner. The valve shall be open during the water rinse portion of the procedure.

10.47.3 For the following segments of this cleaning procedure, minimize the elapsed time between steps in order to avoid rusting of the coolant jacket.

10.47.4 Remove the oil pan drain plug. Open the engine block petcocks and pass water heated to 60 to 70°C (140 to 158°F) through the engine coolant jacket for 2 min. Check for water leaks around the intake manifold, front cover, rear cover, and oil pan drain plug. (Note: the oil pan will hold approximately 384 ml (13 oz.) of water before leaking out of the oil drain plug) If water is leaking, take appropriate steps to stop the leak. If no leaking is evident, close the petcocks and fill the flushing tank and engine block with water to provide a total volume of 38 to 45 L (10 to 12 gal).

10.47.5 Energize the flushing tank heaters. Circulate water through the engine at a flow rate of 115 to 130 L/min (30-35 gpm) through the engine until the temperature of the water flowing out of the engine reaches $70 \pm 3.0^{\circ}\text{C}$ ($158 \pm 5.0^{\circ}\text{F}$). Isolate the engine from the flush cart.

10.47.6 While the flush cart is isolated from the engine with water still circulating, add 19 g/L Sequence IIIG test component cleaner (Warning-see Note-50) (see 7.4) to the water in the flushing tank. ~~Continue~~Continue to circulate the mixture in the flush cart for 3-5 minutes.

Note-50: Warning-Corrosive. Health Hazard.

10.47.7 Circulate the mixture through the engine for 30 min.

10.47.8 Stop the circulation pump, open the engine block petcocks, and drain the contents of the engine and flushing tank into a suitable container. (See Note 51)

Note-51: The drained material should be neutralized before disposal according to applicable local and federal hazardous material guidelines.

10.47.9 Open the ball valve in the coolant outlet hose on the intake manifold. With the engine block petcocks closed, flow hot tap water through the engine and flush cart system for 2 to 5 min. The water flowing through the engine during this step shall make a single pass through the engine and flush cart. Continue flowing water through the engine until the pH of the water flowing out of engine is neutral. Check the pH of the rinse water at the return port in the flush cart tank. (See Note 51a)

Note-51A: The rinse water should be neutralized before disposal according to applicable local and federal hazardous material guidelines.

~~10.47.9 Close the engine block petcocks and flow hot tap water through the engine into the flush cart, for 2 to 5 min, until the pH of the water flowing out of the engine is neutral. Use water at a temperature of 60 to 70°C (140 to 158°F). Maintain a flow rate of 76 to 95 L/min (20 to 25 gal/min). (See Note-51)~~

10.47.10 Immediately after neutralizing the engine block in 10.47.9, open the block petcocks and drain all flush water.

10.47.11 Disconnect the flush cart plumbing and remove any trapped water in the intake manifold plumbing by blowing compressed air through coolant outlet on the rear of the engine block.

10.47.12 Connect the engine to the external engine cooling system.

10.47.13 Immediately charge the engine jacket with coolant.

10.48 Coolant Charging-Charge the engine jacket with the specified coolant (See 7.3) (Warning-see Note-54), according to the following procedure:

Note-54: Warning-Combustible. Health Hazard.

10.48.1 To preclude contamination of the coolant system with water, install low-point drains and eliminate all traps in the system. Drain all water in the system.

10.48.2 Use a charging adapter installed between the external cooling system and the engine.

10.48.3 Completely fill the engine jacket and cooling system with coolant (see 7.3). (Warning-see Note-55) Fill the engine coolant jacket before filling the condenser system.

Note-55: Warning-Combustible. Health Hazard.

10.48.4 Charge the condenser coolant system immediately after charging the engine cooling system.

10.48.5 Operate the circulating pumps to aid in the removal of air and consequently decrease the time to achieve clarity of the coolant. During this period, operate any proportioning valves in the coolant system several times.

10.48.6 Until the test is started, circulate the coolant at a temperature of $48.9 \pm 2.8^{\circ}\text{C}$ ($120 \pm 5^{\circ}\text{F}$) and a flow rate of 160 L/min (40 gpm). Start the test no later than 6 hours after step 10.48.5

10.49 Test Oil Charging-Charge the engine with the test oil as follows:

10.49.1 Install a new oil filter OHT3F-057-2.

10.49.2 Add an initial fill of 5.50 L (5 qt, 26 oz) of fresh test oil through the rocker cover oil fill cap using a calibrated container, calibrated via NIST^{xx} traceable standard.

^{xx} National Institute of Standards and Technology

10.50 Engine Oil Pump Priming-Prime the engine oil pump according to the following instructions:

10.50.1 With the harmonic balancer and front half of the oil pump drive gear OHT3F-036-1 removed, use a suitable high torque drill motor rated at 7 to 9 amps at 2400 (no load) rpm for driving the oil pump drive tool OHT3F-038-1 rotating the gerotor oil pump in a clockwise direction (viewed from the front of the engine) for two minutes after indication of oil pressure. The Dewalt model DW515 has been found suitable for this application.

10.50.2 Replace the front half of the oil pump drive gear and the harmonic balancer and torque the harmonic balancer to 150 N•m+ 76° (111 lb•ft. + 76°).

10.50.3 Connect the crankcase pressure line and oil sample valve fittings in preparation for testing, and proceed with the initial run (see 12.14).

11. Calibration

11.1 Laboratory and Engine Test Stand Calibration-To maintain testing laboratory and engine test stand calibration status for Sequence IIIG Engine oil testing, follow these directions:

Note-56 Annexes A1 and A5 cover the involvement of the ASTM TMC in respect to calibration procedures and acceptance criteria for a testing laboratory and a test stand, and the issuance of Information Letters and memoranda affecting the test method.

11.2 Testing of Reference Oils-Periodically conduct tests on reference oils according to the following:

11.2.1 Reference oil tests conducted on each test stand within a laboratory, which is to be considered calibrated, must be conducted according to ASTM Test Monitoring Center guidelines.

11.2.2 Obtain reference oils directly from the ASTM TMC. These oils have been formulated or selected to represent specific chemical types or performance levels, or both. They are usually supplied directly to a testing laboratory under code numbers to ensure that the laboratory is not influenced by prior knowledge of acceptable results in assessing the test results. The ASTM TMC will determine the specific reference oil to be tested by a laboratory.

11.2.3 Unless specifically authorized by the ASTM TMC, do not analyze reference oils, either physically or chemically. Identification of reference oils by such analyses could undermine the confidentiality required to operate an effective reference oil system. Therefore, reference oils are supplied with the explicit understanding that they will not be subjected to analyses other than those specified in this procedure, unless specifically authorized by the ASTM TMC. If so authorized, prepare a written statement of the circumstances involved, the name of the person authorizing the analysis, and the data obtained; furnish copies of this statement to both the ASTM TMC and the Test Developer.

11.2.4 Assign a stand test number to each Sequence IIIG test. The number must include the ~~the~~ stand number, the number of Sequence IIIG tests conducted on the stand since the last reference oil test was conducted (0 to 15), and a sequential laboratory test number based on the starting date of the test. For example, 60-03-785 defines a Sequence IIIG test on stand number 60, which is the third non-reference oil test run on stand 60 since successful completion of a reference oil test, and was the 785th Sequence IIIG test in the laboratory. The only exception to this format is that the sequential laboratory test number shall be followed by the letter A for the first rerun, B for the second, etc. for invalid or unacceptable reference oil tests.

11.3 Reference Oil Test Frequency-Conduct reference oil tests according to the following frequency requirements:

11.3.1 For a given calibrated test stand, conduct an acceptable reference oil test after no more than 15 test starts have been conducted, or after 120 days have elapsed, whichever occurs first.

11.3.2 For a given testing laboratory with more than one calibrated test stand, conduct an acceptable reference oil test after no more than 90 days have elapsed since the last reference oil test.

11.3.3 After a laboratory reference oil test is started, non-reference oil tests may be started on any other calibrated test stands.

11.3.4 The ASTM TMC may schedule more frequent reference oil tests at their discretion.

11.3.5 Under special circumstances, such as extended downtime caused by industry-wide parts or fuel shortages, the ASTM TMC may extend the intervals between reference oil tests.

11.4 Reporting of Reference Oil Test Results-Report the results of all reference oil tests to the ASTM TMC according to the following directives:

11.4.1 Results are to be transmitted to the TMC within 5 days of test completion via electronic data transfer protocol as outlined in the Data Communication Committee Electronic Test Report Transmission Model (ETRTM). The ETRTM can be obtained from the TMC.

11.4.2 If the test was conducted during a time extension permitted by the ASTM TMC, so indicate in the Comments section of the test report.

11.4.3 For an acceptable reference oil test, conducted following an unacceptable reference oil test. Provide sufficient information in the Comments section of the test report to indicate how the problem was identified and corrected, insofar as possible, and how it was related to candidate oil tests conducted during the period of time that the problem was being solved.

11.4.4 Send by mail one copy of the standard final report (Use the report forms supplied by the ASTM TMC. Report forms can be obtained from the TMC web site: <ftp://astmtmc.cmu.edu/datadict/> or by contacting the TMC.) to the Test Developer, and one copy of the report to the ASTM TMC, at

the following addresses in order that the records are received within 30 days of test completion.

General Motors Powertrain
Research and Development Center
Mail Code 480-106-160
Sequence IIIG Test Coordinator
30500 Mound Road
Box 9055
Warren, MI 48090-9055

Test Report Clerk
ASTM Test Monitoring Center
6555 Penn Avenue
Pittsburgh, PA 15206

11.5 Evaluation of Reference Oil Test Results-The ASTM TMC will evaluate the reference oil test results for both operational validity and statistical acceptability. The TMC may consult with the Test Developer, and test laboratory in case of difficulty, as follows:

11.5.1 Immediately upon receipt of the reference oil test results from the test laboratory, the ASTM TMC will evaluate the laboratories decision on operational validity. For operationally valid tests the TMC will then evaluate the pass/fail parameters according to the Sequence IIIG Lubricant Test Monitoring System (ASTM TMC Memorandum 94-200). If the test is judged acceptable, the reference oil code will be disclosed by the ASTM TMC to the test laboratory. The ASTM TMC will convey its preliminary findings based on the limited information available to them, to the test laboratory.

11.5.2 Subsequently, upon receipt of the information detailed in 11.4.4, the ASTM TMC will review all reference oil test results and reports to determine final test acceptability.

11.5.3 In the event the reference oil test is unacceptable, an explanation of the problem relating to the failure should be provided by the test laboratory. If the problem is not obvious, all test-related equipment must be re-checked. Following this re-check, the ASTM TMC will assign another reference oil for testing by the laboratory.

11.5.4 The ASTM TMC will decide, with consultation as needed with industry experts (testing laboratories, Test Developer, members of the ASTM Technical Guidance Committee and of the Surveillance Panel, etc.), whether the reason for any failure of a reference oil test is a false alarm, testing stand, testing

laboratory, or industry-related problem. Industry problems must be adjudicated by the Sequence IIIG Surveillance Panel.

11.6 Status of Non-Reference Oil Tests Relative to Reference Oil Tests-Non-reference oil tests may proceed within a given laboratory during reference oil testing based upon the following:

11.6.1 During the time that a reference oil test is being conducted on one test stand, non-reference oil tests may be conducted on other previously-calibrated stands. If the reference oil test is acceptable to the ASTM TMC, the non-reference oil tests will be considered to have been run in a satisfactorily calibrated laboratory.

11.6.2 If a reference oil test is unacceptable, and it is determined that the problem is isolated to an individual test stand, other test stands will be considered to remain calibrated, and testing of non-reference oils may proceed on those other stands.

11.6.3 If a reference oil test is unacceptable, and it is determined that the problem is laboratory related, non-reference tests running during the problem period must be considered invalid unless there is specific evidence to the contrary for each test.

11.7 Status of Test Stands Used for Non-Standard Tests-If a non-standard test is conducted on a previously calibrated test stand, conduct a reference oil test on that stand to demonstrate that it continues to be calibrated, prior to running standard tests.

11.8 Data Acquisition and Control-The Sequence IIIG test requires the use of computerized data acquisition and control for all measured and controlled parameters outlined in this procedure. The system chosen by individual testing laboratories must be capable of integrating with the Sequence IIIG Process Controller for many of these operations. The system must also be capable of meeting or exceeding certain test specific performance requirements for maximum allowable response times and minimum allowable sample rates. In addition to the aforementioned requirements, the system must also be capable of data logging to test specific archival files for each test parameter at minimum allowable record intervals, i.e., no greater than two-minute intervals between successive logs for each parameter. See the Data Acquisition and Control Automation II Task Force Report ** and additional requirements as outlined in this procedure.

11.8.1 Sample Rate-The preferred sample rate is 100Hz with the minimum allowable sample rate for the Sequence IIIG data acquisition and control system set at 1Hz.

11.8.2 Measurement Accuracy- All measurement devices used for sensing speed, load, flow, pressure, and temperature must meet the minimum requirements as outlined in the DACA II report and also conform to total system response requirements as outlined by the TMC. The following is a list of minimum requirements for Sequence IIIG testing:

11.8.3 Temperature-Use only iron-constantan (type J) thermocouples with an accuracy of $\pm 0.5^{\circ}\text{C}$ over a range of 0-200°C.

11.8.4 Pressures-For pressures >6.9 kPa, use only measuring devices with an accuracy of $\pm 0.2\%$ of full scale for capacitive systems and $\pm 0.25\%$ of full scale for strain type systems. For pressures <6.9 kPa, use only devices with an accuracy of ± 15 Pa for capacitive and ± 14 Pa for strain type systems.

11.8.5 Flow-For systems incorporating vortex shedding measuring (liquid) use $\pm 0.75\%$ of reading, vortex shedding measuring (gas) use $\pm 3.0\%$ of full scale. For magnetic measurement use $\pm 1.0\%$ of reading and coriolis measurements use $\pm 0.25\%$ of reading.

11.8.6 Speed-For speed measured by frequency use ± 1 rpm.

11.8.7 Load-For load measured by strain gage use $\pm 0.25\%$ of full scale.

11.8.8 Measurement Resolution-Resolution for all parameters should be at least 4 times greater than the required system accuracy for that parameter i.e., test procedure accuracy = 1.0 units then the minimum resolution of that parameter = 0.25 units.

11.8.9 System Time Response -Total system time response is the time required for the complete data acquisition system including all filtering, transducer lines, and surge tanks to measure a step change input for a given parameter. System response times should be determined by measuring the time required to reach a certain percentage of an imposed step change. For first order systems use the time to 63.2% of the imposed step change and for moving average systems use the time to 45.4% of the imposed step change.

See the TMC System Time Response Measurement Guidelines for methods of imposing step changes for calibration of Sequence IIIG test stands.

See Annex A9 for maximum allowable system time responses for the data acquisition system.

11.8.10 Quality Index-Use of the quality index method of measuring the control capability of the test stand is required for certain parameters. The following formula should be used and a

minimum of 3000 data records are required for the final end of test values.

$$QI = 1 - \frac{1}{n} \sum \left(\frac{U + L - 2X_i}{U - L} \right)^2$$

X_i = Recorded test measurement parameter

U = Upper specification for that parameter

L = Lower specification for that parameter

n = Total number of data points taken as determined from test length and procedural specified sampling rate

The upper and lower values used for QI calculations for the required parameters are listed in Annex A8.

11.8.11 Calibrate the stand instrumentation used for data acquisition and control, on all controlled and non-controlled parameters (see A8), prior to every reference oil test sequence, with the following exception:

11.8.11.1 The intake air humidity system shall be calibrated no less than every six months.

12. Engine Operating Procedure

12.1 Dipstick and Hole Plug-Remove the calibrated dipstick and close off the dipstick hole in the block with the required plug, for all engine operation. See the Sequence IIIG Engine Assembly Manual section 1 sheet 2.

12.1.1 Periodically replace the o-ring on the dipstick hole plug, part number 2-106, to assure a good seal between the plug and the engine block.

12.3 Engine Start-up and Shutdown Procedures-Start and stop Sequence IIIG Engines according to the following procedures and the test states and setpoints listed in A8 Fig. A8.1 and A8.2.

12.4 Start-up-Use the following procedure in starting Sequence IIIG Engines:

12.4.1 Supply 13-15 V direct-current power to the Powertrain Control Module, fuel pump, and all AFR control units for a minimum of 30 seconds before cranking engine to assure all systems are prepared for closed loop AFR control. The lambda sensors are pre-heated and ready for closed-loop control when the AFR readings are over 20:1 prior to engine start.

12.4.2 At the same time start the coolant flowing through the exhaust manifolds.

12.4.3 If the engine fails to start after 5 seconds, the problem must be found and corrective action taken before any further attempts are made. A log entry of any failed attempt and any corrective action must be made in the test report.

12.4.4 When the engine has been started, verify that oil pressure is adequate, and the speed is set to 1500 r/min and the load to 6.34 kW (8.5 bhp).

12.5 Scheduled Shutdown-Use the following procedure in stopping Sequence IIIG Engines:

12.5.1 Reduce the engine speed and load to 1500 r/min and 6.34 kW (8.5 bhp) with a linear ramp down over 30 s (if applicable). Within 90 s, remove the required 472 ml (16 oz) oil purge sample and analysis sample (See 12.7) from the engine oil sampling valve and adjust all temperatures for engine shutdown.

12.5.1.1 Prior to shutdown on the initial run ~~and at the end of test,~~ add the 472 ml (16 oz) purge back to the engine. |

12.5.1.2 Prior to shutdown on all oil levels except the initial and the end of test, add the 472 ml (16 oz) of new oil, plus an additional 59 ml (2 oz) of new oil to the engine prior to shutdown.

12.5.2 Turn off power to the PCM.

12.5.3 With the engine stopped, stop the coolant flow through the exhaust manifolds and continue with the oil sampling and leveling procedure (see 12.7 through 12.8).

12.6 Non-Scheduled Shutdowns-For any non-scheduled shutdowns, record in detail the time off test, the reasons for the shutdown, and any other pertinent observations. Include this record in the test note section of the final test report.

12.7 Oil Sampling- With the engine running at 1500 r/min, remove all oil samples from the engine oil sampling valve according to the following instructions:

12.7.1 Before taking the samples in each of the following steps, first remove a 472-mL (16-oz) purge sample or leveling sample, then remove the oil sample of the specified volume.

12.7.2 Take a 236-mL (8-oz) analysis sample at the end of the initial run (identified as the initial sample) and at the end of the 100-h test.

12.7.3 Take a 59-mL (2-oz) sample at the end of every 20-hours during the test, except at the end of the 100th hour when a 236-mL (8-oz) end of test sample is taken.

12.8 Oil Leveling-Determine the oil level in the crankcase according to the following instructions:

12.8.1 Determine the oil level after the 10-min initial run and after each 20-h of test.

12.8.2 Stop the engine according to the procedure in 12.5 for 15 min to allow the oil to return to the crankcase.

12.8.5 During the 20-min oil leveling period, maintain the condenser temperature at 40°C (104°F) and the engine coolant temperature at 49°C (120°F).

12.8.6 Determine the oil level after the 15-min period, in mm, using the calibrated dipstick. See A3.

12.8.7 Following the initial run, record the oil level on Fig. A10.1, according to 12.8.6. Use this level as the full mark for

the test. Enter 0 (zero) mL as the computed oil level on Fig. A10.1.

12.8.8 After each 20-h of the 100-h test, except at the end of test, add 59ml of new oil to replace the sample taken and also add 472 mL of new oil to the engine.

12.8.9 After each 20-h of the 100-h test, except at the end of test, add oil to the crankcase from the 472-mL leveling sample to bring the oil level back to that following the initial run, as nearly as possible. At the end of test, the entire 472 ml (16 oz) purge sample shall be returned to the engine. Discard any excess leveling sample. Record the results on Fig. A10.1.

12.9 Air-to-Fuel Ratio Measurement and Control-Measure the air-to-fuel ratio using the lambda sensors throughout the test. Control the air-to-fuel ratio using the lambda sensor output as feedback for the Powertrain Control Module. See A7.

12.10 Air-to-Fuel Ratio Verification-Verify the air-to-fuel ratio measurements made by the lambda sensors using exhaust gas analysis according to the following:

12.10.1 By means of exhaust gas analysis, measure the volume percent of CO₂, CO, and O₂, using an electronic gas analyzer.

12.10.2 Enter either Fig. A7.1 or Table A7.1, constructed for the Sequence IIIG fuel, with the CO₂, CO, and O₂ values to determine the air-to-fuel ratio.

12.10.3 For air-to-fuel ratios greater than ~~15:1~~ 14.5:1 (lean), when the analysis shows a CO concentration in the exhaust gas, correct the analysis as follows:

12.10.3.1 Determine the corrected O₂ using this relationship:
Observed % O₂ - 0.5 (observed % CO) = Corrected O₂
(1)

12.10.3.2 Determine the corrected CO₂ using this relationship:
Observed % CO₂ + observed % CO = Corrected CO₂
(2)

12.10.3.3 Enter either Fig. A7.1 or Table A7.1 with the corrected O₂ and CO₂ values to determine the air-to-fuel ratios for the two gases, which must agree within 0.5 air-to-fuel ratio.

12.10.4 Measure the air-to-fuel ratio using exhaust gas analysis during the first hour of the test to insure that the lambda sensors are functioning properly.

12.10.5 Measure the air-to-fuel ratio using exhaust gas analysis during test hours 19, 49, and 99, of the test to insure that the lambda sensors are functioning properly.

12.11 Blowby Flow Rate Measurement-Measure the engine blowby flow rate according to the following instructions, and within 15 min. of the end of test hours: 1, 6, 11, 16, 21, 26, 31, 36, 41, 46, 51, 56, 61, 66, 71, 76, 81, 86, 91, 96, 99.

12.11.1 Observe the following requirements:

12.11.2 Measure the blowby flow rate at the condenser outlet.

12.11.3 Verify that the dipstick hole is sealed during engine operation with the dipstick hole plug.

12.11.4 The blowby meter shall be oriented horizontally during measurements.

12.11.7 Direct the blowby gas into a suitable vent hood at all times other than when the blowby flow rate is being measured. Do not allow the vent system to create a draw on the crankcase.

12.11.8 Connect a surge tank, drawing RX-117431-C, to the condenser.

12.11.9 Connect the blowby flow rate meter to the surge tank.

12.11.10 When permanently installed blowby meters are not used, portable cart applications are allowed. However, position the cart near the testing area for a sufficient time period to assure temperature stabilization of the system components prior to any blowby measurements being taken. Temperature stabilization is necessary to reduce condensation precipitation of the blowby gases. The moisture content of blowby gases are generally between 17 and 20 g/g (120 to 140 grains per lb.). Correction factors are based on this and other average Orsat data of the blowby gases. Therefore, it is important that the blowby gases being measured at the orifice plate be as close in molecular composition and temperature as possible to the blowby gases exiting the condenser.

12.11.11 The exhaust line for the engine blowby gas being measured shall not be evacuated nor directed toward any low pressure evacuation systems.

12.11.12 Select an orifice size such that the observed blowby flow ΔP lies in the midrange of the calibration curve. Record the orifice size used.

12.11.13 Control the crankcase pressure at 0 ± 12.4 Pa (0.0 ± 0.05 in. of water).

12.11.14 Maintain blowby gas flow through the orifice meter for 2 min. or more to ensure flow stability, prior to taking the actual readings. Due to the relatively low flow rates, allow time for the engine blowby gas to fill the system and further enhance temperature stabilization.

12.11.15 Record the uncorrected blowby flow rate in L/min and correct it for an atmospheric pressure of 100 kPa (29.70 in. Hg) and a temperature of 37.8°C (100°F), using the correction factors given in Figure A11.1.

12.11.16 Alternatively, correct the blowby flow rate using the following equations, on which table A8.1 is based:

$$CF_{si} = \left(3.1002 \left(\frac{P_{kpa}}{273.15 + t_{oC}} \right) \right)^{0.5}$$

12.11.17 Disconnect the surge tank from the condenser.

12.12 NO_x Determinations-Measure NO_x concentrations using suitable exhaust gas analysis equipment at 19 h, 49 h, and 99 h. record the data in the report form set.

12.13 Data Recording-Record data at a minimum of every two minutes for all parameters listed in Fig. A8.1.

12.14 Initial run (10 min)-After the engine is charged with the test oil and primed, conduct the 10-min initial run.

12.14.2 Start the engine (see 12.4). Begin timing the 10-min initial run.

12.14.3 Maintain the ignition voltage between 13-15 V.

12.14.4 Make certain that coolant is flowing through the water-cooled exhaust manifolds.

12.14.5 Control the coolant jacket at $50.0 \pm 2.0^\circ\text{C}$ ($122 \pm 3.6^\circ\text{F}$), and the condenser coolant temperature at $40.0 \pm 2.0^\circ\text{C}$ ($104 \pm 3.6^\circ\text{F}$) during the initial run. The temperature control valve for the oil cooler shall be run wide open (maximum cooling) during the initial run.

12.14.6 Operate the engine at 1500 r/min, 6.34 kW (8.5 bhp) for 10 min; check for leaks.

12.14.7 Ten minutes after the start of the initial run, and just prior to stopping the engine, remove a 472-mL (16-oz) purge sample, then take the initial, 236-mL (8-oz), oil sample. After removing the 236-ml (8-oz) oil sample, return the 472-ml (16-oz) purge sample to the engine.

12.14.8 Stop the engine (see 12.5).

12.14.9 Follow 12.7 and 12.8 to determine the oil level after drain-down, in mm; record the value on Fig. A10.1. Use this level as the full mark for the test.

12.15 Engine Oil Quality Testing (100-h)-After completing all phases of the initial run, conduct the 100-h engine oil quality evaluation portion of the test, according to the following procedure:

12.15.1 Start the engine (see 12.4).

12.15.2 Ensure the throttle body humidified air inlet supply to the engine is connected.

12.15.3 Maintain the ignition voltage between 13-15 V.

12.15.4 Operate the engine under the test conditions listed in A8.

12.15.5 For each 20-h segment of the 100-h engine oil quality testing, test time is counted from the moment when all the test conditions listed in A8 are reached and stabilized. Start calculating QI values when temperatures are stable or when test state warm up times are exceeded. See A8. If engine is shut down for any reason except oil leveling, start counting down time. Maximum allowable down time for the IIIG test is 24 hours.

12.15.6 Every 20-h, conduct the oil sampling and oil leveling according to 12.5 and 12.6. See Fig. A10.1. Record the time when the final (100-h) leveling is completed; be aware that most of the engine disassembly must be completed within 12 h of this time. See 13.2.1.

12.16 Test Termination-Terminate the test as follows:

12.16.3 Terminate the test at the completion of the 100-h engine oil quality testing, following the taking of the purge and analysis samples and completion of the end of test oil leveling procedure. Record the end of test time after the final engine oil level procedure.

12.16.3.1 Drain the oil sump into a suitable container and retain for future analysis.

12.16.3.2 Drain the condenser cooling system.

12.16.3.3 Drain the engine coolant.

12.16.3.4 Remove the engine from the test stand, and transport it to the engine disassembly area for determination of test results.

13. Determination of Test Results-

13.1 This section describes techniques used to evaluate the oils performance with respect to oxidation (viscosity increase), wear (camshaft and lifter), piston deposits, ring sticking, and oil consumption.

13.2 Engine Disassembly-Disassemble the engine according to the following instructions, in preparation for inspection, rating, and measurement:

13.2.1 Plan the disassembly so that the parts to be rated for sticking, deposits, and plugging (pistons and rings) shall be removed from the engine within 12 hours of the completion of the oil level.

13.2.2 Remove the components from the top of the engine in order to gain access to the cylinder bores.

13.2.3 Remove the carbon deposits from the top portion of the cylinder walls, above the top compression ring travel, before removing the pistons from the engine.

13.2.4 Disassemble the remainder of the engine.

13.3 Preparation of Parts for Rating of Sticking, Deposits, and Plugging-Prepare the specified parts for rating according to the following instructions:

13.3.1 Check all piston rings for freedom of action in the grooves as the pistons are removed from the engine.

13.3.1.1 Determine which rings are hot-stuck or cold-stuck (see Section 3 for definitions of hot-stuck and cold-stuck rings) and record the piston number and ring identification (for example, piston No. 3, top ring) for such rings on Form 8, Summary of Oil Ring Land Deposit Rating, in standardized report form set (See Annex A6). Record the total number of hot-stuck rings on Form 4, Test Result Summary, in the standardized report form set (See Annex A6).

13.3.2 At time of disassembly, remove all piston rings that are free. Leave any stuck rings (includes pinched rings; see 3.2.9) in place. Any piston groove that cannot be rated, due to the presence of a stuck ring, shall be rated as having 100% heavy carbon in the groove.

13.3.3 If the piston deposits cannot be rated immediately after the pistons are removed from the engine, store the pistons

in a desiccator for no longer than 72 h from end of test before rating. Do not wipe the pistons before storing them. See 13.7.

13.4 Piston deposit ratings - The pistons are rated for piston skirt varnish as well as deposits on the ring lands, undercrown area, and in the ring grooves.

13.4.1 Establish the proper environment for parts rating (see section xxx). Rate all parts against a white background.

13.4.1.1 Gently wipe off any excess oil from the piston skirts with a soft cloth.

13.4.1.2 Do not apply any chemicals or build-up oil to the pistons prior to rating them for deposits.

13.4.2 Rate each piston top groove, 2nd groove, oil ring groove, 2nd land, and undercrown area (where the horizontal and vertical planes meet) for deposits using CRC Manual No. 20+ rating techniques and breakdown methods. Carbon deposit ratings will consist of only two levels: Heavy (0.00 merit value) or Light (0.75 merit value). These ratings shall be performed in a rating booth, using a 20-segment piston rating cap, a piston rating stand, and a 22W circular rating lamp.

13.4.2.1 The undercrown area to be rated is defined as the area on the undercrown area of the piston that resembles a common adhesive bandage.

13.4.2.2 Rate only the deposits present. Though chipped areas might sometimes appear, rate what appears and do not interpolate deposits.

13.4.2.3 Report any unusual deposits observed in the comments section of Summary of Piston Deposits in standardized report form set (See Annex A6).

13.4.3 If multiple ratings are deemed necessary of a given part or parts, consensus rating may be used according to the following:

13.4.3.1 The raters shall be from the laboratory in question, no outside raters can be used unless requested and directed through the Sequence IIIG Surveillance Panel.

13.4.3.2 No averaging of ratings is permitted.

13.4.3.3 Only one rating value is to be reported and is to be agreed to by the raters involved.

13.4.4 Average each individual piston (thrust side and anti-thrust side) for inclusion in Weighted Piston Deposit (WPD) results.

13.4.5 Calculate the average of the six oil ring land (land 3) ratings and record this as the average oil ring land deposits on Form 8, Summary of Oil Ring Land Deposit Rating, and on Form 4, Test Results Summary, in standardized report form set (See Annex A6).

13.4.6 Weighted Piston Deposit Rating (WPD) - This weighted piston rating is comprised of skirt varnish, top groove, 2nd groove, oil ring groove, undercrown, 2nd land, and 3rd land.

13.4.6.1 The Weighted Piston Deposit (WPD) result for each individual piston is calculated using the following weighting factors:

Piston Undercrown	10%
2nd Land	15%
3rd Land (ORLD)	30%
Piston Skirts (APV)	10%
Top Groove	5%
2nd Groove	10%
Oil Ring Groove	20%

13.4.6.2 Calculate the Weighted Piston Deposit result for each piston by multiplying the rated result for each piston part by the weighting factor in 13.4.6.1 (in decimal form) to determine a weighted rating for that piston part. The Weighted Piston Deposit result is the sum of the weighted ratings for the individual piston parts.

13.4.6.3 The Weighted Piston Deposit (WPD) result for the test is calculated by a simple average of the six individual piston WPD ratings.

13.5 Post-Test Camshaft and Lifter Wear Measurements-Measure the wear of the camshaft lobes and lifters to the nearest 0.001 mm (0.00004 in.) Refer to Practice E 29 for any needed rounding; use the rounding-off method. Proceed according to the following procedure:

13.5.1 Clean the camshaft lobes and lifters with ~~aliphatic naphtha~~ mineral spirits (Warning-see Note 76); blow dry them with clean, dry shop air. (Warning-see Note 77.)

Note 76: Warning-Combustible. Health Hazard.

Note 77: Warning-For technical use only.

13.5.2 Store the camshaft and lifters in a temperature-controlled room for at least 90 min before making dimensional measurements, to ensure temperature stabilization. The temperature of the post-test measurement room must be within 3°C (5°F) of the temperature of the pre-test measurement room.

13.5.3 The camshaft measurement shall be made using a Mitutoyo Snap Gauge, model 201-152, and a Mitutoyo Digital Indicator, model 543-252B, to measure the camshaft lobes. The lifter measurements shall be made using a digital indicator, equipped with a Mitutoyo 4.3mm flat point, model 131-259, mounted in a dial indicator stand. The dial indicator stand shall be equipped with a V-block that is rigidly mounted to the base and locates the lifter with its center axis in line with the digital indicator.

13.5.3.1 Use dimensional measuring equipment accurate to 0.001mm. Before each measurement session, use standards traceable to the National Institute of Standards and Technology, to ensure measuring equipment accuracy. Include standards having length values within 1.3 mm (0.05 in.) of the typical lifter and lobe measurements taken. Use the same equipment and standards for post-test measuring as were used for pre-test measuring. If a calibration shift between pre-test and post-test measurements is detected, evaluate the shift to determine its effect on the wear measurements. Record the results of the evaluation, and any corrective action taken.

13.5.4 Measurements on a camshaft and the lifters used in a given test must be made by the same person if the measurement equipment utilized is operator-sensitive (that is, if a micrometer is used with which the operator determines the spindle pressure).

13.5.5 When measuring the camshaft and the lifters, take precautions to prevent any influence of body heat on the measurements.

13.5.6 Measure the maximum dimension of each camshaft lobe, transverse to the camshaft axis. This dimension is at the rear edge of all lobes (lobes are numbered from the front to the rear of the camshaft).

13.5.7 Measure the length of the lifters at the center of the lifter foot.

13.5.8 Calculate the wear for each camshaft lobe and lifter by subtracting the after-test measurement from the before-test measurement.

13.5.8.1 Due to varnish accumulations on camshaft lobes of high wear resistant oils, post-test measurements may indicate a larger numeric value than pre-test measurements. In this situation, the end of test calculation equates to a negative value. All negative values shall be overridden and entered as "0.000 mm" wear for all calculations when determining post-test results.

13.5.9 Calculate the cam-plus-lifter wear by adding the values obtained in 13.5.8. Record the results on Form 7, Valve Lifter and Camshaft Wear Results, in standardized report form set (See Annex A6).

13.5.10 Determine the maximum, minimum, and average camshaft-lobe, valve-lifter, and cam-plus-lifter wear. Record the values on Form 7, Valve Lifter and Camshaft Wear Results, in standardized report form set (See A6).

13.6 End-of-Test Used Oil Sample Testing -Conduct a Cold-Cranking Simulator test (Test Method D5293) and a Mini Rotary Viscometer test (Test Method D4684) on the end-of-test (EOT) used oil sample with the exceptions that follow.

13.6.1 For non reference oils run a Cold-Cranking Simulator (CCS) test (Test Method D5293) on the end-of-test (100 hour) analysis sample at the temperature specified for the test oils given viscosity grade in Table 1 of SAE J300^{zz} Revised DEC1999. Report results on Form 6, Used Oil Analysis Results, in the standardized report form set (See A6).

^{zz} SAE J300, Engine Oil Viscosity Classification, December 1999. (Footnote will be given an appropriate number when this section is incorporated into the Sequence IIIG Test Method.)

13.6.2 Run the Mini Rotary Viscometer test (Test Method D4684), MRV-TP1 at grade using the SAE J300 specifications, if a passing CCS result is obtained at grade. If the CCS fails run the MRV at the same temperature as the CCS (one grade higher based on the J300). Report the end-of-test Mini Rotary Viscometer test results as MRV Temperature in °C as follows. If a Yield Stress is obtained at the designated temperature report the Yield Stress in Pa and note the Apparent Viscosity as not measured (NM). If a Yield Stress is not obtained at the designated temperature, report the Yield Stress as not measured (NM) and record the Apparent Viscosity in cP. Report the results on Form 6, Used Oil Analysis Results, in the standardized report form set (See A6).

13.6.3 If the % Viscosity Increase for the kinematic viscosity at EOT is higher than (IIIG limit specified) TBD %, the CCS and MRV

tests are not required. A notation is required in the Other Comments & Outlier section of Form 13 (See A6) indicating that the CCS and MRV were not run and enter not measured (NM) in the standardized report form set (See A6).

13.6.4 If the test oil is a straight-grade oil, the Cold- Cranking Simulator and Mini -Rotary Viscometer tests are not required. A notation is required in the Other Comments & Outlier section of Form 13 (See A6) indicating that the CCS and MRV were not run and enter not measured (NM) in the standardized report form set (See A6).

13.7 Viscosity Test-Determine the viscosity of a sample of the fresh test oil and of the ~~nine~~ ~~six~~ test samples by analysis according to the following instructions:

13.7.1 Do not filter the samples.

13.7.2 Use Test Method D 445.

13.7.3 Use either the Cannon-Fenske Routine Viscometer of the Ostwald Type for Transparent Liquids, or the Cannon-Fenske Opaque Viscometer of the Reverse-Flow Type for Transparent and Opaque Liquids.

13.7.4 Conduct the measurement at 40°C (104°F).

13.7.5 Record the results on Fig. A6.4

13.7.6 Critically examine the relationship of the viscosity of the initial oil sample to that of the new oil. The viscosity of the initial sample can legitimately be as much as 10 cSt less than that of the new oil, because of permanent shearing effects. If the difference is greater than 10 cSt, explore possible causes such as failure to purge the oil sample line [removing the ~~473472~~-mL (16-oz) purge sample] prior to withdrawing the 237-mL (8-oz) analysis sample, or an excessive amount of build-up oil in the system.

13.7.7 Calculate the change in viscosity in centistokes, from the value for the initial sample, for the last five samples. Record the changes on Form 6, Used Oil Analysis Results, in standardized report form set (See Annex A6). Record the final percent viscosity increase on Form 4, Test Result Summary, in standardized report form set (See Annex A6).

13.7.8 Calculation instructions for special cases related to % Viscosity Increase

13.7.8.1 Instructions for calculating and reporting results if the Final Original Units Result on Form 4 (See A6) for % Viscosity Increase is zero or negative.

13.7.8.2 The minimum result considered for the % Viscosity Increase will be 0.1%. Substitute 0.1 for the original unit result and complete the calculations on form 4 (See A6). A notation is required in the Other Comments & Outliers section of Form 13 (See A6) indicating that the Original Units Result has been modified for a special case.

13.7.8.3 Instructions for calculating and reporting results if the Viscosity Result on Form 6 (See A6) for Viscosity Increase Data is Too Viscous to Measure (TVTM).

13.7.8.4 The maximum kinematic viscosity result reported will be 8000 cSt using either equipment noted in 13.7.3, use a tube size of 500 or less. If the measured viscosity is 8000 cSt using tube size 500, this will be considered the maximum reportable viscosity. Report 8000 cSt on Form 6 (See A6) for entry in the column listed as Viscosity. This value will be used to do the calculations for Change and Percent. (This will provide consistent TVTM data for reporting purposes and it also expands the maximum viscosity to fill the space allowed by the data dictionary.)

13.7.8.5 Complete the calculations on Form 4 (See A6) for % Viscosity Increase using the Percent Value for the final drain from Form 6 except that the Severity Adjustment (SA) displayed and used for % Viscosity Increase calculations will be set to zero (0). A notation is required in the Other Comments & Outliers section of Form 13 (See A6) indicating that the Severity Adjustment has been modified for a special case.

13.8 Testing Oil Samples for Wear Metals - Perform Inductively Coupled Plasma Optical Emission Spectrometry (ICP) Analysis on the initial and all 20h oil samples for iron copper and lead in the oil. Report the results of the ICP Analysis on these three metals on Form 6 (See A6).

13.9 Blowby Flow Rate Measurements-Plot blowby flow rate measurements on Form 10, Blowby Results & Plot, in standardized report form set (See Annex A6).

13.10 Oil Consumption Computation-Compute the oil consumption for the test as follows:

13.10.1 See Figure A10.1 for the oil consumption calculation equation.

13.10.2 Determine the total fresh oil added to the engine, ~~during~~ ~~after~~ the initial oil leveling run, for each of the ~~and~~ 20-h test periods in Fig. A10.1. Enter the total in the end-of-test total column in Fig. A10.1. ~~in position "a."~~

13.10.3 Determine the total amount of oil discarded during ~~each of the~~ ~~100-h~~ 20-h test periods in ~~of~~ Fig. A10.1. Enter the total in the end-of-test total column on Fig. A10.1. ~~in position "b."~~

13.10.4 Determine the computed oil level in milliliters at the end of the test, in Fig. A10.1. Enter the number in the end-of-test total column on Fig. A10.1. ~~in position "c."~~

13.10.5 Add the values determined in 13.10.2 and 13.10.4, and subtract the value determined in 13.10.3. Subtract 236 ml (the final oil sample which is not replaced with new oil) from the value computed above and enter the remainder, which is the amount of oil consumed in the test, in the blank for total oil consumption in the Fig. A10.1.

13.10.6 For non-reference oils, evaluate the oil consumption result based upon the following guidelines:

13.10.6.1 For oils with a stated Noack volatility that is nominally 15% or less, the test results are considered non-interpretable for purposes of MTAC if the oil consumption exceeds 5.2L.

13.10.6.2 For oils with a stated Noack volatility that ~~is~~ exceeds 15%, the test results are considered non-interpretable for purposes of MTAC if the oil consumption exceeds 6.5L.

13.11 Photographs of Test Parts—Take color photographs of the test parts for inclusion in the test report, as follows:

13.11.1 Photograph pistons after all ratings have been completed.

13.11.2 Do not coat the pistons with build-up oil (for preservation) before the photographs are taken. Do not re-install piston rings.

13.11.3 Photograph all six piston thrust sides in one shot. No piston labels required. (see 13.11.13)

13.11.4 Photograph all six piston anti-thrust sides in one shot. No piston labels required. (see 13.11.13)

13.11.11 Size the final piston photographs for inclusion in the test report so that the overall piston height is not less than 5 cm (2 in.), but small enough that three photographs can be mounted in a column on the 28-cm (11-in.) dimension of a 22 by 28-cm (8 1/2 by 11 in.) sheet of paper.

13.11.12 Assemble the photographs on two pages, with the thrust side photographs on one page, and the anti-thrust photographs on the other page.

13.11.13 Mount the photographs on each of the two pages with the reciprocating axes of the pistons parallel to the 28-cm (11-in.) dimension of the page. Arrange the photographs in two vertical columns of three each, with the No. 1 piston in the upper left corner of the page, No. 2 piston in the upper right corner, No. 3 piston in the center of the left column, etc.

13.12 Retention of Representative Test Parts-Retain for at least 6 months all camshafts and lifters.

13.13 Severity Adjustments-Calculate severity adjustments (SA) for results of non-reference engine oil tests. Use the control chart technique, described in A5, for determining the laboratory bias for % viscosity increase, piston skirt varnish, and weighted piston deposits. Enter the adjustments on Form 4, Test Result Summary, in standardized report form set (See A6).

13.14 Determination of Operational Validity-Determine and document the operational validity of every Sequence IIIG test conducted, according to the following:

13.14.1 Complete the report forms to substantiate that the test stand, engine build-up, installation of the engine on the test stand, and the test operation conformed to the procedures specified in this test method.

13.14.2 Inspect the test records for instances of downtime (excluding the initial oil level run of the test), and record any such instances on Form 13, Downtime & Outlier Report Form, in standardized report form set (See A6). Enter the total downtime on Form 13, Downtime & Outlier Report Form, in standardized report form set (See A6). If the total downtime exceeds 24 h, note on Form 1, in standardized report form set (See A6) that the test is invalid.

13.14.3 *Sequence IIIG tests must average higher than 23 l/m (0.812 cu.ft./m) blowby rate for hours 1 through 26 in order to be considered a valid engine build. {The Sequence IIIG blowby limits have not been set at this time. These limits will be set based upon data generated in the GF-4 Matrix.}*

13.14.4 If the end of test quality index value is below 0.000, conduct an engineering review of the test operations. The engineering review will be conducted by the test laboratory, and, for reference oil tests, the Test Monitoring Center. If needed, additional industry experts may be consulted. Document the results of the engineering review.

14. Report

14.1 Report Forms-Use the standardized report form set and data dictionary for reporting the test results for test oils and reference oils, and for summarizing the operational data.

14.2 Use of SI Units-Report all results in metric (SI) units. Record all measurements, with the exception of top and bottom ring gaps, in SI units.

14.3 Precision of Reported Units-Use Practice E 29 for rounding off data; use the rounding-off method. Report the data to the same precision as indicated in Annex A9.

14.4 Deviations from Test Operational Limits-*In addition to any deviations specified in 13.13, report all deviations from the specified test operational limits on a supplemental page. Include the test time, magnitude, and duration of the deviations. Include deviations from specified warm-up times, scheduled and unscheduled shutdowns, and shutdown procedures.*

15. Precision and Bias

15.1 Test precision is established on the basis of reference oil test results (for operationally-valid tests) monitored by the ASTM TMC. The data are reviewed semi-annually by the Sequence IIIG Surveillance Panel. Contact the ASTM TMC for current industry data.

15.1.1 Intermediate Precision (ip) (formerly called repeatability)- is the difference between two results obtained on the same test oil in the same laboratory and would, in the long run, in the normal and correct conduct of the test method, exceed the values shown in Table 12 in only one case in twenty. It should be noted that these repeat tests are not run in the same engines; that each engine is completely rebuilt before each test, and the engine is believed to be an important variable affecting the precision of the test.

15.1.2 Reproducibility (R)-The difference between two single and independent results obtained on the same oil by different operators working in different laboratories and would, in the long run, in the normal and correct conduct of the test method, exceed the values in Table 12 only one case in twenty.

15.1.3 Bias will be determined by applying an accepted statistical technique to reference oil test results, and when a significant bias is determined, a severity adjustment will be permitted for non-reference oil test results

16. Keywords

16.1 and lifter wear; deposits; engine oil; engine wear; high-temperature performance; oil consumption; oil thickening; oil viscosity; oxidation resistance; Sequence IIIG test; spark-ignition automotive engine; varnish; varnish deposition

ANNEXES

(Mandatory Information)

A1. THE ROLE OF THE ASTM TEST MONITORING CENTER AND THE CALIBRATION PROGRAM

A1.1 Nature and Functions of the ASTM Test Monitoring Center (TMC)-The ASTM TMC is a non-profit organization located in Pittsburgh, PA and is staffed to administer engineering studies; conduct laboratory visits; perform statistical analyses of reference oil test data; blend, store, and ship reference oils; and provide the associated administrative functions to maintain the referencing calibration program for various lubricant tests as directed by Subcommittee D02.B and the Test Monitoring Board. The TMC coordinates its activities with the test sponsors, the test developers, the surveillance panels, and the testing laboratories.

A1.2 Rules of Operation of the ASTM TMC-The TMC operates in accordance with the ASTM Charter, the ASTM Bylaws, the Regulations Governing ASTM Technical Committees, the Bylaws Governing ASTM Committee D-2, and the Rules and Regulations Governing the ASTM Test Monitoring System.

A1.3 Management of the ASTM TMC-The management of the Test Monitoring System is vested in the Test Monitoring Board (TMB) elected by Subcommittee D02.B. The TMB selects the TMC Administrator who is responsible for directing the activities of the TMC staff.

A1.4 Operating Income of the ASTM TMC-The TMC operating income is obtained from fees levied on the reference oils supplied and on the calibration tests conducted. Fee schedules are established and reviewed by Subcommittee D02.B.

A1.5 Conducting a Reference Oil Test:

A1.5.1 For those laboratories which choose to utilize the services of the ASTM TMC in maintaining calibration of test stands, full-scale calibration testing shall be conducted at regular intervals. These full-scale tests are conducted using coded reference oils supplied by the ASTM TMC. It is a laboratory's responsibility to maintain the calibration in accordance with the test procedure. It is also a laboratory's responsibility to keep the on-site reference oil inventory at or above the minimum level specified by the TMC test engineers.

A1.5.2 When laboratory personnel decide to run a reference calibration test, they shall request an oil code from the cognizant TMC engineer. Upon completion of the reference oil test,

the data shall be sent in summary form (use TMC-acceptable forms) to the TMC by telephone facsimile transmission, or by some other method acceptable to the TMC. The TMC will review the data and contact the laboratory engineer to report the laboratory's calibration status. All reference oil tests, whether aborted, invalidated, or successfully completed, shall be reported to the TMC. Subsequent to sending the data in summary form to the TMC, the laboratory is required to submit to the TMC the written test report specified in the test procedure.

A1.6 New Laboratories-Laboratories wishing to become a part of the ASTM Test Monitoring System will be requested to conduct reference oil tests to ensure that the laboratory is using the proper testing techniques. Information concerning fees, laboratory inspection, reagents, testing practices, appropriate committee membership, and rater training can be obtained by contacting the TMC Administrator at ASTM Test Monitoring Center, 6555 Penn Ave. Pittsburgh, PA 15206.

A1.7 Introducing New Sequence IIIG Reference Oils-The calibrating reference oils produce various wear, oil thickening, and deposit characteristics. When new reference oils are selected, member laboratories will be requested to conduct their share of tests to enable the TMC to establish the proper industry average and test acceptance limits. The ASTM D02.B0.01 Sequence IIIG Surveillance Panel requires a minimum of four tests to be conducted prior to establishing the industry average and test acceptance targets for new reference oils. The TMC estimates that laboratories will normally be requested to run no more than one contributing test per year per test stand.

A1.8 TMC Information Letters:

A1.8.1 Occasionally, it is necessary to change the procedure, and notify the test laboratories of the change, prior to consideration of the change by either ASTM Subcommittee D02.B on Automotive Lubricants or ASTM Committee D-2 on Petroleum Products and Lubricants. In such a case, the TMC will issue an Information Letter. Subsequently, prior to each semi-annual Committee D-2 meeting, the accumulated Information Letters are balloted by ASTM Subcommittee D02.B. The ballot is reviewed at the ASTM Subcommittee D02.B meeting, and the actions taken are considered at a meeting of ASTM Committee D-2. By this means, the Society due process procedures are applied to these Information Letters.

A1.8.2 The review of an Information Letter prior to its original issue will differ according to its nature. In the case of an Information Letter concerning a part number change which does not affect test results, the TMC is authorized to issue such a letter. Long-term studies by the surveillance panel to improve the

test procedure through improved operation and hardware control may result in a recommendation to issue an Information Letter. If obvious procedural items affecting test results need immediate attention, the test sponsor and the TMC will issue an Information Letter and present the background and data to the surveillance panel for approval prior to the semi-annual ASTM Subcommittee D02.B meeting.

A1.8.3 Authority for the issuance of Information Letters was given by the ASTM Committee on Technical Committee Operations (COTCO) in 1984, as follows:

``COTCO recognizes that D-2 has a unique and complex situation. The use of Information Letters is approved providing each letter contains a disclaimer to the effect that such has not obtained ASTM consensus. These Information Letters should be moved to such consensus as rapidly as possible."`

A1.8.4 Information Letters appertaining to this procedure issued prior to 2002-03-15 are incorporated in this test method. A listing of such Information Letters, and copies of the letters, may be obtained from the TMC. Information Letters issued subsequent to this date may also be obtained from the TMC.

A1.9 TMC Memoranda-In addition to the aforementioned Information Letters, supplementary memoranda are issued. These are developed by the TMC, and distributed to the Sequence IIIG Test Surveillance Panel and to participating laboratories. They convey such information as batch approvals for test parts or materials, clarification of the test procedure, notes and suggestions for the collection and analysis of special data that the TMC may request, or for any other pertinent matters having no direct effect on the test performance, results, or precision and bias.

A1.10 Precision Data-The TMC determines the current Sequence IIIG test precision by analyzing results of calibration tests conducted on reference oils. Current precision data can be obtained from the TMC.

A2. Sequence IIIG Test Parts Replacement Guidelines

A2.1 Tables A2.1 an A2.2 list ~~which~~ parts which shall be replaced every test and as necessary, respectively. If a part cannot be found in the following tables, it should be replaced every test.

Table A2.1 Parts to be replaced every test.

PART DESCRIPTION	PART NUMBER
Arm, Rocker with Pivot Bearing	OHT3F-058-1
BEARING, KIT, ENGINE	OHT3F-042-2
Bolt, Camshaft Sprocket	24501366
Bolt, Cylinder Head, Long	25527831
Bolt, Cylinder Head, Short	25533811
Bolt, Flywheel	24505092
Bolt, Rear Cover Housing	24503970
Bolt, Rocker Arm, Special Test	3F-058-02
Camshaft, Special Test, phosphate-coated	OHT3F-008-8
Cap, Valve Spring Retainer	24502257
Chain, Timing	24504668
Clip, Retainer, Piston Pin	OHT3F-012-1
COOLER, OIL, NICKEL PLATED, BYPASS CLOSED	OHT3F-030-2
Damper, Timing Chain (includes bolt, retaining ring)	24503893
FILTER, OIL	TBD
Gasket kit, Intake Manifold lower	12480830
Gasket kit, Intake Manifold Upper	17113137
Gasket, Cylinder Head, left	24503802
Gasket, Cylinder Head, right	24503801
Gasket, Front Cover	24502252
Gasket, Oil Filter Adapter	25534742
Gasket, Oil Pan	12574776
Gasket, Oil Suction Tube	24501259
Gasket, Rear Cover Housing	24507388
Gasket, Rocker Cover	25532619
Gasket, Water Outlet	24502433
Gasket, Water Pump	24501565
Head, Cylinder	24502260
Key, Camshaft Sprocket	24500618
Key, Valve Stem Keeper	1016634
Lifter, Test ACI w/Flat (25338738A)	OHT3F-029-3
PIN, PISTON WRIST, PKG. OF 6	OHT3F-014-1
PISTON, TEST, RUNS 1 & 2, GRADE 12	OHT3F-053-1
PISTON, TEST, RUNS 3 & 4, GRADE 34	OHT3F-054-1
PISTON, TEST, RUNS 5 & 6, GRADE 56	OHT3F-055-1
PLATE, CAMSHAFT THRUST, .1520" THICKNESS	OHT3F-011-2
Plug, Engine Block Core Hole	24500867
Plug, Cylinder Head Core Hole	3835577
Plug, Cylinder Head Cup	24502262
Plug, Engine Block, Oil Gallery	3835577

Plug, Ignition Spark	NGK TR6
Plunger, Oil Relief	25530949
PUSHROD, SPECIAL LENGTH, PKG. OF 12	OHT3F-007-1
RETAINER CLIP, PISTON PIN PKG. OF 12	OHT3F-012-1
RING, PISTON, RUN 1, ENGINE SET	OHT3G-050-RUN1
RING, PISTON, RUN 2, ENGINE SET	OHT3G-050-RUN2
RING, PISTON, RUN 3, ENGINE SET	OHT3G-051-RUN3
RING, PISTON, RUN 4, ENGINE SET	OHT3G-051-RUN4
RING, PISTON, RUN 5, ENGINE SET	OHT3G-052-RUN5
RING, PISTON, RUN 6, ENGINE SET	OHT3G-052-RUN6
ROCKER ARM ASSEMBLY (Includes: 3F058-02)	OHT3F-058-1
Rod, Connecting	24501696
Seal, Crankshaft Front Oil (Lip Seal)	24504098
Seal, Crankshaft Rear Oil (Lip seal)	25534760
SEAL, EXHAUST VALVE STEM	OHT3F-061-1
SEAL, INTAKE VALVE STEM	OHT3F-060-1
Spring, Oil Relief Valve	1262505
SPRING, VALVE Special Test (COLOR CODE PINK)	OHT3G-059-1
Sprocket, Camshaft	24505306
Valve, Exhaust (STD)	24507423
Valve, Intake (STD)	12569550

Table A2.1 Parts to be Replaced Every Test (2 pages)

Table A2.2 Parts to be Replaced As Needed (3 pages)

PART DESCRIPTION	PART NUMBER
ADAPTER, BLOWBY BREATHER TUBE	OHT3F-040-1
ADAPTER, OIL FILTER	OHT3F-035-1
Adapter, Oil Filter Engine W / External Bypass Valve	OHT3F-080-1
Adapter, Throttle Body, Air Inlet	OHT3F-001-2
Balancer, Harmonic (24507058 or 12563265)-(1997 - 2003)	12563265
Bearing, Balance Shaft Front (part of 24502388)	SKF6205-2ZNRJEM
Block, Engine Assembly	24506028
Bolt / Screw, Thrust Plate retainer	25519242
Bolt, Connecting Rod	25531956
Bolt, Counter Balance Gear	24501367
Bolt, Counter Balance Shaft retainer	24500055
Bolt, Harmonic Balancer (24506341 or 24504736) (1997 - 2003)	24504736
Bolt, Main Cap	24503056
Bolt, Main Cap, Side	24505576
Bolt, Oil Filter Adapter	24504713
Bolt, Oil Pan (24502791 or 24508626) (1997 - 2003)	24508626
Bolt, Oil Suction Tube	24505570
Bolt, Rocker Cover W / Washer (25534748 or 24502164) (1997 - 2003)	24502164
Bolt, Screw Camshaft Sensor	25526395
Bolt, Screw, Oil Gearotor, Cover	25519242
Bolt, Stud Type, Front Cover & Crankshaft Sensor (Short)	24504717
Bolt, Stud Type, Front Cover & Crankshaft Sensor (Long)	24504718
Bolt, Upper Intake Long	24505205
Bolt, Upper Intake Short	24506498
Bolt, Upper Intake, Stud	24502453
BRACKET, BREATHER TUBE	OHT3F-041-1
BREATHER TUBE, S.S. MATERIAL	OHT3F-075-1
Bushing, Balance Shaft Rear	24503193
BUSHING, ROCKER COVER	OHT3F-028-1
CONNECTOR, MODIFIED FOR LENGTH, GM PN 24502883	OHT3F-039-2
Cover, Engine Front	OHT3F-085-1
Cover, Oil Gearotor	25521935
Cover, Rocker Arm Valve Cover Left Side Plastic	25534753
Crankshaft	34502168
DIP STICK, METRIC, EXTENDED LENGTH	OHT3F-064-1
FILTER, OIL, PRO-TEC	OHT3G-057-3
FITTING, OIL FILTER ADAPTER	OHT3F-043-1
FLYWHEEL, MANUAL, MODIFIED P.N. 24503285	OHT3F-020-2
GASKET, EXHAUST, END PLATE	OHT3F-009-1
GASKET, EXHAUST, FLANGE, METAL	OHT3F-018-1
Gasket, Manifold, Upper Intake	17113137
GASKET, OIL COOLER, PKG. OF 50	OHT3F-074-1
GASKET, OIL FILTER, PKG. OF 50	OHT3F-062-1
Gear, Balanceshaft Drive	24504792
Gear, Balanceshaft Driven	24503524

Grommet, Rocker Arm Valve cover bolt	25534749
HARNESS, COIL PACK SEGMENT	3F022-2
HARNESS, FUEL INJECTOR SEGMENT	3F022-1
HARNESS, WIRING, DYNO W/ OHT3F-056-1 SENSOR	OHT3F-022-1
Injector, Fuel	17120601
Key, Crankshaft (25534912 or 12563282) (1997 - 2003)	12563282
Magnet, Camshaft Position Sensor	10456195
MANIFOLD, CAST IRON	OHT3F-003-0
MANIFOLD, EXHAUST, WATER COOLED ASSY (ONE BANK)	OHT3F-003-1
<u>ASSEMBLY INCLUDES:</u>	
1 EA. RUNNER, EXHAUST MANIFOLD	OHT3F-004-1
1 EA. PLATE, REAR, EXHAUST MANIFOLD	OHT3F-005-1
1 EA. ELBOW, EXHAUST, MODIFIED	OHT3F-005A-1
1 EA. PLATE, FRONT, EXHAUST MANIFOLD	OHT3F-006-1
2 EA. GASKET, EXHAUST, END PLATE	OHT3F-009-1
1 EA. GASKET, EXHAUST, FLANGE, METAL	OHT3F-018-1
Manifold, Lower Intake	24505728
Manifold, Upper Intake	17096162
METER, BLOWBY	RX-116169-A1 REV N
Module, Assembly, Coil Pack	1103948
MOUNT FRONT ENGINE W/ BOLT PATTERN FOR COIL PACK	OHT3F-026-1
MOUNT, REAR ENGINE HOUSING W/ AIR STARTER, MUFFLER & SHIM PACK	OHT3F-025-1
<u>ASSEMBLY INCLUDES:</u>	
STARTER, AIR	3F025-03
MUFFLER, STARTER, AIR	3F025-04
SHIM PACK, STARTER, AIR	3F025-05
MUFFLER, STARTER, AIR	3F025-04
Nut, Throttle Body Fuel Rail Retainer	24506469
Nut, Throttle body Retainer	24506469
OUTLET, COOLANT	OHT3F-034-1
PAN, IIF TEST, NICKEL PLATED	OHT3F-073-1
PCM, SPECIAL	OHT3F-021-1
PCV, DUMMY	OHT3F-002-1
Pin, Cylinder Head Locating	25536320
Pin, Front Cover Lower	25536323
Pin, Front Cover Upper	24501162
Pin, Transmission Locating	12338076
PLATE, EGR BLOCKOFF	OHT3F-024-1
PLATE, FRONT, EXHAUST MANIFOLD	OHT3F-006-1
PLATE, REAR, EXHAUST MANIFOLD	OHT3F-005-1
PLATE, WATER PUMP HOUSING	OHT3F-031-1
Plug, Auto Hex, Socket, (Main Oil Gallery Block Off)	444777
PLUG, DIP STICK	OHT3F-065-1
PLUG, DRAIN, MODIFIED	OHT3F-063-1
Pump, Oil, Gearoter Set	24505433
Rail, Fuel	17113198
Rail, Fuel Injector	17120601

REAMER, DIP STICK AND DIP STICK HOLE PLUG	OHT3F-071-1
Regulator, Fuel Pressure, on Rail	17113346
Retainer, Counter Balance, Timing Chain Oiler	24500374
RUNNER, EXHAUST MANIFOLD	OHT3F-004-1
Screen, Oil pump (w/suction pipe) MUST USE THIS PART	24505569
Seal, oil pan drain plug (o ring)	3536966
Sensor, Camshaft Position	10456148
Sensor, Mass Air Flow (2003 Shielded)	12568877
SENSOR, MODIFIED COOLANT TEMPERATURE	OHT3F-056-1
Shaft Assembly, Counter Balance	24502388
Shield, Crankshaft Position Sensor	24506440
SHIM PACK, STARTER, AIR	3F025-05
SHIM, STEEL, .005" THICK, 10 PER PKG.	OHT3F-072-005
SHIM, STEEL, .010" THICK, 10 PER PKG.	OHT3F-072-010
SHIM, STEEL, .015" THICK, 10 PER PKG.	OHT3F-072-015
SHIM, STEEL, .020" THICK, 10 PER PKG.	OHT3F-072-020
SHIM, STEEL, .031" THICK, 10 PER PKG.	OHT3F-072-031
SLEEVE, VALVE STEM PROTECTORS (PKG. OF 100)	OHT3F-070-1
SPROCKET, CRANKSHAFT, SPECIAL 2 PC	OHT3F-036-1
STARTER, AIR	3F025-03
Throttle Body (2 Bolt Mass Air Flow Sensor)	24507235
TOOL, CAMSHAFT BUSHING INSTALLATION	OHT3F-019-2
TOOL, OIL PUMP PRIMER	OHT3F-038-1

Table A2.2 Parts to be Replaced As Needed (3 pages)

A3. Sequence IIIG Engine Oil Dipstick Calibration Curve

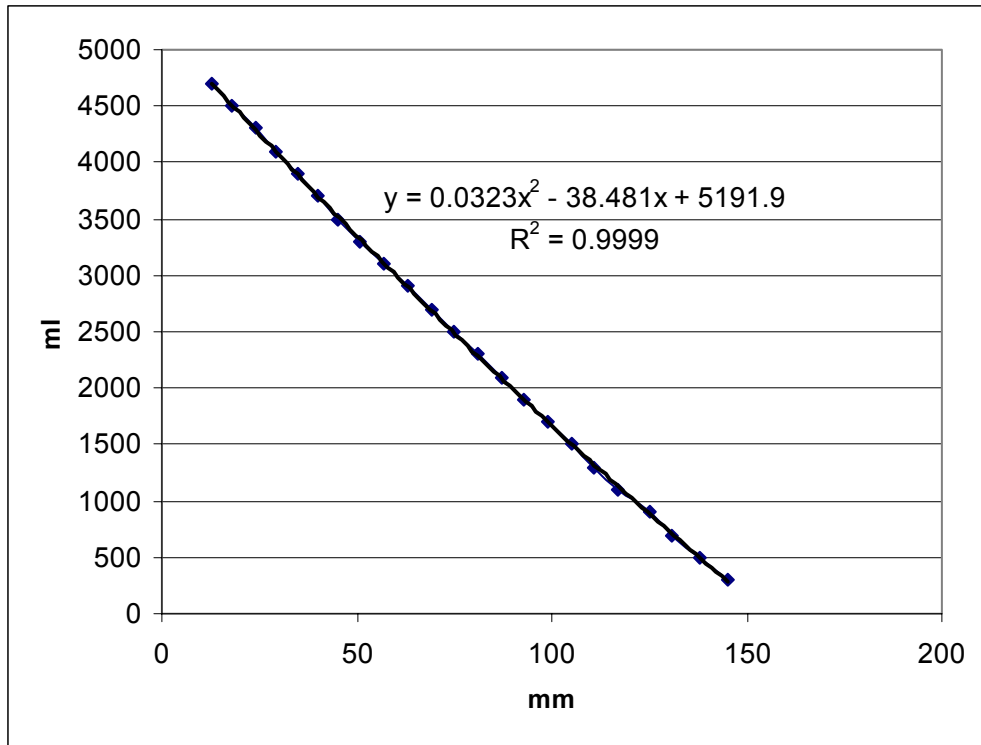

Calibration for IIIG Oil Pan using OHT3G-064-1 extended length dipstick

MM	ML
1	5153
2	5115
3	5077
4	5038
5	5000
6	4962
7	4924
8	4886
9	4848
10	4810
11	4773
12	4735
13	4697
14	4659
15	4622
16	4584
17	4547
18	4510
19	4472
20	4435
21	4398
22	4361
23	4324
24	4287
25	4250
26	4213
27	4176
28	4140
29	4103
30	4067
31	4030
32	3994
33	3957
34	3921
35	3885
36	3848
37	3812
38	3776
39	3740
40	3704
41	3668
42	3633
43	3597
44	3561
45	3526
46	3490
47	3455
48	3419
49	3384
50	3349

MM	ML
51	3313
52	3278
53	3243
54	3208
55	3173
56	3138
57	3103
58	3069
59	3034
60	2999
61	2965
62	2930
63	2896
64	2861
65	2827
66	2793
67	2759
68	2725
69	2690
70	2657
71	2623
72	2589
73	2555
74	2521
75	2488
76	2454
77	2420
78	2387
79	2353
80	2320
81	2287
82	2254
83	2220
84	2187
85	2154
86	2121
87	2089
88	2056
89	2023
90	1990
91	1958
92	1925
93	1893
94	1860
95	1828
96	1795
97	1763
98	1731
99	1699
100	1667

MM	ML
101	1635
102	1603
103	1571
104	1539
105	1508
106	1476
107	1444
108	1413
109	1381
110	1350
111	1318
112	1287
113	1256
114	1225
115	1194
116	1163
117	1132
118	1101
119	1070
120	1039
121	1009
122	978
123	947
124	917
125	886
126	856
127	826
128	796
129	765
130	735
131	705
132	675
133	645
134	615
135	586
136	556
137	526
138	497
139	467
140	438
141	408
142	379
143	350
144	320
145	291
146	262
147	233
148	204
149	175
150	146

A4. SEQUENCE IIIG TEST FUEL ANALYSIS

PRODUCT: EEE Unleaded Gasoline
PRODUCT CODE: HF003

Batch No.: 99C-9
TMO No.: _____
Tank No.: 2014
Analysis Date: 10/19/99
Shipment Date: _____

TEST	METHOD	UNITS	FED Specs		SFC SPECIFICATIONS			RESULTS
			MIN	MAX	MIN	TARGET	MAX	
Distillation - IBP	ASTM D86	*F	75	95	75		95	83
5%		*F						109
10%		*F	120	135	120		135	124
20%		*F						147
30%		*F						171
40%		*F						200
50%		*F	200	230	200		230	221
60%		*F						232
70%		*F						243
80%		*F						261
90%		*F	305	325	305		325	315
95%		*F						334
Distillation - EP		*F		415			415	383
Recovery		vol %				Report		97.7
Residue		vol %				Report		1.0
Loss		vol %				Report		1.3
Gravity	ASTM D4052	*API	58.7	61.2	58.7		61.2	59.0
Density	ASTM D4052	kg/l			0.734		0.744	0.742
Reid Vapor Pressure	ASTM D323	psi	8.7	9.2	8.7		9.2	9.2
Reid Vapor Pressure	ASTM D5191	psi				Report		9.14
Carbon	ASTM D3343	wt fraction				Report		0.8652
Carbon	ASTM E191	wt fraction				Report		0.8613
Hydrogen	ASTM E191	wt fraction				Report		0.133
Hydrogen/Carbon ratio	ASTM E191	mole/mole				Report		1.840
Oxygen	ASTM D4815	wt %					0.05	<0.05
Sulfur	ASTM D4294	wt %		0.1			0.1	<0.015
Lead	ASTM D3237	g/gal		0.05			0.01	<0.01
Phosphorous	ASTM D3231	g/gal		0.005			0.005	<0.0008
Composition, aromatics	ASTM D1319	vol %		35.0			35.0	28.3
Composition, olefins	ASTM D1319	vol %		10.0			10.0	0.5
Composition, saturates	ASTM D1319	vol %				Report		71.2
Particulate matter	ASTM D5452	mg/l					1	0.6
Oxidation Stability	ASTM D525	minutes			240			>1000
Copper Corrosion	ASTM D130						1	1
Gum content, washed	ASTM D381	mg/100mls					5	1
Fuel Economy Numerator/C Density	ASTM E191				2401		2441	2431
C Factor	ASTM E191					Report		0.9982
Research Octane Number	ASTM D2699		93.0		96.0			98.5
Motor Octane Number	ASTM D2700					Report		89.7
Sensitivity			7.5		7.5			8.8
Net Heating Value, btu/lb	ASTM D3338	btu/lb				Report		18477
Net Heating Value, btu/lb	ASTM D240	btu/lb				Report		18457
Color	VISUAL	1.75 ptb				Report		Red

APPROVED BY: _____

ANALYST KMW

A5. SEQUENCE IIIG TEST CONTROL CHART TECHNIQUE FOR DEVELOPING AND APPLYING SEVERITY ADJUSTMENTS (SA)

Refer to "*The Lubricant Test Monitoring System*", available from the ASTM TMC, for information on the control chart technique and application of severity adjustments.

A6. SEQUENCE IIIG TEST REPORT Forms and Data Dictionary

Note: The actual report forms and data dictionary must be downloaded separately from the ASTM Test Monitoring Center Web Page at <http://astmtmc.cmu.edu/> or can be obtained in hardcopy format from the TMC.

Annex A7

Fig. A7.1 Air-to-Fuel ratio control flow chart

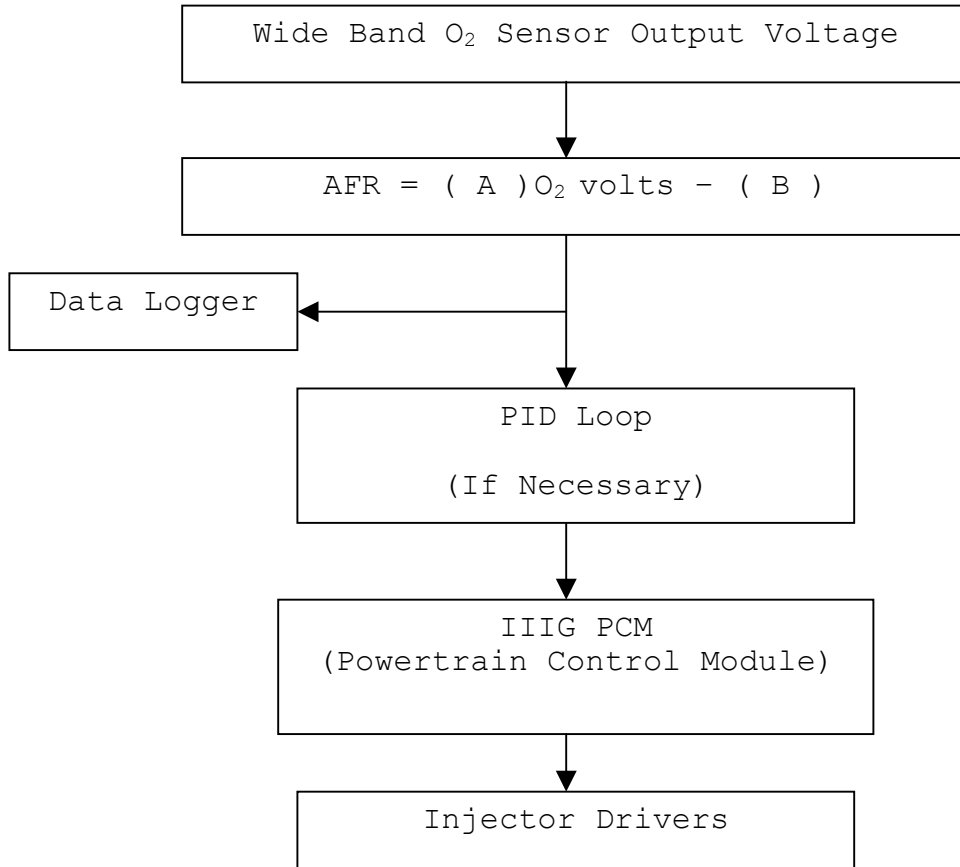

A & B derived from sensor calibration procedure and scaled to oscillating voltage from 100mv to 900mv input to PCM. Adjust B term as necessary during first hour of test condition to control at 15:1 air-to-fuel ratio.

Table A7.1 Sequence IIIF Air-to-Fuel Equivalence Ratio Chart for Specified

Fuel (C H)x
1.860

Composition by Weight: %C %H Stoichiometric AFR - 14.530
86.50 13.50

Equivalence Ratios			Emissions by Volume (Dry)				Moisture
AFR	Lambda	Gamma	%O2	%H2	%CO	%CO2	%H2O
7.265	0.500	2.000	0.000	13.635	19.975	2.968	7.149
7.555	0.520	1.923	0.000	12.557	19.179	3.387	7.772
7.846	0.540	1.852	0.000	11.536	18.379	3.817	8.344
8.137	0.560	1.786	0.000	10.571	17.575	4.258	8.868
8.427	0.580	1.724	0.000	9.660	16.767	4.709	9.346
8.718	0.600	1.667	0.000	8.803	15.954	5.170	9.780
9.008	0.620	1.613	0.000	7.997	15.137	5.641	10.173
9.299	0.640	1.562	0.000	7.241	14.317	6.122	10.526
9.589	0.660	1.515	0.000	6.533	13.494	6.611	10.843
9.880	0.680	1.471	0.000	5.872	12.670	7.107	11.125
10.171	0.700	1.429	0.000	5.256	11.844	7.611	11.374
10.461	0.720	1.389	0.000	4.682	11.018	8.120	11.593
10.752	0.740	1.351	0.000	4.149	10.192	8.634	11.783
11.042	0.760	1.316	0.000	3.655	9.369	9.153	11.947
11.333	0.780	1.282	0.000	3.197	8.549	9.674	12.086
11.624	0.800	1.250	0.000	2.774	7.732	10.196	12.202
11.914	0.820	1.220	0.000	2.382	6.921	10.720	12.297
12.205	0.840	1.190	0.000	2.021	6.116	11.243	12.373
12.495	0.860	1.163	0.000	1.689	5.319	11.765	12.432
12.786	0.880	1.136	0.000	1.383	4.529	12.285	12.474
13.077	0.900	1.111	0.000	1.101	3.748	12.802	12.502
13.367	0.920	1.087	0.000	0.842	2.977	13.315	12.517
13.658	0.940	1.064	0.000	0.604	2.216	13.824	12.519
13.948	0.960	1.042	0.000	0.385	1.466	14.327	12.511
14.239	0.980	1.020	0.000	0.184	0.727	14.825	12.494
14.530	1.000	1.000	0.000	0.000	0.000	15.317	12.467
14.820	1.020	0.980	0.439	0.000	0.000	14.996	12.238
15.111	1.040	0.962	0.861	0.000	0.000	14.688	12.017
15.401	1.060	0.943	1.265	0.000	0.000	14.392	11.803
15.692	1.080	0.926	1.653	0.000	0.000	14.108	11.597
15.982	1.100	0.909	2.027	0.000	0.000	13.835	11.398
16.273	1.120	0.893	2.386	0.000	0.000	13.572	11.206
16.564	1.140	0.877	2.732	0.000	0.000	13.320	11.021
16.854	1.160	0.862	3.065	0.000	0.000	13.076	10.841
17.145	1.180	0.847	3.386	0.000	0.000	12.841	10.667
17.435	1.200	0.833	3.696	0.000	0.000	12.614	10.498
17.726	1.220	0.820	3.995	0.000	0.000	12.396	10.335
18.017	1.240	0.806	4.284	0.000	0.000	12.185	10.177
18.307	1.260	0.794	4.563	0.000	0.000	11.980	10.024
18.598	1.280	0.781	4.833	0.000	0.000	11.783	9.875
18.888	1.300	0.769	5.094	0.000	0.000	11.592	9.730
19.179	1.320	0.758	5.347	0.000	0.000	11.407	9.590
19.470	1.340	0.746	5.592	0.000	0.000	11.228	9.453
19.760	1.360	0.735	5.830	0.000	0.000	11.054	9.321
20.051	1.380	0.725	6.060	0.000	0.000	10.886	9.192
20.341	1.400	0.714	6.283	0.000	0.000	10.723	9.067
20.632	1.420	0.704	6.500	0.000	0.000	10.564	8.945
20.923	1.440	0.694	6.710	0.000	0.000	10.410	8.826
21.213	1.460	0.685	6.915	0.000	0.000	10.261	8.710
21.504	1.480	0.676	7.113	0.000	0.000	10.116	8.598
21.794	1.500	0.667	7.306	0.000	0.000	9.975	8.488

Theoretical Exhaust Gas Relationships for Specified EEE Test Fuel

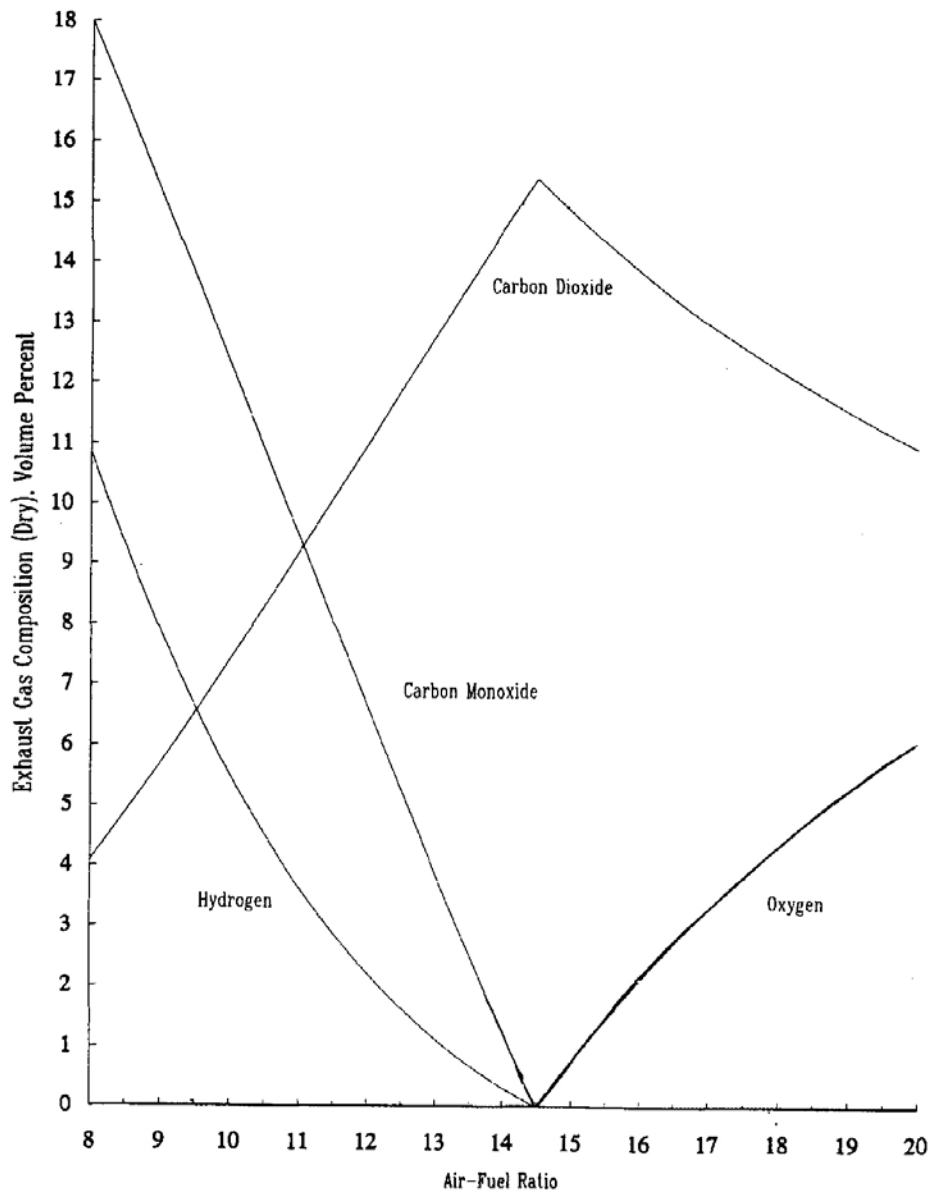

Note - Use corrected values for oxygen and carbon dioxide volumes; see text

Fig. A7.2 Sequence III F Air-to-Fuel Ratio for Specified Fuel ($\text{CH}_{1.860}$)_x

Annex A8

Sequence III G On-Test Control Settings

Test Parameter	Setpoint	Units	Acronym
Engine Speed	3600	RPM	SPEED
Dyno Torque	250	Nm	LOAD

Temperature

Oil Filter Block	150	°C	TOLFLT
Oil Sump	R	°C	TOLSMP
Engine Coolant Out	115	°C	TCLEO
Engine Coolant In	R	°C	TCLEI
Inlet Air Adapter	35	°C	TAIRIN
Dewpoint	16.1	°C	DEWPT
Breather Tube Coolant Outlet	40	°C	TCOND
Blowby Gas Outlet	R	°C	TBLBY
Fuel	R	°C	TFUELIN
Ambient Air	R	°C	TAMB
Right Exhaust Manifold Coolant Out	R	°C	TMMRO
Left Exhaust Manifold Coolant Out	R	°C	TMMLO

Pressure

Oil Filter Inlet	R	kPa	POLFTR
Oil Gallery	R	kPa	POLENG
Fuel	365	kPa	PFUEL
Inlet Air Adapter	0.05	kPa	PAIRIN
Intake Manifold Vacuum	R	kPa	PINVAC
Crankcase	R	kPa	PCC
Exhaust Back Pressure Right	6	kPa	PEXHBR
Exhaust Back Pressure Left	6	kPa	PEXHBL

Flow

Engine Coolant	160	L/m	FCLEO
Breather Tube	10	L/m	FCOND
Exhaust Manifold Left	8	L/m	FMML
Exhaust Manifold Right	8	L/m	FMMR

AFR

Air-to-Fuel Ratio Left	15.0:1	:1	AFRL
Air-to-Fuel Ratio Right	15.0:1	:1	AFRR

Seq. III G Test States
Dyno Speed

Annex A8.2

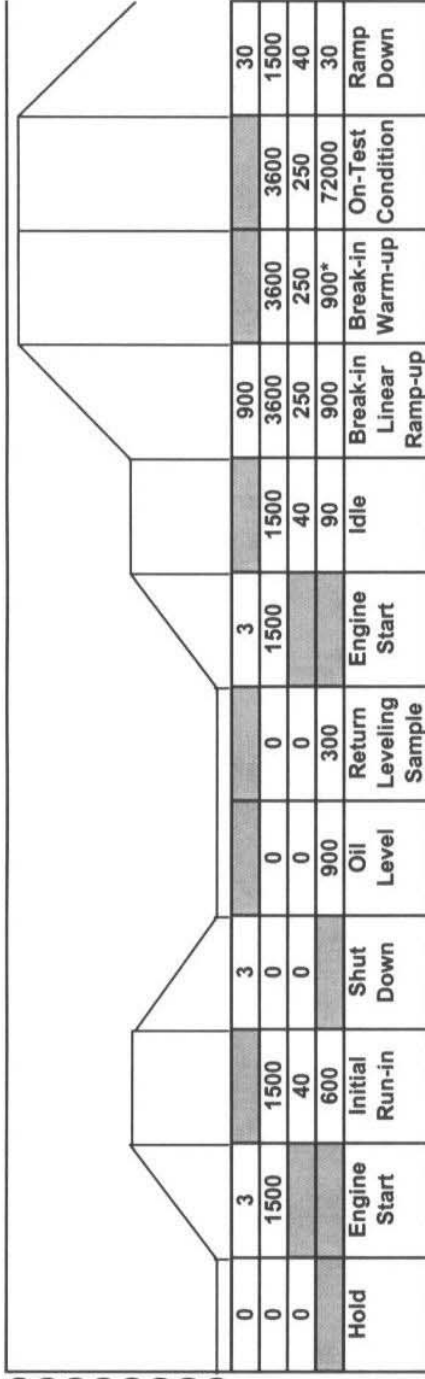

Ramp Time (seconds)	3	0	3	0	0	0	3	1500	3600	900	3600	3600	250	900*	72000	30	1500
Dyno Speed Setpoint	1500	1500	0	0	0	0	1500	1500	3600	3600	3600	3600	250	900*	72000	30	1500
Dyno Load Setpoint	40	40	0	0	0	0	0	0	0	0	0	0	250	900*	72000	30	1500
Step Time (seconds)	600	600	900	900	300	Return Leveling Sample	Engine Start	Idle	Break-in Linear Ramp-up	Break-in Linear Ramp-up	Break-in Linear Ramp-up	Break-in Linear Ramp-up	Break-in Linear Ramp-up	Break-in Linear Ramp-up	Break-in Linear Ramp-up	Break-in Linear Ramp-up	Break-in Linear Ramp-up
State Name	Engine Start	Initial Run-in	Shut Down	Oil Level	Return Leveling Sample	Engine Start	Idle	Break-in Linear Ramp-up	Break-in Linear Ramp-up	Break-in Linear Ramp-up	Break-in Linear Ramp-up	Break-in Linear Ramp-up	Break-in Linear Ramp-up	Break-in Linear Ramp-up	Break-in Linear Ramp-up	Break-in Linear Ramp-up	Break-in Linear Ramp-up

Temperature °C	50	50	50	50	50	50	50	50	50	50	150	150	150	115	115	115	50
Oil Filter Block	50	50	50	50	50	50	50	50	50	50	150	150	150	115	115	115	50
Engine Coolant Out	50	50	50	50	50	50	50	50	50	50	115	115	115	115	115	115	50
Condenser Coolant Out	40	40	40	40	40	40	40	40	40	40	40	40	40	40	40	40	40

Pressure kPa	3	3	3	3	3	3	3	3	3	3	3	3	3	3	3	3	3
Exh. Back Right/Left	3	3	3	3	3	3	3	3	3	3	3	3	3	3	3	3	3
Inlet Air	0.05	0.05	0.05	0.05	0.05	0.05	0.05	0.05	0.05	0.05	0.05	0.05	0.05	0.05	0.05	0.05	0.05
Fuel	Off	365	365	Off	0.05	Off	365	365	365	365	365	365	365	365	365	365	365

Flow L/m	160	160	160	160	160	160	160	160	160	160	160	160	160	160	160	160	160
Engine Coolant	160	160	160	160	160	160	160	160	160	160	160	160	160	160	160	160	160
Condenser Coolant	10	10	10	10	10	10	10	10	10	10	10	10	10	10	10	10	10
Oil Cooler (3-way)	12	12	12	12	12	12	12	12	12	12	12	12	12	12	12	12	12

* Typical warm-up transition time to on test condition about 8 minutes.
 ** Typical warm-up transition time to on test condition about 18 minutes.
 All ramp times are linear with respect to dyno speed and load settings.
 All temp., press., and flow settings are setpoint changes between states. Control systems should allow for overshoot and stabilization.
 SLC 06/10/02 Pg.1

Annex A8.2

Seq. III G Test States
Dyno Speed

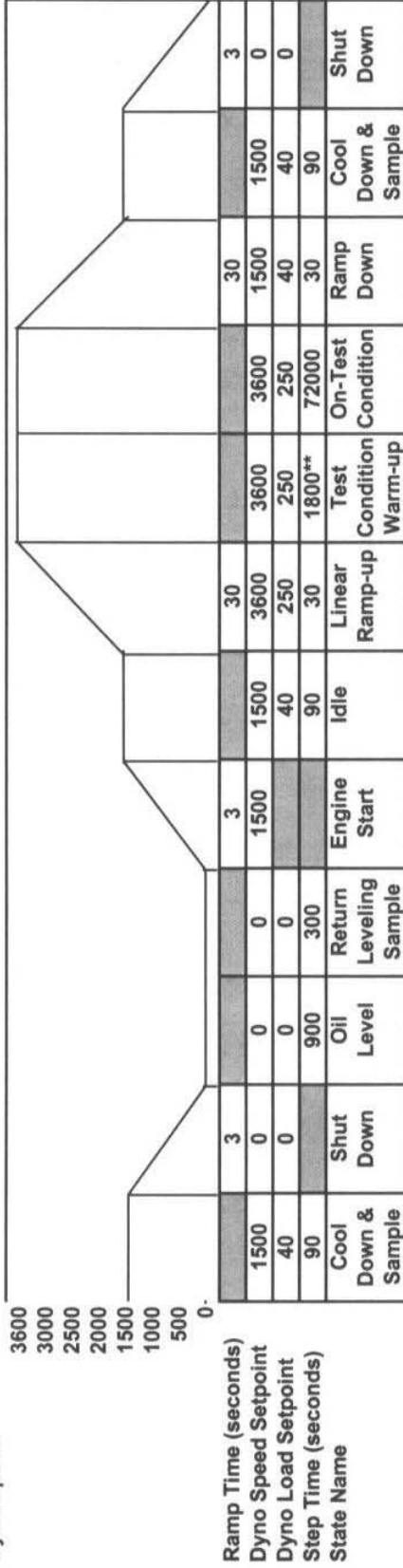

Temperature °C
Oil Filter Block
Engine Coolant Out
Condenser Coolant Out

Pressure kPa
Exh. Back Right/Left
Inlet Air
Fuel

3	3	3	3	3	3	3	3	3	3	3	3	3	3	3
0.05	0.05	0.05	0.05	0.05	0.05	0.05	0.05	0.05	0.05	0.05	0.05	0.05	0.05	0.05
365	365	Off	Off	365	365	365	365	365	365	365	365	365	365	Off

Flow L/m
Engine Coolant
Condenser Coolant
Oil Cooler (3-way)

160	160	160	160	160	160	160	160	160	160	160	160	160	160	160
10	10	10	10	10	10	10	10	10	10	10	10	10	10	10
12	12	12	12	12	12	12	12	12	12	12	12	12	12	12

Annex A9
Sequence IIIG Quality Index U&L Values
(Effective 5/23/01)

Controlled Parameters U&L Values to be determined	Quality Index U&L Values ^e	
	L	U
Speed	3595	3605
Load	199.02	200.98
Air-to-Fuel Ratio	14.87	15.13
Condenser Coolant Outlet Temperature	39.77	40.23
Engine Coolant Outlet Temperature	121.54	122.46
Oil Filter Block Temperature	154.58	155.42
Exhaust Back Pressure	5.92	6.08
Intake Air Pressure	0.041	0.059
Engine Coolant Flow	158.57	161.43

^e IIIF Values shown for example purposes only; IIIG values to be calculated after matrix.

Sequence IIIG Required Resolution for Data Acquisition

Controlled Parameters	Units	Required Resolution*
Speed	r/min	5.0
Load	N•m	5.1
Air-to-Fuel Ratio	--	5.2
Condenser Coolant Outlet Temperature	°C	5.1
Engine Coolant Outlet Temperature	°C	5.1
Oil Filter Block Temperature	°C	5.1
Exhaust Back Pressure	kPa	5.2
Intake Air Pressure	kPa	5.3
Condenser Coolant Flow	L/min	5.2
Engine Coolant Flow	L/min	5.1

*Decimal point is counted in format.

Maximum System Time Response - for controlled (QI) parameters only.

Speed - 0.10s
Torque - 0.60s
Coolant Flow - 8.0s
Intake Air Pressure - 0.75s
Exhaust Backpressure - 1.20s
Temperatures - 2.40s

Annex A10
Engine Oil Level Data Sheet

Test Number: _____

Oil Sample: #N/A mL = Initial Oil Level

	Run In	20	40	60	80	100	EOT TOTAL
Initial Fill = 5.50L = 5500 mL							
Remove 472 mL Purge Sample	<input type="checkbox"/>					<input type="checkbox"/>	
Remove 472 mL Leveling Sample		<input type="checkbox"/>	<input type="checkbox"/>	<input type="checkbox"/>	<input type="checkbox"/>		
Remove 236 mL Analysis Sample	<input type="checkbox"/>					<input type="checkbox"/>	
Remove 59 mL Analysis Sample		<input type="checkbox"/>	<input type="checkbox"/>	<input type="checkbox"/>	<input type="checkbox"/>		
Replace 472 mL Purge Sample	<input type="checkbox"/>					<input type="checkbox"/>	
Add 236 mL to Replace Sample							
Add 59 mL to Replace Sample		<input type="checkbox"/>	<input type="checkbox"/>	<input type="checkbox"/>	<input type="checkbox"/>		
Add 472 mL New Oil		<input type="checkbox"/>	<input type="checkbox"/>	<input type="checkbox"/>	<input type="checkbox"/>		0
Dipstick Level After Draindown (mm)							
Leveling Sample Added (mL)		#N/A	#N/A	#N/A	#N/A		
Leveling Sample Discarded (mL)		0	0	0	0		0
Resulting Dipstick Level (mm)		#N/A	#N/A	#N/A	#N/A		
Computed Oil Level, Low (mL)	0	#N/A	#N/A	#N/A	#N/A	#N/A	#N/A
Performed By:							

20-Hour Oil Consumption (mL)

Cumulative Oil Consumption (mL)

#N/A

Total Oil Consumption = Total 472 mL New Oil Additions - Total Sample Discarded + EOT Oil Level Low - 236 mL

Initial Oil Level (mL) #N/A #N/A #N/A #N/A #N/A #N/A

Dipstick Drain Level (mL) #N/A #N/A #N/A #N/A #N/A #N/A

Drain Level + Added (mL) #N/A #N/A #N/A #N/A

Contact the test sponsor for a fully automated version of the oil level worksheet

All. Blowby Flow Rate Determination

PRES- SURE, kPa	TEMPERATURE, DEGREES C															
	15	16	17	18	19	20	21	22	23	24	25	26	27	28	29	30
105.0	1.064	1.062	1.061	1.059	1.057	1.055	1.053	1.052	1.050	1.048	1.046	1.045	1.043	1.041	1.039	1.038
104.5	1.062	1.060	1.058	1.056	1.054	1.053	1.051	1.049	1.047	1.046	1.044	1.042	1.040	1.039	1.037	1.035
104.0	1.059	1.057	1.056	1.054	1.052	1.050	1.048	1.047	1.045	1.043	1.041	1.040	1.038	1.036	1.034	1.033
103.5	1.057	1.055	1.053	1.051	1.049	1.048	1.046	1.044	1.042	1.041	1.039	1.037	1.035	1.034	1.032	1.030
103.0	1.054	1.052	1.050	1.049	1.047	1.045	1.043	1.042	1.040	1.038	1.036	1.035	1.033	1.031	1.029	1.028
102.5	1.052	1.050	1.048	1.046	1.044	1.043	1.041	1.039	1.037	1.035	1.034	1.032	1.030	1.029	1.027	1.025
102.0	1.049	1.047	1.045	1.044	1.042	1.040	1.038	1.036	1.035	1.033	1.031	1.030	1.028	1.026	1.024	1.023
101.5	1.046	1.045	1.043	1.041	1.039	1.037	1.036	1.034	1.032	1.030	1.029	1.027	1.025	1.024	1.022	1.020
101.0	1.044	1.042	1.040	1.038	1.037	1.035	1.033	1.031	1.030	1.028	1.026	1.024	1.023	1.021	1.019	1.018
100.5	1.041	1.039	1.038	1.036	1.034	1.032	1.031	1.029	1.027	1.025	1.024	1.022	1.020	1.019	1.017	1.015
100.0	1.039	1.037	1.035	1.033	1.031	1.030	1.028	1.026	1.025	1.023	1.021	1.019	1.018	1.016	1.014	1.013
99.5	1.036	1.034	1.032	1.031	1.029	1.027	1.025	1.024	1.022	1.020	1.019	1.017	1.015	1.013	1.012	1.010
99.0	1.033	1.032	1.030	1.028	1.026	1.025	1.023	1.021	1.019	1.018	1.016	1.014	1.013	1.011	1.009	1.008
98.5	1.031	1.029	1.027	1.025	1.024	1.022	1.020	1.019	1.017	1.015	1.013	1.012	1.010	1.008	1.007	1.005
98.0	1.028	1.026	1.025	1.023	1.021	1.019	1.018	1.016	1.014	1.013	1.011	1.009	1.007	1.006	1.004	1.002
97.5	1.026	1.024	1.022	1.020	1.019	1.017	1.015	1.013	1.012	1.010	1.008	1.007	1.005	1.003	1.002	1.000
97.0	1.023	1.021	1.019	1.018	1.016	1.014	1.012	1.011	1.009	1.007	1.006	1.004	1.002	1.001	0.999	0.997
96.5	1.020	1.019	1.017	1.015	1.013	1.012	1.010	1.008	1.006	1.005	1.003	1.001	1.000	0.998	0.996	0.995
96.0	1.018	1.016	1.014	1.012	1.011	1.009	1.007	1.006	1.004	1.002	1.000	0.999	0.997	0.995	0.994	0.992
95.5	1.015	1.013	1.011	1.010	1.008	1.006	1.005	1.003	1.001	1.000	0.998	0.996	0.994	0.993	0.991	0.990
95.0	1.012	1.011	1.009	1.007	1.005	1.004	1.002	1.000	0.999	0.997	0.995	0.994	0.992	0.990	0.989	0.987
94.5	1.010	1.008	1.006	1.004	1.003	1.001	0.999	0.998	0.996	0.994	0.993	0.991	0.989	0.988	0.986	0.984
94.0	1.007	1.005	1.004	1.002	1.000	0.998	0.997	0.995	0.993	0.992	0.990	0.988	0.987	0.985	0.983	0.982

Table All.1 Blowby Flow Rate Correction Factor

PRES- SURE, kPa	TEMPERATURE, DEGREES C														
	31	32	33	34	35	36	37	38	39	40	41	42	43	44	45
105.0	1.036	1.034	1.033	1.031	1.029	1.028	1.026	1.024	1.023	1.021	1.019	1.018	1.016	1.014	1.013
104.5	1.033	1.032	1.030	1.028	1.027	1.025	1.023	1.022	1.020	1.018	1.017	1.015	1.014	1.012	1.010
104.0	1.031	1.029	1.028	1.026	1.024	1.023	1.021	1.019	1.018	1.016	1.014	1.013	1.011	1.010	1.008
103.5	1.028	1.027	1.025	1.023	1.022	1.020	1.018	1.017	1.015	1.014	1.012	1.010	1.009	1.007	1.006
103.0	1.026	1.024	1.023	1.021	1.019	1.018	1.016	1.014	1.013	1.011	1.010	1.008	1.006	1.005	1.003
102.5	1.024	1.022	1.020	1.018	1.017	1.015	1.014	1.012	1.010	1.009	1.007	1.005	1.004	1.002	1.001
102.0	1.021	1.019	1.018	1.016	1.014	1.013	1.011	1.009	1.008	1.006	1.005	1.003	1.001	1.000	0.998
101.5	1.019	1.017	1.015	1.014	1.012	1.010	1.009	1.007	1.005	1.004	1.002	1.001	0.999	0.997	0.996
101.0	1.016	1.014	1.013	1.011	1.009	1.008	1.006	1.005	1.003	1.001	1.000	0.998	0.997	0.995	0.993
100.5	1.013	1.012	1.010	1.009	1.007	1.005	1.004	1.002	1.000	0.999	0.997	0.996	0.994	0.992	0.991
100.0	1.011	1.009	1.008	1.006	1.004	1.003	1.001	1.000	0.998	0.996	0.995	0.993	0.992	0.990	0.988
99.5	1.008	1.007	1.005	1.003	1.002	1.000	0.999	0.997	0.995	0.994	0.992	0.991	0.989	0.988	0.986
99.0	1.006	1.004	1.003	1.001	0.999	0.998	0.996	0.995	0.993	0.991	0.990	0.988	0.987	0.985	0.984
98.5	1.003	1.002	1.000	0.998	0.997	0.995	0.994	0.992	0.990	0.989	0.987	0.986	0.984	0.983	0.981
98.0	1.001	0.999	0.998	0.996	0.994	0.993	0.991	0.989	0.988	0.986	0.985	0.983	0.982	0.980	0.979
97.5	0.998	0.997	0.995	0.993	0.992	0.990	0.989	0.987	0.985	0.984	0.982	0.981	0.979	0.978	0.976
97.0	0.996	0.994	0.992	0.991	0.989	0.988	0.986	0.984	0.983	0.981	0.980	0.978	0.977	0.975	0.974
96.5	0.993	0.991	0.990	0.988	0.987	0.985	0.983	0.982	0.980	0.979	0.977	0.976	0.974	0.973	0.971
96.0	0.991	0.989	0.987	0.986	0.984	0.982	0.981	0.979	0.978	0.976	0.975	0.973	0.972	0.970	0.968
95.5	0.988	0.986	0.985	0.983	0.982	0.980	0.978	0.977	0.975	0.974	0.972	0.971	0.969	0.967	0.966
95.0	0.985	0.984	0.982	0.981	0.979	0.977	0.976	0.974	0.973	0.971	0.970	0.968	0.966	0.965	0.963
94.5	0.983	0.981	0.980	0.978	0.976	0.975	0.973	0.972	0.970	0.969	0.967	0.965	0.964	0.962	0.961
94.0	0.980	0.979	0.977	0.975	0.974	0.972	0.971	0.969	0.968	0.966	0.964	0.963	0.961	0.960	0.958

Table A11.1 Blowby Flow Rate Correction Factor (continued)

PRES- SURE, kPa	TEMPERATURE, DEGREES C														
	46	47	48	49	50	51	52	53	54	55	56	57	58	59	60
105.0	1.011	1.010	1.008	1.007	1.005	1.003	1.002	1.000	0.999	0.997	0.996	0.994	0.993	0.991	0.990
104.5	1.009	1.007	1.006	1.004	1.003	1.001	1.000	0.998	0.996	0.995	0.993	0.992	0.990	0.989	0.987
104.0	1.006	1.005	1.003	1.002	1.000	0.999	0.997	0.996	0.994	0.993	0.991	0.990	0.988	0.987	0.985
103.5	1.004	1.002	1.001	0.999	0.998	0.996	0.995	0.993	0.992	0.990	0.989	0.987	0.986	0.984	0.983
103.0	1.002	1.000	0.998	0.997	0.995	0.994	0.992	0.991	0.989	0.988	0.986	0.985	0.983	0.982	0.980
102.5	0.999	0.998	0.996	0.995	0.993	0.991	0.990	0.988	0.987	0.985	0.984	0.982	0.981	0.979	0.978
102.0	0.997	0.995	0.994	0.992	0.991	0.989	0.988	0.986	0.984	0.983	0.981	0.980	0.979	0.977	0.976
101.5	0.994	0.993	0.991	0.990	0.988	0.987	0.985	0.984	0.982	0.981	0.979	0.978	0.976	0.975	0.973
101.0	0.992	0.990	0.989	0.987	0.986	0.984	0.983	0.981	0.980	0.978	0.977	0.975	0.974	0.972	0.971
100.5	0.989	0.988	0.986	0.985	0.983	0.982	0.980	0.979	0.977	0.976	0.974	0.973	0.971	0.970	0.968
100.0	0.987	0.985	0.984	0.982	0.981	0.979	0.978	0.976	0.975	0.973	0.972	0.970	0.969	0.967	0.966
99.5	0.984	0.983	0.981	0.980	0.978	0.977	0.975	0.974	0.972	0.971	0.969	0.968	0.966	0.965	0.964
99.0	0.982	0.980	0.979	0.977	0.976	0.974	0.973	0.971	0.970	0.968	0.967	0.965	0.964	0.963	0.961
98.5	0.979	0.978	0.976	0.975	0.973	0.972	0.970	0.969	0.967	0.966	0.965	0.963	0.962	0.960	0.959
98.0	0.977	0.975	0.974	0.972	0.971	0.969	0.968	0.966	0.965	0.964	0.962	0.961	0.959	0.958	0.956
97.5	0.975	0.973	0.971	0.970	0.968	0.967	0.965	0.964	0.963	0.961	0.960	0.958	0.957	0.955	0.954
97.0	0.972	0.970	0.969	0.967	0.966	0.964	0.963	0.962	0.960	0.959	0.957	0.956	0.954	0.953	0.951
96.5	0.969	0.968	0.966	0.965	0.963	0.962	0.961	0.959	0.958	0.956	0.955	0.953	0.952	0.950	0.949
96.0	0.967	0.965	0.964	0.962	0.961	0.959	0.958	0.957	0.955	0.954	0.952	0.951	0.949	0.948	0.946
95.5	0.964	0.963	0.961	0.960	0.958	0.957	0.956	0.954	0.953	0.951	0.950	0.948	0.947	0.945	0.944
95.0	0.962	0.960	0.959	0.957	0.956	0.954	0.953	0.952	0.950	0.949	0.947	0.946	0.944	0.943	0.942
94.5	0.959	0.958	0.956	0.955	0.953	0.952	0.951	0.949	0.948	0.946	0.945	0.943	0.942	0.940	0.939
94.0	0.957	0.955	0.954	0.952	0.951	0.949	0.948	0.947	0.945	0.944	0.942	0.941	0.939	0.938	0.937

Table A11.1 Blowby Flow Rate Correction Factor (continued)

A12. SAFETY PRECAUTIONS

A12.1 *General Information*

A12.1.1 The operating of engine tests can expose personnel and facilities to a number of safety hazards. It is recommended that only personnel who are thoroughly trained and experienced in engine testing should undertake the design, installation, and operations of engine test stands.

A12.1.2 Each laboratory conducting engine tests should have their test installation inspected and approved by their Safety Department. Personnel working on the engines should be provided with proper tools, be alert to common sense safety practices, and avoid contact with moving, or hot engine parts, or both. Guards should be installed around all external moving or hot parts. When engines are operating at high speeds, heavy-duty guards are required, and personnel should be cautioned against working alongside the engine and coupling shaft. Barrier protection should be provided for personnel. All fuel lines, oil lines, and electrical wiring should be properly routed, guarded, and kept in good order. Scraped knuckles, minor burns, and cuts are common, if proper safety precautions are not taken. Safety masks or glasses should always be worn by personnel working on the engines and no loose or flowing clothing, including long hair or other accessory to dress which could become entangled, should be worn near running engines.

A12.1.3 The external parts of the engines and the floor area around the engines should be kept clean and free of oil and fuel spills. In addition, all working areas should be free of tripping hazards. In case of injury, no matter how slight, first aid attention should be applied at once and the incident reported. Personnel should be alert for leaking fuel or exhaust gas. Leaking fuel represents a fire hazard and exhaust gas fumes are noxious. Containers of oil or fuel cannot be permitted to accumulate in the testing area.

A12.1.4 The test installation should be equipped with a fuel shut-off valve, which is designed to automatically cut off the fuel supply to the engine when the engine is not running. A remote station for cutting off fuel from the test stand is recommended. Suitable interlocks should be provided so that the engine is automatically shutdown when any of the following events occur; engine loses oil pressure; dynamometer loses field current; engine overspeeds; exhaust system fails; room ventilation fails; or the fire protection system is activated.

A12.1.5 Consider an excessive vibration pickup interlock if equipment operates unattended. Fixed fire protection equipment should be provided.

A12.1.6 Normal precautions should be observed whenever using flammable solvents for cleaning purposes. Make sure adequate fire fighting equipment is immediately accessible.

A13. Sequence IIIG Blueprint Listing

A13.1 Blueprints for fabrication of the required stand apparatus are listed in Table A13.1. These blueprints are available from the TMC.

Print Number	Description
RX-116924-C	Flushing Tank
RX-117230-E	Flushing Tank System Piping Layout
RX-117231-C	Flushing Tank Schematic
RX-117350-D	Coolant Mixing Tank
RX-116169-A1, revision N	Flow Meter (multiple orifice) blowby
RX-118602-B	Ring Depth Gage
BX-310-2	<i>Valve Spring Load Measurement Apparatus</i>
RX-117431-C	Blowby Gas Surge Tank
RX-117294-A	Bushing, blowby adapter
RX-118137-C	Water in and out coolant flushing tank - Evertite

Table A13.1 Blueprint List