

**Sequence IIIG Engine Oil Certification Test
Engine Assembly Manual**

**Contact Person
Bruce Matthews
GM Powertrain
823 Joslyn Road
Pontiac, MI. 48340-2920
Phone 248-830-9197**

**Revision 17
December 3, 2015**

Table of Contents

Hardware usage guidelines	Section 0
Revision Timeline.....	Section 01
Cleaning and Pre Hone Preparation.....	Section 1
Cylinder Block Honing.....	Section 2
Short Block Assembly	Section 3
Front Cover, Rear cover, and Sump.....	Section 4
Cylinder Head and Valves	Section 5
Cylinder Head and Valves, Hardened Seat Inserts, PN 24502260S.....	Section 5a
Long Block Assembly.....	Section 6
Final Dress	Section 7
OH Technologies Special Engine Dress	Section 8

Section 0

Hardware usage guidelines

All materials used in this test must conform to acceptance guidelines as specified in the ASTM Sequence IIIG Test Method D 7320 accompanied by the direction and information contained in this Assembly Manual.

Any changes in procedures or substitutions of qualified parts or materials, must be approved by the Sequence IIIF / G Surveillance Panel prior to their use in non-reference and reference oil tests.

Any parts or materials specified in this document that are found to be unacceptable for testing, both pre and post test, must be reported to the Test Sponsor, the appropriate Critical Parts Distributor, and the ASTM Test Monitoring Center.

Unless otherwise directed, all parts and materials required for testing should be stored and used on a first in – first out basis following the guidelines outlined in the ASTM Test Monitoring Center Sequence IID and IIIE Information Letter #60 June 21, 1991.

Section 01

Revision Update Timeline

Sequence IIIG Engine Assembly Manual Update Revision Timeline

Latest Revision 17

Date 12/3/2015

Contact Person Rich Grundza TMC 412-365-1031

Bruce Matthews GM Pontiac 248-830-9197

Date	Sec.	Sheet	Topic	Comments	Info Letter
4/28/03	1	5A	Cleaning instructions	Removal of NAT50 / PDN50 soap residue	
4/28/03	3	8	Ring Color Code	Addition of color code identification	
4/28/03	4	1	Front Cover usage	Change to OHT epoxy impregnated front cover part #.	
4/28/03	4	12	Pan Gasket	Change to 2003 gasket part #.	
4/28/03	6	9	MAF part #	Add new mass airflow sensor part #.	
6/23/03	6	9	MAF part #	Add remanufactured part # 88961007	
6/23/03	7	6	MAF part #	Add remanufactured part # 88961007	
9/10/03	3	8	Ring Gap	Correct typo for top ring gap (0.064 to 0.64)	
9/10/03	5	1	Valve Spring Calibration	Change +/- load from 22N to 44N (5lbf. To 10lbf.)	IIIG-03-2
12/15/03	1	1	Block part #	Change block part # from drawing # to 24502286	IIIG-03-3
12/15/03	1	5	Solvent specification	Update to mineral spirit	
12/15/03	1	5A	Solvent specification	Update to mineral spirit	
12/15/03	1	6	Fastener	Update fastener usage	
12/15/03	2	7	Honer	Update ratchet feed setting	
12/15/03	2	8	Honer	Update honing procedure	
12/15/03	2	9	Honer	Update revised loads and target sizing	
12/15/03	2	10	Honer	New page, honer calibration requirements	
12/15/03	2	11	Honer	New page, honer maintenance requirements	
12/15/03	2	12	Honer	New page, honer maintenance requirements	
12/15/03	3	5	Solvent specification	Update to mineral spirit	
12/15/03	3	6	Fastener	Update fastener usage	
12/15/03	3	8	Rings	Update paint removal and solvent usage	
12/15/03	3	11	Camshaft	Update solvent usage and lubrication requirements	
12/15/03	4	5	Sealer	Update approved sealer specification	
12/15/03	4	12	Sealer	Update approved sealer specification	
12/15/03	5	1	Solvent specification	Update to mineral spirit	
12/15/03	6	1	Solvent specification	Update to mineral spirit	
12/15/03	6	2	Solvent specification	Update to mineral spirit	
12/15/03	6	6	Sealer	Update approved sealer specification	

Sequence IIIG Engine Assembly Manual Update Revision Timeline

Latest Revision 17

Date 12/3/2015

Contact Person Rich Grundza TMC 412-365-1031

Bruce Matthews GM Pontiac 248-830-9197

Date	Sec.	Sheet	Topic	Comments	Info Letter
12/15/03	6	11	Text	Update text block (injector flow testing) reference procedure	
12/15/03	7	4	Part #	Add new shield 24508586	
3/15/04	4	12	Silicone Sealer	Update sealer part numbers	IIIG-04-1
3/15/04	6	6	Sealer & Gasket	Update sealer and intake gasket part numbers	
11/3/04	3	7	Con Rod part numbers	Update to include Cast and PM part numbers	IIIG-04-3
11/3/04	3	9	Con Rod Torques	Update to include Cast and PM torque values	
11/3/04	4	1	Front Oil Seal	Update to new OHT part number	
11/3/04	4	5	Front Oil Seal	Update to new OHT part number	
11/3/04	4	9	Rear Oil Seal	Update to new OHT part number	
11/3/04	4	12	Oil Pan Gsket	Update to new OHT part number	
11/3/04	5	1	Exhaust Valve	Update to new SPO part number	
The following updates cover information letters IIIG-05 through IIIG-06-					
6/22/06	All Sections			Global text change from Mineral Spirits to Degreasing Solvent	
6/22/06	1	1	Bore alignment check	Change alignment check to optional	
6/22/06	1	6	Fastener Installation	Remove plastic mallet from usage text	
6/22/06	1	7	Torque Wrench	Add ETW-E180 torque wrench information	
6/22/06	2	8	Honing	Update according to S.P. direction 6/6/06	
6/22/06	3	2	Data recording	Add data recording Annex A.14	
6/22/06	3	5	Update	Update text and part numbers	
6/22/06	3	6	Update	Update view, fastener prep, and clearance spec.	
6/22/06	3	7	Piston & Rod	Update cleaning and rod orientation information	
6/22/06	3	8	Update and expand	Expand view and add additional sheet (8A)	
6/22/06	3	8A	New sheet	New sheet with expanded view and BC6 second ring info.	
6/22/06	3	9	Cast Rods	Remove cast rod information	
6/22/06	3	11	Fastener usage	Update fastener usage and inspection information	
6/22/06	3	12	Part number update	Update balance shaft part number	

Sequence IIIG Engine Assembly Manual Update Revision Timeline

Latest Revision 17

Date 12/3/2015

Contact Person Rich Grundza TMC 412-365-1031

Bruce Matthews GM Pontiac 248-830-9197

Date	Sec.	Sheet	Topic	Comments	Info Letter
6/22/06	4	2	Front Cover	Add usage information	
6/22/06	4	4	Oil filter adapter	Update sealer usage information	
6/30/06	4	7	Front Cover Assembly	Update view and part numbers	
6/30/06	4	8	Front Cover	Update fastener information	
7/20/06	4	9	Rear Cover	Update part numbers for rear cover and crankshaft seal	
7/20/06	4	10	Rear Cover	Update fastener usage	
2/1/06	4	11	Part number update	Update gasket part number	
2/5/06	4	13	Part number update	Update fastener part number information	
6/30/06	5	1	Valve & Springs	Update cleaning procedure and valve part number	
7/20/06	5	3	Cyl. Head fastener	Update part number information	
7/20/06	6	1	Lifter installation	Update cleaning info and installation information	
7/20/06	6	2	Pushron installation	Update cleaning info and degreasing solvent	
7/20/06	6	3	Rocker retainer	Update usage information	
7/20/06	6	6	Update	Update intake gasket part number	
The following updates cover changes through April 1, 2007					
3/30/07	1	7	Cylinder Head Fastener Torque	Fastener torque procedure for honing deck plates	
3/30/07	3	9	Rod Bolt Torque	Connecting rod torque + angle update for PM rods	
3/30/07	3	11	Pre-test Camshaft Lubrication	Updated procedure for EF-411 vs test oil lubricating process	
3/30/07	4	6	Front Cover Gasket	Update gasket part number changes	
3/30/07	5	3	Cylinder Head Fastener Torque	Fastener torque procedure for cylinder head installation	
3/30/07	6	5	Rocker Cover	Update rocker cover part number change	
3/30/07	6	8	Upper Intake Gasket	Update upper intake gasket part number change	
The following updates cover changes through February 22, 2010					
2/22/10	1	5A	Block Cleaning	Changed washer temp to metric value and added tolerance	
2/22/10	1	7	Stress Plates	Updated head gasket and bolt p/n, added source for bolts	
2/22/10	2	10	Honing Machine	Changed wording from calibrated to verified	

Sequence IIIG Engine Assembly Manual Update Revision Timeline

Latest Revision 17

Date 12/3/2015

Contact Person Rich Grundza TMC 412-365-1031

Bruce Matthews GM Pontiac 248-830-9197

Date	Sec.	Sheet	Topic	Comments	Info Letter
2/22/10	3	6	Thread Lubrication	Deleted note prohibiting thread lubrication	
2/22/10	3	8	Ring Gap Measurement	Deleted OHT3F-gages, added measurement in block	
2/22/10	4	9	Seal Installation	Added Kenmore J38196 tool for rear seal installation	
2/22/10	4	10	Rear Seal Housing	Allowed bolts to be used along as they remain servicable	
2/22/10	5	3	Head Assembly	Corrected short bolt p/n	
2/22/10	6	8	Upper Intake	Deleted stud, 24502453 and increased to 2 bolt 24505205	
The following updates cover changes through July 1, 2011					
7/1/11	1	2	New Block and Pre-Hone Prep	Updated part number for upper front cover pin	
7/1/11	1	4	New Block and Pre-Hone Prep	Revised notes E and F	
7/1/11	1	5	New Block and Pre-Hone Prep	Revised note A	
7/1/11	1	6	Main Cap Installation	Removed notes Y2 and Z, changed Y1 to Y and edited notes A, B and C	
7/1/11	1	7	Torque Plate Installation	Revised notes A, B, C and D and deleted note Z	
7/1/11	1	4	Fluid and Operations Guide	Corrected typos, deleted note 1, renumbered notes 2 and 3 and clarified step 4	
7/1/11	3	2	Engine block cleanliness	Revised note B	
7/1/11	3	3	Main Cap Installation	Added new sheet 3	
7/1/11	3	4	Camshaft bearing positioning	Moved from sheet 6	
7/1/11	3	5	Upper main bearing inspection	Renumbered as sheet 5	
			Installation		
7/1/11	3	6	Crankshaft cleaning, inspection and installation	Renumbered as sheet 6	
7/1/11	3	7	Lower Main installation	Renumbered sheet 6 as sheet 7	
7/1/11	3	8	Piston Pin and conneting rod	Updated connecting rod part number renumber sheet 7 as 8	
7/1/11	3	9	Piston installation and clearances	Renumbered sheet 8 as sheet 9	
7/1/11	3	9A	Piston ring installation	Removed BC-6 from piston orientation and added orientation	
			orientation and clearances	for oil ring expander renumber sheet 8A as 9A	
7/1/11	3	10	Piston and rod assembly install	Updated connecting rod and connecting rod bolt part number	

Sequence IIIG Engine Assembly Manual Update Revision Timeline

Latest Revision 17

Date 12/3/2015

Contact Person Rich Grundza TMC 412-365-1031

Bruce Matthews GM Pontiac 248-830-9197

Date	Sec.	Sheet	Topic	Comments	Info Letter
4/28/03	1	5A	Cleaning instructions	Removal of NAT50 / PDN50 soap residue	
4/28/03	3	8	Ring Color Code	Addition of color code identification	
4/28/03	4	1	Front Cover usage	Change to OHT epoxy impregnated front cover part #.	
4/28/03	4	12	Pan Gasket	Change to 2003 gasket part #.	
4/28/03	6	9	MAF part #	Add new mass airflow sensor part #.	
6/23/03	6	9	MAF part #	Add remanufactured part # 88961007	
6/23/03	7	6	MAF part #	Add remanufactured part # 88961007	
9/10/03	3	8	Ring Gap	Correct typo for top ring gap (0.064 to 0.64)	
9/10/03	5	1	Valve Spring Calibration	Change +/- load from 22N to 44N (5lbf. To 10lbf.)	IIIG-03-2
12/15/03	1	1	Block part #	Change block part # from drawing # to 24502286	IIIG-03-3
12/15/03	1	5	Solvent specification	Update to mineral spirit	
12/15/03	1	5A	Solvent specification	Update to mineral spirit	
12/15/03	1	6	Fastener	Update fastener usage	
12/15/03	2	7	Honer	Update ratchet feed setting	
12/15/03	2	8	Honer	Update honing procedure	
12/15/03	2	9	Honer	Update revised loads and target sizing	
12/15/03	2	10	Honer	New page, honer calibration requirements	
12/15/03	2	11	Honer	New page, honer maintenance requirements	
12/15/03	2	12	Honer	New page, honer maintenance requirements	
12/15/03	3	5	Solvent specification	Update to mineral spirit	
12/15/03	3	6	Fastener	Update fastener usage	
12/15/03	3	8	Rings	Update paint removal and solvent usage	
12/15/03	3	11	Camshaft	Update solvent usage and lubrication requirements	
12/15/03	4	5	Sealer	Update approved sealer specification	
12/15/03	4	12	Sealer	Update approved sealer specification	
12/15/03	5	1	Solvent specification	Update to mineral spirit	
12/15/03	6	1	Solvent specification	Update to mineral spirit	
12/15/03	6	2	Solvent specification	Update to mineral spirit	
12/15/03	6	6	Sealer	Update approved sealer specification	

Sequence IIIG Engine Assembly Manual Update Revision Timeline

Latest Revision 17

Date 12/3/2015

Contact Person Rich Grundza TMC 412-365-1031

Bruce Matthews GM Pontiac 248-830-9197

Date	Sec.	Sheet	Topic	Comments	Info Letter
12/15/03	6	11	Text	Update text block (injector flow testing) reference procedure	
12/15/03	7	4	Part #	Add new shield 24508586	
3/15/04	4	12	Silicone Sealer	Update sealer part numbers	IIIG-04-1
3/15/04	6	6	Sealer & Gasket	Update sealer and intake gasket part numbers	
11/3/04	3	7	Con Rod part numbers	Update to include Cast and PM part numbers	IIIG-04-3
11/3/04	3	9	Con Rod Torques	Update to include Cast and PM torque values	
11/3/04	4	1	Front Oil Seal	Update to new OHT part number	
11/3/04	4	5	Front Oil Seal	Update to new OHT part number	
11/3/04	4	9	Rear Oil Seal	Update to new OHT part number	
11/3/04	4	12	Oil Pan Gsket	Update to new OHT part number	
11/3/04	5	1	Exhaust Valve	Update to new SPO part number	
The following updates cover information letters IIIG-05 through IIIG-06-					
6/22/06	All Sections			Global text change from Mineral Spirits to Degreasing Solvent	
6/22/06	1	1	Bore alignment check	Change alignment check to optional	
6/22/06	1	6	Fastener Installation	Remove plastic mallet from usage text	
6/22/06	1	7	Torque Wrench	Add ETW-E180 torque wrench information	
6/22/06	2	8	Honing	Update according to S.P. direction 6/6/06	
6/22/06	3	2	Data recording	Add data recording Annex A.14	
6/22/06	3	5	Update	Update text and part numbers	
6/22/06	3	6	Update	Update view, fastener prep, and clearance spec.	
6/22/06	3	7	Piston & Rod	Update cleaning and rod orientation information	
6/22/06	3	8	Update and expand	Expand view and add additional sheet (8A)	
6/22/06	3	8A	New sheet	New sheet with expanded view and BC6 second ring info.	
6/22/06	3	9	Cast Rods	Remove cast rod information	
6/22/06	3	11	Fastener usage	Update fastener usage and inspection information	
6/22/06	3	12	Part number update	Update balance shaft part number	

Sequence IIIG Engine Assembly Manual Update Revision Timeline

Latest Revision 17

Date 12/3/2015

Contact Person Rich Grundza TMC 412-365-1031

Bruce Matthews GM Pontiac 248-830-9197

Date	Sec.	Sheet	Topic	Comments	Info Letter
6/22/06	4	2	Front Cover	Add usage information	
6/22/06	4	4	Oil filter adapter	Update sealer usage information	
6/30/06	4	7	Front Cover Assembly	Update view and part numbers	
6/30/06	4	8	Front Cover	Update fastener information	
7/20/06	4	9	Rear Cover	Update part numbers for rear cover and crankshaft seal	
7/20/06	4	10	Rear Cover	Update fastener usage	
2/1/06	4	11	Part number update	Update gasket part number	
2/5/06	4	13	Part number update	Update fastener part number information	
6/30/06	5	1	Valve & Springs	Update cleaning procedure and valve part number	
7/20/06	5	3	Cyl. Head fastener	Update part number information	
7/20/06	6	1	Lifter installation	Update cleaning info and installation information	
7/20/06	6	2	Pushron installation	Update cleaning info and degreasing solvent	
7/20/06	6	3	Rocker retainer	Update usage information	
7/20/06	6	6	Update	U pate intake gasket part number	
The following updates cover changes through April 1, 2007					
3/30/07	1	7	Cylinder Head Fastener Torque	Fastener torque procedure for honing deck plates	
3/30/07	3	9	Rod Bolt Torque	Connecting rod torque + angle update for PM rods	
3/30/07	3	11	Pre-test Camshaft Lubrication	Updated procedure for EF-411 vs test oil lubricating process	
3/30/07	4	6	Front Cover Gasket	Update gasket part number changes	
3/30/07	5	3	Cylinder Head Fastener Torque	Fastener torque procedure for cylinder head installation	
3/30/07	6	5	Rocker Cover	Update rocker cover part number change	
3/30/07	6	8	Upper Intake Gasket	Update upper intake gasket part number change	
The following updates cover changes through February 22, 2010					
2/22/10	1	5A	Block Cleaning	Changed washer temp to metric value and added tolerance	
2/22/10	1	7	Stress Plates	Updated head gasket and bolt p/n, added source for bolts	
2/22/10	2	10	Honing Machine	Changed wording from calibrated to verified	

Sequence IIIG Engine Assembly Manual Update Revision Timeline

Latest Revision 17

Date 12/3/2015

Contact Person Rich Grundza TMC 412-365-1031

Bruce Matthews GM Pontiac 248-830-9197

Date	Sec.	Sheet	Topic	Comments	Info Letter
2/22/10	3	6	Thread Lubrication	Deleted note prohibiting thread lubrication	
2/22/10	3	8	Ring Gap Measurement	Deleted OHT3F-gages, added measurement in block	
2/22/10	4	9	Seal Installation	Added Kenmore J38196 tool for rear seal installation	
2/22/10	4	10	Rear Seal Housing	Allowed bolts to be used along as they remain servicable	
2/22/10	5	3	Head Assembly	Corrected short bolt p/n	
2/22/10	6	8	Upper Intake	Deleted stud, 24502453 and increased to 2 bolt 24505205	
The following updates cover changes through July 1, 2011					
7/1/11	1	2	New Block and Pre-Hone Prep	Updated part number for upper front cover pin	
7/1/11	1	4	New Block and Pre-Hone Prep	Revised notes E and F	
7/1/11	1	5	New Block and Pre-Hone Prep	Revised note A	
7/1/11	1	6	Main Cap Installation	Removed notes Y2 and Z, changed Y1 to Y and edited notes A, B and C	
7/1/11	1	7	Torque Plate Installation	Revised notes A, B, C and D and deleted note Z	
7/1/11	1	4	Fluid and Operations Guide	Corrected typos, deleted note 1, renumbered notes 2 and 3 and clarified step 4	
7/1/11	3	2	Engine block cleanliness	Revised note B	
7/1/11	3	3	Main Cap Installation	Added new sheet 3	
7/1/11	3	4	Camshaft bearing positioning	Moved from sheet 6	
7/1/11	3	5	Upper main bearing inspection	Renumbered as sheet 5	
7/1/11	3	6	Crankshaft cleaning, inspection and installation	Renumbered as sheet 6	
7/1/11	3	7	Lower Main installation	Renumbered sheet 6 as sheet 7	
7/1/11	3	8	Piston Pin and conneting rod	Updated connecting rod part number renumber sheet 7 as 8	
7/1/11	3	9	Piston installation and clearances	Renumbered sheet 8 as sheet 9	
7/1/11	3	9A	Piston ring installation orientation and clearances	Removed BC-6 from piston orientation and added orientation for oil ring expander renumber sheet 8A as 9A	
7/1/11	3	10	Piston and rod assembly install	Updated connecting rod and connecting rod bolt part number	

Sequence IIIG Engine Assembly Manual Update Revision Timeline

Latest Revision 17

Date 12/3/2015

Contact Person Rich Grundza TMC 412-365-1031

Bruce Matthews GM Pontiac 248-830-9197

Date	Sec.	Sheet	Topic	Comments	Info Letter
				Renumbered sheet 9 as 10	
7/1/11	3	11	Oil gallery plugs and timing chain	Renumbered sheet 10 as 11	
			Damper		
7/1/11	3	12	Camshaft cleaning, etc	Revised note D, renumbered sheet 11 as sheet 12	
7/1/11	3	13	Balance shaft inspect & install	Removed balance shaft part number 24503588	
				Renumbered sheet 12 as 13	
7/1/11	3	14	Timing gear set	Renumbered sheet 13 as 14	
7/1/11	3	15	Timing gear set alignment & torque	Renumbered sheet 14 as 15	
7/1/11	4	10	Rear cover installation	Updated part number	
7/1/11	4	12	Oil pan gasket installation	Updated sealer information	
7/1/11	4	13	Oil pan installation	Removed bolt number 24502791	
7/1/11	5	1	Valve & spring assembly	Updated cylinder head part number	
7/1/11	5	3	Cylinder head installation	Clarified torque sequence	
7/1/11	6	1	Lifter pre-oiling and installation	Corrected typo in description B 2.	
7/1/11	6	5	Rocker cover installation	Deleted bolt with washer, part number 25534748 and added grommet, part number 25534749	
7/1/11	6	6	Intake gasket installation	Updated RTV sealer	
7/1/11	6	7	Lower intake manifold install	Revised intake manifold description and part number and added torque sequence	
7/1/11	6	8	Upper intake manifold install	Revised description and updated part number	
7/1/11	6	9	Throttle body installation	Updated part number	
7/1/11	6	11	Injector assembly installation	Updated part number for fuel injector and added second pressure regulator	
7/1/11	7	1	Coolant out and sensor	Added part number for coolant outlet gasket	
7/1/11	7	4	Crankshaft sensor shield	Revised part number	
7/1/11	7	6	Throttle body modification	Removed part numbers 88961007 and 12568877	
The following updates cover changes through April 10, 2012					
4/10/12	1	5A	New Block and Pre-Hone Prep	Revised length of time cleaning solution can be used	
4/10/12	1	6	New Block and Pre-Hone Prep	Revised the sequence of main bolt installation	
4/10/12	3	3	Piston installation and clearances	Revised the sequence of main bolt installation	

Sequence IIIG Engine Assembly Manual Update Revision Timeline

Latest Revision 17

Date 12/3/2015

Contact Person Rich Grundza TMC 412-365-1031

Bruce Matthews GM Pontiac 248-830-9197

Date	Sec.	Sheet	Topic	Comments	Info Letter
4/10/12	3	9	Piston installation and clearances	Revised target bore value for 12/2 pistons	
The following updates cover changes through May 02, 2013					
4/2/13	4	2	Front, Rear Cover and Sump	Increased the drop in clearance to 0.153 mm	
The following updates cover changes through March 25, 2014					
3/24/14	5a	1	Initial Measurements 24502260S head	Added Section to address initial measurement of heads	14-1
3/24/14	5a	2	Preparations for Reuse	Added Section to address preparations to reuse head	
3/24/14	5a	3	Additional Measurements	Added Section to address additional measurements	
3/24/14	5a	4	Final preparations	Added section for completion of steps to reuse head	
3/24/14	5a	5	Valve and Spring Assembly	Added section for valve and spring install in reused head	
3/24/14	5a	6	Gasket Install	Added section for installing head gaskets with reused head	
3/24/14	5a	7	Cylinder head installation	Added section for installation on engine of reused head	
The following updates cover changes through September 26, 2014					
9/26/14	2	9	Piston installation and clearances	Updated target bore size	
9/26/14	3	9	Piston installation and clearances	Updated target bore size and color codes for 7/8 run pistons	
The following updates cover changes through October 10, 2014					
10/10/14	2	10	Honing	Removed requirement for verification to be performed by qualified sunnen technician	
The following updates cover changes through August 4, 2015					
8/4/15	2	9A	Piston installation and clearances	Updated target bore size on new sheet 9A	
8/4/15	3	9	Piston installation and clearances	Updated target bore size and color codes for 9/10 run pistons	
The following updates cover changes through December 3, 2015					
12/3/15	5a	2	Preparations for Reuse	Revised valve recession limit from 0.005" to 0.010"	
12/3/15	5a	4	Final preparations	Revised seat width reuse criteria	

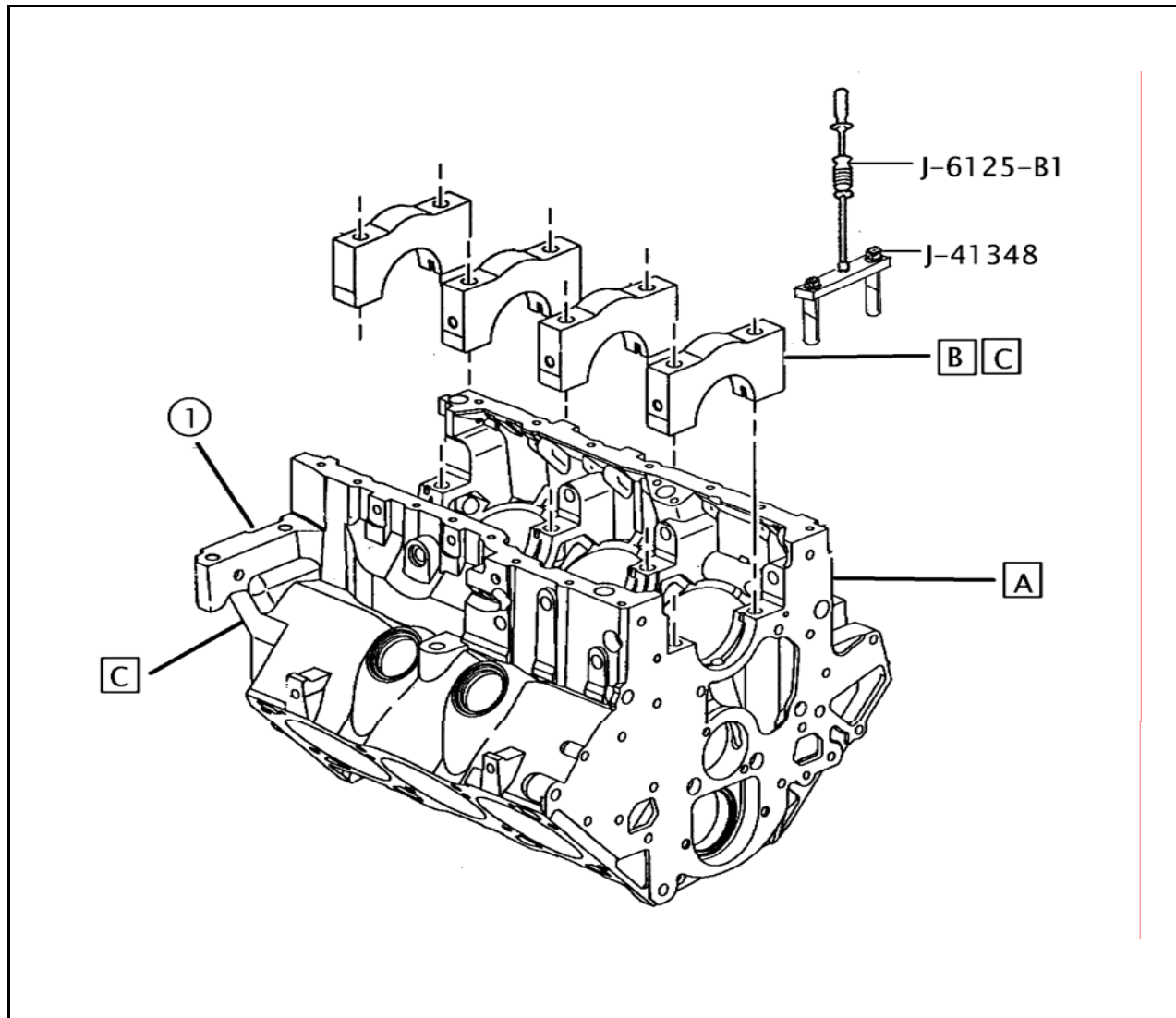

Description of Operation	
A	Upon introduction of a new block into the system, check for any damage to machined surfaces which might have occurred during shipping or handling. Optional: Check crankshaft main bore alignment using appropriate mandrel.
B	Remove main cap side & main bolts. Use Kent-Moore J-41348 main bearing cap puller (12Nm) & J-6125-1B slide hammer to remove main caps. Note: Main bearing caps are press fit. Do not hammer caps back and forth during removal. Damage to the caps may result in damage to engine bearings during test.
C	Record engine serial number and or assign a laboratory number and mark necessary identification on engine block and crankshaft main caps. Note: Do not use stamped tool set for marking identification on main caps.

Specification	
1	24502286 Block Assembly

REV	Date	Revision History
1	12/31/97	Block-1
2	12/15/03	Change from engineering drawing part # (24506028) to actual part # 24502286
3	06/22/06	Change main bore alignment check to optional
New Block and Pre-Hone Prep		Sequence III G

View	
Engine Block	
New block and pre-hone prep Serial Number Locations	
Section	Sheet
1	1

			Description of Operation			
					A	Install locating pins on front face.
B	Install locating pins on cylinder deck					
		C	Use OHT3F-071-1 reamer to size dip stick hole for calibrated dip stick			
		D	Deburr all leading edges of camshaft tunnel bores and oil gallery cross drilled intersections through tunnel bores using emery cloth, rotary tool with carbide cutters, stones, or wire wheels as necessary to remove sharp edges.			
			Specification			
			1	Modify 25536323 Pin Frt Cover Upper		
			2	25536323 Pin Fr+Al139t Cover Lower		
			3	25536320 Pin Cyl. Head Location		
			4	OHT3F-071-1 Reamer		
REV	Date	Revision History	View			
1	12/31/97	Block-2	Engine Block			
2	7/1/11	Updated Part Number for Upper front cover pin and deleted transmission pin	New block and pre-hone prep			
			Locating pin installation			
			Camshaft tunnel and dip stick prep			
New Block and Pre-Hone Prep			Sequence III G		Section	Sheet
					1	2

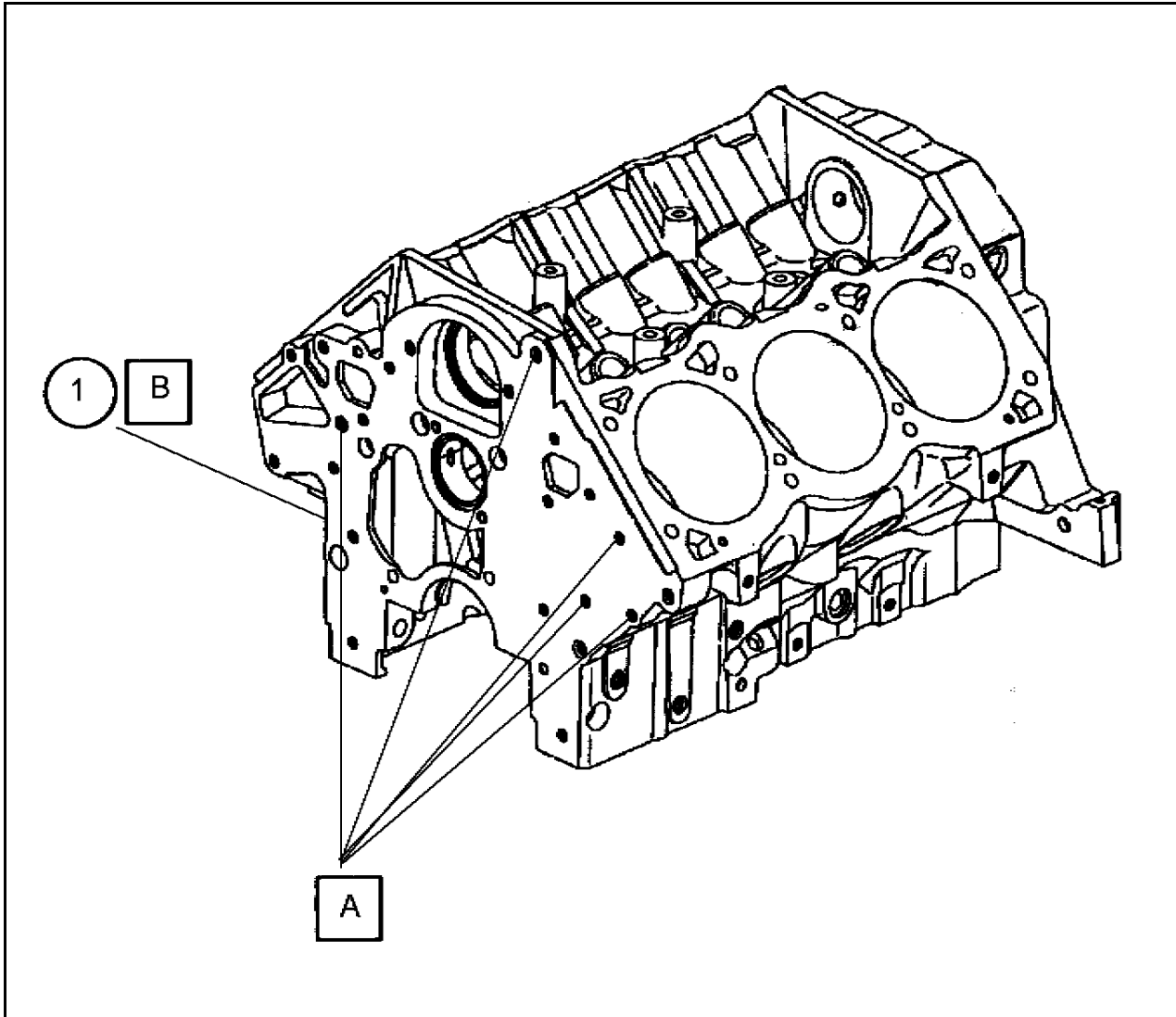

Description of Operation	
A	Install threaded fasteners with #2 Non-Hardening Permatex or Perfect Seal #4 in locations identified in view.
B	Install 1/4NPT plug in main oil gallery on the right front side of engine block.
Note: This location is not to be used for temperature control or thermocoupled.	

Specification	
1	444777 Plug Auto Hex Socket

REV	Date	Revision History
1	12/31/97	Block-3

View	
Engine Block	
New block and pre-hone prep	
Plugged holes in front of engine	

New Block and Pre-Hone Prep	Sequence III G
------------------------------------	-----------------------

Section	Sheet
1	3

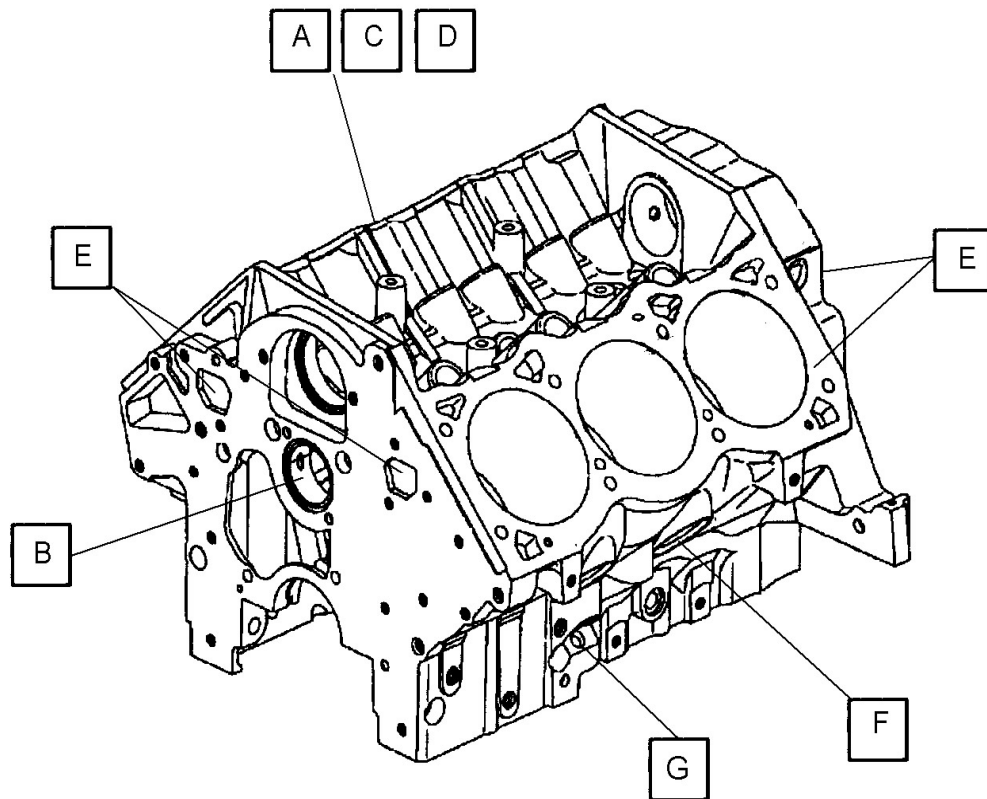

Description of Operation

- A Remove all casting slag and core sand deposits from the coolant passages on new blocks and check for core sand deposits on used blocks
- B Remove all camshaft bearings and oil gallery plugs.
- C Clean all gasket surfaces.
- D Chase all threaded holes for the main caps and cylinder head fasteners using a Class 2B Tap.
- E Remove bearings, and oil gallery plugs and main caps prior to cleaning.
- F Install coolant core plugs, GM part #24500867.
- G Ream dip stick hole using OHT3F-071-1

Specification

--	--

REV	Date	Revision History
1	12/31/97	Block-4
2	7/1/11	Revised Note E and F

View
Engine Block
New block and pre-hone prep

New Block and Pre-Hone Prep	Sequence III G
------------------------------------	-----------------------

Section	Sheet
1	4

			Description of Operation	
<p>Automatic Parts Washer Procedure for IIIIG Engine Blocks</p> <ol style="list-style-type: none"> 1) Use only NAT-50-S or PDN-50 soap at a concentration of 16 pounds of soap per 380 Liters of water. Change the cleaning solution after no more than 25 hours of use. 2) Set the temperature of the water to 140 degrees F. 3) Do not pre-condition the water that is being used in any way. 4) Prior to installing the block in the parts washer, ensure that all coolant passages are blocked off to prevent cleaning solutions from entering the passages. 5) Allow the block to run through the cleaning cycle for a period of 30 to 40 minutes. 6) After the cycle(s) are complete, immediately remove the block from the washer and spray it down with degreasing solvent. 7) Wipe cylinder bores out with a lint free towel. 8) Spray engine block with a mixture of 50/50 EF-411 and degreasing solvent. 				
			Specification	
REV	Date	Revision History	View	
1	9/5/00	Procedure for Better Engineering Jet Washer usage	Engine Block	
2	12/15/03	Update change to mineral spirits	Engine block cleaning procedure for automated type jet washers	
3	6/22/06	Update text change to degreasing solvent		
4	4/10/12	Revised the cleaning solution replacement frequency to not exceed 25 hours		
			Section	Sheet
New Block and Pre-Hone Prep		Sequence IIIIG	1	5A

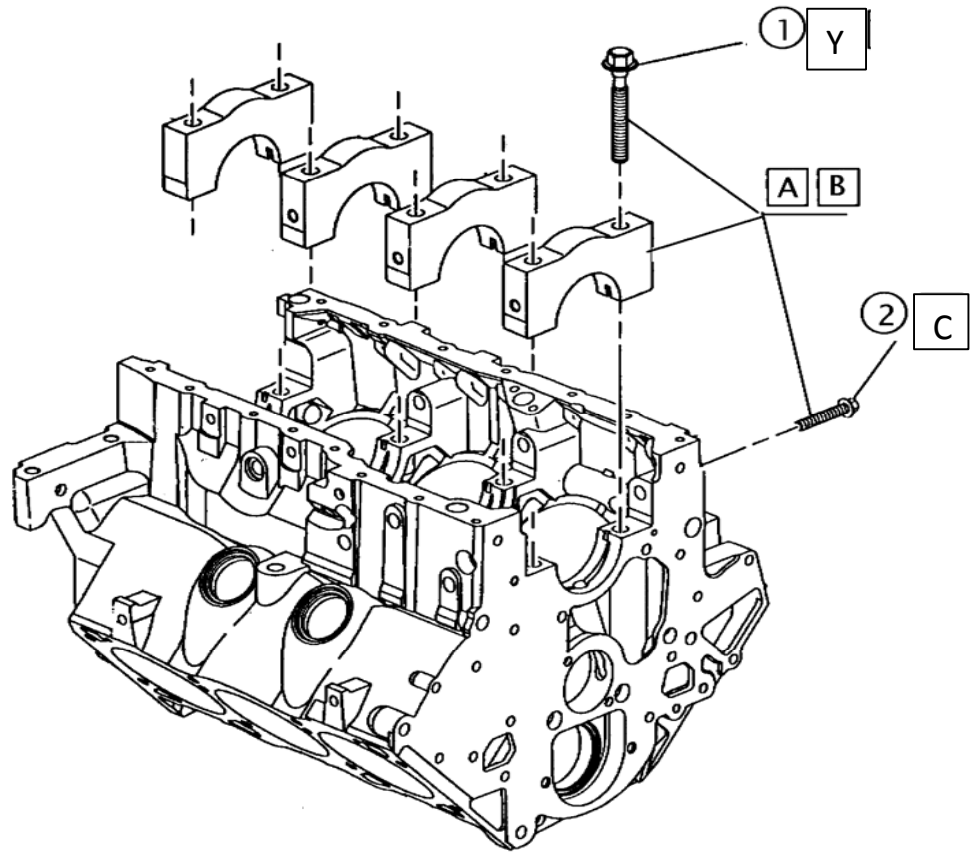

Description of Operation

- A Clean and oil all main cap fasteners (EF-411) and install main caps (use used fasteners for honing). Note: Do not use air tools to run main caps down.
- B Install main cap with fasteners as guides and draw into position with speed handle and socket in crisscross pattern.
- Y
 - 1.) Tighten all main fasteners to 70 N·m to fully seat main caps
 - 2.) Loosen the fasteners 360° counterclockwise.
 - 3.) Starting from the center of the block and moving out torque the fasteners 20 N·m, then 40 N·m
 - 4.) Starting from the center of the block and moving out for each of the steps shown below tighten fasteners in the following steps: 35°, another 35° and finally to another 35°
- C Install main cap side fasteners, torque to 15 N·m, and then an additional 45°

Specification

- 1 24503056 Bolt (8) see note Y (Tighten before Z)
- 2 24505576 Bolt (6) see note Z (Tighten after Y)

REV	Date	Revision History
1	1/10/98	Block-6
2	12/15/03	Clarification, add 40Nm + 35° 3 times... and (use used fasteners for honing) to Y2
3	6/22/06	Remove use of plastic mallet from "B"
4	7/1/11	Removed notes Y2 and Z, edited Y1 and changed to Y, edited notes A, B and C
5	4/10/12	Corrected the order of bolt installation moved note Y to before note C

View

Engine Block

Main cap installation

New Block and Pre-Hone Prep	Sequence III G	Section	Sheet
		1	6

Spray engine with 50/50
Solution EF-411 / Degreasing Solvent

A B

Coat with
EF-411

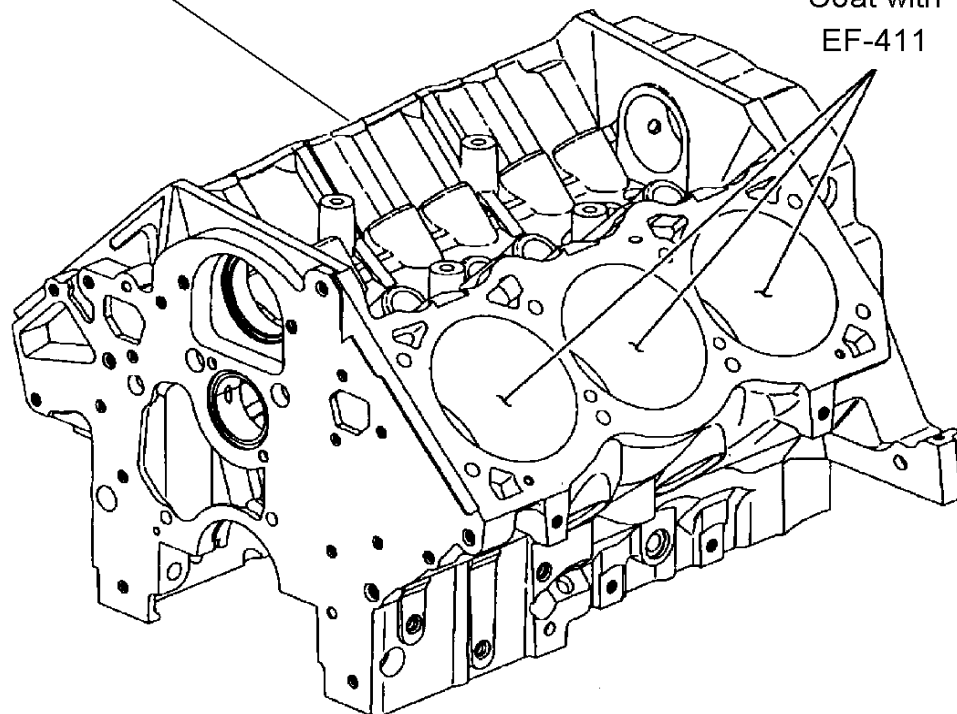

Description of Operation

- A The engine shall be cleaned using an automated washing device, however, caution should be used to prevent oxidation flash over of the ferrous surfaces. Note: Only use specified cleaning materials, refer to section 7.5 of ASTM D7320 for approved cleaning materials.
- B The block must be thoroughly cleaned using brushes through the oil galleries, camshaft tunnel, and cylinder bores with degreasing solvent to remove any detergent residue before honing.
- ? (Step Sec. 1 sheet 6)
Repeat step "A & B" above after honing.
- Note: If this is the final cleaning after honing, spray the entire engine block using a 50/50 solution of EF-411 and degreasing solvent. Air dry to remove excess solution.

Specification

--

REV	Date	Revision History
1	12/31/97	Block-5
2	12/15/03	Update, change to mineral spirits
3	6/22/06	Update change to degreasing solvent
4	7/1/11	Revised Note A

View
Engine Block
Engine block cleaning

New Block and Pre-Hone Prep	Sequence III G
------------------------------------	-----------------------

Section	Sheet
1	5

			Description of Operation	
			Specification	
			<p>1 25527831K Bolt Cyl. Head (8)(Long) Use in upper and lower position with double hardened washers on lower row. Obtain washers from B-H-J. Obtain bolts from GM Racing</p> <p>2 24503802 Gasket LH. 24503801 Gasket RH.</p>	
Revision History			View	
REV	Date		Engine Block	
1	1/1/98	Block-7	B-H-J Torque Plate installation	
2	6/22/06	Update torque wrench information		
3	3/30/07	Update fastener torquing procedure to 123Nm ± 9Nm final torque		
4	2/22/10	Updated bolt number and source, corrected head gasket part numbers		
5	7/1/11	Revised Notes A, B, C and D, Deleted Note Z		
New Block and Pre-Hone Prep		Sequence III G		
				Section
				Sheet
				1
				7

Section 2

Cylinder Block Honing

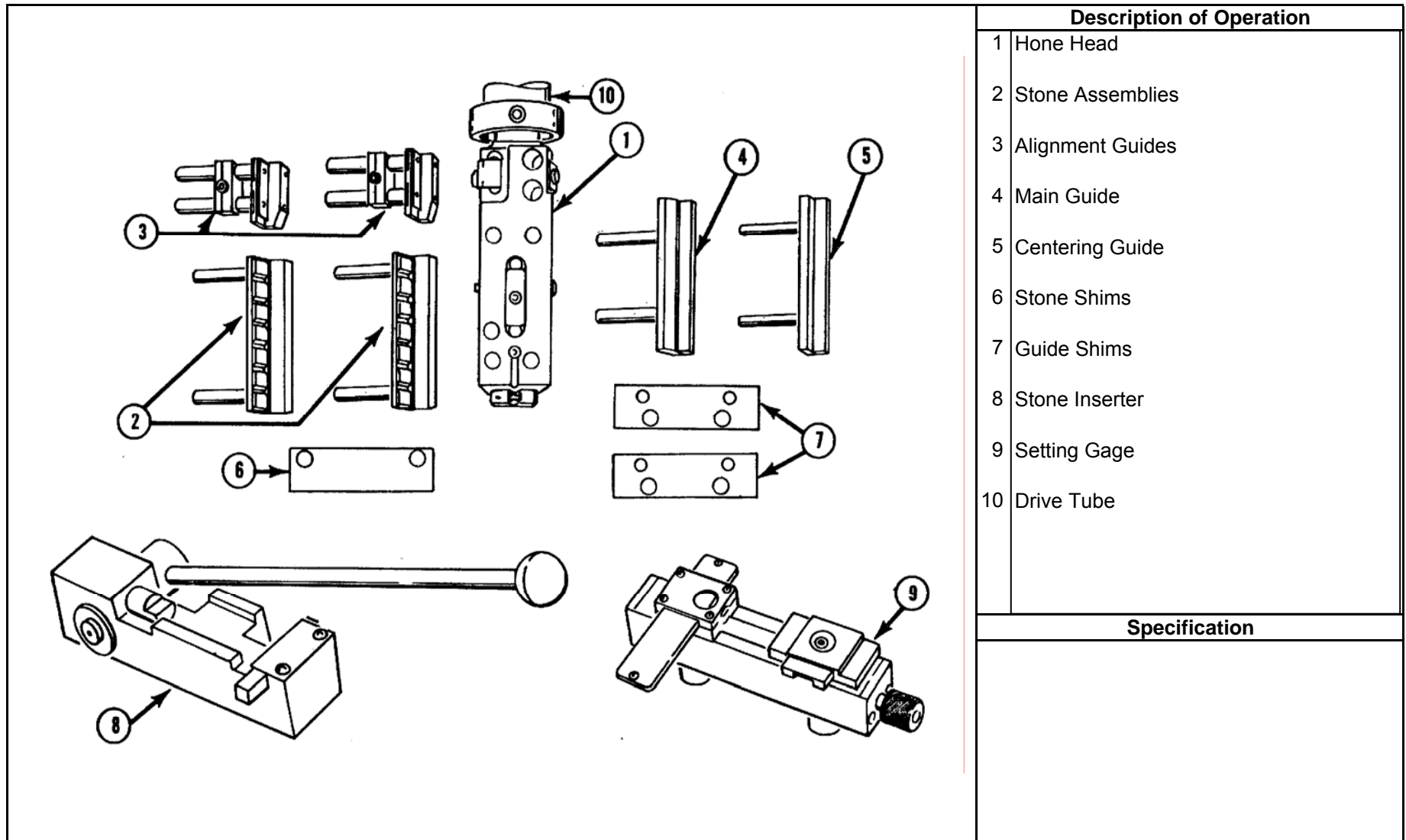

Description of Operation	
1	Hone Head
2	Stone Assemblies
3	Alignment Guides
4	Main Guide
5	Centering Guide
6	Stone Shims
7	Guide Shims
8	Stone Inserter
9	Setting Gage
10	Drive Tube

Specification	

REV	Date	Revision History
1	1/7/98	Hone-1-1

View	
Hone Unit Details	

Cylinder Honing	Sequence III G
------------------------	-----------------------

Section	Sheet
2	1

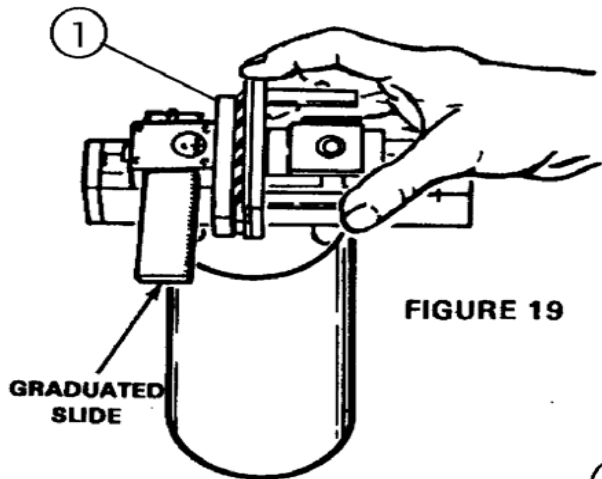

FIGURE 19

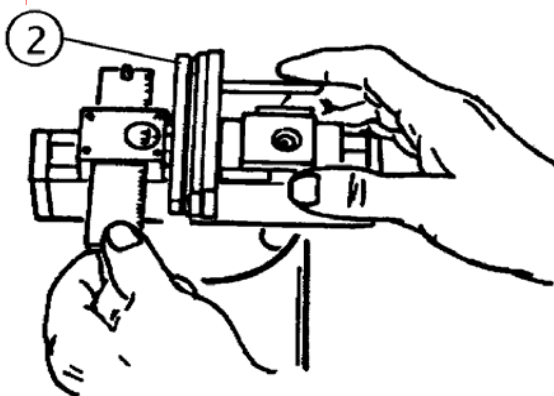

FIGURE 20

Description of Operation

Set the turret block to the standard position and adjust the setting block snugly in the cylinder bore.

19 Place the stone assembly in the setting gage with the slide scale set at "0". Add shims as necessary to adjust to 1 - 2 on the slide scale for the stone and guide assemblies.

20 Place the plateau honing tool in the setting gage with the slide scale set at "0". Add shims as necessary to adjust to 3 - 4 on the slide scale.

Note: The alignment guides are not used during honing of IIIF blocks.

Specification

- 1 EHU 512 Stone
- 2 C30-PHT-731 Plateau Honing Tool

REV	Date	Revision History
1	1/7/98	Hone-3-1 & 3-2

View
Stones & Guides
Stone and guide adjustment

Cylinder Honing	Sequence III G
------------------------	-----------------------

Section	Sheet
2	2

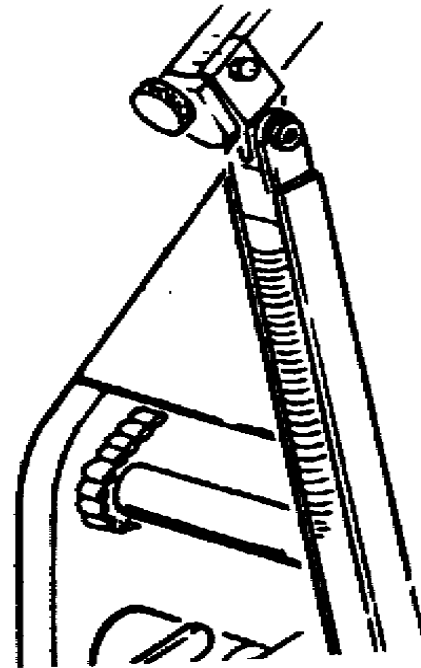
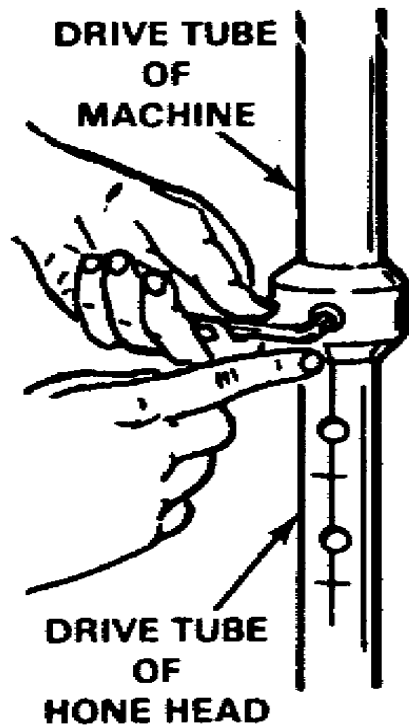

Description of Operation

Slip the Drive Tube of the Hone Head into the Drive Tube of the CV-616-46 and tighten the set screw with the first set of index marks in line.

Specification

REV	Date	Revision History
1	1/7/98	Hone-2-2

View
Drive Tube
Drive tube adjustment

Cylinder Honing

Sequence III G

Section	Sheet
2	3

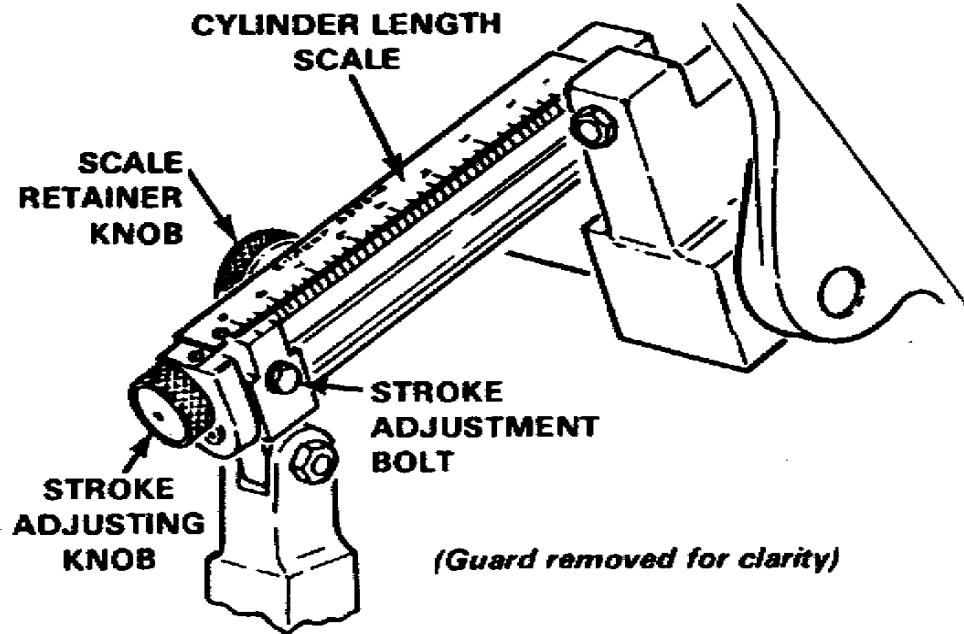

FIGURE 23

Description of Operation

Loosen stroke adjustment bolt and set stroke length at 5 3/8"

Note; to change the Stroke Scale to Metric, order PNP 1275M.

Specification

View

Stroke Length

Section

2

Sheet

4

REV	Date	Revision History
1	1/7/98	Hone-4

Cylinder Honing

Sequence III G

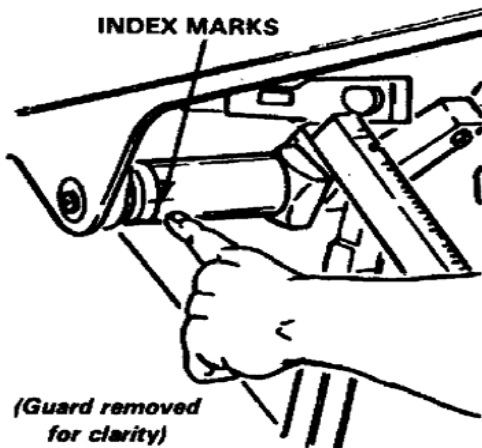

FIGURE 24

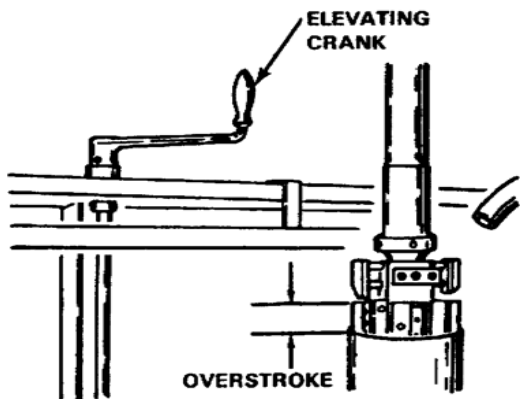

FIGURE 25

Stone Length		Top Overstroke Setting	
Inches	mm	Inches	mm
2-3/4"	70 mm	3/8"	9,5 mm
3-1/2"	89 mm	5/8"	16 mm
4-1/2"	115 mm	13/16"	21 mm
6"	152 mm	1-1/16"	27 mm

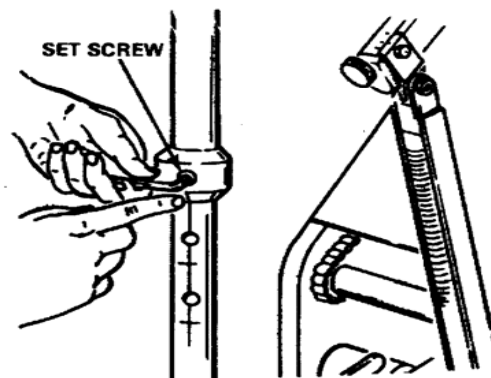

FIGURE 26

Description of Operation

With the hone head in the cylinder and the index marks lined up as shown in figure 24, use the elevating crank to adjust the overstroke length to 3/8" as indicated in figure 26 for 2 3/4" stone length.

Note: Drive tube should be set at first set of index marks.

Specification

View

Overstroke

Overstroke adjustment

Section

2

Sheet

5

REV	Date	Revision History
1	1/7/98	Hone 4 & 5

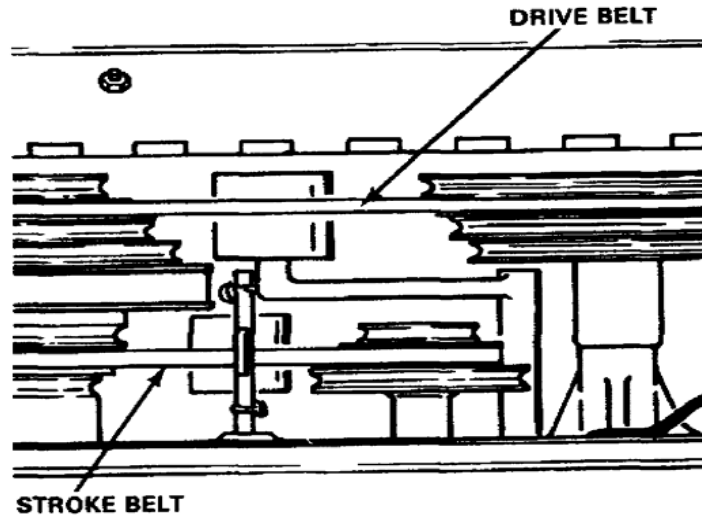
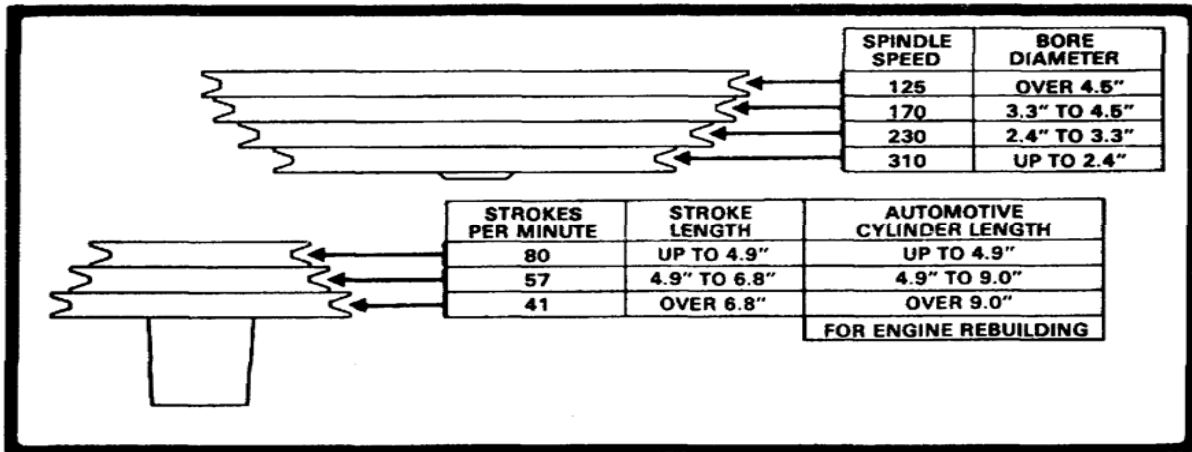

FIGURE 28

Description of Operation

Open the left side of the belt cover and set the spindle speed at 170 and the strokes per minute at 57.

Specification

View

Speed & Stroke

Section

Sheet

2

6

REV	Date	Revision History
1	1/7/98	Hone-6

Cylinder Honing

Sequence III G

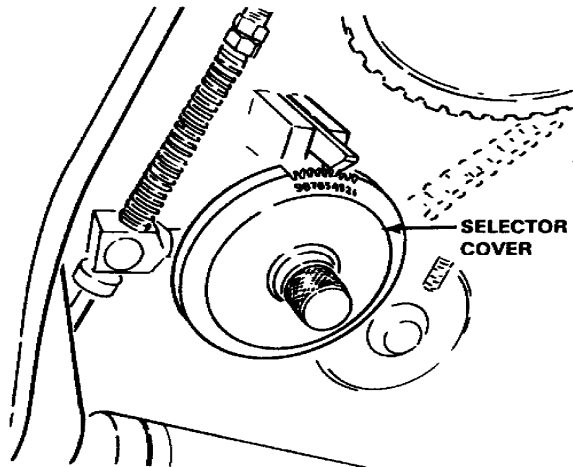

FIGURE 29

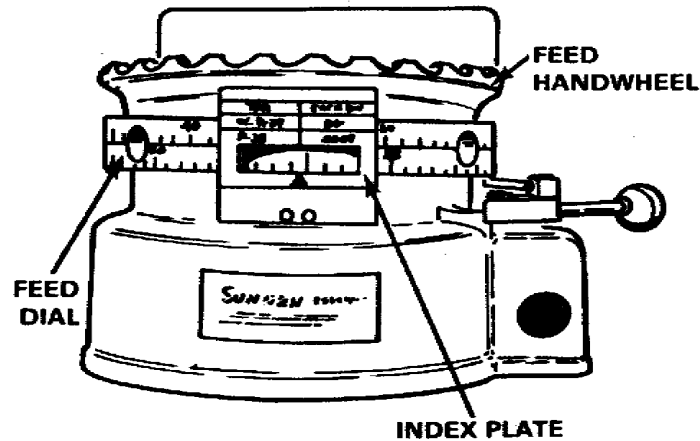

FIGURE 30

Description of Operation

Set the ratchet feed rate on the selector cover to 1 for the EHU 512 Stones. change the ratchet feed rate to 4 for the OHT3G-096-1 Plateau Hone Brushes. See figure 29

Use the index plate for the lower scale identified as P28 .005 per division.

Note: to change the Hand Wheel Assembly and Stroke Plate to Metric, order CV-215MA.

Specification

REV	Date	Revision History
1	1/7/98	Hone-7
2	12/1/99	Change note from .0005 to .005
3	12/15/03	Update ratchet feed changes for stones and brushes
4	7/1/11	Update honing brushes

View	
Ratchet Feed & Index Plate	

Cylinder Honing	Sequence III G
------------------------	-----------------------

Section	Sheet
2	7

Honing Operations Guide

EHU-512 Stones (**Ratchet Feed Set to 1**) (**Block must be at room temperature before honing**)

- 1 Insert hone head into cylinder and rotate feed handle to the left while shaking the hone head until a slight resistance is felt.
- 2 Adjust the feed dial to a point where it will not shut off the hone over fifteen strokes
- 3 Set mode switch to timed mode and set controller to 15 seconds (15 seconds = 15 strokes)
- 4 Start the hone and adjust the load to a minimum of 15 units, but not to exceed 20 units load during honing.
Apply no more than 15 strokes per cylinder at a time. (4 strokes minimum during final sizing).
Switch stone positions in the hone head between each cylinder.
Do not dwell machine when cylinder is within 0.01mm of target size.

Note 1: During final sizing, if less than 15 strokes are desired, set timer to desired seconds or operate in zero shut-off mode and never dwell machine or run less than 4 strokes / cylinder.

- 5 Follow recommended honing sequence (1,5,4,-3,2,6) do not hone adjacent cylinders
- 6 Size cylinders, 15 strokes / cylinder maximum, switching stone positions in hone head between each cylinder. Do not chase taper (dwell machine) when cylinder size is within 0.01mm of target. Stop honing with the EHU-512 stones when cylinder size is within 0.005mm of target size. Allow block to cool for fifteen minutes to confirm final size before brush honing.

OHT3G-096-1 Plateau Honing Tool (**Ratchet Feed Set to 4**)

- 1 Insert hone head into cylinder and rotate feed handle to the left while shaking the hone head until a slight resistance is felt.
- 2 Adjust feed dial so it will not shut the machine off before the control panel timer.
- 3 Set mode switch to timed mode and set controller to 45 seconds.
- 4 Start honer and increase unit load to 20 units and allow to run until system shuts off.

Note:2 Proper ratchet feed setting is required to establish desired cylinder surface parameters using the OHT3G-096-1 Plateau Hone Tool. After setting the initial load, the ratchet feed system will increase the load during the remaining time. Operators should not release load during this operation.

Description of Operation

Use LP8X-55 Chlorine free fluid set at 7L/min. flow rate. Use dual canister filtration system with honing mats CV-1100. Change filters, fluid, and mats every 15 hours of operation.

See Section 2 Sheets 10 and 11 for honer calibration and maintenance requirements.

Honing Sequence

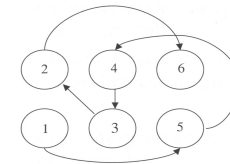

Note: When honing first run blocks, stroke limitations due not apply until cylinder size is within 0.0254mm (0.001in) of target size.

Specification

View

Fluid and Operations Guide

Section

2

Sheet

8

REV	Date	Revision History
1	1/7/98	
2	12/15/03	Update honing information according to Surveillance Panel direction 12/15/03
3	6/22/06	Update honing information according to Surveillance Panel direction 6/6/06
4	7/1/11	Addressed typos, deleted note 1 and renumberd notes 2 and 3 and clarified step 4

Cylinder Honing

Sequence III G

Cylinder Sizing Specifications

Description of Operation

First Run Target Bore Size
 Hone with EHU-512 @ 15 units load to
 Hone with C30-PHT-731 @ 20 units load for 45 sec.

Metric mm	Inch
96.52	3.8000
96.515	3.7998
96.52	3.8000

Second run Target Bore Size
 Hone with EHU-512 @ 15 units load to
 Hone with C30-PHT-731 @ 20 units load for 45 sec.

96.54	3.8008
96.535	3.8006
96.54	3.8008

Third Run Target Bore Size
 Hone with EHU-512 @ 15 units load to
 Hone with C30-PHT-731 @ 20 units load for 45 sec.

96.56	3.8016
96.555	3.8014
96.56	3.8016

Fourth Run Target Bore Size
 Hone with EHU-512 @ 15 units load to
 Hone with C30-PHT-731 @ 20 units load for 45 sec.

96.58	3.8024
96.575	3.8022
96.58	3.8024

Fifth Run Target Bore Size
 Hone with EHU-512 @ 15 units load to
 Hone with C30-PHT-731 @ 20 units load for 45 sec.

96.60	3.8031
96.595	3.8030
96.60	3.8031

Sixth Run Target Bore Size
 Hone with EHU-512 @ 15 units load to
 Hone with C30-PHT-731 @ 20 units load for 45 sec.

96.62	3.8039
96.615	3.8037
96.62	3.8039

Seventh Run Target Bore Size
 Hone with EHU-512 @ 15 units load to
 Hone with C30-PHT-731 @ 20 units load for 45 sec.

96.64	3.8047
96.635	3.8045
96.64	3.8047

Eighth Run Target Bore Size
 Hone with EHU-512 @ 15 units load to
 Hone with C30-PHT-731 @ 20 units load for 45 sec.

96.66	3.8055
96.655	3.8053
96.66	3.8055

Intent is to have finished cylinders within +/- 0.005mm (0.0002in.) of target size
Do not chase taper when cylinder size is within 0.01mm (0.0004in.) of target size
Maximum allowable taper = 0.0254mm (0.001in.)

--

Specification

--

View

Cylinder Size

--

REV	Date	Revision History
1	1/8/98	Cylinder sizing chart
2	12/15/03	Revised target load values, added target sizing and taper information
3	9/26/14	Added bore sizes for runs 7 and 8

Cylinder Honing

Sequence III G

Section	Sheet
2	9

Cylinder Sizing Specifications (continued)

Nineth Run Target Bore Size

Hone with EHU-512 @ 15 units load to

Hone with C30-PHT-731 @ 20 units load for 45 sec.

96.68	3.8063
96.675	3.8061
96.68	3.8063

Tenth Run Target Bore Size

Hone with EHU-512 @ 15 units load to

Hone with C30-PHT-731 @ 20 units load for 45 sec.

96.70	3.8071
96.665	3.8057
96.70	3.8071

Intent is to have finished cylinders within +/- 0.005mm (0.0002in.) of target size

Do not chase taper when cylinder size is within 0.01mm (0.0004in.) of target size

Maximum allowable taper = 0.0254mm (0.001in.)

Description of Operation

Specification

View

REV	Date	Revision History
1	8/4/2015	New sheet to include bore size 9 and 10

Cylinder Honing	Sequence III G	Section	Sheet
		2	9A

Honer Calibration

All CV-616 hones must be verified on-site by a using the Hydraulic Pump and Reservoir Dynamometer. All CV-616 hones should be maintained according to the attached lubrication schedule each time the fluid and filters are changed.

Contact the Test Sponsor, ASTM Test Monitoring Center, Surveillance Panel Chairman, or Operations and Hardware Subpanel Leader for information on Sunnen calibration requirements.



Description of Operation

Specification

REV		Date	Revision History	View	
1		1/1/98	Hone-10	Honer Calibration	
2		12/15/03	Update honer calibration information		
3		2/22/10	Changed "All CV-616 honers must be calibrated" to "All CV-616 honers must be verified"		
4		7/1/11	Corrected typo		
5		10/10/14	Removed the requirement for verification to be performed by a sunnen technician		
			Cylinder Honing	Sequence III G	
				Section	Sheet
				2	10

Lubrication Point Table

1	Connecting Rod Needle Bearings	#2 Grease	2 Pumps
2	Stroke Rocker Arm (two points)	#2 Grease	2 Pumps
3	Lower Drive Arm to Carriage Connecting Strap Bearing	#2 Grease	2 Pumps
4	Upper Drive Arm to Carriage Connecting Strap Bearing	#2 Grease	Remove plug from bolt and fitting. 2 pumps, and replace plug.
5	Upper Rod-feed Universal Joint	SAE 20 Oil	Coat Universal
6	One Way Roller on Solenoid Energizer Switch	SAE 20 Oil	1 Sqirt
7	Electrical Limit Shaft Bearings	SAE 20 Oil	1 Sqirt
8	Solenoid Plunger Bushing	SAE 20 Oil	1 Sqirt
9	Top of Connecting Rod where the Stroke Release Pawl rides	#2 Grease	Brush on area
10	Connecting Rod Shaft	#2 Grease	Coat
11	Stroke Release Pawl Pivots (two points)	SAE 20 Oil	1 Sqirt
12	Stroke Release Block	#2 Grease	1 Pump
13	Gear Reducer	Gear Oil 140	Drain and refill
14	Carriage Traverse Shaft (both ends)	#2 Grease	2 Pumps each
15	Carriage Traverse Shaft (two points)	SAE 20 Oil	2 Sqirts
16	Handwheel Gears (not shown)	Lubriplate Low-Temp	Remove the handwheel and repack handwheel gears.
17	Feed Pawls	SAE 20 Oil	Fill Oiler
18	Idler Arm Shafts (three points)	#2 Grease	1 Pump each
19	Gear Reducer Pully Shaft	#2 Grease	1 Pump

Description of Operation

Use LP8X-55 Chlorine free fluid set at 7 L/min. flow rate. Use dual canister filtration system with honing mats CV-1100. Change filters, fluid, and mats every 15 hours of operation.

Perform recommended lubrication as outlined in lubrication table each time the fluid and filters are changed.

See Sheet 12 for lubrication guide.

Specification

View

Honer Maintenance

Section

Sheet

2

11

Cylinder Honing

Sequence III G

REV	Date	Revision History
1	12/15/03	New sheet, Hone maintenance

			Description of Operation			
<p>FIGURE 4-1, Lubrication</p>						
			Specification			
			View			
			Lubrication Guide			
Cylinder Honing			Sequence III G		Section	Sheet
					2	12

Section 3

Short Block Assembly

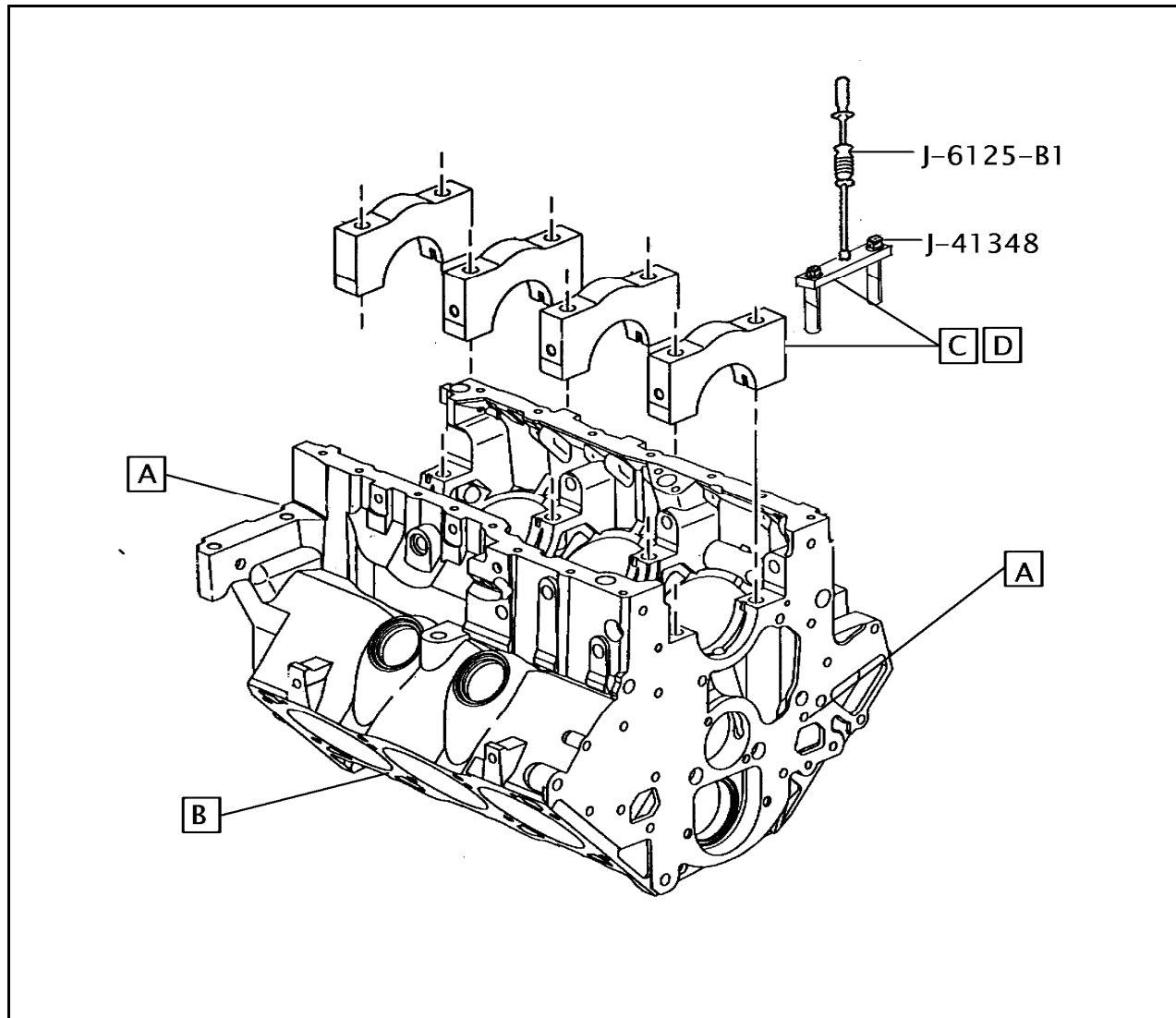

Description of Operation	
A	Remove all block off plates
B	Remove torque plates
C	Remove main cap side & main bolts.
D	Use Kent-Moore J-41348 main bearing cap puller & J-6125-1B slide hammer to remove main caps.
<p>Note: Main bearing caps are press fit. Do not hammer caps back and forth during removal. Damage to the caps may result in damage to engine bearings during test.</p>	

Specification

REV	Date	Revision History
1	01/01/98	Block-8

View	
Short Block	
Block off plate, torque plate and main cap removal	

Short Block Assembly	Sequence III G
----------------------	----------------

Section	Sheet
3	1

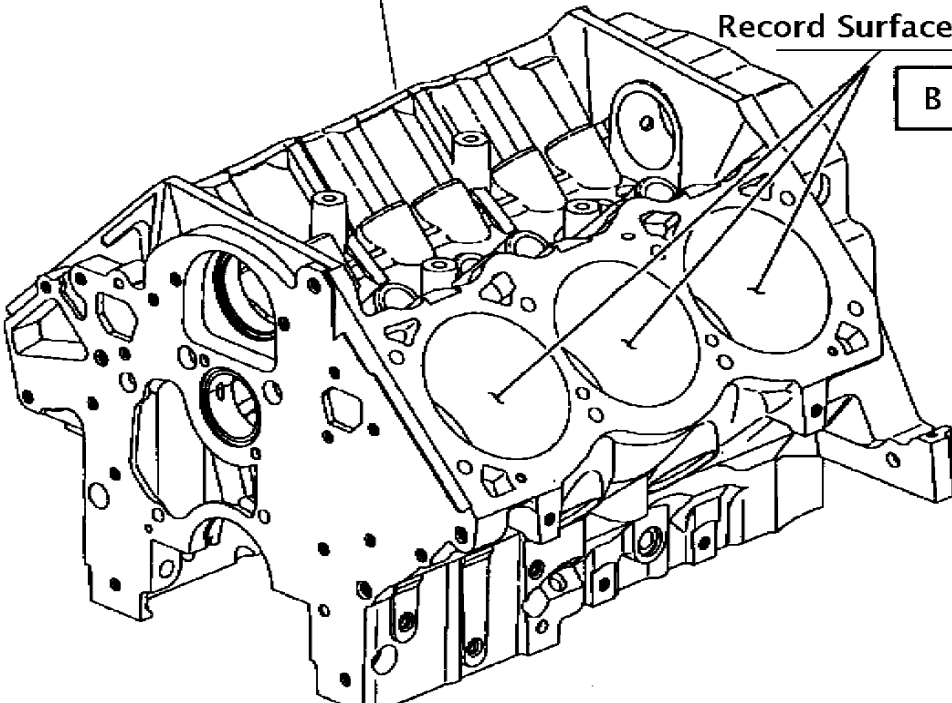
			Description of Operation	
<p style="text-align: center;"><u>Check engine block for cleanliness</u></p> <p style="text-align: center;">A</p>  <p style="text-align: center;"><u>Record Surface Finish</u></p> <p style="text-align: center;">B</p>			A	Check engine block, camshaft tunnel, lifter bores, oil galleries, gasket surfaces, and cylinder bores for cleanliness.
			B	Check and record cylinder bore surface finish Ra and confirm bore diameters / run number. The optional method is to wipe the cylinder with a lint free towel and record cylinder bore surface finish Ra and confirm bore diameters at the completion of honing. Allow the block to cool for a minimum of ten minutes before taking final bore measurements.
			C	Record appropriate data on form shown in Annex A.14 of IIIG test procedure.
			Specification	
			View	
REV	Date	Revision History	Engine block cleanliness inspection and cylinder surface finish/size recording	
1	01/02/98	Block-9		
2	06/22/06	Add item "C"		
3	07/01/11	Revised note B		
Short Block Assembly		Sequence IIIG	Section	Sheet
			3	2

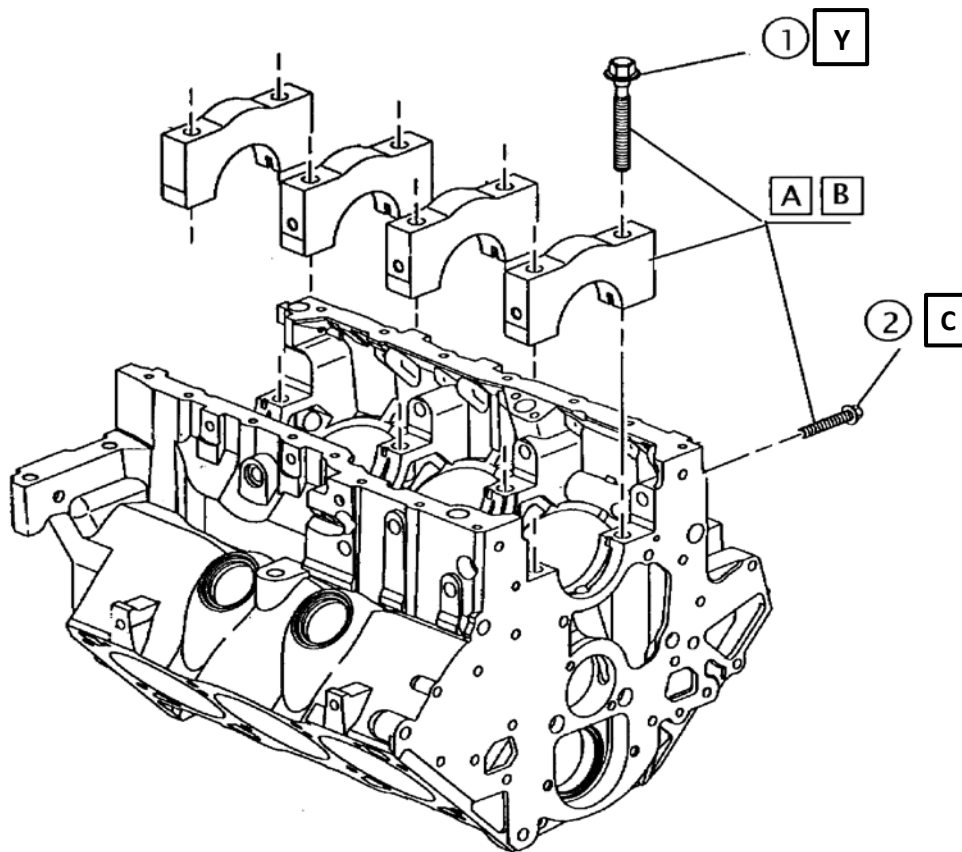

Description of Operation

- A Clean and oil all main cap fasteners (EF-411 and install main caps (use used fasteners for honing) Do not use air tools to run maincaps down
- B Install main cap with fasteners as guides and draw into position with speed handle and socket in criss cross pattern
- Y
 - 1.) Tighten all main fasteners to 70 N·m to fully seat main caps
 - 2.) Loosen fasteners 360° counterclockwise
 - 3.) Starting from the center of the block and moving out torque the fasteners 20N·m then 40N·m
 - 4.) Starting from the center of the block and moving out for each of the steps show below tighten fasteners in the following steps: 35°, another 35° then finally to another 35°.
- C Install main cap side fasteners, torque to 15 N·m, then an additional 45°

Specification

- 1 24503056 Bolt (8) see note Y (Tighten before Z)
- 2 24505576 Bolt (6) see note Z (Tighten after Y)

REV	Date	Revision History
1	7/1/11	Added as Sheet 3
1	4/10/12	Revised order of main bolt installation
New Block and Pre-Hone Prep		Sequence IIIG

View	
Engine Block	
Main cap installation	
Section	Sheet
3	3

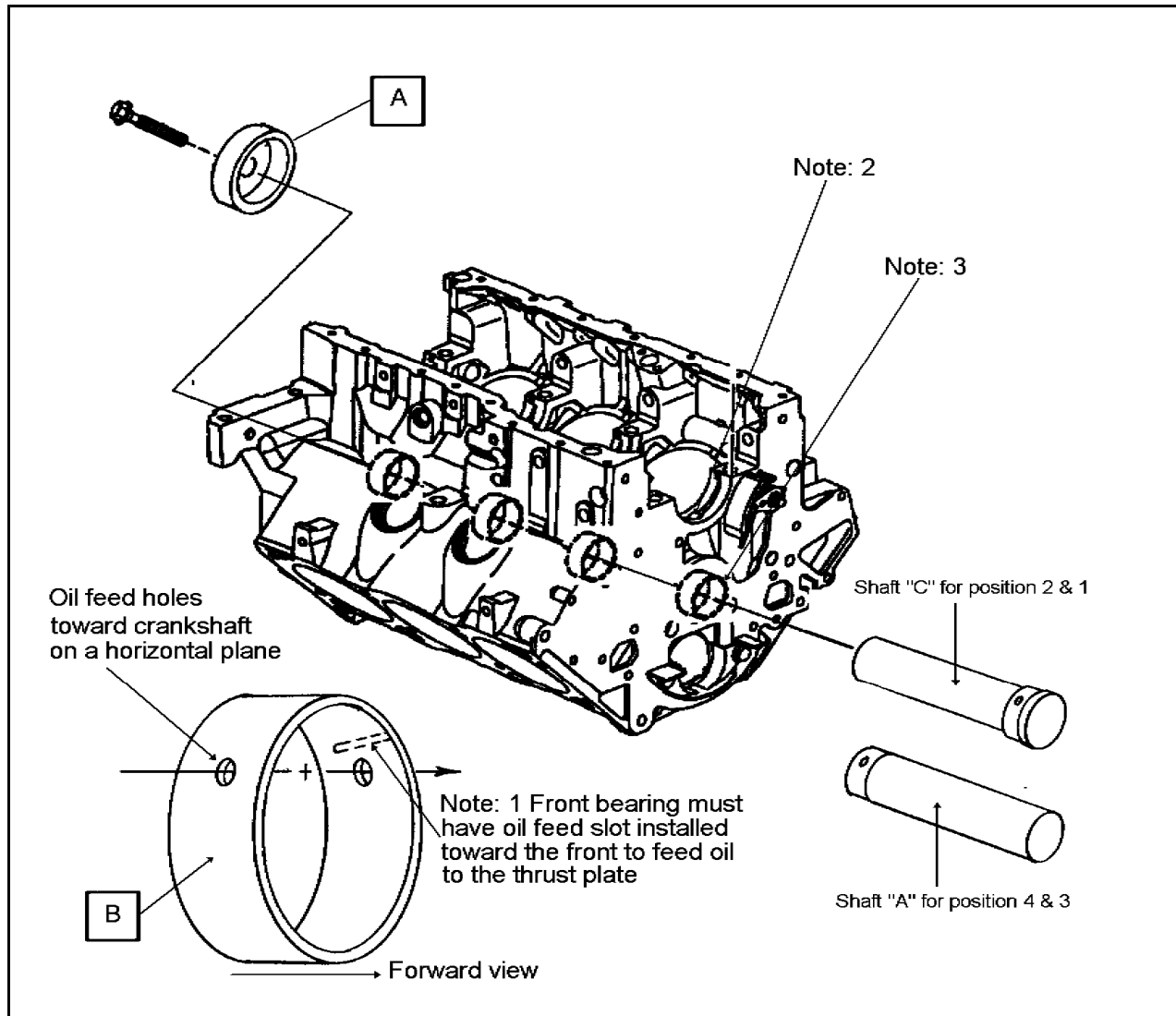

Description of Operation

A Install camshaft bearings using OHT3F-019-1 camshaft bearing installation tool, Sections:
 A for #4 rear & #3 intermediate
 C for #2 intermediate & #1 front

B Lubricate bearing bore and bearing OD with EF-411. Install bearings with the oil feed holes positioned toward the crankshaft on a horizontal plane. See view "B" and Note: 1

Note: 2
 Use a light pen to check the intersection of oil feed hole when viewed through main bearing oil gallery

Note:3
 Check bearing bores to remove sharp edge or burrs in leading edge and/or bore before installation. See Sec.1 Sheet 2

Specification

1	Bearing camshaft #1 & #4 OHT3F-028-09
2	Bearing camshaft #2 & #3 OHT3F-028-10 Both bearings are included in OHT3F-042-2

REV	Date	Revision History
1	01/02/98	Block-10
2	07/01/11	Renumbered as sheet 4

View	
Short Block	
Camshaft bearing positioning and installation	

Short Block Assembly	Sequence III G
-----------------------------	-----------------------

Section	Sheet
3	4

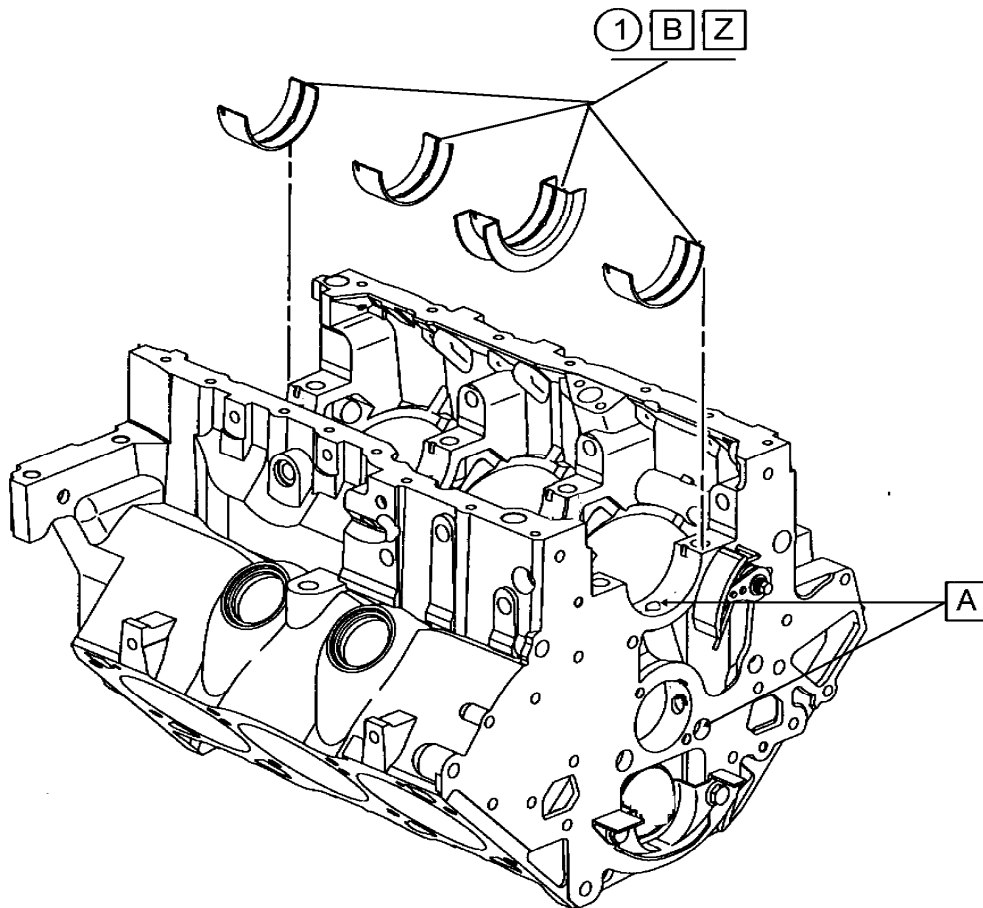

Description of Operation

- A Using compressed air, blow through each oil gallery feed from the main bearing support through the camshaft bearings to dislodge any babbitt material that might have come off the camshaft bearings during installation. Use an inspection light to ensure proper alignment of the camshaft bearings and that all debris has been removed from the main and lifter oil galleries.
- B Check the upper main bearing bores for cleanliness and install the upper main bearings in the engine block.
- Z Lubricate with EF-411

Specification

- 1 OHT3F-042-2
- OH-101 (1,3,4, Upper)
- OH-102 (1,3, Lower)
- OH-103 (4 Lower)
- OH-104 (2 Lower)
- OH-105 (2 Upper)

REV	Date	Revision History
1	01/03/98	Block-11
2	07/01/11	Renumbered as sheet 5

View
Short Block
Upper main bearing inspection and installation

Short Block Assembly	Sequence III G
-----------------------------	-----------------------

Section	Sheet
3	5

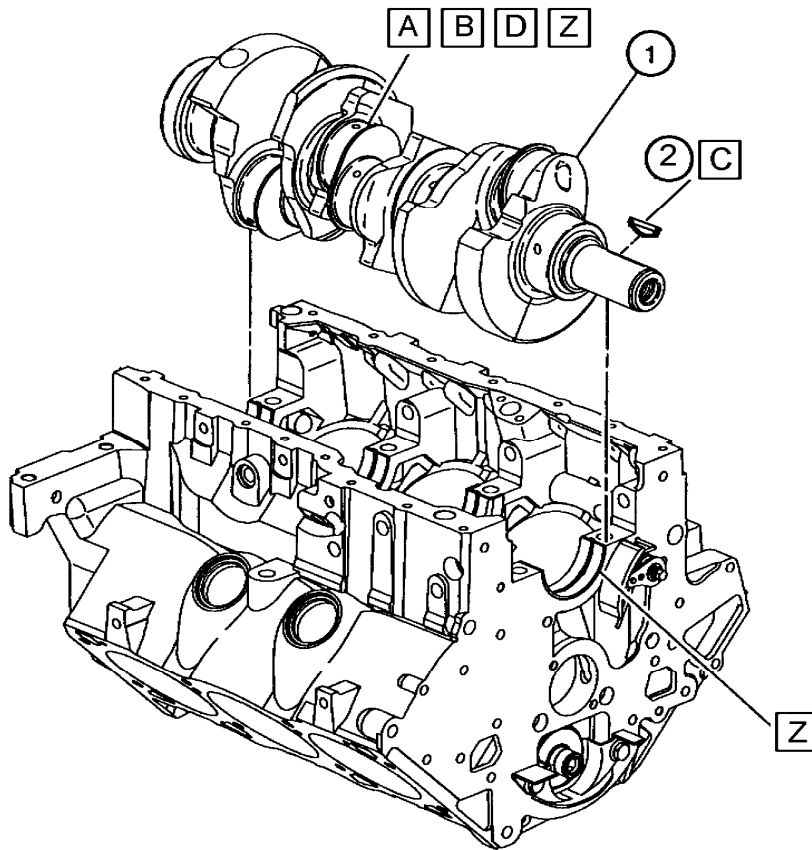

Description of Operation

- A Clean the crankshaft using an approved commercial cleaning agent followed by degreasing solvent and Mylar strip polishing cloth (use Mylar polishing cloth only if journals are nicked or oxidized, Do Not use to remove varnish).
- B Check journal diameters.
Mains 63.470 - 63.495 mm
Rods 57.1170 - 57.1475 mm
- C Install key
- D Install crankshaft in engine block using care to not move the upper main bearings.
- Z Lubricate with EF-411

Specification

- 1 24502168 Crankshaft
 - 2 12563282 Key
- Mylar Tape
Q135 Metalite 3µ 1½ wide roll

View

Short Block

Crankshaft cleaning, inspection, and installatio

Section

3

Sheet

6

REV	Date	Revision History
1	01/03/98	Block-12
2	12/01/04	Change to mineral spirits
3	06/22/06	Update text, add mylar tape part number, change key from (25534912 to 12563282)
4	07/01/11	Renumbered as sheet 6

Short Block Assembly

Sequence III G

Use new fasteners for each test. Wire wheel sealer from under side of fastener head. Do not wire wheel threads.

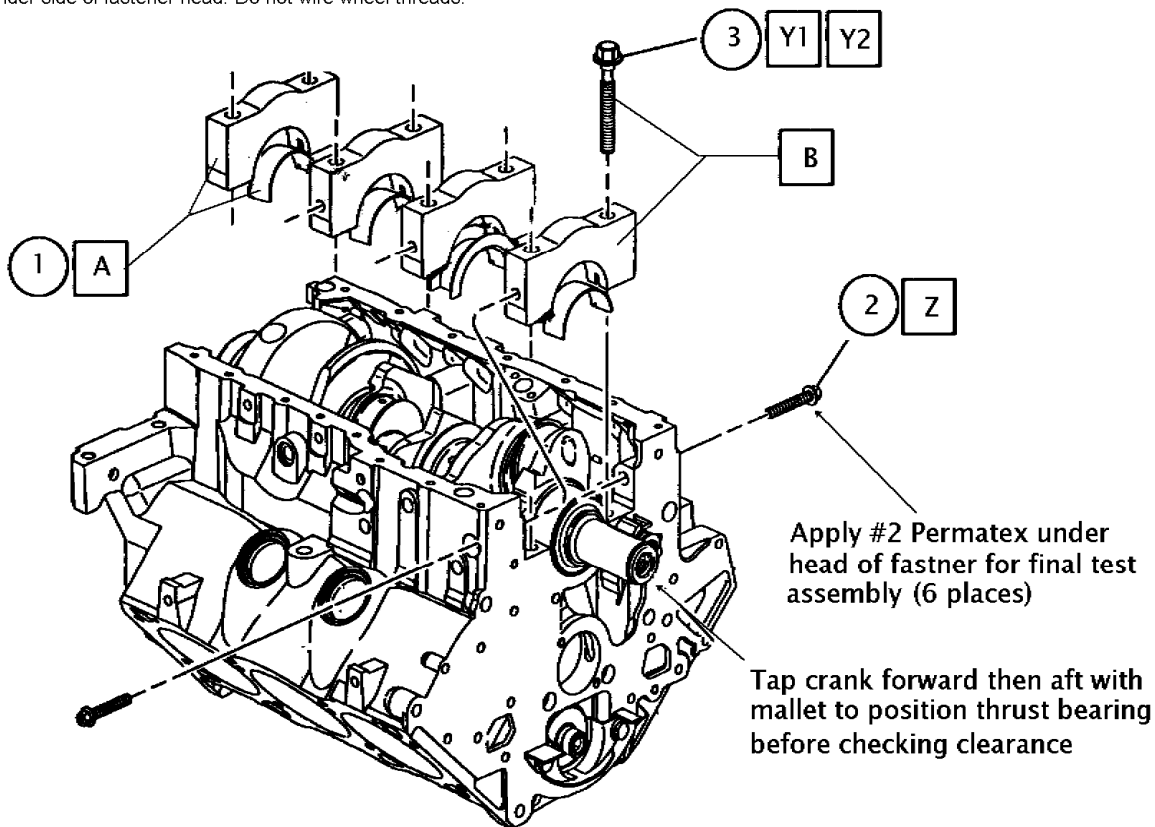

Description of Operation

- A Install lower main bearings into main caps.
- B Install main cap with new fasteners, oil all main cap fasteners (EF-411) and as guides and draw into position using very light pressure by hand with speed handle and socket in crisscross pattern.
- C Install main cap side bolts
- Y1 Tighten all main bolts to 70 Nm to fully seat main caps and then loosen the bolts 360° counterclockwise. Tap crankshaft with mallet to position thrust bearing.*
- Y2 Torque & Angle 20Nm then 40Nm + 35°+35°+35° (repeat 3 times from center out) Check crankshaft end play 0.076 - 0.279mm
- Y3 Torque & Angle 15Nm + 45° (See note on sealer usage)

Specification

- 1 OHT3F-042-2 Bearing kit
- 2 24505576 Bolt side (6)
See note on sealer usage
- 3 24503056 Bolt main cap (8)

REV	Date	Revision History
1	01/10/98	Block-13
2	06/22/06	Update view, fastener usage and prep, also clearance spec.
3	02/22/10	Update view, fastener usage and prep.
4	07/01/11	Renumbered as sheet 7 and revised note B

View
Short Block
Lower main bearing and crankshaft final test installation

Short Block Assembly	Sequence III G
-----------------------------	-----------------------

Section	Sheet
3	7

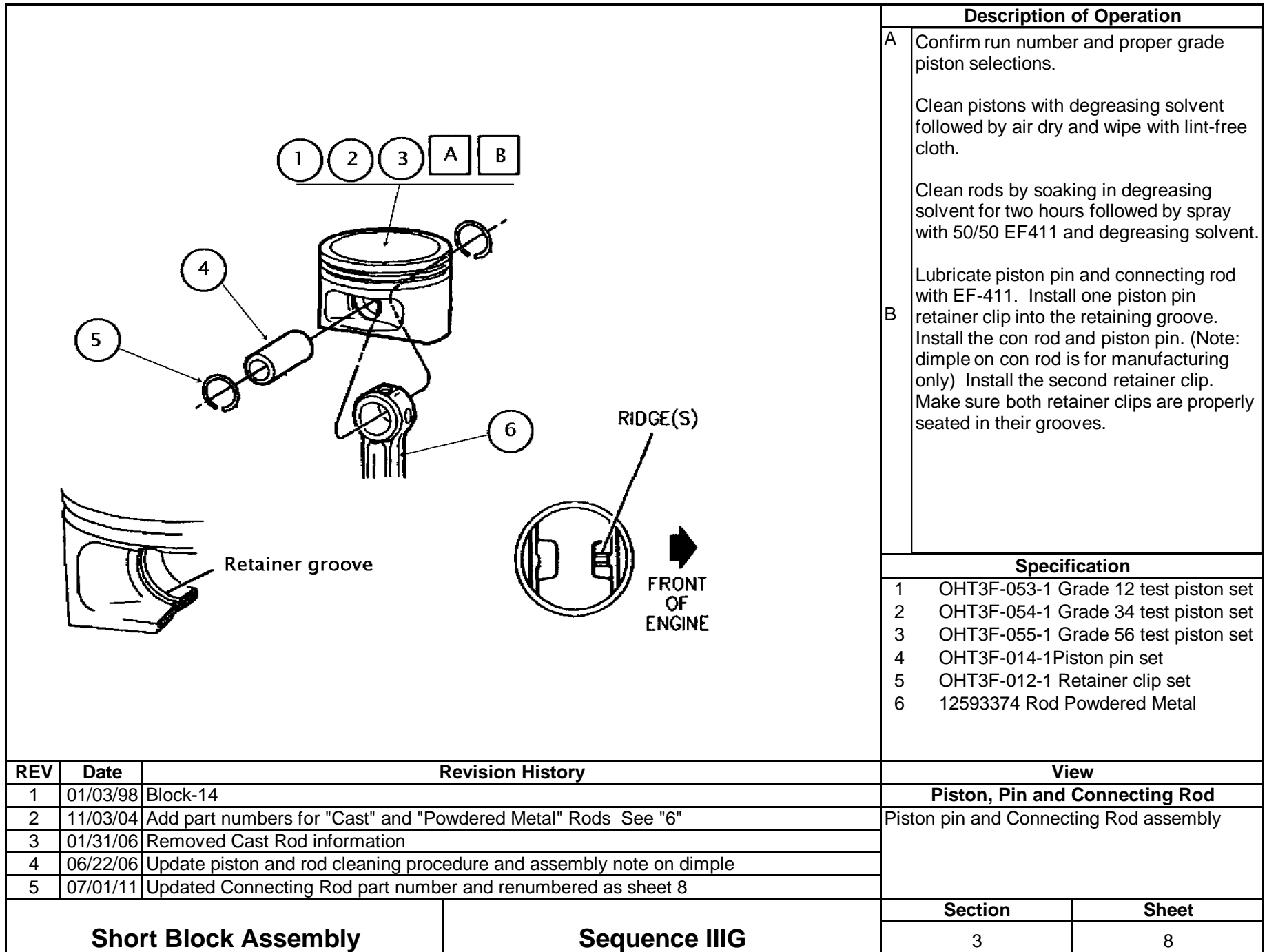

Description of Operation	
A	<p>Confirm run number and proper grade piston selections.</p> <p>Clean pistons with degreasing solvent followed by air dry and wipe with lint-free cloth.</p> <p>Clean rods by soaking in degreasing solvent for two hours followed by spray with 50/50 EF411 and degreasing solvent.</p> <p>Lubricate piston pin and connecting rod with EF-411. Install one piston pin retainer clip into the retaining groove.</p>
B	<p>Install the con rod and piston pin. (Note: dimple on con rod is for manufacturing only) Install the second retainer clip. Make sure both retainer clips are properly seated in their grooves.</p>

Specification	
1	OHT3F-053-1 Grade 12 test piston set
2	OHT3F-054-1 Grade 34 test piston set
3	OHT3F-055-1 Grade 56 test piston set
4	OHT3F-014-1Piston pin set
5	OHT3F-012-1 Retainer clip set
6	12593374 Rod Powdered Metal

REV	Date	Revision History
1	01/03/98	Block-14
2	11/03/04	Add part numbers for "Cast" and "Powdered Metal" Rods See "6"
3	01/31/06	Removed Cast Rod information
4	06/22/06	Update piston and rod cleaning procedure and assembly note on dimple
5	07/01/11	Updated Connecting Rod part number and renumbered as sheet 8

View	
Piston, Pin and Connecting Rod	
Piston pin and Connecting Rod assembly	

Short Block Assembly	Sequence III G
-----------------------------	-----------------------

Section	Sheet
3	8

**Sequence IIIG
Piston, Cylinder Bore & Ring Gap Information**

Piston Grade / Run	Target Bore Size	Master Ring Gage	Target Ring Gap		Piston Size
			Top	2nd	
12 / 1	96.52	96.53	0.635	1.067	96.482 - 96.497
12 / 2	96.54	96.53	0.635	1.067	96.482 - 96.497
34 / 3	96.56	96.57	0.635	1.067	96.522 - 96.537
34 / 4	96.58	96.57	0.635	1.067	96.522 - 96.537
56 / 5	96.60	96.61	0.635	1.067	96.562 - 96.577
56 / 6	96.62	96.61	0.635	1.067	96.562 - 96.577
78 / 7	96.64	96.65	0.635	1.067	96.602 - 96.617
78 / 8	96.66	96.65	0.635	1.067	96.602 - 96.617
90 / 9	96.68	96.69	0.635	1.067	96.6420 - 96.657
90 / 10	96.70	96.69	0.635	1.067	96.6420 - 96.657

ASTM SEQUENCE IIIG RING COLOR CODE MARKINGS BY ENGINE RUN

RUN	OHT PART NUMBER	DESCRIPTION	COLOR	STRIPE(S)
1	3G050-TOP 1 3G050-SECOND 1	TOP RING SECOND RING	PINK YELLOW	ONE (1) ONE (1)
2	3G050-TOP 2 3G050-SECOND 2	TOP RING SECOND RING	PINK YELLOW	TWO (2) TWO (2)
3	3G051-TOP 3 3G051-SECOND 3	TOP RING SECOND RING	PINK YELLOW	THREE (3) THREE (3)
4	3G051-TOP 4 3G051-SECOND 4	TOP RING SECOND RING	BROWN GREEN	ONE (1) ONE (1)
5	3G052-TOP 5 3G052-SECOND 5	TOP RING SECOND RING	BROWN GREEN	TWO (2) TWO (2)
6	3G052-TOP 6 3G052-SECOND 6	TOP RING SECOND RING	BROWN GREEN	THREE (3) THREE (3)
7	3G053-TOP 7 3G053-SECOND 7	TOP RING SECOND RING	BLUE WHITE	ONE (1) ONE (1)
8	3G053-TOP 8 3G053-SECOND 8	TOP RING SECOND RING	BLUE WHITE	TWO (2) TWO (2)
9	3G054-TOP 9 3G054-SECOND 9	TOP RING SECOND RING	BLUE WHITE	THREE (3) THREE (3)
10	3G054-TOP 10 3G054-SECOND 10	TOP RING SECOND RING	LT GREEN LT GREY	ONE (1) ONE (1)

NOTE: PAINT IDENTIFICATION MUST BE REMOVED FROM RING

Description of Operation

Confirm correct ring grade and gaps for the engine run / piston grade. No piston ring gap adjustments are allowed.

To check ring gap, use Starrett Taper Gage #270 and measure the gap in the finished cylinder bore

Specification

- 1 OHT3G-050-RN1-1
- 2 OHT3G-050-RN2-1
- 3 OHT3G-051-RN3-1
- 4 OHT3G-051-RN4-1
- 5 OHT3G-052-RN5-1
- 6 OHT3G-052-RN6-1
- 7 OHT3G-053-RN7-1
- 8 OHT3G-053-RN8-1
- 9 OHT3G-053-RN9-1
- 10 OHT3G-053-RN10-1

View

Piston Ring

Piston ring installation and clearance

Section

Sheet

3

9

REV	Date	Revision History
1	06/18/02	IIIG Block-15
2	4/28/03	Update color coding
3	09/10/03	Correct top ring gap typo from 0.064 to 0.635mm
4	06/22/06	Expand drawings and add section 3 sheet 8A for additional information
5	02/22/10	Deleted OHT ring gages and allowed measurement in cylinder block
6	04/10/12	Revised target bore size for 12/2 piston and updated ring part numbers
7	09/26/14	Added part numbers, color codes and target bore sizes for 7/8 pistons
8	08/03/15	Added part numbers, color codes and target bore sizes for 9/10 pistons

Short Block Assembly

Sequence IIIG

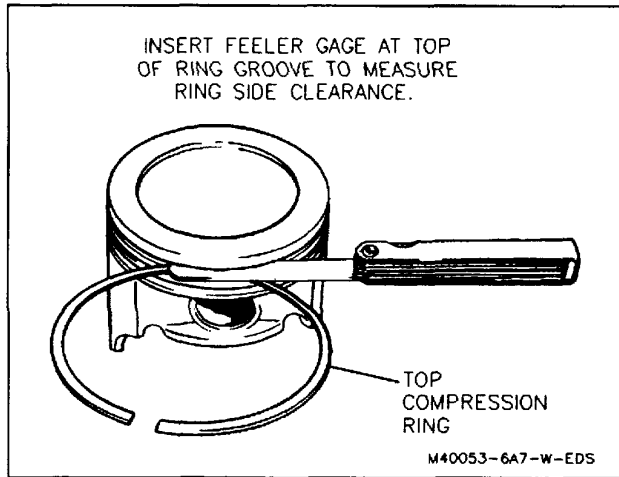

Figure 69 - Measuring Piston Ring Side Clearance

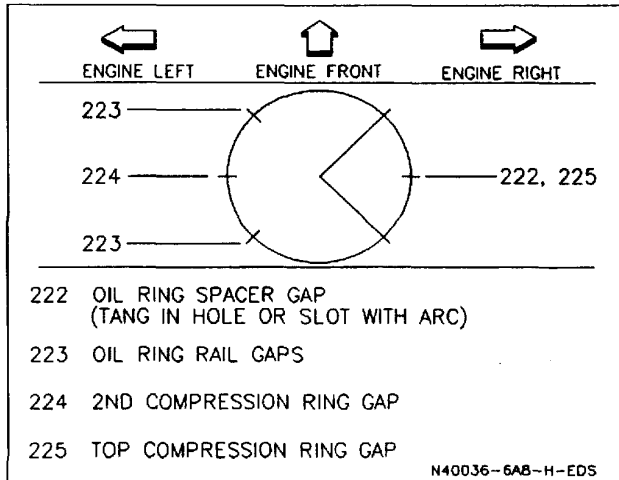
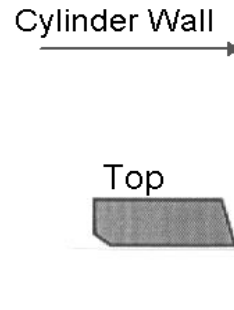

Figure 64 - Piston Ring Gap Location



Note: BC-6 second ring does not have an identification mark for top. Second ring must be installed with the sharp edge of the taper face down toward the bottom of the piston as shown in view.

Description of Operation

Check for proper ring side clearance.
 Top & 2nd. 0.033 - 0.079mm
 Oil control 0.023 - 0.201mm

Position rings on piston according to ring gap stagger chart. Orientation of second ring must be taper down as shown in view. Although orientation of oil control ring rails and expander are unidirectional, install the oil ring expanders with the gaps facing up.

Lubricate assembly with EF-411

Specification

View

Piston ring installation, orientation, and clearance information

Section

3

Sheet

9A

Short Block Assembly

Sequence III G

REV	Date	Revision History
1	6/22/06	Ring orientation
2	7/1/11	Removed BC-6 from piston orientation and added orientation for oil ring expander
		Renumbered as 9A

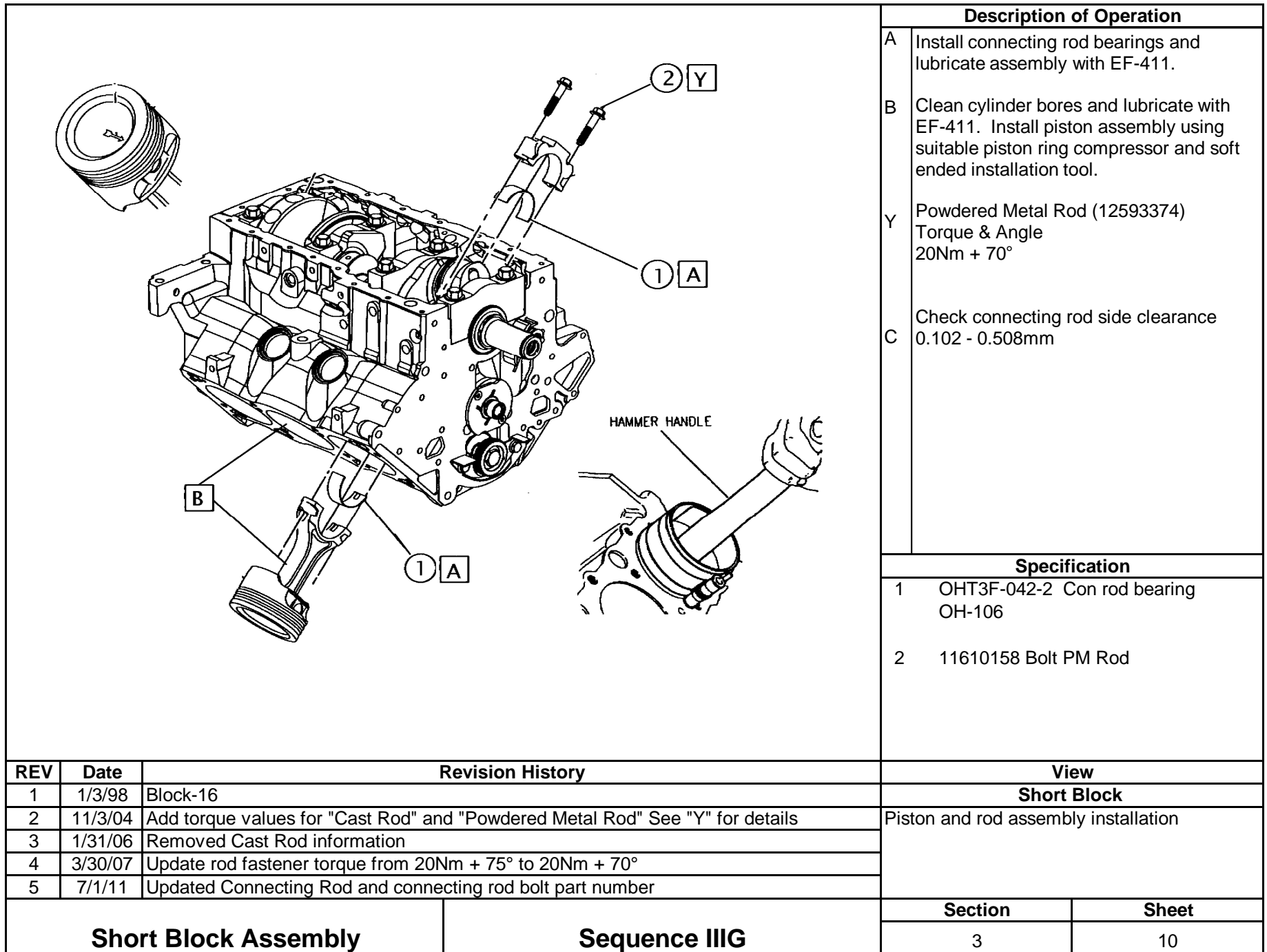

Description of Operation	
A	Install connecting rod bearings and lubricate assembly with EF-411.
B	Clean cylinder bores and lubricate with EF-411. Install piston assembly using suitable piston ring compressor and soft ended installation tool.
Y	Powdered Metal Rod (12593374) Torque & Angle 20Nm + 70°
C	Check connecting rod side clearance 0.102 - 0.508mm

Specification	
1	OHT3F-042-2 Con rod bearing OH-106
2	11610158 Bolt PM Rod

REV	Date	Revision History
1	1/3/98	Block-16
2	11/3/04	Add torque values for "Cast Rod" and "Powdered Metal Rod" See "Y" for details
3	1/31/06	Removed Cast Rod information
4	3/30/07	Update rod fastener torque from 20Nm + 75° to 20Nm + 70°
5	7/1/11	Updated Connecting Rod and connecting rod bolt part number

View	
Short Block	
Piston and rod assembly installation	

Short Block Assembly	Sequence III G
-----------------------------	-----------------------

Section	Sheet
3	10

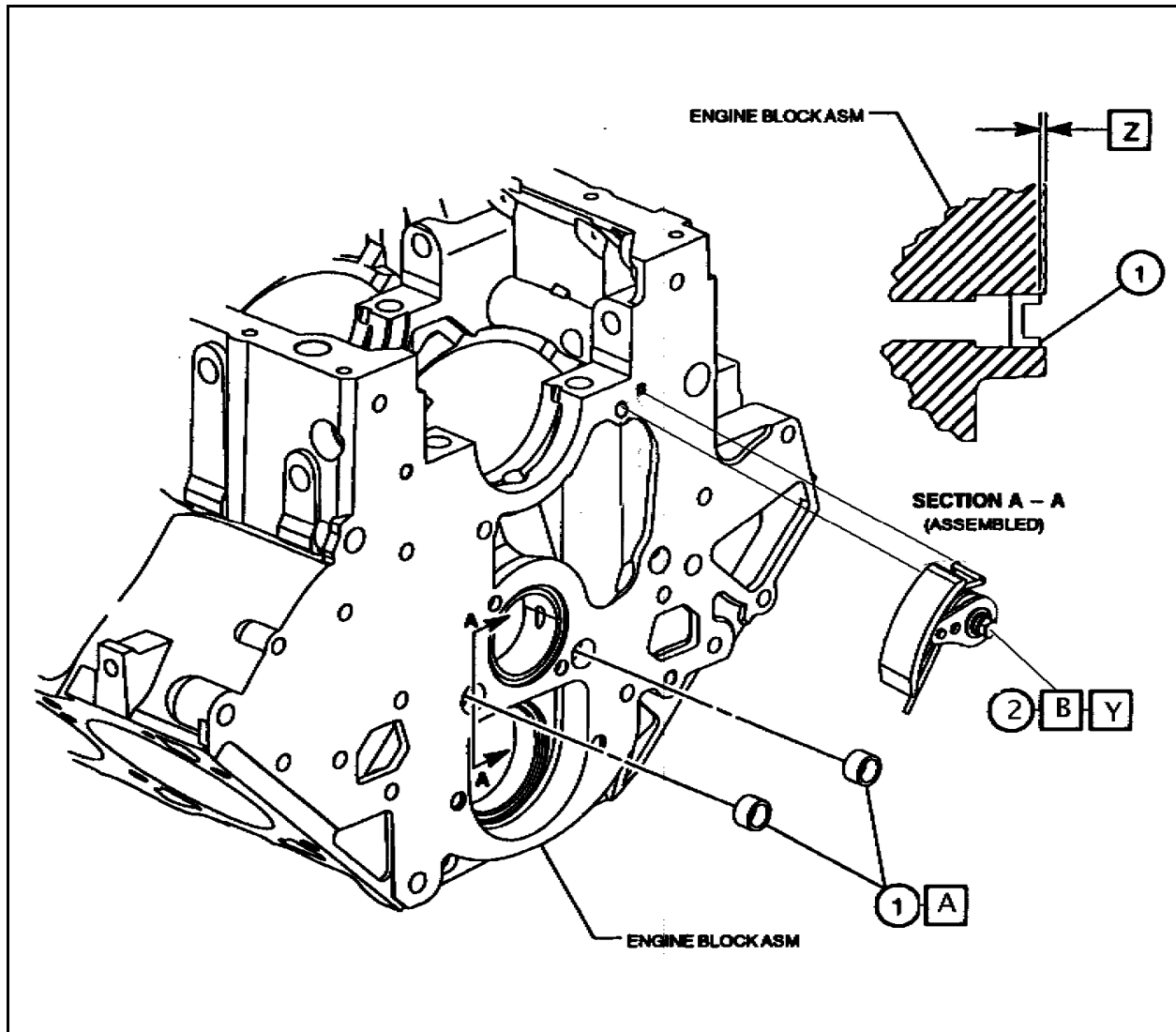

Description of Operation	
A	Install oil gallery plugs, see cross section A - A.
B	Install damper assembly
Y	Torque 22Nm
Z	Locate cup plug 1.5 +/- 0.75mm below front face of block.

Specification	
1	3835577 Plug, oil gallery
2	24503893 Damper assembly

REV	Date	Revision History
1	1/3/98	Block-17
2	7/1/11	Renumbered as sheet 11

View	
Short Block	
Oil gallery plugs and timing chain damper	

Short Block Assembly	Sequence III G
-----------------------------	-----------------------

Section	Sheet
3	11

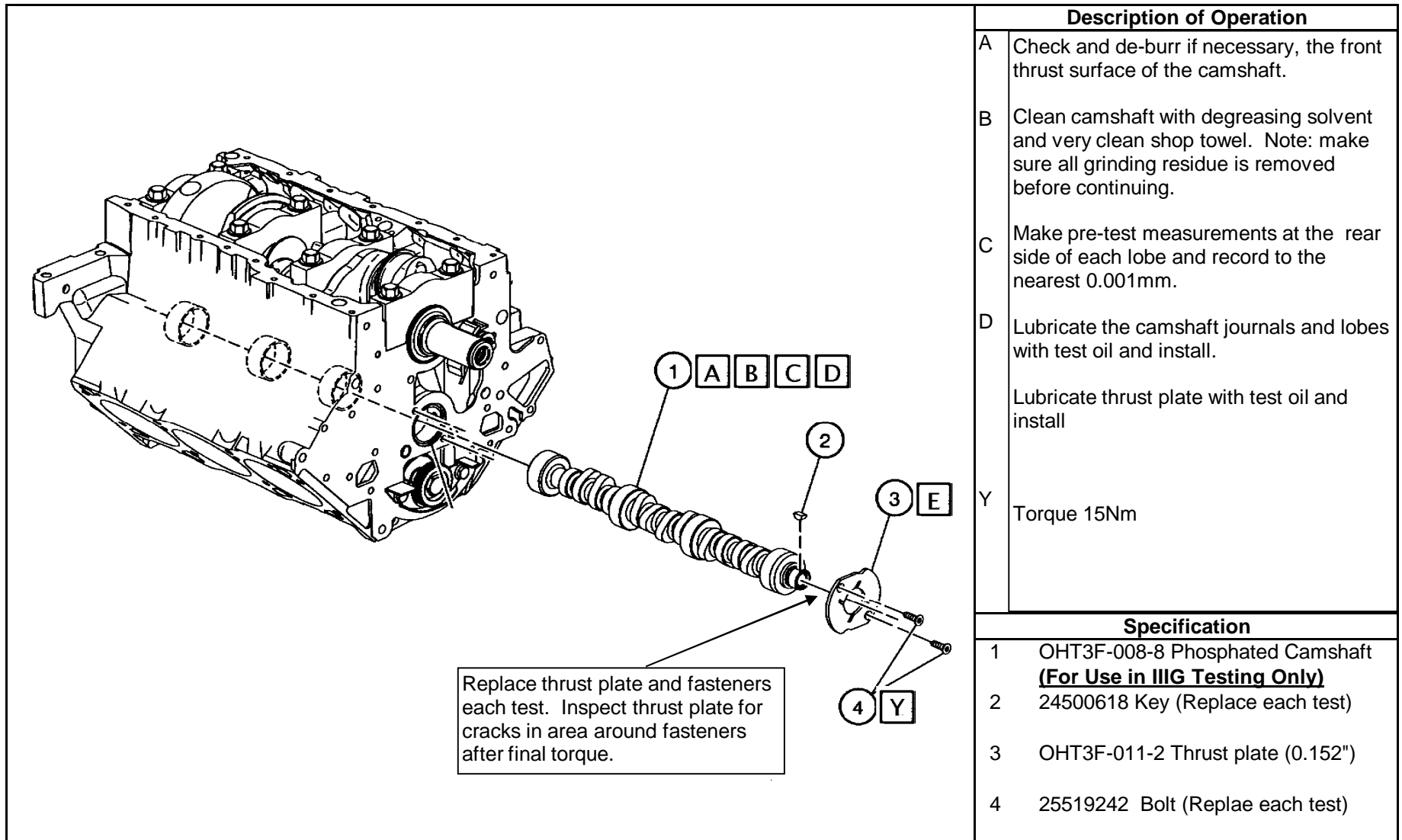

Description of Operation	
A	Check and de-burr if necessary, the front thrust surface of the camshaft.
B	Clean camshaft with degreasing solvent and very clean shop towel. Note: make sure all grinding residue is removed before continuing.
C	Make pre-test measurements at the rear side of each lobe and record to the nearest 0.001mm.
D	Lubricate the camshaft journals and lobes with test oil and install. Lubricate thrust plate with test oil and install
Y	Torque 15Nm

Specification	
1	OHT3F-008-8 Phosphated Camshaft (For Use in IIIG Testing Only)
2	24500618 Key (Replace each test)
3	OHT3F-011-2 Thrust plate (0.152")
4	25519242 Bolt (Replae each test)

REV	Date	Revision History
1	1/13/98	Block-18
2	12/1/04	Change to mineral spirits
3	6/22/06	Update usage information
4	3/30/07	Update "D" pre-test lubrication directions
5	7/1/11	Update "D" pre-test lubrication directions, renumbered as sheet 12

Short Block Assembly	Sequence IIIG	Section	Sheet
		3	12

Short Block	
Camshaft cleaning, measurement, and installation	

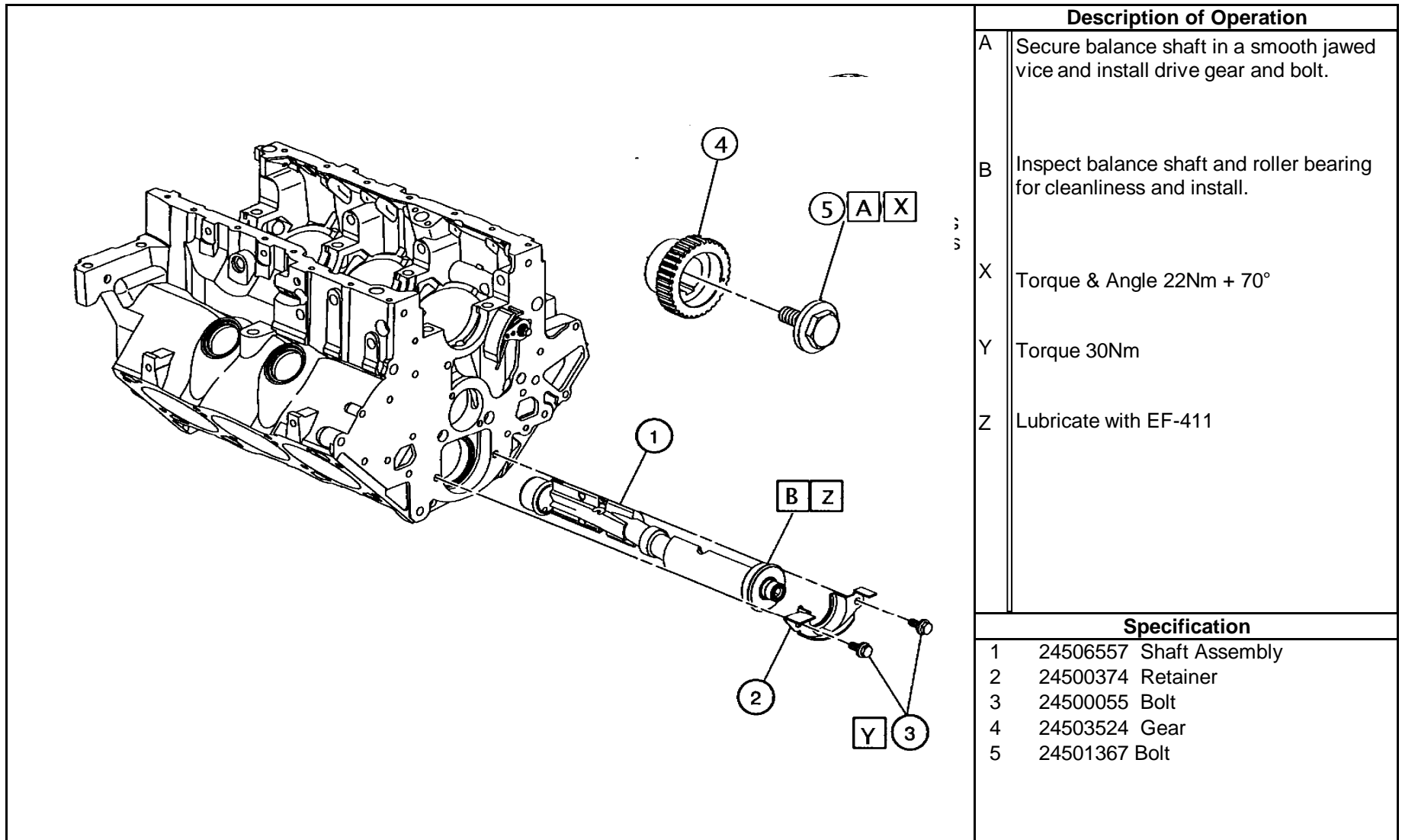

Description of Operation	
A	Secure balance shaft in a smooth jawed vice and install drive gear and bolt.
B	Inspect balance shaft and roller bearing for cleanliness and install.
X	Torque & Angle 22Nm + 70°
Y	Torque 30Nm
Z	Lubricate with EF-411

Specification	
1	24506557 Shaft Assembly
2	24500374 Retainer
3	24500055 Bolt
4	24503524 Gear
5	24501367 Bolt

REV	Date	Revision History
1	1/5/98	Block-19
2	6/22/06	Add 24506557 shaft assembly part number
3	7/1/11	Removed balance shaft # 24503588, renumbered as sheet 13

Short Block	
Balance shaft inspect & install	

Short Block Assembly	Sequence III G
-----------------------------	-----------------------

Section	Sheet
3	13

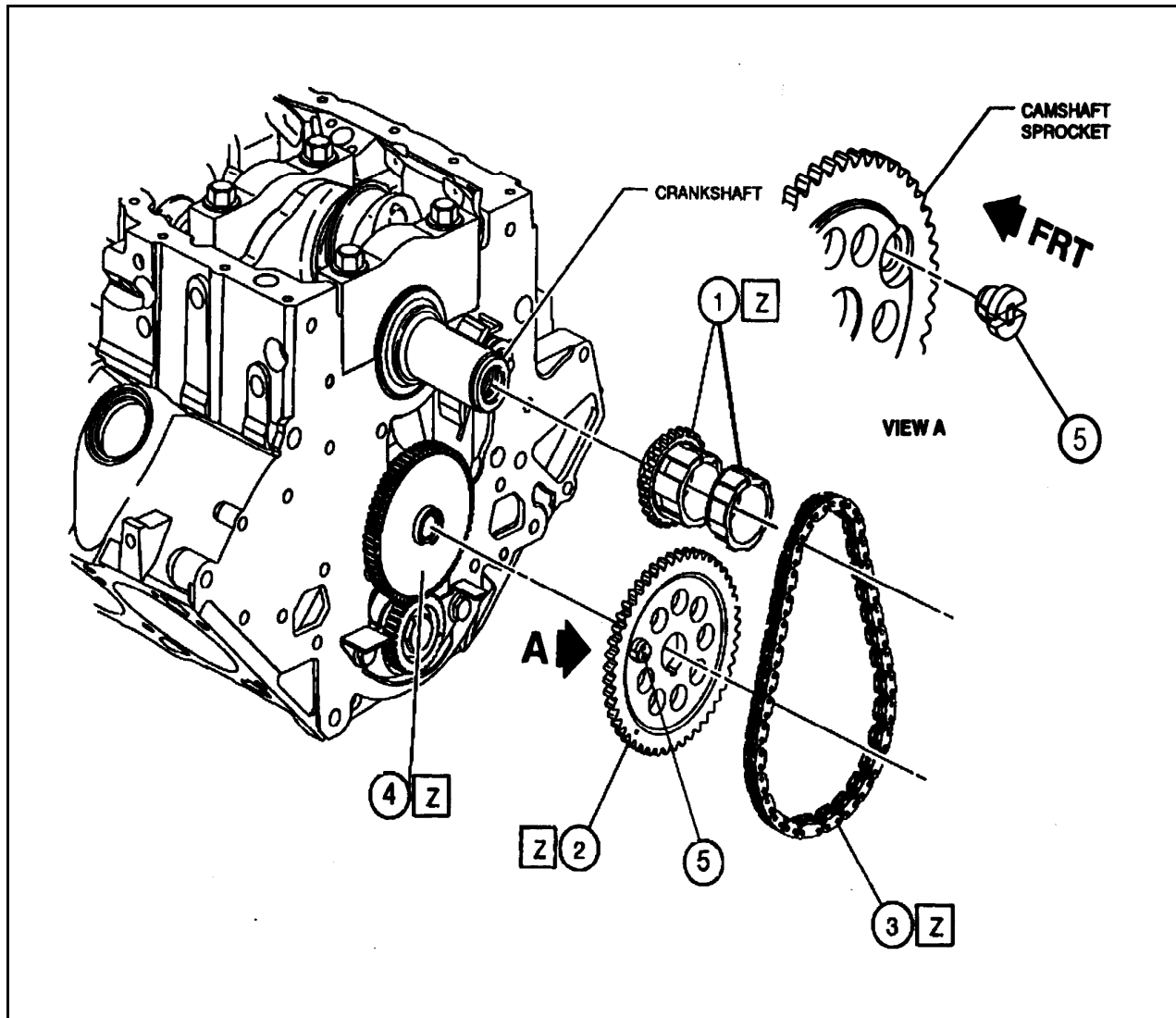

Description of Operation

Timing gear set. See part number information.

A Install magnet See view "A"

Z Lubricate with EF-411

Note: Inspect balance shaft and gears and replace as necessary if damage to gear teeth and / or thrust surface is evident.

Specification

1	OHT3F-036-1 Sprocket, 2pc.
2	24505306 Sprocket, camshaft
3	24504668 Chain
4	24504792 Gear
5	10456195 Magnet

REV	Date	Revision History
1	1/5/98	Block-20
2	7/1/11	Renumbered as sheet 14

View

Short Block

Timing gear set

Short Block Assembly	Sequence III G
-----------------------------	-----------------------

Section	Sheet
3	14

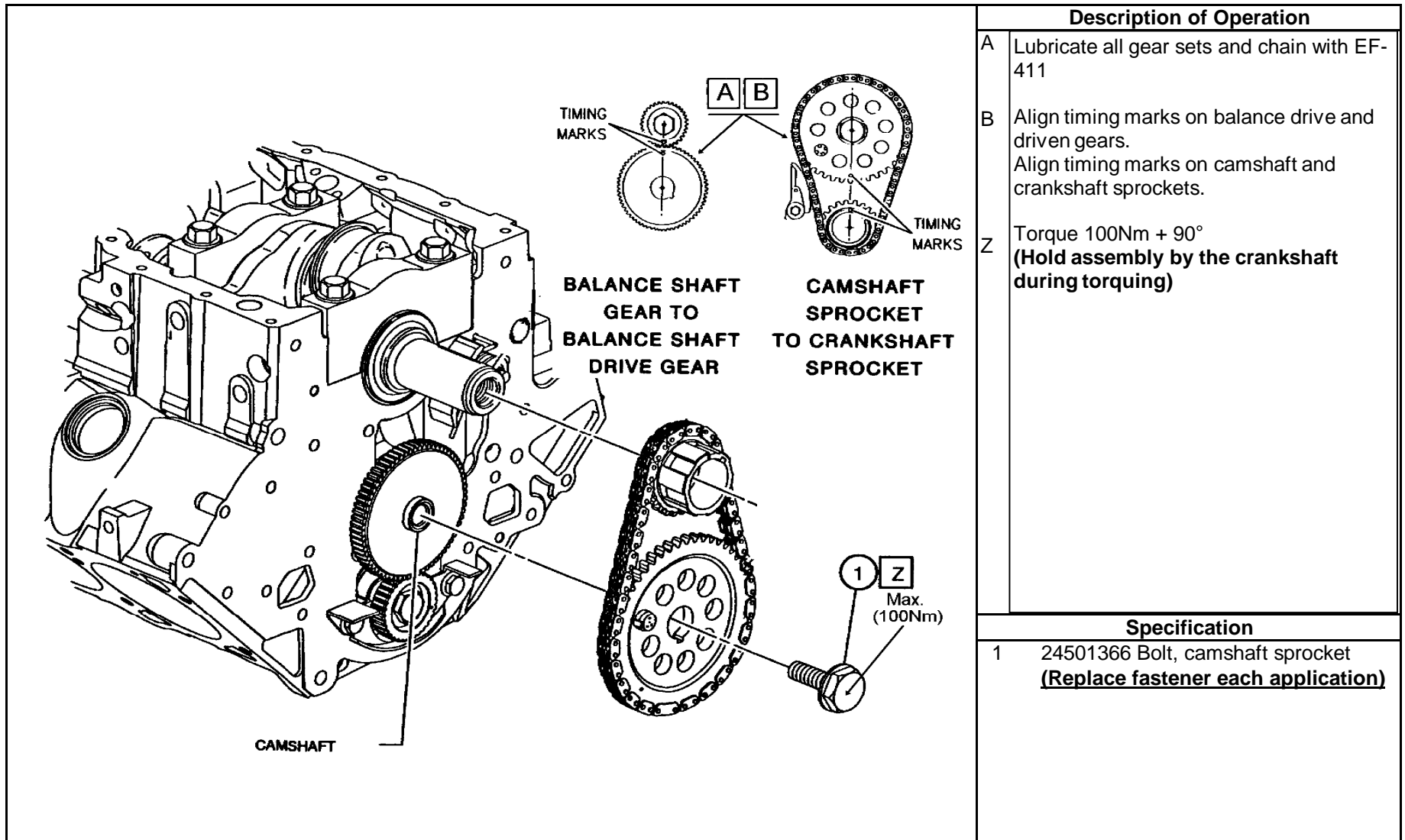

REV	Date	Revision History
1	1/5/98	Block-21
2	7/1/11	Renumbered as sheet 14
Short Block Assembly		Sequence III G

View	
Short Block	
Timing gear set alignment & torque	
Section	Sheet
3	15

Section 4

Front Cover, Rear Cover, and Sump

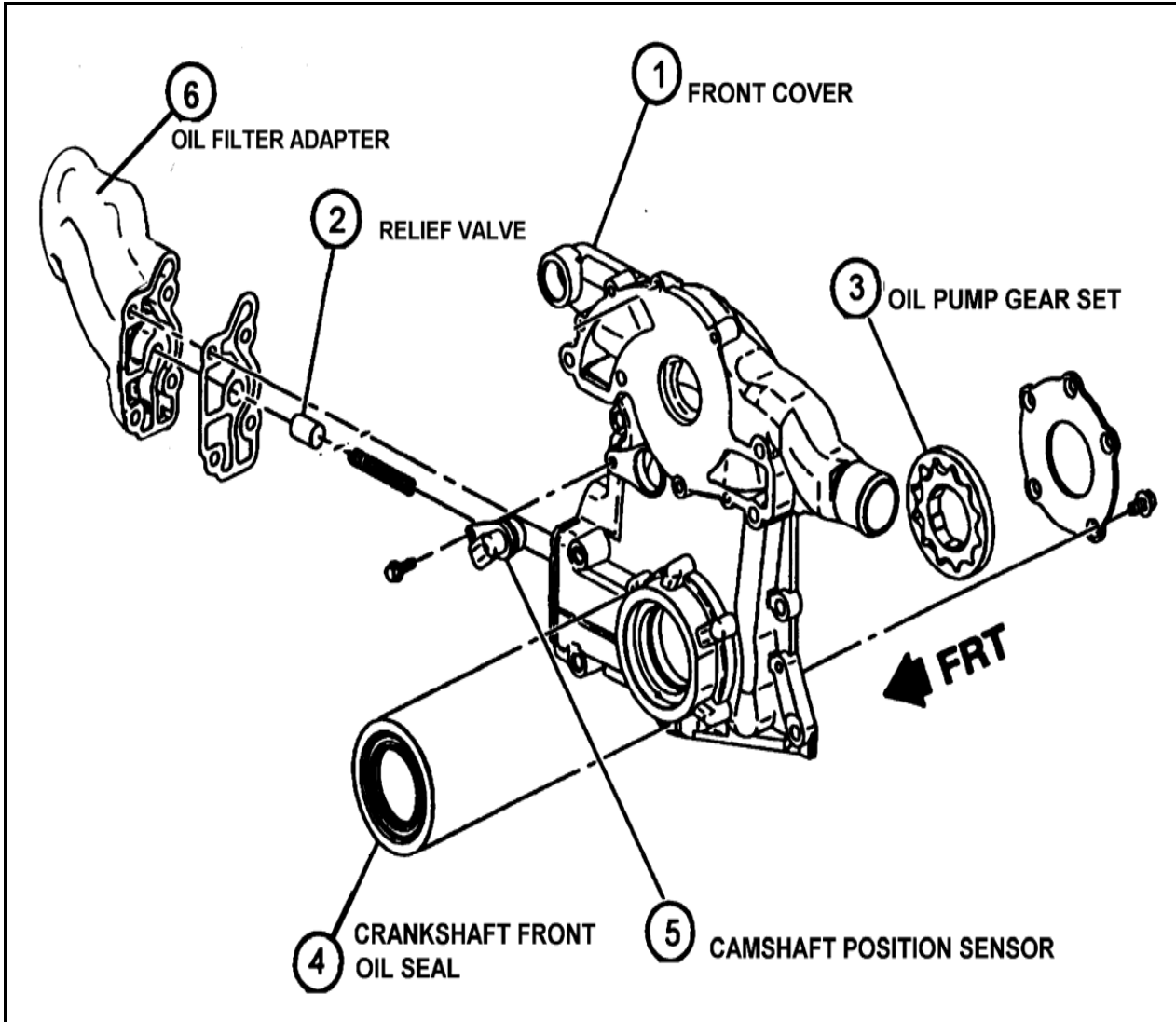

Description of Operation

Assembly view

Specification

1	OHT3F-085-1 Front Cover
2	25530949 Valve, oil pressure relief
3	24505433 Oil pump gear set
4	OHT3G-092-1 Seal
5	10456148 Camshaft position sensor
6	OHT3F-080-1 Adapter, oil filter

REV	Date	Revision History
1	01/05/98	Block-22
2	4/28/03	Change front cover over to OHT part number
3	11/03/04	Change front seal from 24504098 to OHT3G-092-1

View

Front Cover

Front cover assembly view

Front Cover, Rear Cover, & Sump **Sequence III G**

Section	Sheet
4	1

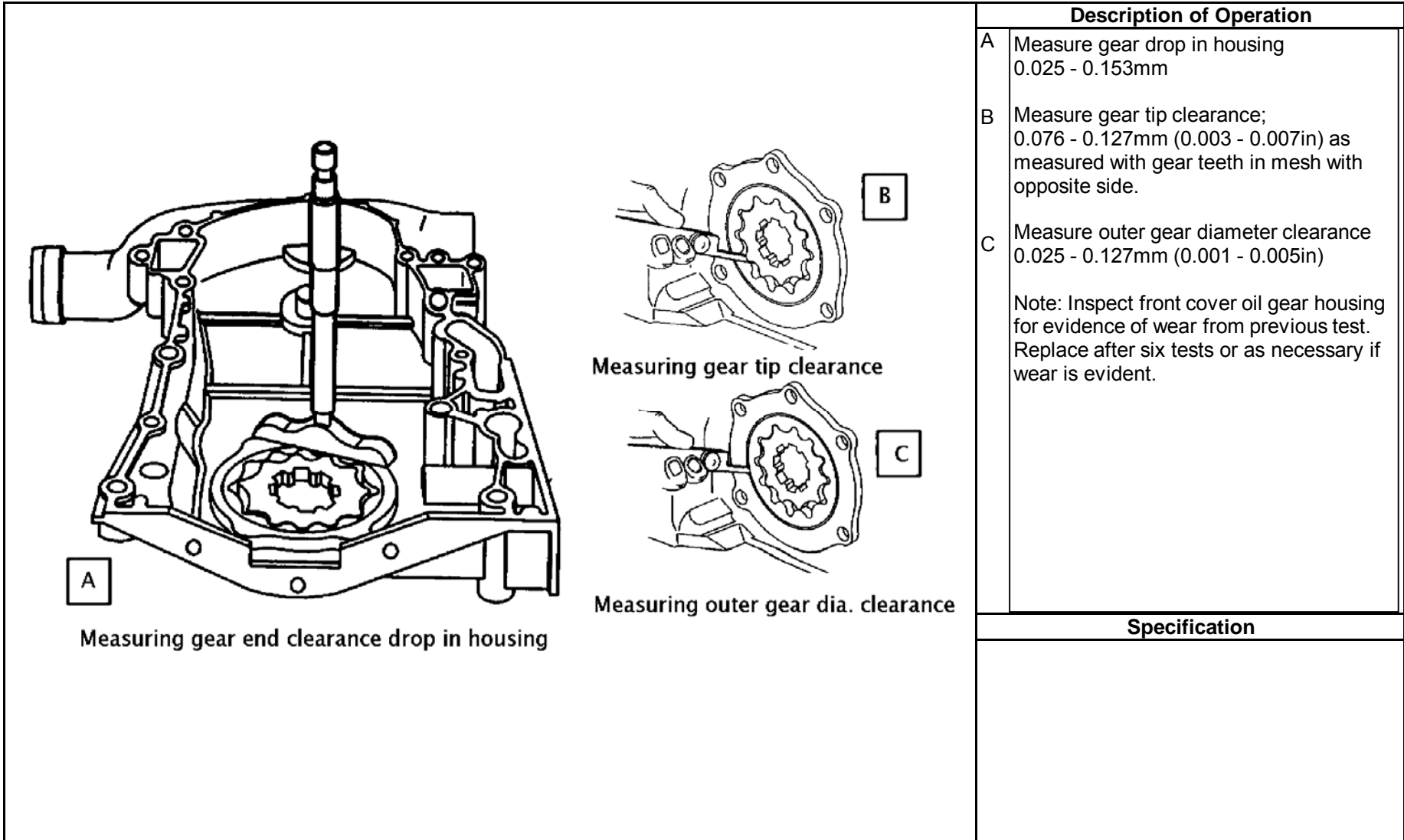

Description of Operation	
A	Measure gear drop in housing 0.025 - 0.153mm
B	Measure gear tip clearance; 0.076 - 0.127mm (0.003 - 0.007in) as measured with gear teeth in mesh with opposite side.
C	Measure outer gear diameter clearance 0.025 - 0.127mm (0.001 - 0.005in)
Note: Inspect front cover oil gear housing for evidence of wear from previous test. Replace after six tests or as necessary if wear is evident.	

Specification

REV	Date	Revision History
1	01/05/98	Block-23
2	06/22/06	Add usage information
3	05/02/13	Increased upper limit for drop in clearance to 0.153 mm

View
Front Cover
Oil pump gear clearance

Front Cover, Rear Cover, & Sump	Sequence III;	Section	Sheet
		4	2

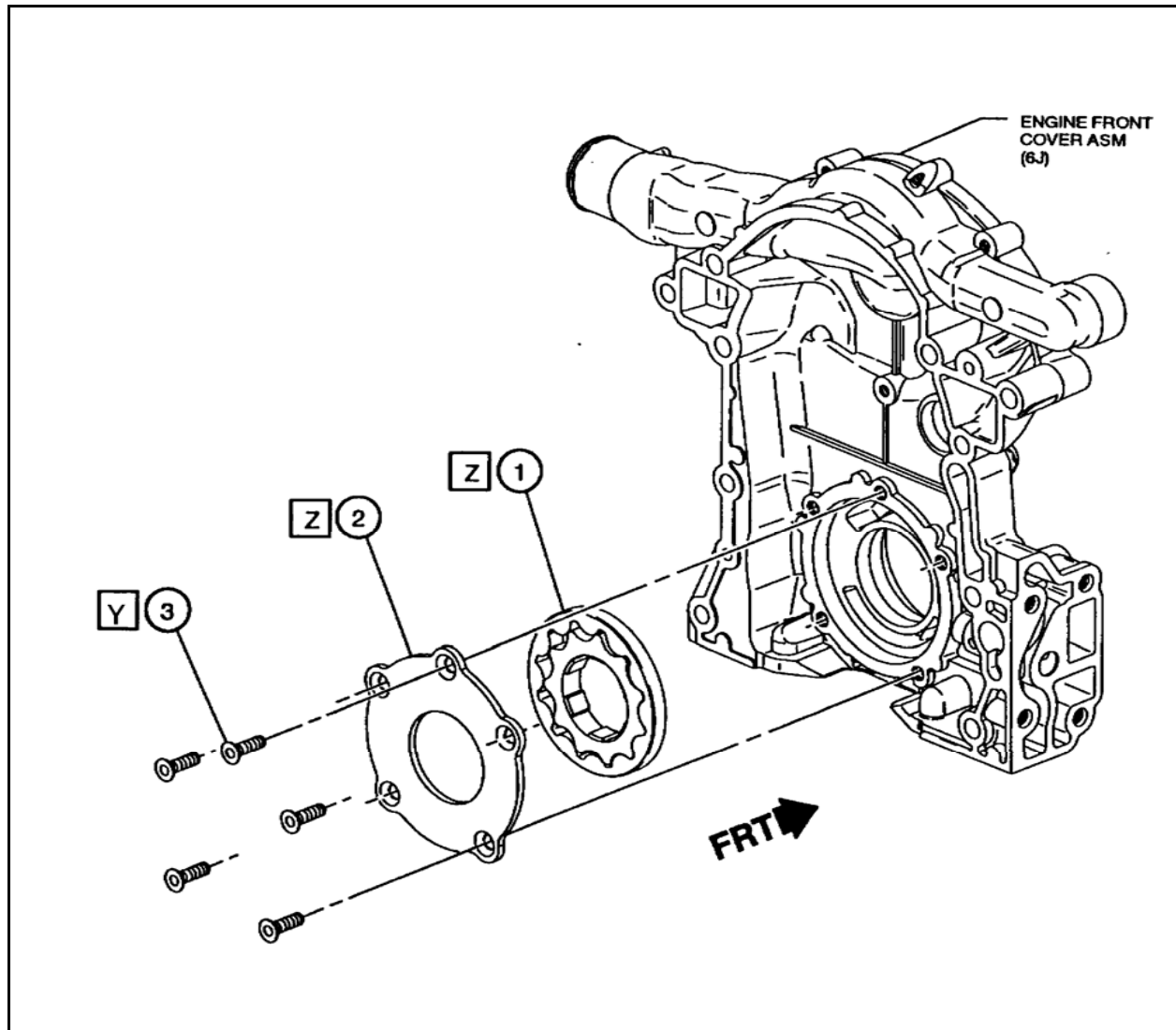

Description of Operation	
Y	Torque 11Nm
Z	Lubricate with EF-411

Specification	
1	24505433 Gear set
2	25521935 Cover, Gearotor
3	25519242 Bolt

REV	Date	Revision History
1	01/05/98	Block-24

View
Front Cover
Front cover oil gear install

Front Cover, Rear Cover, & Sump

Sequence III G

Section	Sheet
4	3

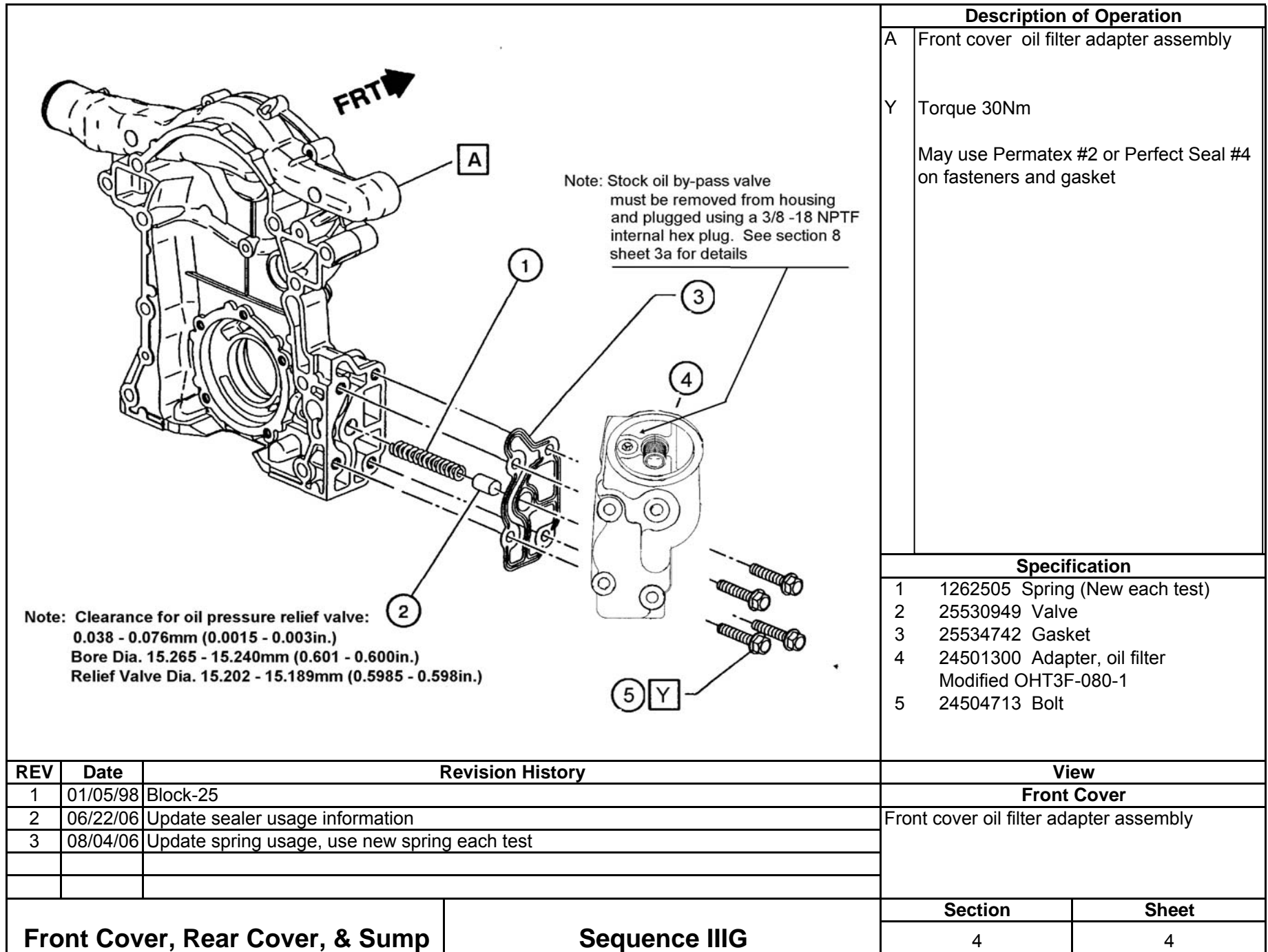

Description of Operation	
A	Front cover oil filter adapter assembly
Y	Torque 30Nm
	May use Permatex #2 or Perfect Seal #4 on fasteners and gasket

Specification	
1	1262505 Spring (New each test)
2	25530949 Valve
3	25534742 Gasket
4	24501300 Adapter, oil filter Modified OHT3F-080-1
5	24504713 Bolt

REV	Date	Revision History
1	01/05/98	Block-25
2	06/22/06	Update sealer usage information
3	08/04/06	Update spring usage, use new spring each test

View	
Front Cover	
Front cover oil filter adapter assembly	

Front Cover, Rear Cover, & Sump	Sequence III G
--	-----------------------

Section	Sheet
4	4

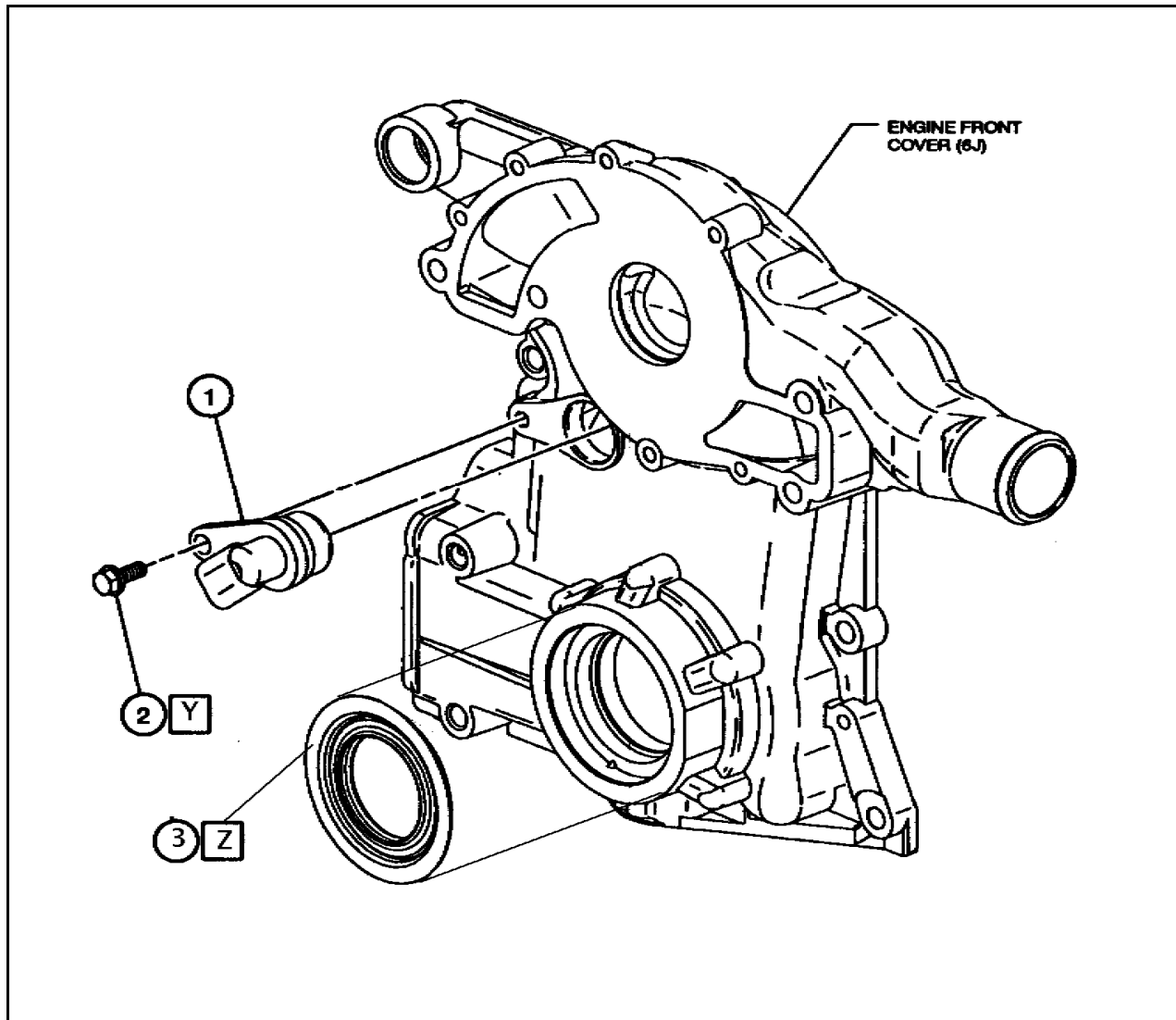

Description of Operation	
Y	Torque 30Nm
Z	Use a light application of #4 Permatex or RTV, Dow Corning®3145 RTV MIL-A-46146 Adhesive/Sealant or GM, (see part number info) around the rear side of the seal where it contacts the front cover. GM Silicone Sealer New numbers: 12378577 Tube 12551715 Cartridges

Specification	
1	10456148 Camshaft sensor
2	25526395 Bolt
3	OHT3G-092-1 Seal

REV	Date	Revision History
1	01/05/98	Block-29
2	12/15/03	Add approved silicone sealers
3	11/03/04	Change front seal part number to OHT3G-092-1
3	07/01/11	Updated Sealant information

View	
Front Cover	
Front cover camshaft sensor and seal install	

Front Cover, Rear Cover, & Sump	Sequence III G
--	-----------------------

Section	Sheet
4	5

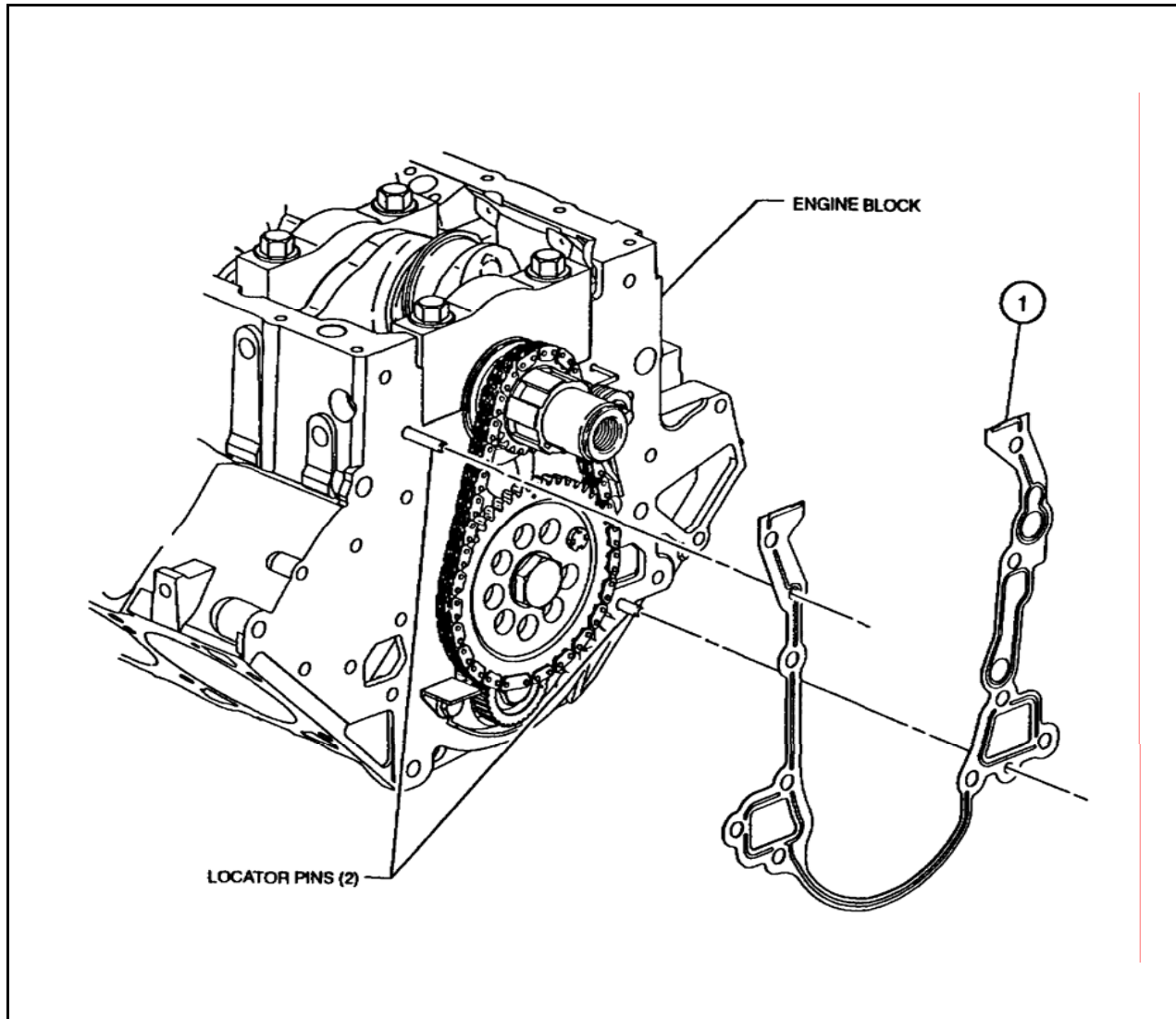

Description of Operation

Note:
Perfect seal #4 may be used around coolant passages on gasket.

Specification	
1	12587003 Gasket

REV	Date	Revision History
1	01/05/98	Block-26
2	03/03/07	Update new gasket 12587003 old number 24502252

View
Front Cover
Front cover gasket install

Front Cover, Rear Cover, & Sump	Sequence III G
--	-----------------------

Section	Sheet
4	6

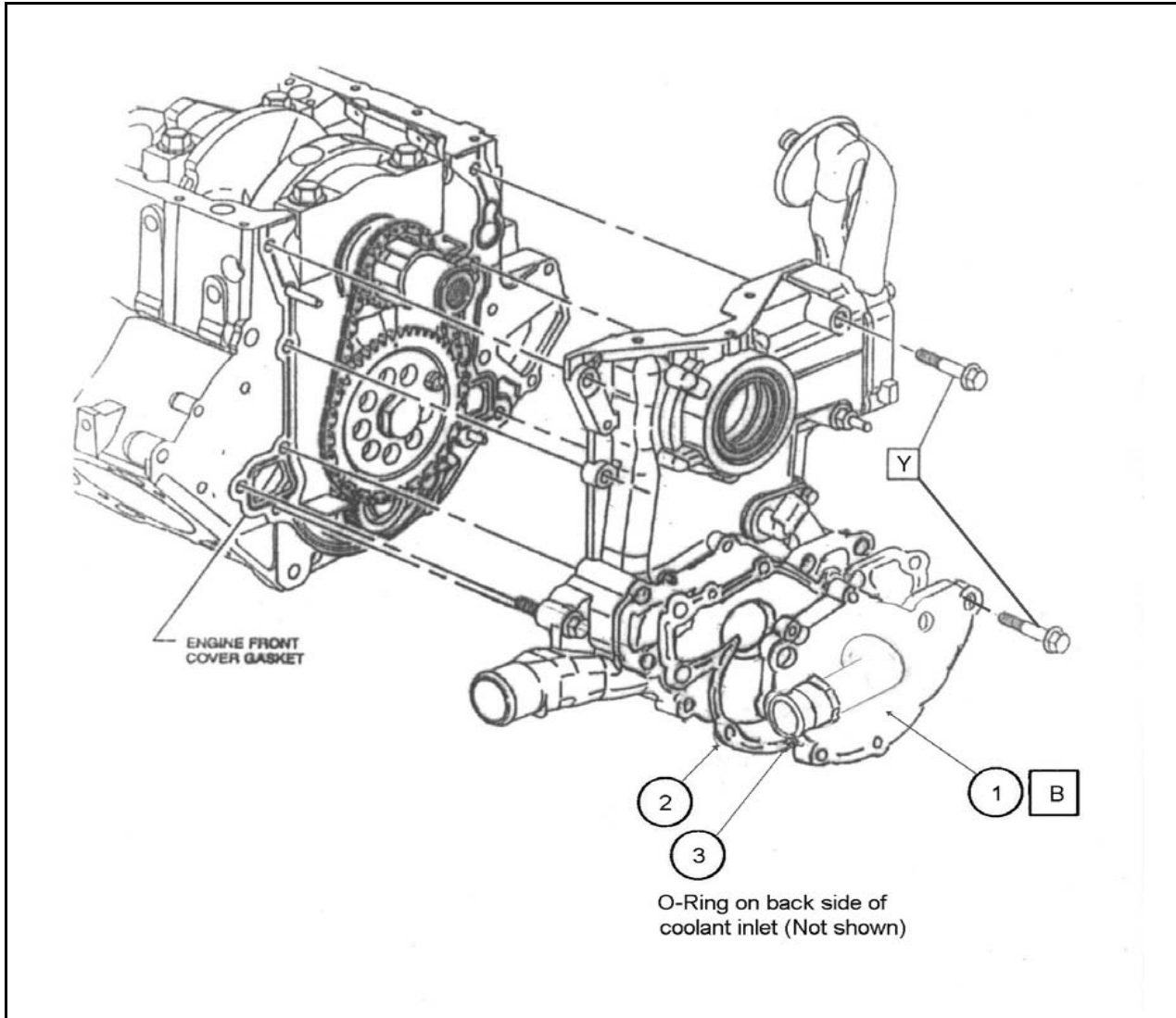

Description of Operation	
A	Front cover assembly
B	Install coolant inlet adapter with front cover
Y	Torque 30Nm Install thermocouple in OHT3F-031 with sensing tip centered in flow.

Specification	
1	OHT3F-031-3 Bolts included on print
2	24501565 Gasket
3	O-Ring 3F-031-2

REV	Date	Revision History
1	01/05/98	Block-30
2	12/01/99	Add thermocouple information
3	06/30/06	Update view, add gasket and O-ring part numbers

View	
Front Cover	
Front cover install	

Front Cover, Rear Cover, & Sump	Sequence III G
--	-----------------------

Section	Sheet
4	7

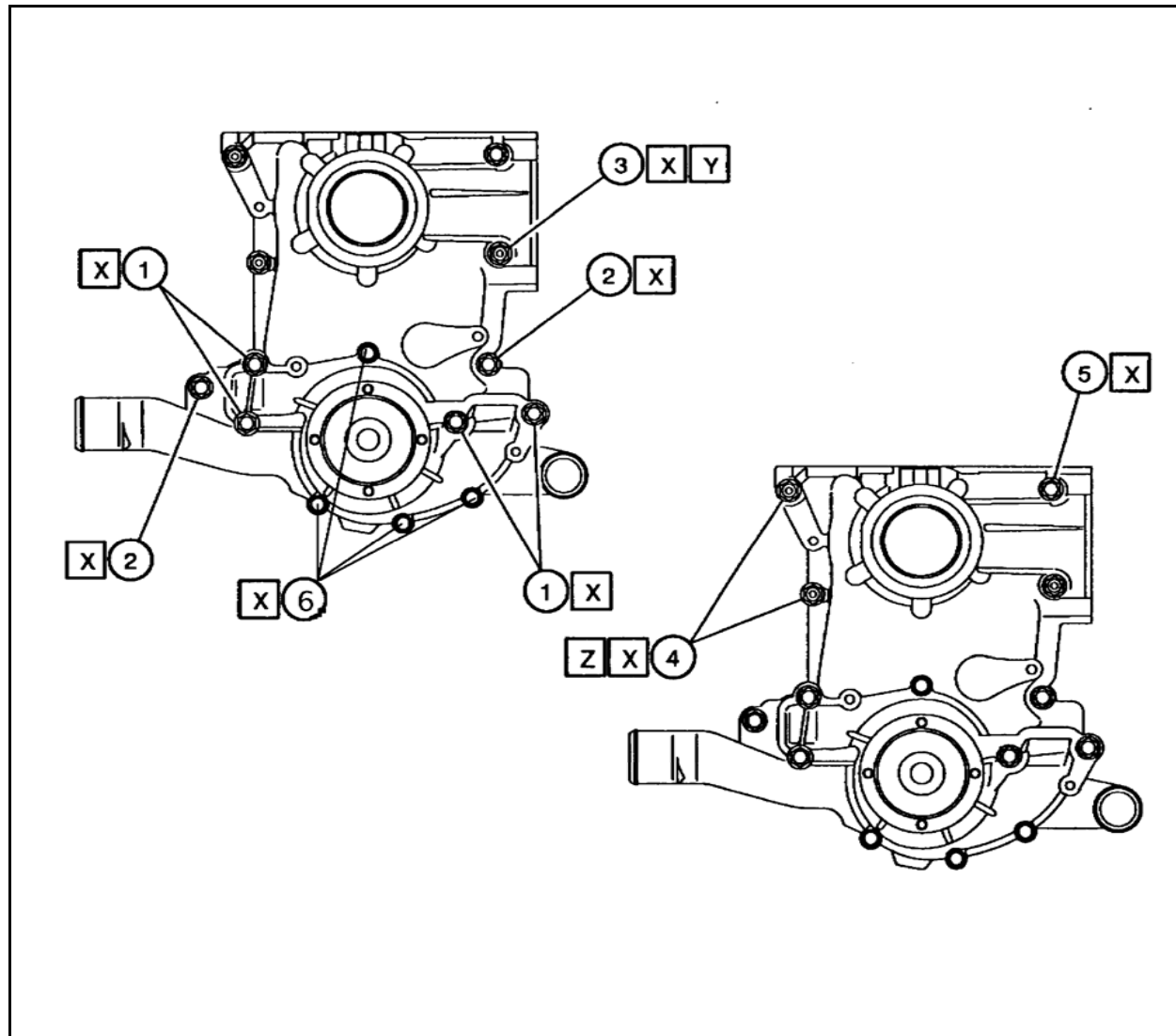

Description of Operation	
X	Torque 30Nm
Y	Stud also holds crankshaft sensor shield
Z	Studs also hold crankshaft sensor shield and sensor

Specification	
1	5/16-18x3.5 (3) plus 3F031-03 Stud (1)
2	24504713 Bolt (2)
3	24504718 Stud (2)
4	24504717 Stud (2)
5	24504712 Bolt
6	1/4-20x1.75

REV	Date	Revision History
1	01/05/98	Block-28
2	06/30/06	Update items 1 & 6 fastener information

View	
Front Cover	
Front cover bolt placement	

Front Cover, Rear Cover, & Sump	Sequence III G
--	-----------------------

Section	Sheet
4	8

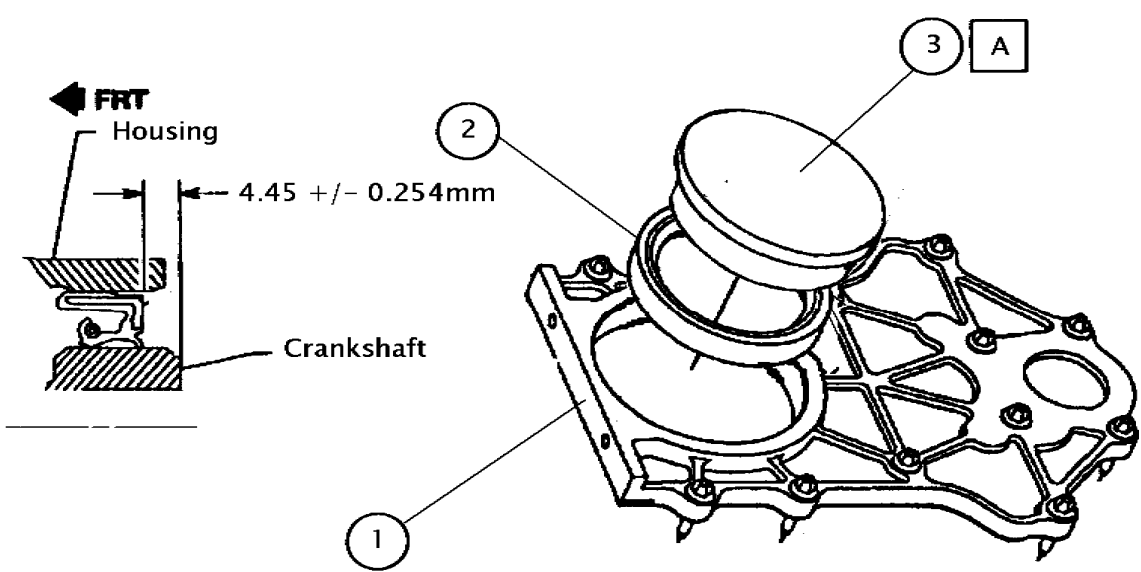

Description of Operation

A Install rear main lip seal using GM R&D supplied installation tool or Kentmore J38196 and a light duty bench press until seal bottoms in housing.

Specification

- 1 24502297 Rear cover housing
- 2 OHT3G-091-1 Seal
- 3 GM R&D Seal Installation Tool or Kentmore J38196

REV	Date	Revision History
1	01/05/98	Block-31
2	11/03/04	Change rear seal part number to OHT3G-091-1
2	02/22/10	Added Kentmore J38196 tool

View

Rear Cover

Rear seal installation

Front Cover, Rear Cover, & Sump	Sequence III G
--	-----------------------

Section

Sheet

4

9

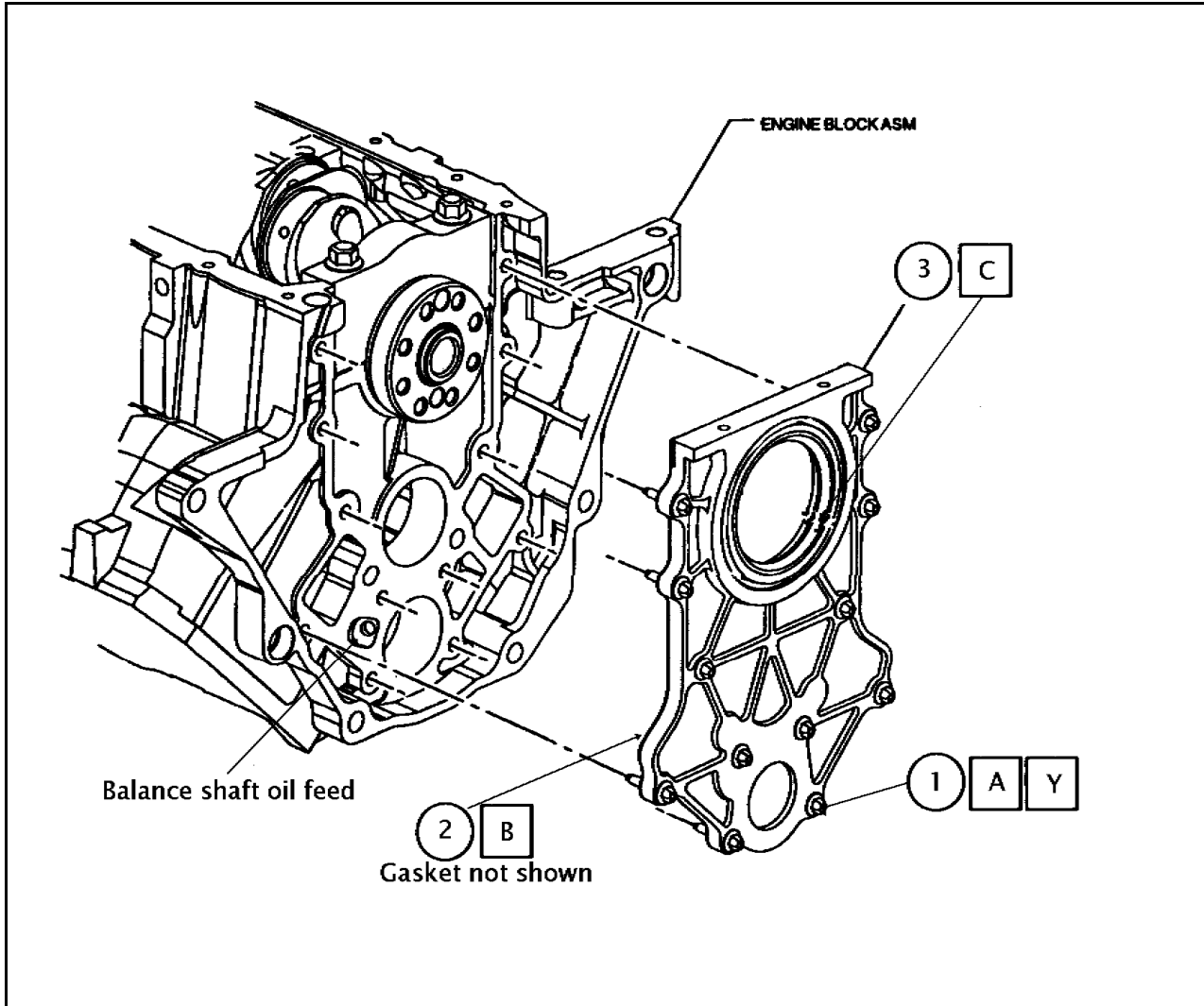

Description of Operation	
A	Bolts may be run for as long as they remain serviceable.
B	Install gasket (not shown in view) Note: Position rear cover plate gasket so that rear balance shaft oil feed is lined up with correct side of cover plate.
C	Lubricate rear lip seal with EF-411 and use extreme care not to damage rear lip seal during rear cover plate installation.
Y	Torque & Angle 15Nm + 50° Note: Perfect Seal #4 sealer may be used around coolant passages on gasket.

Specification	
1	11518075 Bolt
2	24507388 Gasket
3	OHT3G-088-1Rear cover housing

REV	Date	Revision History
1	01/05/98	Block-32
2	12/01/99	Add Perfect seal note.
3	02/05/06	Change to OHT Rear Cover w/24507388 gasket
4	07/20/06	Update fastener usage (remove nylon collar)
5	03/05/10	Update fastener usage (allowed use for multiple tests)
6	07/01/11	Revised part number for bolt, was 24503970, changed to 11518075

View	
Rear Cover	
Rear cover installation	

Front Cover, Rear Cover, & Sump	Sequence III G
--	-----------------------

Section	Sheet
4	10

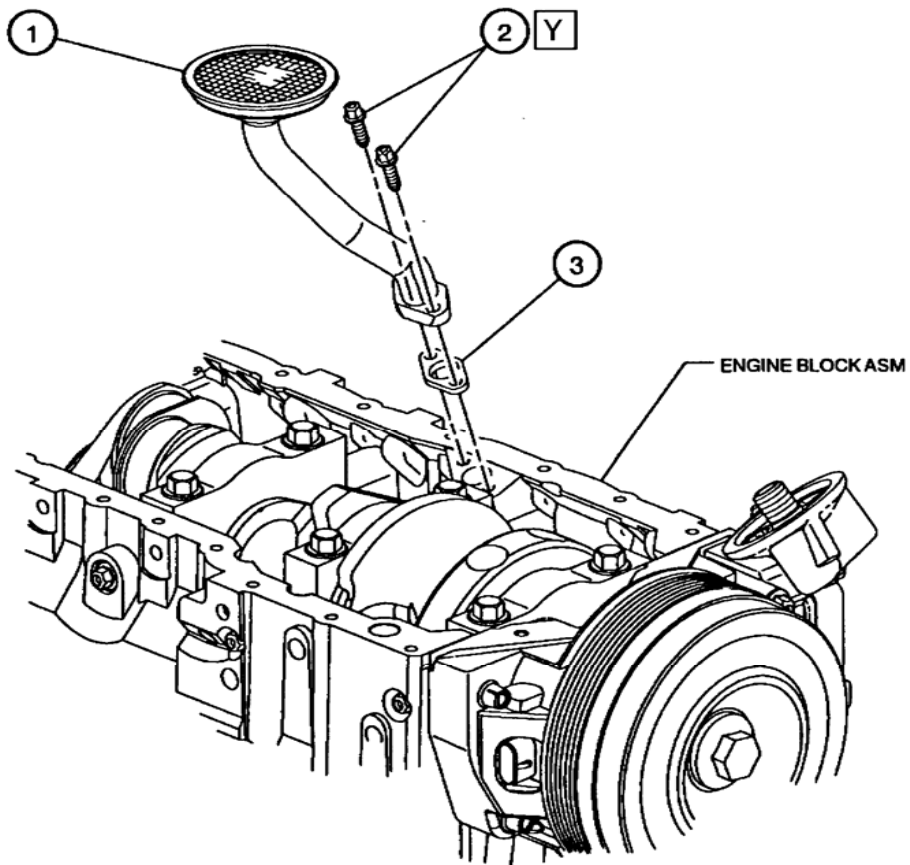

Description of Operation	
	Install oil screen assembly
Y	Torque 15Nm

Specification	
1	24505569 Screen assembly
2	24505570 Bolt
3	12581570 Gasket

View	
Sump	
Oil pickup tube	

Section	Sheet
4	11

REV	Date	Revision History
1	01/05/98	Block-33
2	02/01/06	Change gskt. From 24501259 to 12581570

Front Cover, Rear Cover, & Sump	Sequence III G
--	-----------------------

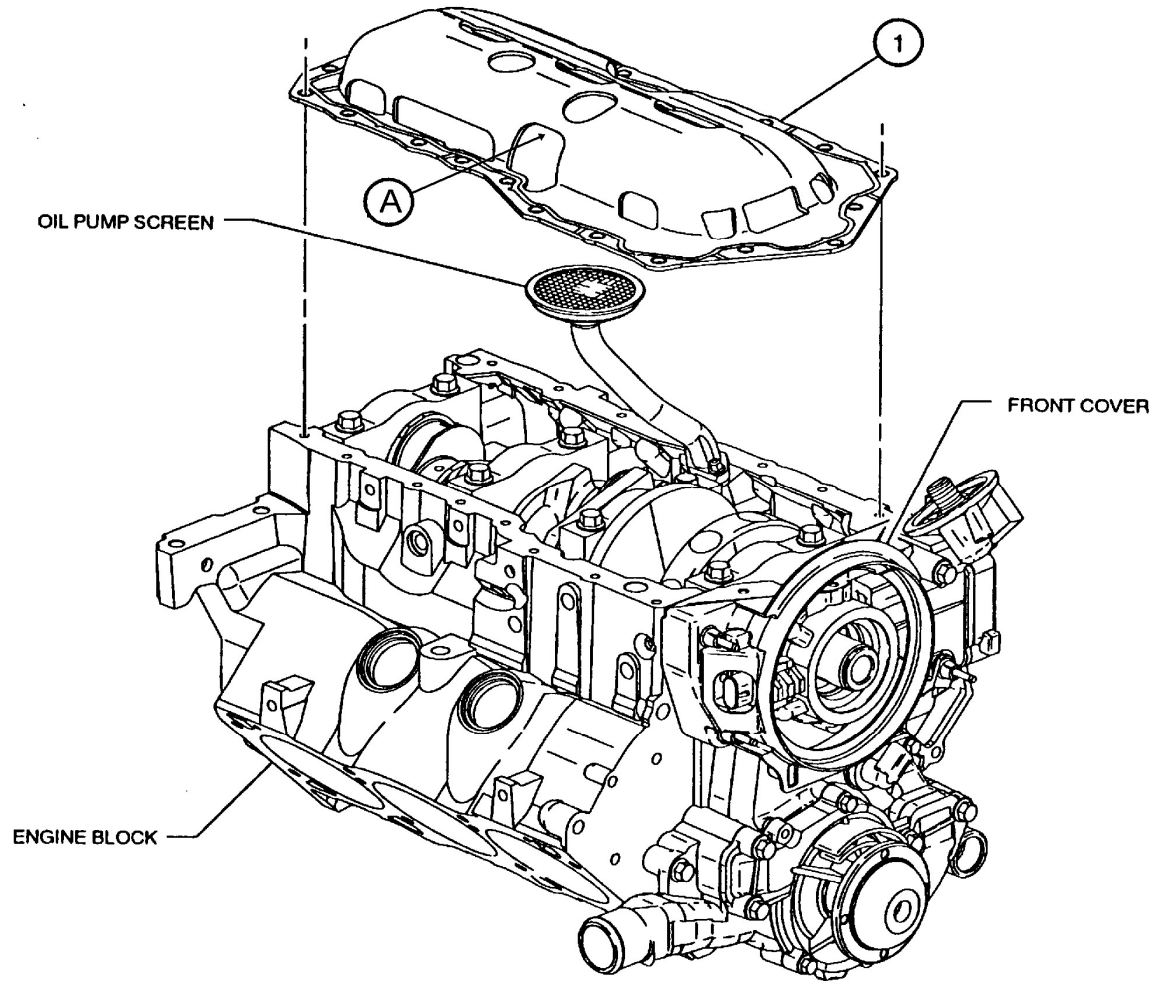

Install oil pan gasket

A Insure that calibrated oil level dipstick clears windage tray before final assembly

Note: Dow Corning®3145 RTV MIL-A-46146 Adhesive/Sealant or GM, (see part number info) or may be used at corners of front and rear covers to aid in sealing.

GM Silicone Sealer
 New numbers:
 12378577 Tube
 12551715 Cartridges

Specification

1 OHT3G-093-1 Gasket

**View
Sump**

Oil pan gasket install

Section	Sheet
4	12

REV	Date	Revision History
1	01/05/98	Block-34
2	4/28/03	Change part number from 24502397 to 12574776
3	12/15/03	Add approved silicone sealers
4	03/15/04	Update Sealer information
5	11/03/04	Change oil pan gasket to OHT3G-093-1
6	07/01/11	Update sealer information

Front Cover, Rear Cover, & Sump

Sequence III G

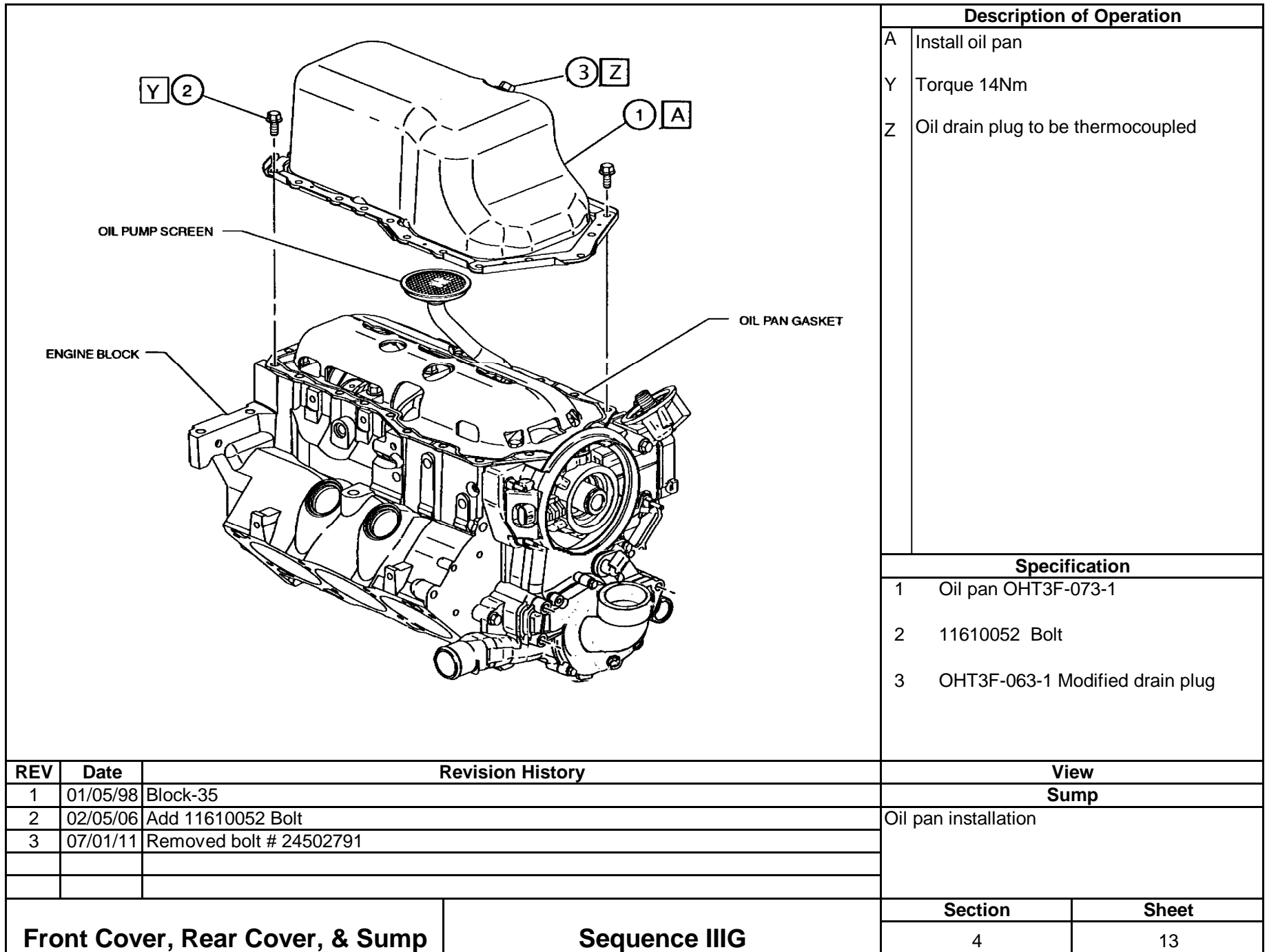

Description of Operation	
A	Install oil pan
Y	Torque 14Nm
Z	Oil drain plug to be thermocoupled

Specification	
1	Oil pan OHT3F-073-1
2	11610052 Bolt
3	OHT3F-063-1 Modified drain plug

REV	Date	Revision History
1	01/05/98	Block-35
2	02/05/06	Add 11610052 Bolt
3	07/01/11	Removed bolt # 24502791

View
Sump
Oil pan installation

Front Cover, Rear Cover, & Sump

Sequence III G

Section	Sheet
4	13

Section 5

Cylinder Head and Valves

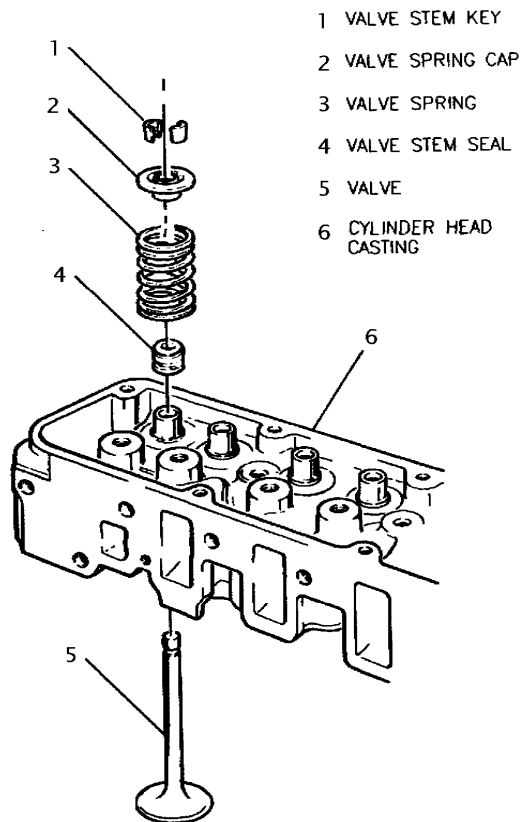

- 1 VALVE STEM KEY
- 2 VALVE SPRING CAP
- 3 VALVE SPRING
- 4 VALVE STEM SEAL
- 5 VALVE
- 6 CYLINDER HEAD CASTING

During calibration, use OHT3F-070-1 Sleeve to protect seals from being cut and OHT3F-072, 006", 010", 015", & 020" shims to assist in

Description of Operation

Clean cylinder head by automated parts washer (see section 1 sheet 5A) or with degreasing solvent and spray with 50/50 solution of EF-411 and degreasing solvent. Remove excess solution using compressed air.

Lubricate valve stems and guides with EF-411 during assembly. Ensure valve stem moves freely in guide before installing valve seal. Use a protective sheath over the valve stem that extends downward past the keeper grooves when installing the valve stem seals.

Install the valve springs, retainers, and keepers.

Calibrate the valve spring load to 912N +/- 44N @ 9.5mm (205lbf +/- 10lbf @ 0.375in.) travel.

Specification

- 1 10166345 Valve stem key
- 2 24502257 Valve spring cap
- 3 OHT3G-059-1 Valve spring (Pink)
- 4 OHT3F-060-1 Seal int.
OHT3F-061-1 Seal exh. White stripe
- 5 12569550 Valve Int. (STD)
12579949 Valve Exh.(STD)
- 6 24502260B Head, GM Raceshop

View

Head Assembly

Valve & spring assembly

REV	Date	Revision History
1	01/06/98	Block-36
2	9/9/03	Change calibration from +/- 5lbf to +/- 10lbf
3	12/15/03	Update, change to mineral spirits
4	11/03/04	Change part number for exhaust valve from 24507423 to 12579949
5	06/30/06	Change intake part number from 24502254 to 12569550 and cleaning procedure update
6	07/01/11	Update cylinder head part number

Head Assembly

Sequence III G

Section

Sheet

5

1

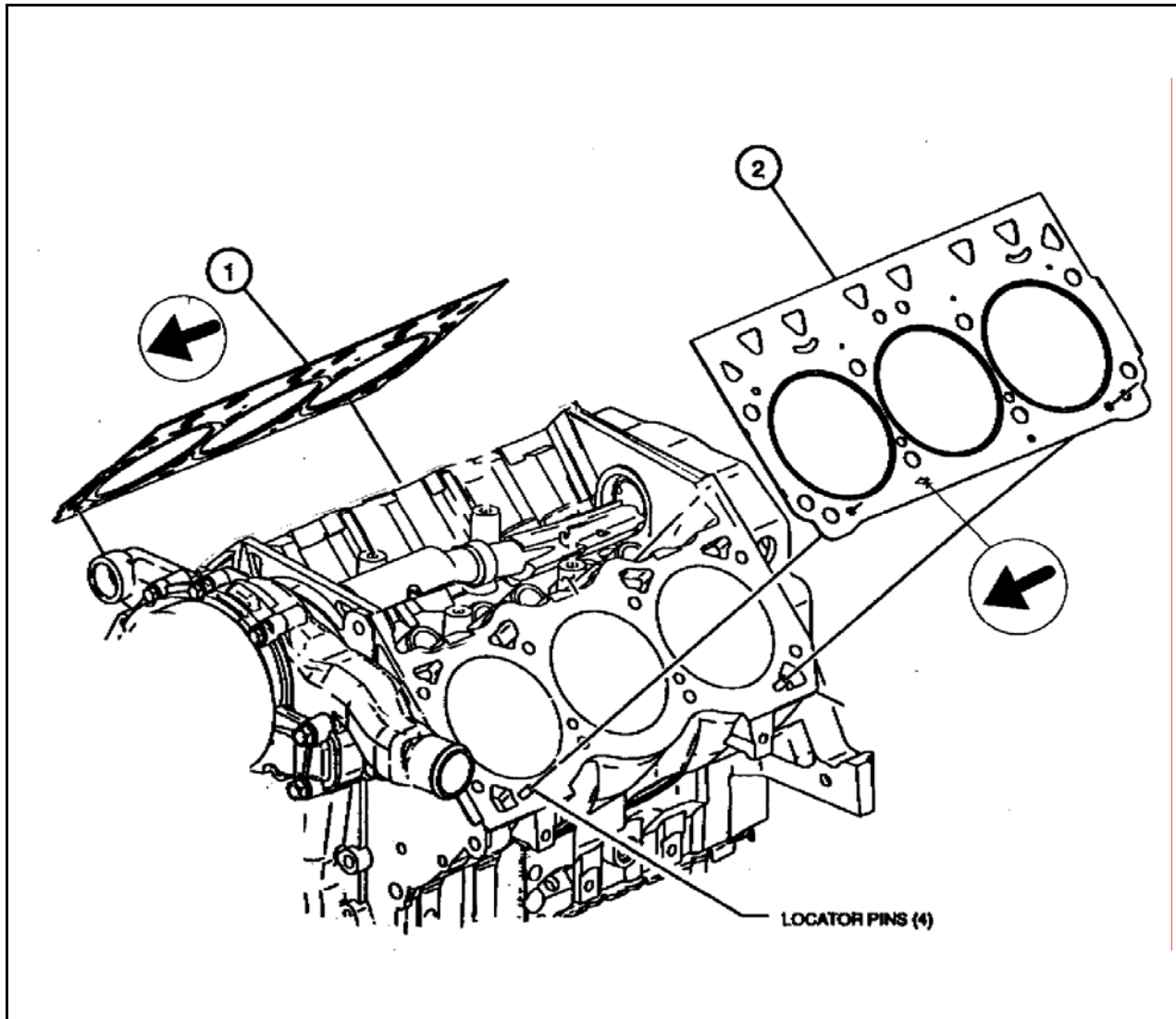

Description of Operation

Head gaskets are not interchangeable. Installing the head gasket with the arrow pointing to the rear will cause gasket failure and possible engine failure.

Install the head gasket with the arrow pointing toward the front of the engine.

Do not use any sealers on the head gaskets.

Specification		
1	24503801	Gasket RH
2	24503802	Gasket LH

REV	Date	Revision History
1	01/06/98	Block-37

View	
Head Gaskets	
Head gasket install	

Head Assembly	Sequence III G
----------------------	-----------------------

Section	Sheet
5	2

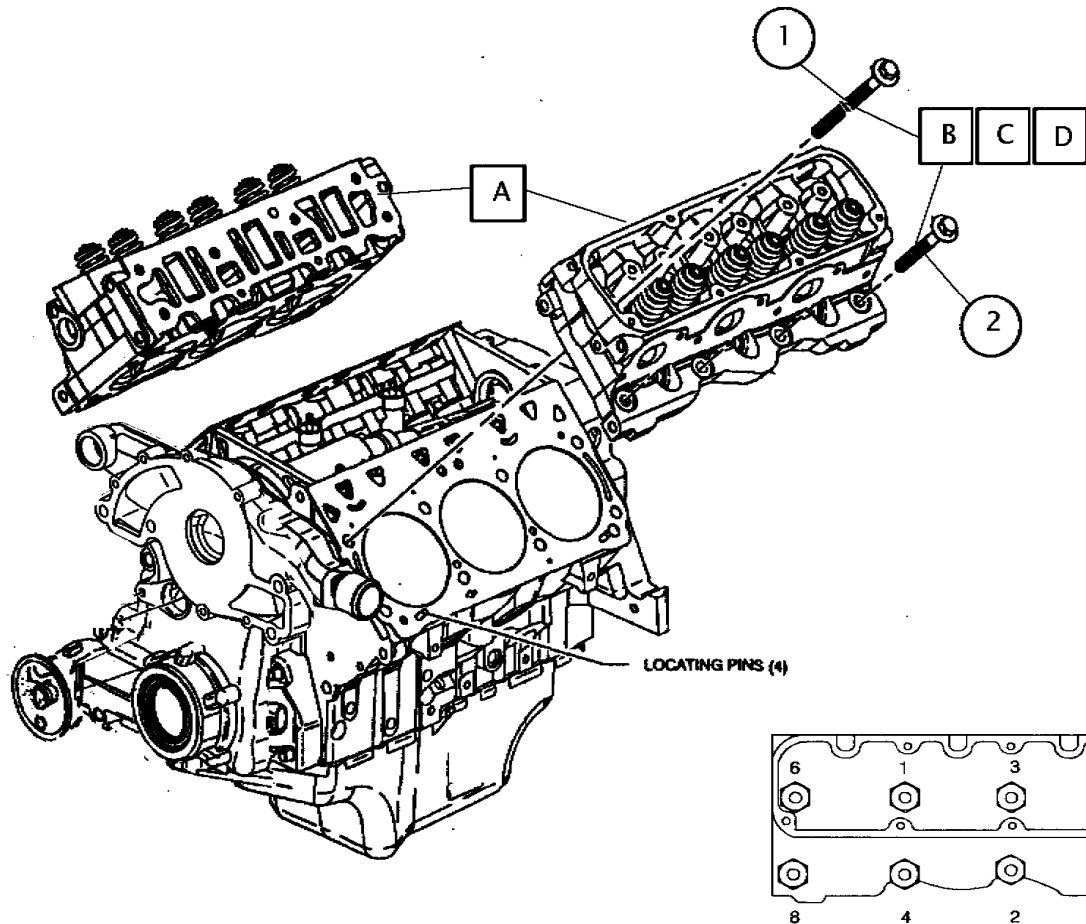

Description of Operation

- A Carefully install cylinder heads.
- B Clean all sealer from new bolt threads and underside of head.
- C Install #2 Permatex on threads and underside of fastener head.
- D Torque fasteners from center out using a crisscross pattern in the following sequence.
 First - 30 N·m
 Second - 50 N·m
 Third - 80 N·m
 Final - 145±7 N·m

Specification

- 1 25527831K Bolt Cyl. Head (8) Long
- 2 25533811K Bolt Cyl. Head (8) Short
Available through GM Race Shop

View

Cylinder Head

Cylinder head installation

Section

5

Sheet

3

REV	Date	Revision History
1	01/06/98	Block-38 & 50
2	07/20/06	Update part number, change 25533811 to 88891770
3	03/30/07	Update fastener torque to 30Nm-50Nm-80Nm-145Nm±7Nm
4	02/22/10	Corrected short head bolt number
5	07/01/11	Clarified torque sequence, updated head bolt info
Head Assembly		Sequence III G

Section 5a

Cylinder Head Part Number 24502260S and Valves

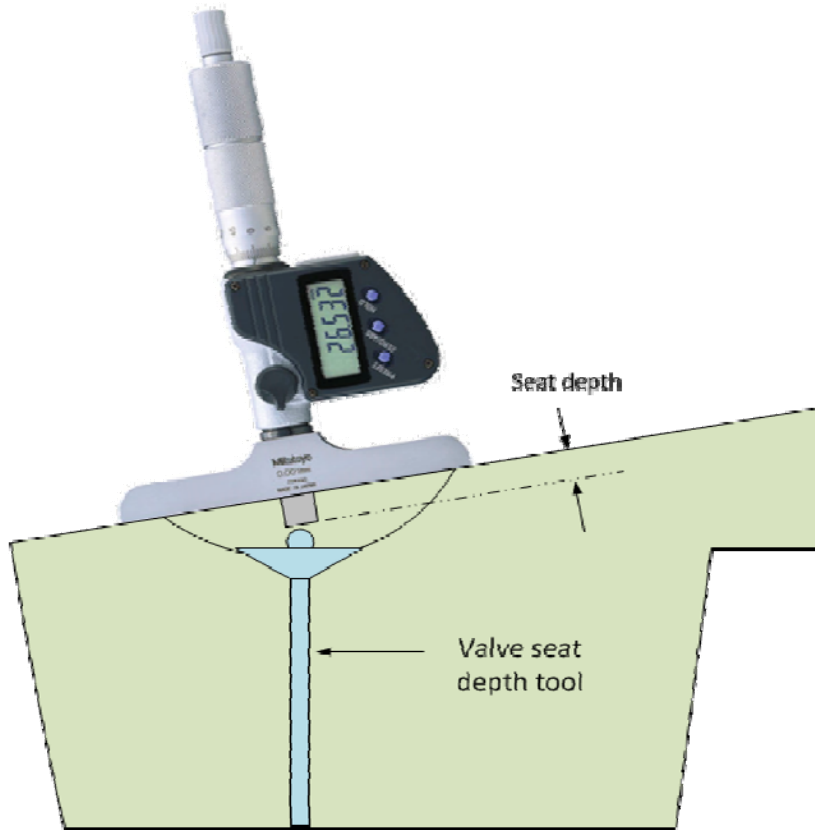

Description of Operation

Prior to use, determine baseline for valve recession by measuring the seat depth using a valve with a 0.321 diameter ball afixed to the center of the valve. Remove a minimum of 1/2 inch of the valve stem to preclude valve stem from pertruding beyond the top of the guide.

Measure the baseline valve set depth to the nearest thousandth (0.001) inch using a Mitutoyo model 329-711-10 or 329-350-10 depth micrometer.

Specification

1 24502260S Head, GM Raceshop

View

Head Assembly

Initial Measurements

Section

5a

Sheet

1

REV	Date	Revision History

Head Assembly

Sequence III G

			Description of Operation	
			<p>When reusing cylinder head part number 240502260S, Clean cylinder head by automated parts washer or ultrasound bath and spray with 50/50 solution of EF-411 and degreasing solvent. Remove excess solution using compressed air. Do not use sandpaper, scotchbrite pads or other abrasives to clean heads.</p> <p>Visually inspect seats for wear. Measure Valve recession using procedure in 5a, sheet 1. Reject any heads where valve recession exceeds 0.010"</p> <p>Measure valve guide clearances at top and bottom of guides. Reject any heads which do not meet clearance of 0.0015 to 0.0032 inch.</p>	
			Specification	
			View	
			Initial Prep, reusing Head 24052260S	
Head Assembly		Sequence IIIG		
		Section		Sheet
		5a		2

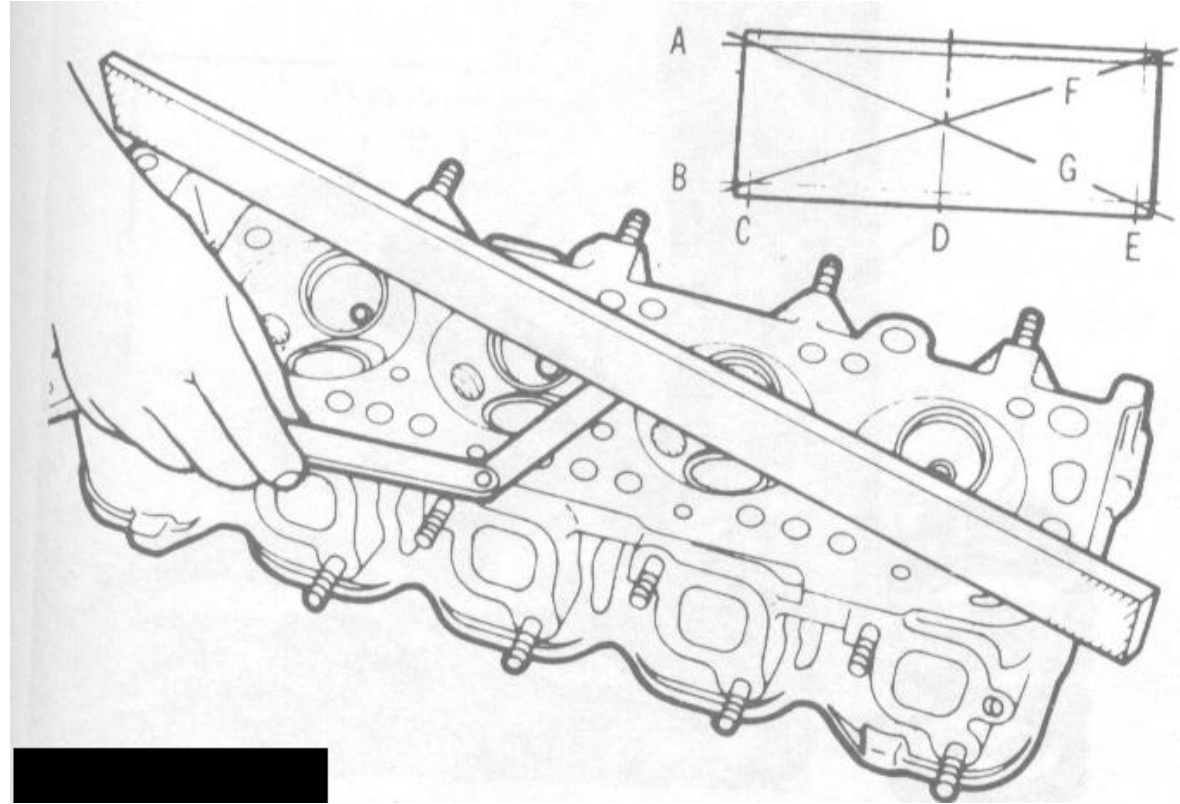

Description of Operation

Remove any remaining gasket material from the deck surface. Do not use sandpaper, scotchbrite or other abrasives which could transfer to the head surface.

Using a straight edge, measure the clearance between the straight edge and the head with a feeler gauge. Maximum .004"

Spray head with degreasing solvent and dry with compressed air. Wash heads in power washer for 30 minutes, or use ultra sonic cleaner for 30 minutes to remove debris from combustion chamber and intake and exhaust ports.

Rinse with hot water and immediately spray with 50-50 mixture of degreasing solvent and EF411

Specification

View

Initial Prep, reusing Head 24052260S

Section

5a

Sheet

3

REV	Date	Revision History

Head Assembly

Sequence III G

			Description of Operation			
			<p>Lap valves using a water based valve grinding compound. Use Permatex Valve Grinding Compound, water mixed, item #80036.</p> <p>Thoroughly clean lapping compound from valves and seats using water and a lint free rag. Be sure all lapping compound is removed. After cleaning lapping compound, spray entire head with degreasing solvent. Spray with, with 50-50 mixture of degreasing solvent and EF411 then blow dry with compressed air.</p> <p>Apply bluing to each valve and install. Visually inspect for proper seating. The bluing ring should be a consistent width around the entire valve circumference and be positioned toward the middle of the face. If valves show proper seating appearance, repeat "Pre Test Measurement Procedure". If Valve seat wear does not exceed 0.010" and meets factory valve seat width specifications (Intake Valve Seat Width = 0.060" – 0.080", Exhaust Valve Seat Width = 0.090" – 0.110"), heads are acceptable for re-use.</p>			
			Specification			
REV	Date	Revision History	View			
1	12/03/15	Added valve seat measurement re-use criteria	Head Preparations (continued)			
Head Assembly			Sequence III G		Section	Sheet
					5a	4

Description of Operation

Lubricate valve stems and guides with EF-411 during assembly. Ensure valve stem moves freely in guide before installing valve seal. Use a protective sheath over the valve stem that extends downward past the keeper grooves when installing valve stem seals.

Install the valve springs, retainers and keepers.

Calibrate the valve spring load to 912 N \pm 44N @ 9.5 mm (205lbf \pm 10lbf @ 0.375 in.) travel.

Apply a vacuum source to the heads and verify that a minimum of 24in. Hg can be obtained.

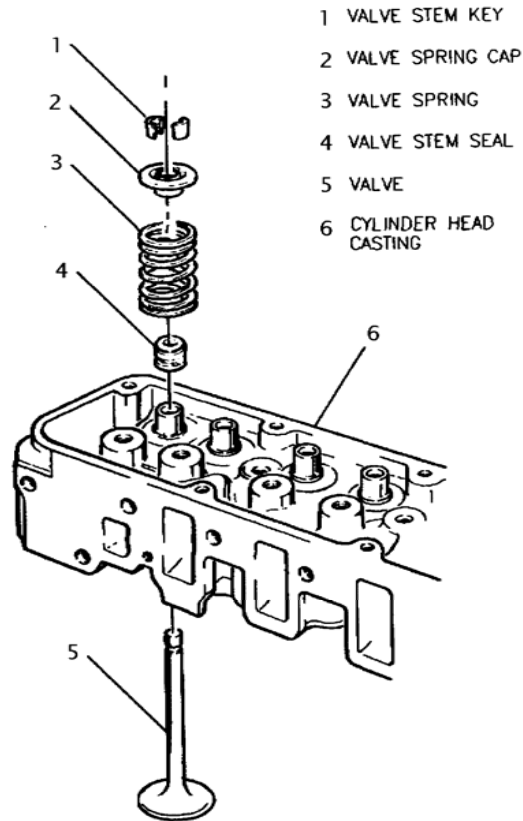

Specification

- 1 10166345 Valve stem key
- 2 24502257 Valve spring cap
- 3 OHT3G-059-1 Valve spring (Pink)
- 4 OHT3F-060-1 Seal intake
OHT3F-061-1 Seal exh (White stripe)
- 5 12569550 Valve, Intake (STD)
12579949 Valve, Exhaust (STD)
- 6 24502260S Head, GM Raceshop

REV	Date	Revision History

View

Valve and spring assembly

Head Assembly	Sequence IIIG
----------------------	----------------------

Section

5a

Sheet

5

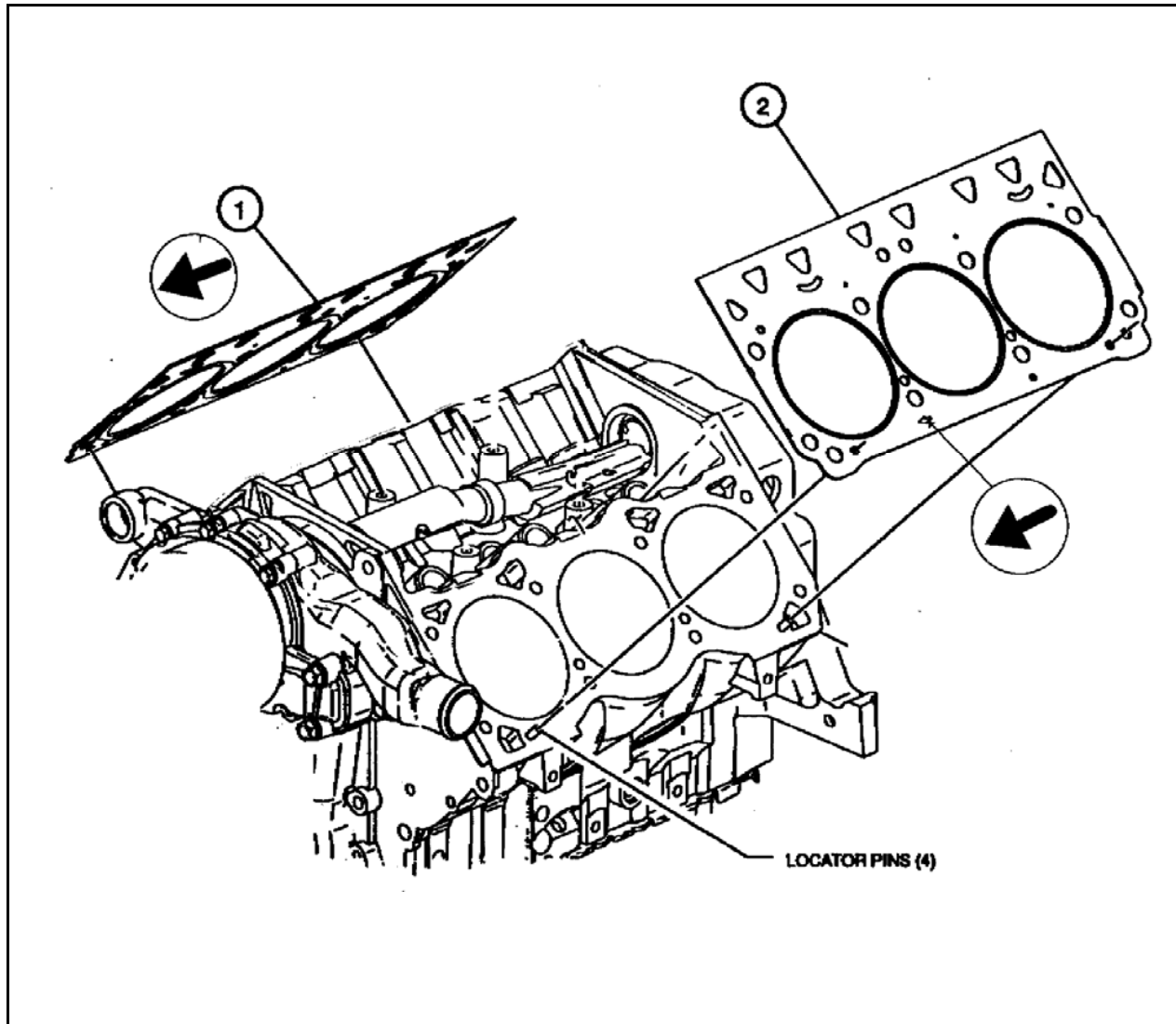

Description of Operation

Head gaskets are not interchangeable.

Installing the head gasket with the arrow pointing to the rear will cause gasket failure and possible engine failure.

Install the head gasket with the arrow pointing towards the front of the engine.

Do not use any sealers on the head gaskets.

Specification

- 1 24503801 Gasket RH
- 2 24503802 Gasket LH

REV	Date	Revision History
Head Assembly		Sequence III G

View	
Section	Sheet
5a	6

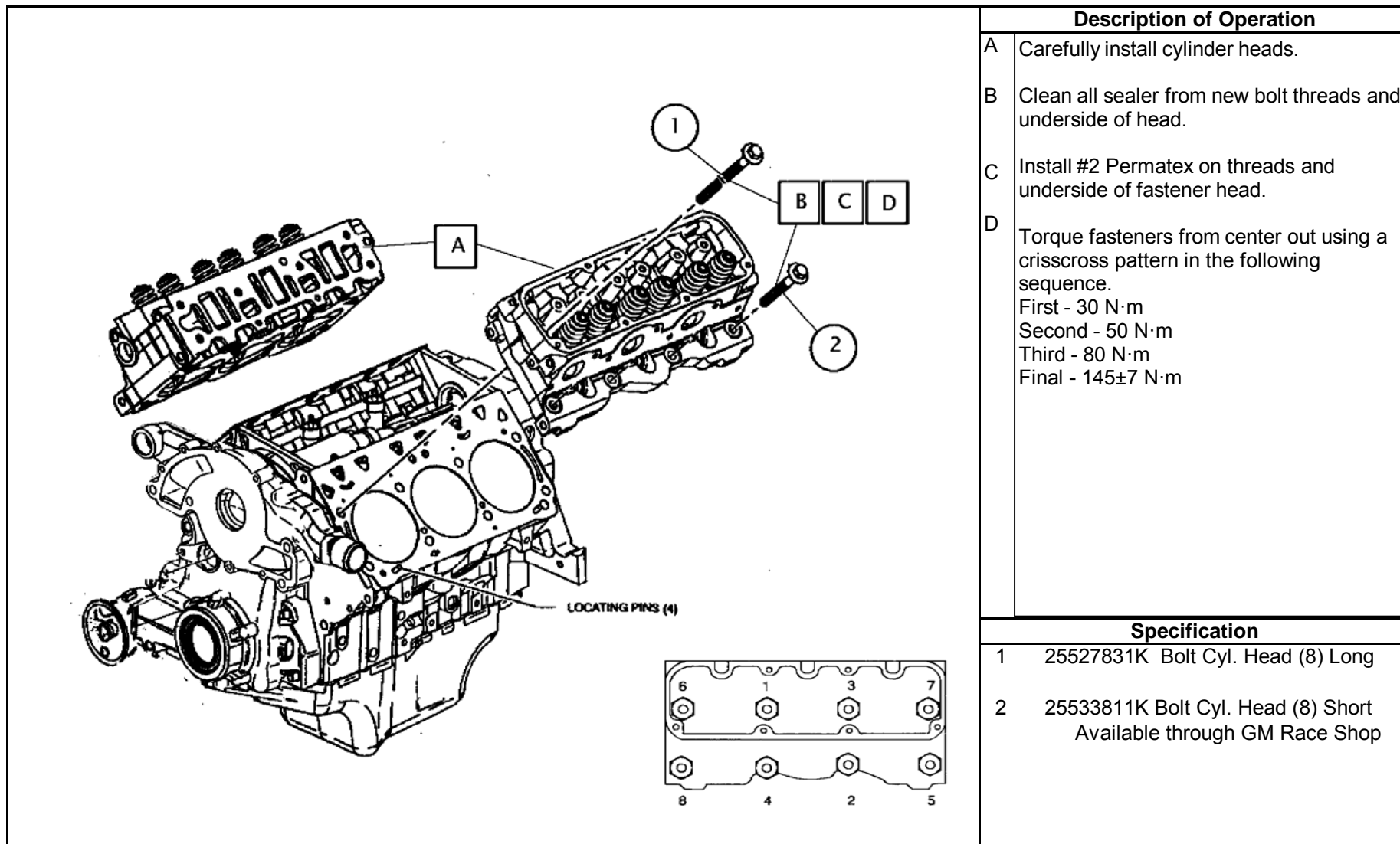

REV	Date	Revision History
1	01/06/98	Block-38 & 50
2	07/20/06	Update part number, change 25533811 to 88891770
3	03/30/07	Update fastener torque to 30Nm-50Nm-80Nm-145Nm±7Nm
4	02/22/10	Corrected short head bolt number
5	07/01/11	Clarified torque sequence, updated head bolt info
Head Assembly		Sequence III G

Description of Operation	
A	Carefully install cylinder heads.
B	Clean all sealer from new bolt threads and underside of head.
C	Install #2 Permatex on threads and underside of fastener head.
D	Torque fasteners from center out using a crisscross pattern in the following sequence. First - 30 N·m Second - 50 N·m Third - 80 N·m Final - 145±7 N·m

Specification	
1	25527831K Bolt Cyl. Head (8) Long
2	25533811K Bolt Cyl. Head (8) Short Available through GM Race Shop

View	
Cylinder Head	
Cylinder head installation	
Section	Sheet
5a	7

Section 6

Long Block Assembly

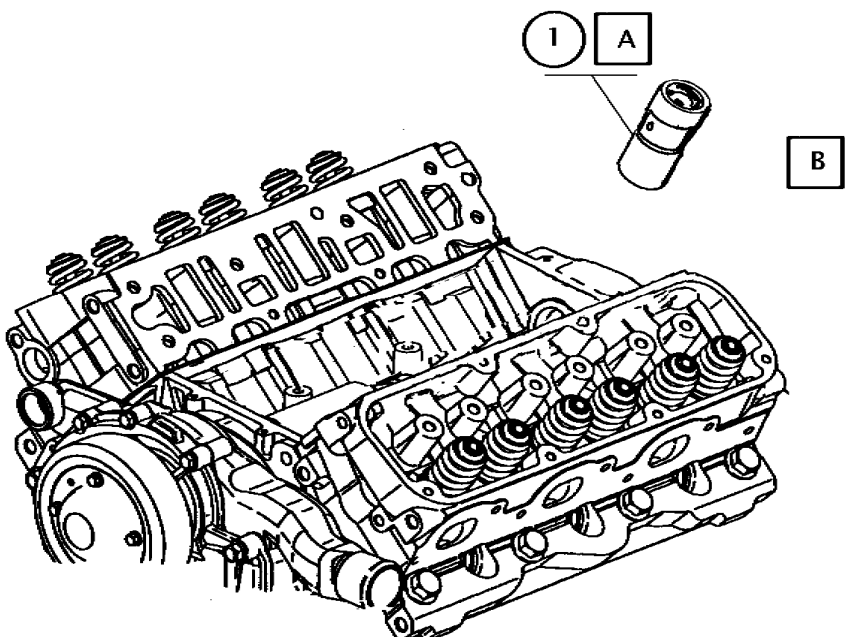
		Description of Operation	
		A	Measure and record pre-test lifter foot height to the nearest 0.001mm
		B	<p>Installation:</p> <p>1) Clean each lifter using a lightly soaked cloth with clean (new) degreasing solvent (Do not disassemble, spray, or submerge the lifter in solvent). Dry each lifter foot using a clean dry cloth or terry towel.</p> <p>2) Use 118ml (4 oz.) of test oil, dip each lifter foot in test oil and install the lifter set less pushrods.</p> <p>3) Rotate engine crankshaft 720° slowly with no load on lifters.</p> <p>4) Remove each lifter, one at a time, and again dip each foot in test oil and re-install with the ground flat facing inboard.</p> <p>5) With the oil pan on the engine, pour the remainder of the 118ml in the valley.</p>
		Specification	
		1	OHT3f-029-3 ACI Test Lifter (with flats)

REV	Date	Revision History
1	1/6/1998	Block-39
2	12/15/03	Update, change to mineral spirits
3	7/20/06	Update operation and change to degreasing solvent
4	7/1/11	Corrected typo in description B 2.

View	
Lifter Installation	
Lifter pre-oiling and installation	

Long Block Assembly

Sequence III G

Section	Sheet
6	1

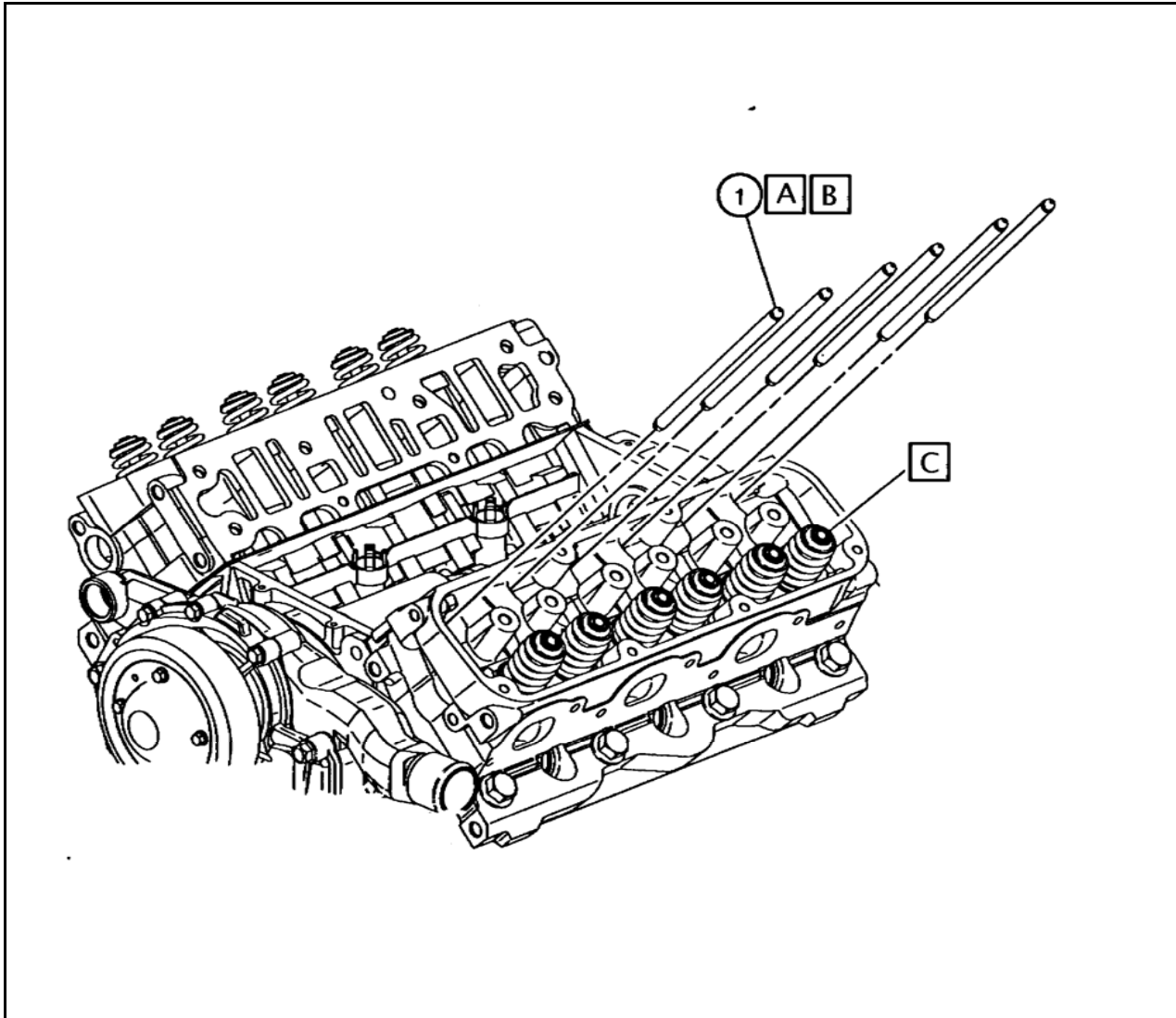

Description of Operation	
A	Clean all pushrods with clean lint free towel and degreasing solvent and spray with a 50/50 solution of EF-411 and degreasing solvent. Remove excess with compressed air. Lubricate each pushrod end, pushrod seat, and rocker arm ball socket with EF-411 prior to installation.
B	Install pushrods
C	Lubricate each valve stem seal and tip with EF-411.

Specification	
1	OHT3F-007-1 Pushrod (Special Length)

REV	Date	Revision History
1	1/6/1998	Block-40
2	12/15/03	Update, change to mineral spirits
3	7/20/06	Update change to degreasing solvent and clean towel for cleaning

View	
Pushrods	
Pushrod installation	

Long Block Assembly

Sequence III G

Section	Sheet
6	2

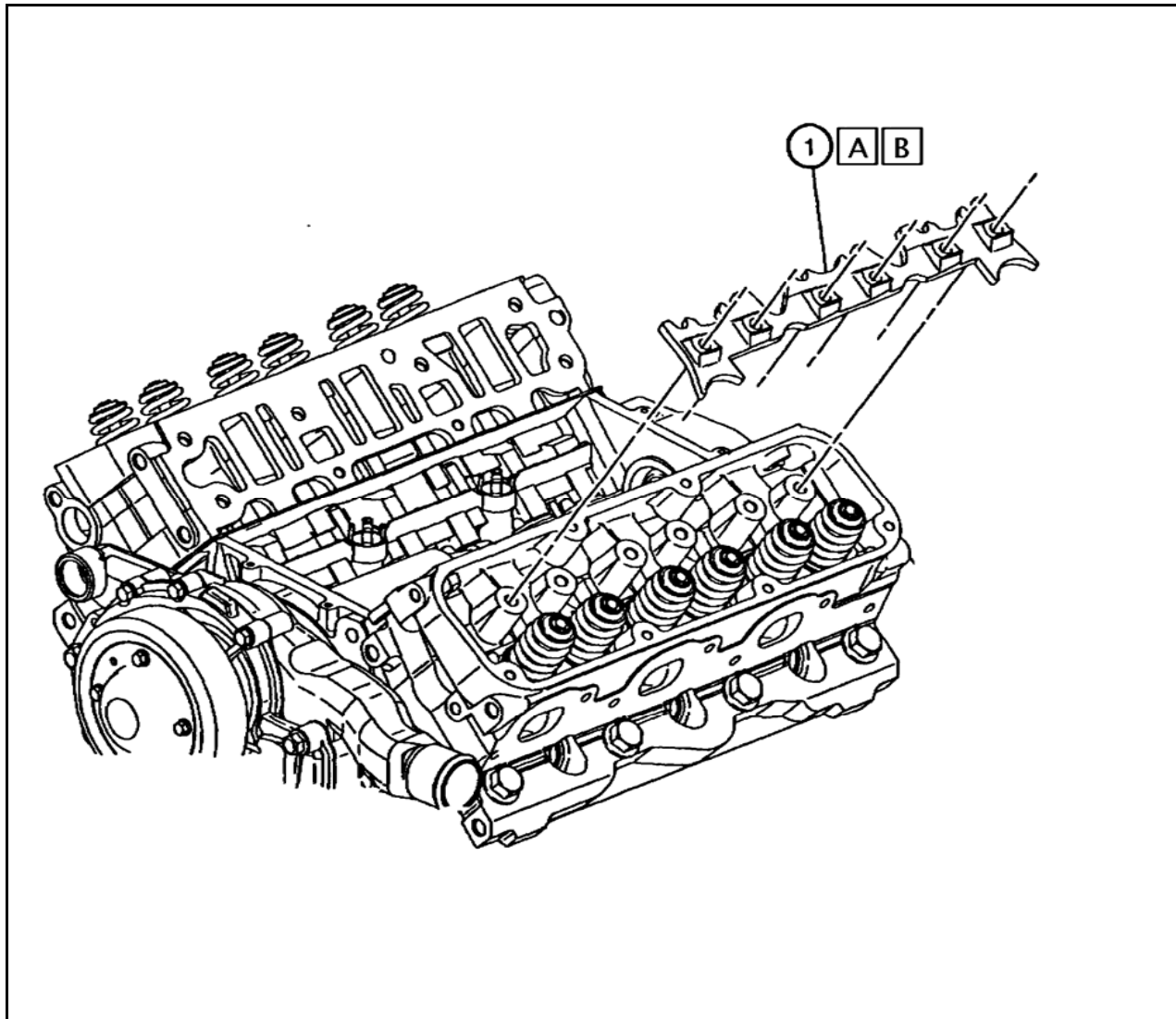

Description of Operation	
A	Clean and inspect for wear. (Replace Retainer after 6 tests)
B	Install pushrod guide / rocker bearing retainer.

Specification	
1	24502278 Retainer

REV	Date	Revision History
1	1/6/1998	Block-41
2	7/20/06	Update usage, replace after 6 tests

View
Retainer
Rocker bearing retainer installation

Long Block Assembly	Sequence III G
----------------------------	-----------------------

Section	Sheet
6	3

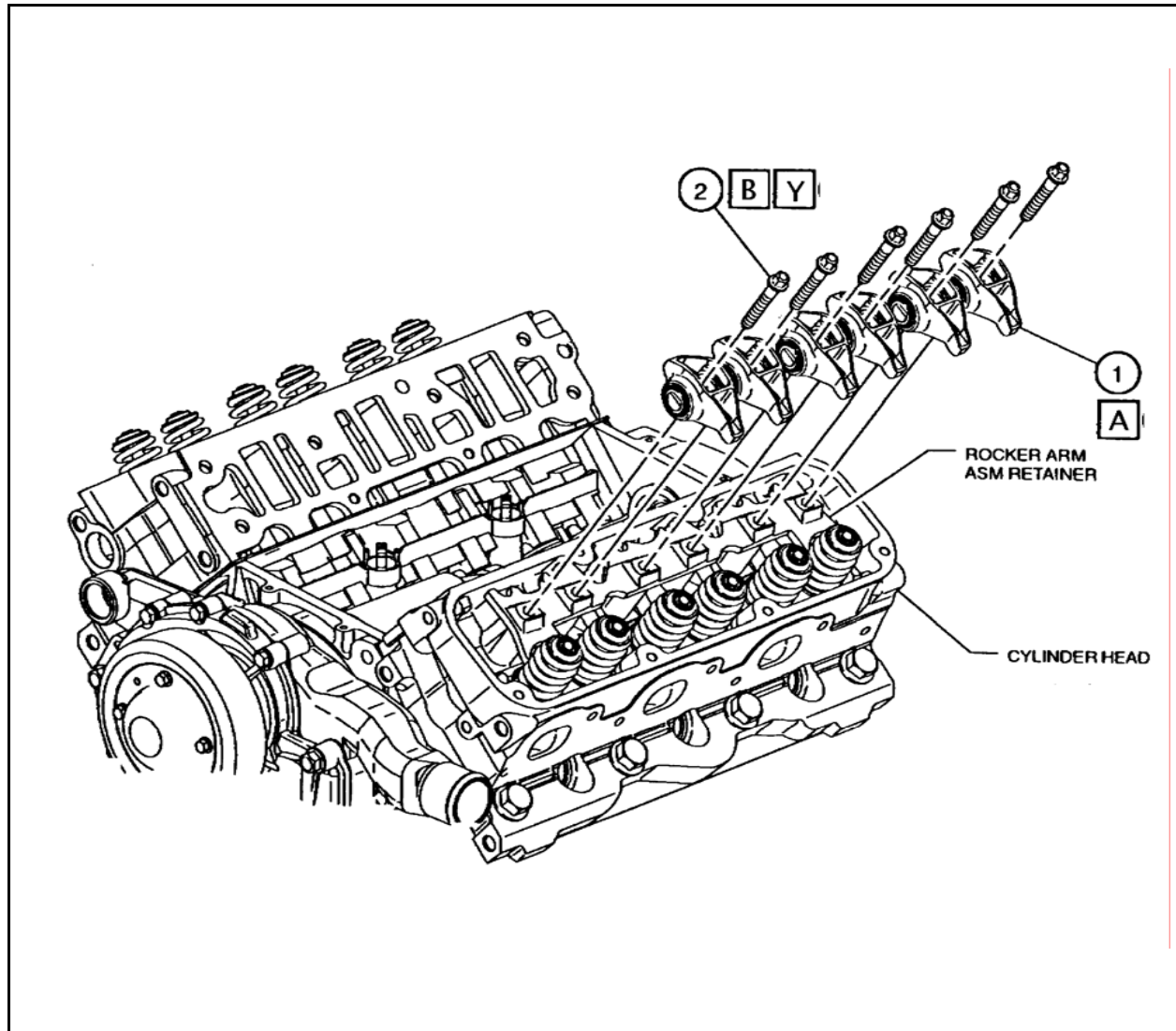

Description of Operation	
A	Lubricate rocker arms with EF-411 and install. Note: Rocker arm assemblies are replaced every test. Do not dip or spray with degreasing solvent. Needle roller bearings will retain solvents.
B	Lubricate bolts with EF-411 and install.
Y	Torque & Angle 25Nm + 70° Note: Do not rotate engine after final valvetrain loading.

Specification	
1	OHT3F-058-1 Rocker Arm Assembly
2	Furnished less sealers with OHT Kit

REV	Date	Revision History
1	1/6/1998	Block-42
2	12/15/03	Update, change to mineral spirits
3	7/20/06	Update, change to degreasing solvent

View	
Rocker Arm	
Rocker arm installation	

Long Block Assembly

Sequence III G

Section	Sheet
6	4

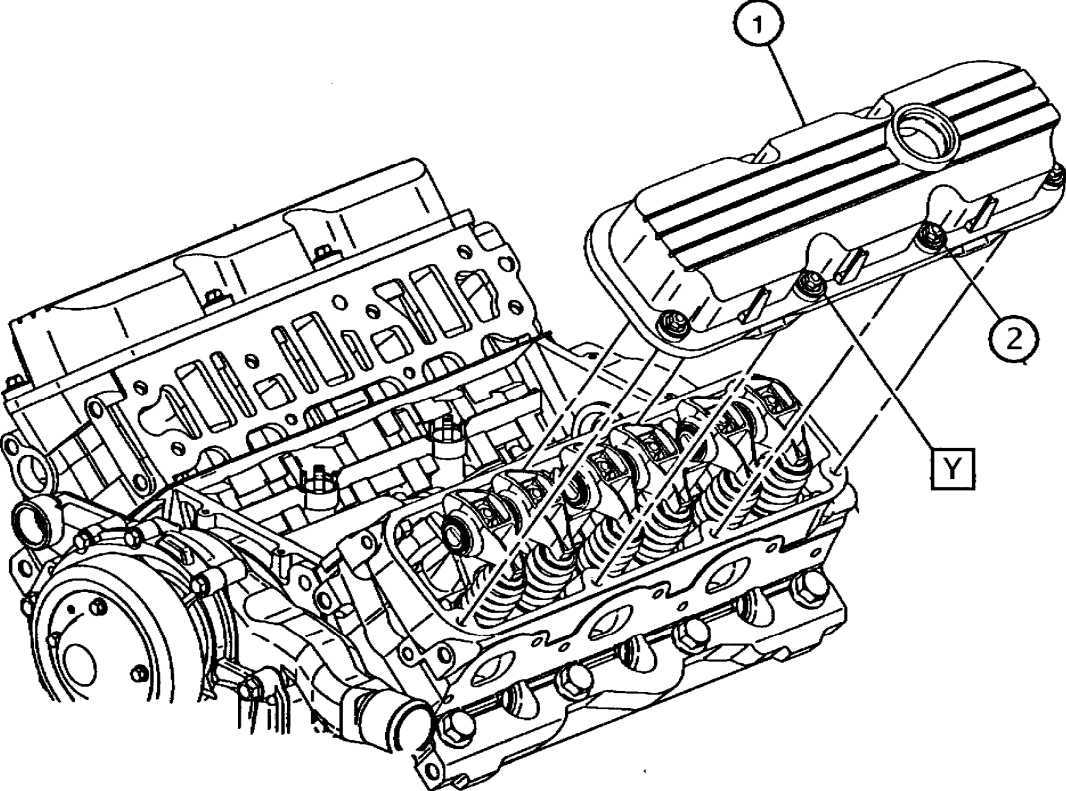
			Description of Operation		
					Install rocker covers Y Torque 10Nm
			Specification		
			1	12590366 Cover, Valve Lt (2)	
			2	24502164 Bolt 25534749 Grommet	
			3	25532619 Gasket (Not Shown)	
Revision History			View		
REV	Date		Rocker Cover		
1	1/6/1998	Block-43	Rocker cover installation		
2	3/30/07	Update Rocker Cover part number new 12590366 old 25534751			
3	7/1/11	Deleted bolt with washer, part number 25534748 and added Grommet, P/N 25534749			
Long Block Assembly		Sequence III G		Section	Sheet
				6	5

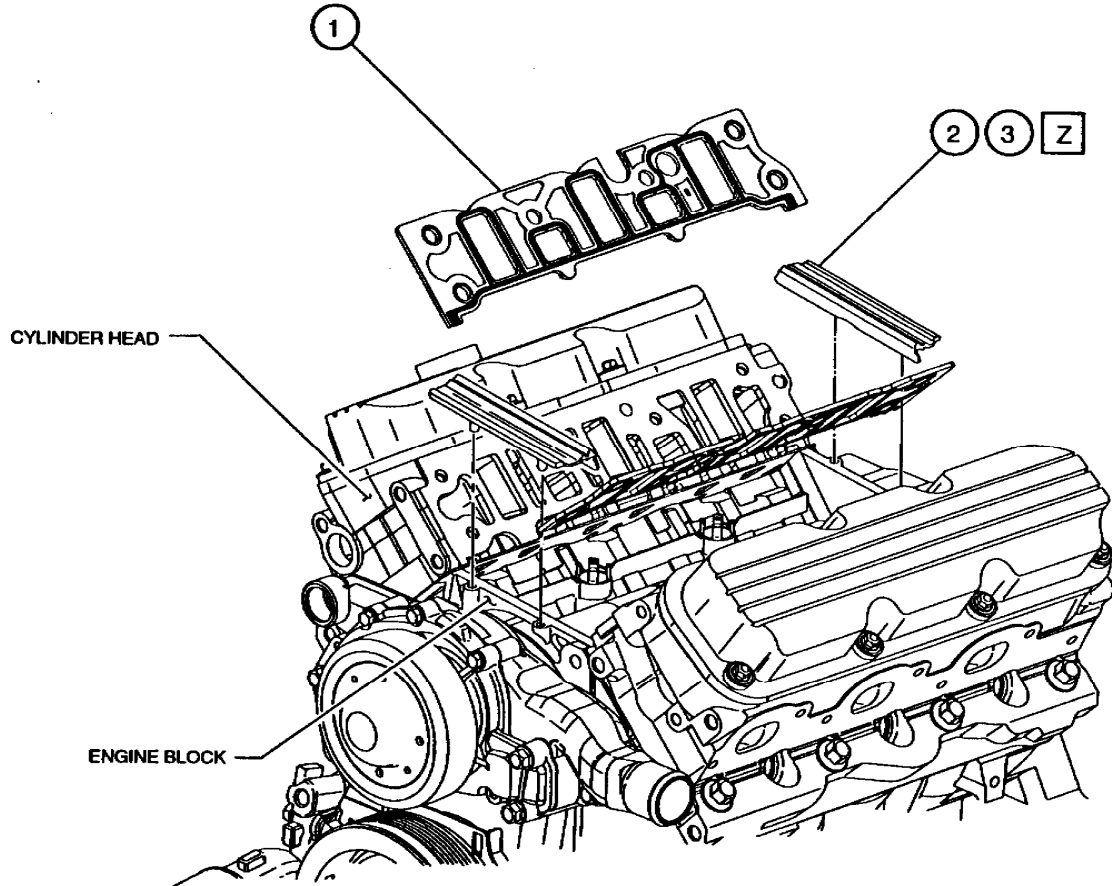

Description of Operation

2nd design gasket kit uses locating pins for front and rear seals

Z Apply RTV, GM (see part number info) or Dow Corning® 3154 RTV MIL-A46146 adhesive/Sealer to both ends.

GM Silicone Sealer
 New numbers:
 12378577 Tube
 12551715 Cartridges

Specification

- 1 89017816
 89017399 (Old)
 12480830 (Old)
 All part numbers are good
- 2 Seal / part of kit
- 3 Sealant (see note Z)

View

Intake Gaskets

Intake gasket installation

Section

6

Sheet

6

REV	Date	Revision History
1	1/6/1998	Block-44
2	12/15/03	Update RTV sealer
3	3/15/04	Update Intake Gasket Part Number and Silisone Sealer Information
4	7/20/06	Update Intake Gasket Part Number
5	7/1/11	Update RTV sealer

Long Block Assembly

Sequence III G

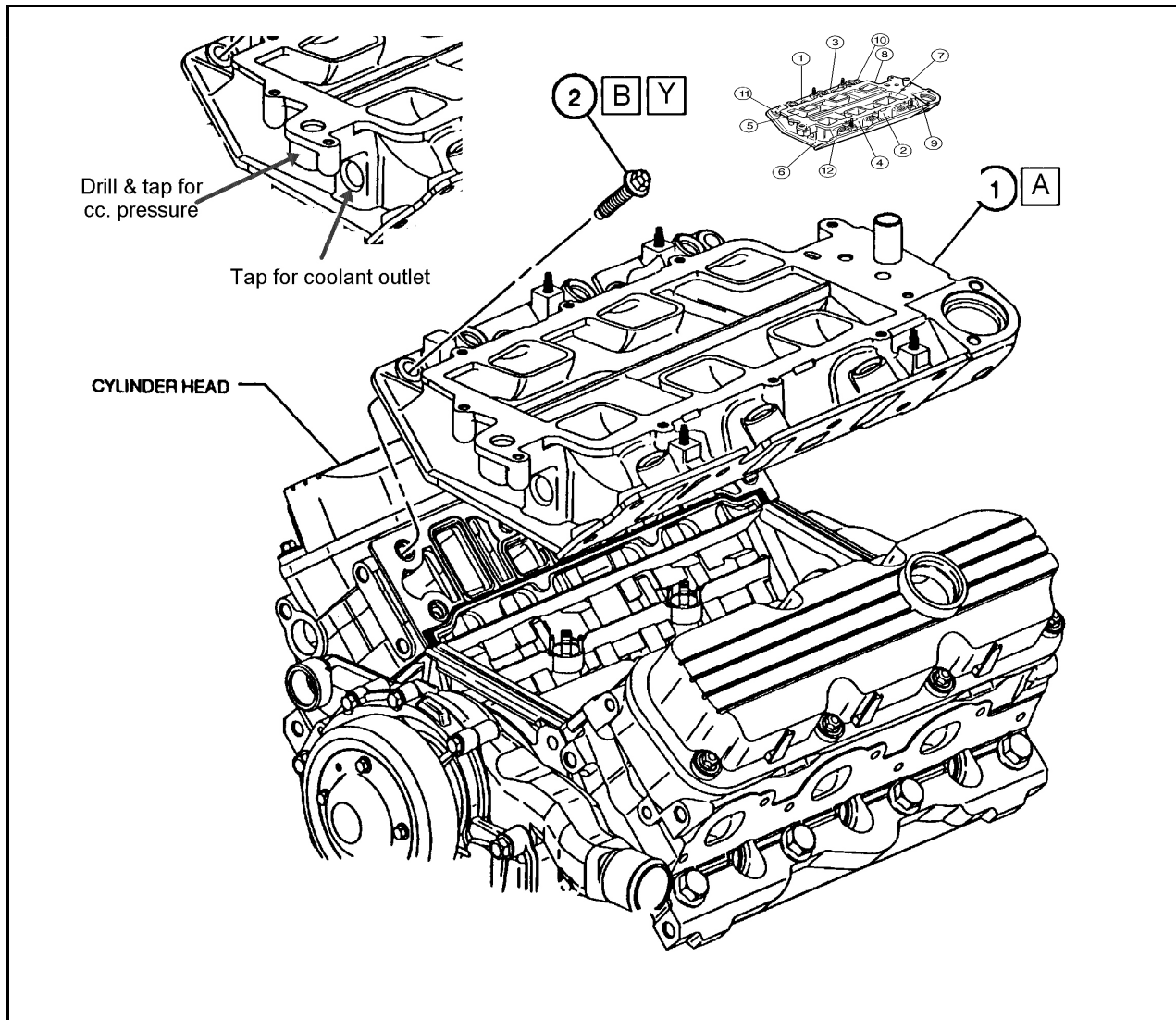

Description of Operation	
A	Install modified intake manifold
B	Clean and lubricate bolts with Permatex #2 or RTV (see sec. 6 sheet 6 for RTV information) and install.
Y	Torque 15Nm Drill and tap as indicated for the crankcase pressure line . Also tap coolant outlet port for coolant return line to process controller. Use a 3/4" I.D. unrestricted line for the return. Do not install shut off valves in the return line.

Specification	
1	24508923 Manifold, lower intake
2	9440227 Bolt (12)

REV	Date	Revision History
1	1/6/1998	Block-45
2	7/1/2011	Revised Intake Manifold description and part number and add torque sequence

View	
Lower Intake	
Lower intake manifold installation	

Long Block Assembly	Sequence III G
----------------------------	-----------------------

Section	Sheet
6	7

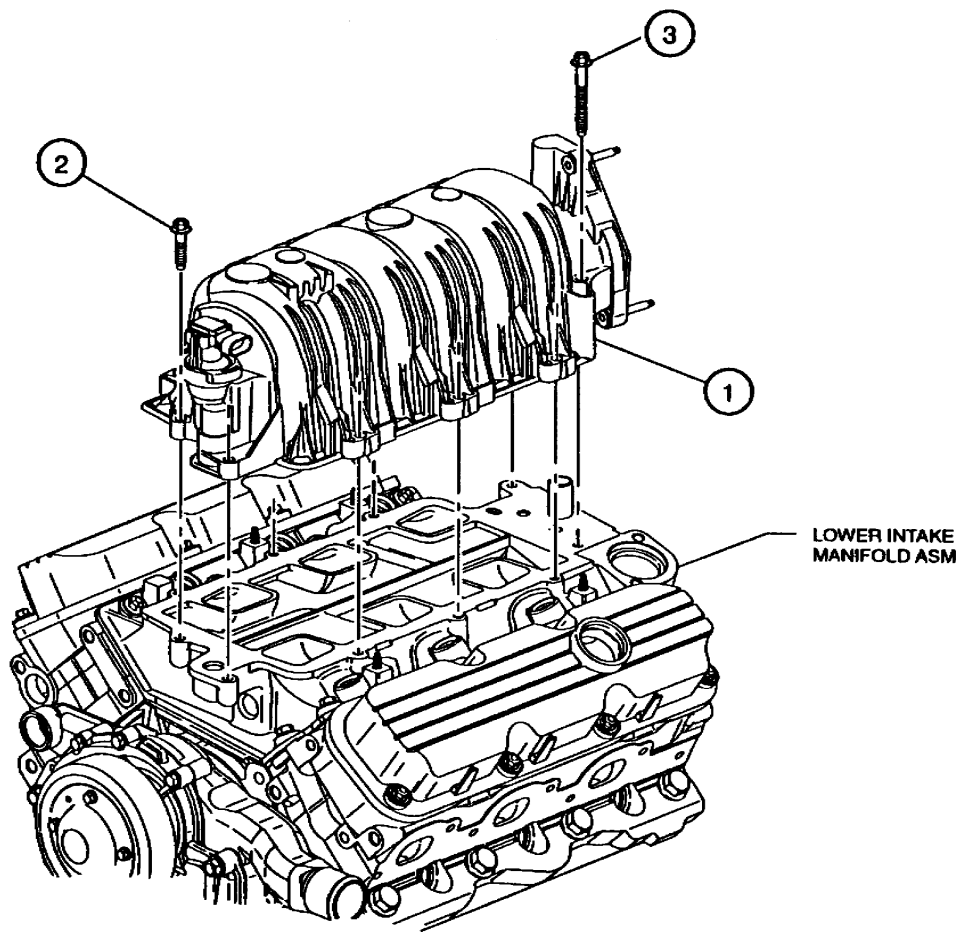

Description of Operation

Install upper intake and gasket assembly.

Torque 10Nm (Max. torque)

Y

Specification

1 89017272 Manifold kit, Upper Intake
89017556 Gasket Kit

2 24506498 Bolt (8)

3 24505205 Bolt (2)

See note Y for torque

View

Upper Intake

Upper intake installation

Section

6

Sheet

8

REV	Date	Revision History
1	1/6/1998	Block-46
2	3/30/07	Update upper intake gasket part number new 89017556 old 17113137
3	2/20/10	Removed stud (number 3) and renumbered 4 as 3
4	7/1/11	Revised description and updated part number

Long Block Assembly

Sequence III G

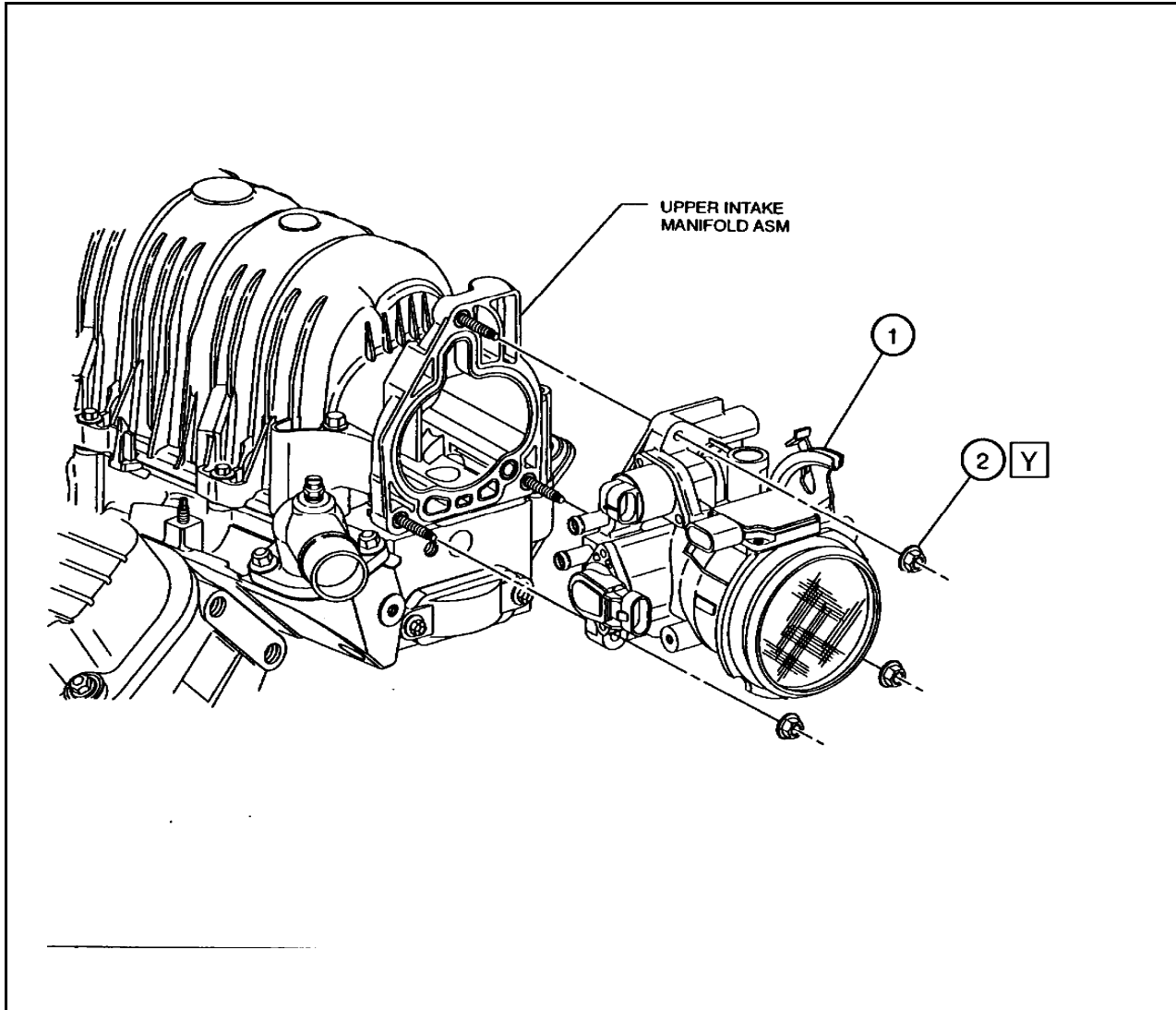

Description of Operation	
	Install modified throttle body
	Note: See section 7 sheet 5 for modifications
Y	Torque 10Nm

Specification	
1	24507235 Throttle Body
2	24506469 Nut

REV	Date	Revision History
1	1/6/1998	Block-47
2	4/28/03	Add new mass airflow part number 12568877
3	6/23/03	Add 88961007 remanufactured from 12568877
4	7/1/11	Removed 88961007 remanufactured from 12568877

View	
Throttle Body	
Throttle body installation	

Long Block Assembly	Sequence III G
----------------------------	-----------------------

Section	Sheet
6	9

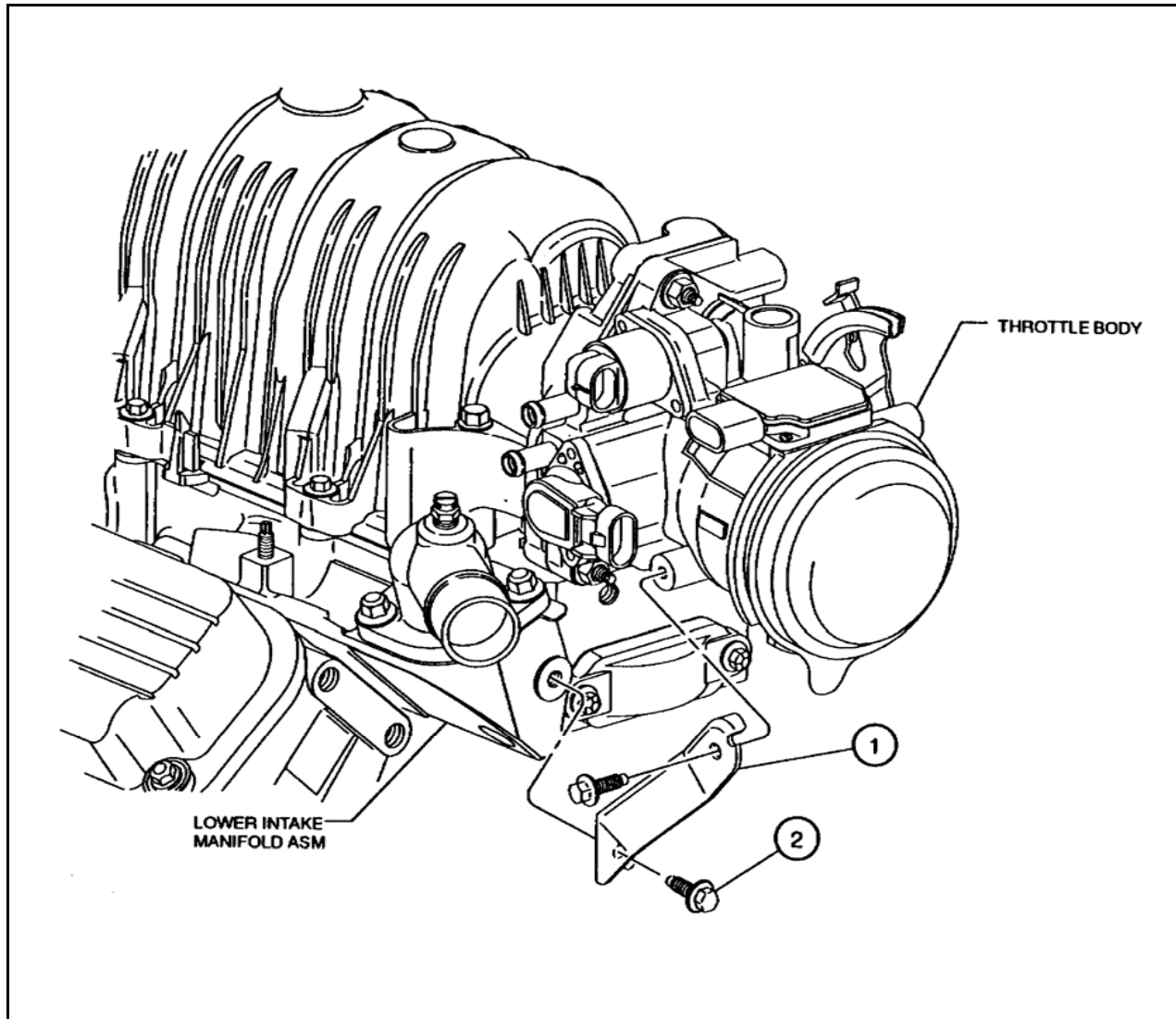

Description of Operation	
	Install support bracket
Y	Torque 10Nm

Specification	
1	24504697 Support
2	24503644 Bolt (2) See note Y for torque

REV	Date	Revision History
1	1/6/1998	Block-48

View	
Throttle Body Support	
Throttle body support installation	

Long Block Assembly

Sequence III G

Section	Sheet
6	10

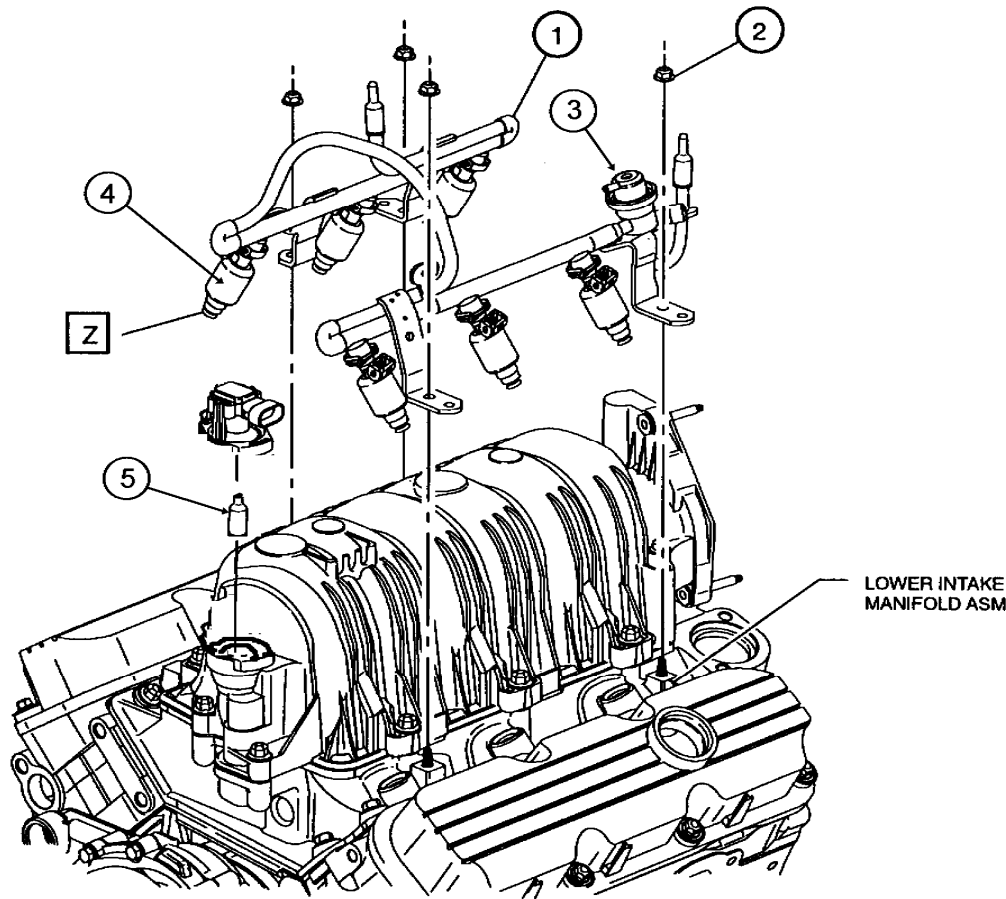

Description of Operation

Install injector assembly (See sec. 6.14.1 of the test procedure for injector flow testing requirements).

Y Torque 10Nm

Z Lubricate O-ring with EF-411

Specification

- 1 12587077 Rail, Fuel Injector
- 2 24506469 Nut
- 3 89017530 or 89060416 Regulator
- 4 17120601 Injector
- 5 OHT3F-002-1 PCV Dummy

View

Injector Assembly

Injector assembly installation

Section

6

Sheet

11

REV	Date	Revision History
1	1/6/1998	Block-49
2	12/15/03	Update text on reference to procedure for injector flow testing requirements
3	7/1/11	Updated part number for fuel injector rail and added second pressure regulator

Long Block Assembly

Sequence III G

Section 7

Final Dress

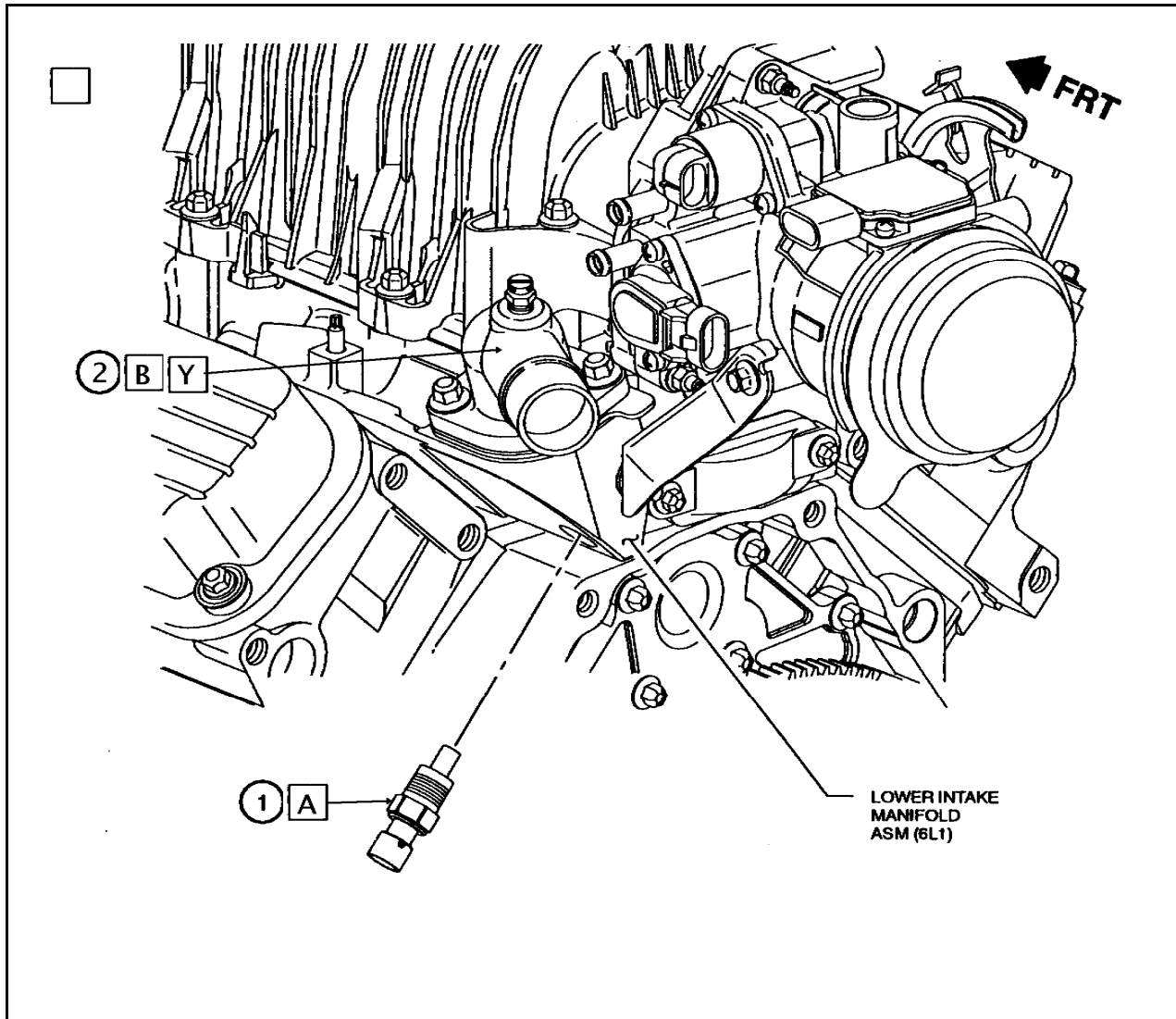

Description of Operation	
A	Install production sensor as a plug only. <u>Do not use for connection to harness. Disable connector.</u>
B	Install coolant outlet using gasket 24502433
Y	Torque 27Nm

Specification	
1	10096181 Sensor (Used for plug only, disable connector)
2	OHT3F-034-1 Coolant Outlet and Gasket 24502433 (Not to detail on sheet)

REV	Date	Revision History
1	1/10/98	Block-51
2	7/1/11	Added coolant outlet gasket part number

View	
Coolant Out & Sensor	

Final Dress	Sequence III G
--------------------	-----------------------

Section	Sheet
7	1

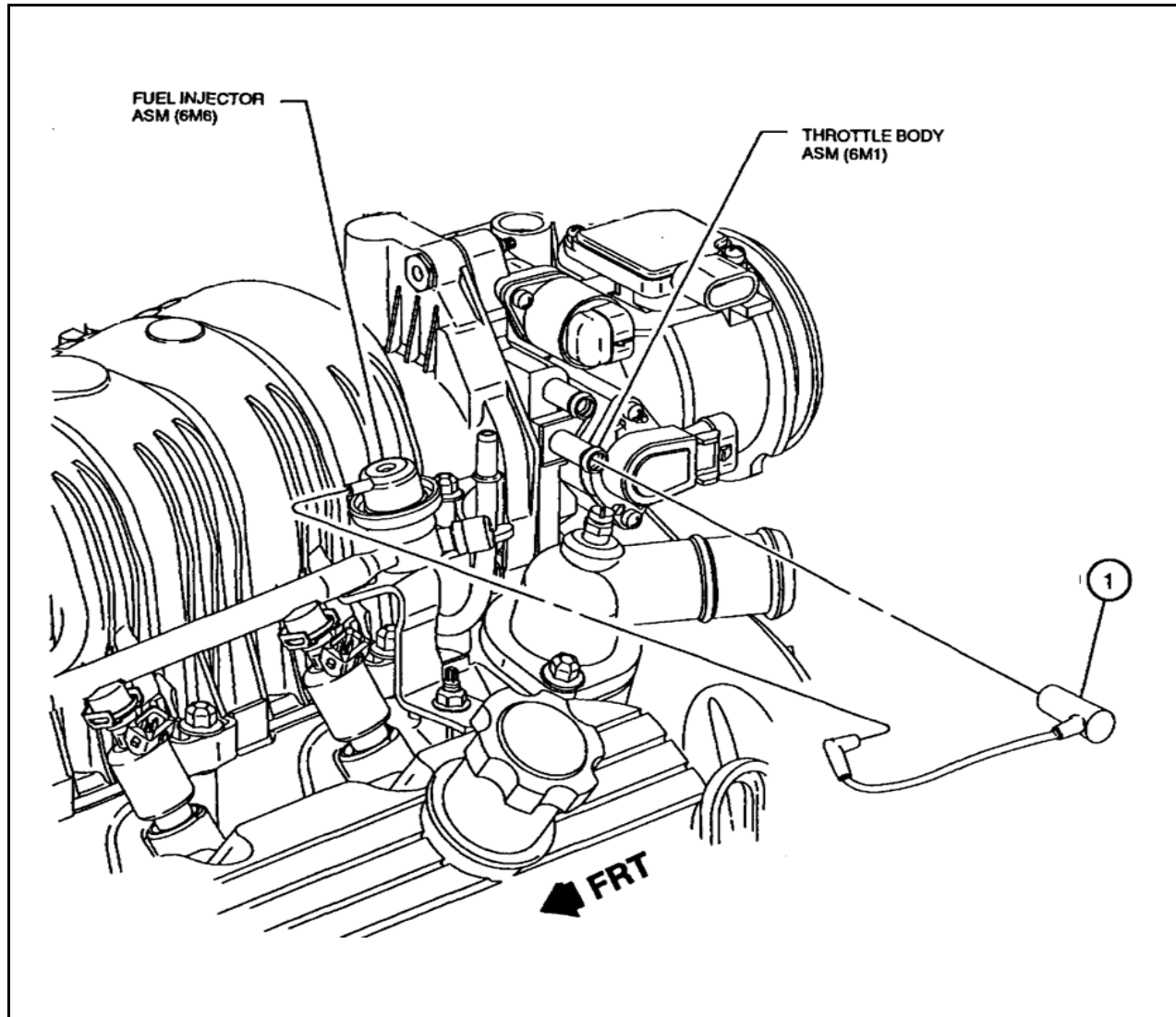

Description of Operation

Specification

1 24505671 Tube

REV	Date	Revision History
1	1/10/98	Block-52

View

Vacuum Hose

Final Dress

Sequence III G

Section

7

Sheet

2

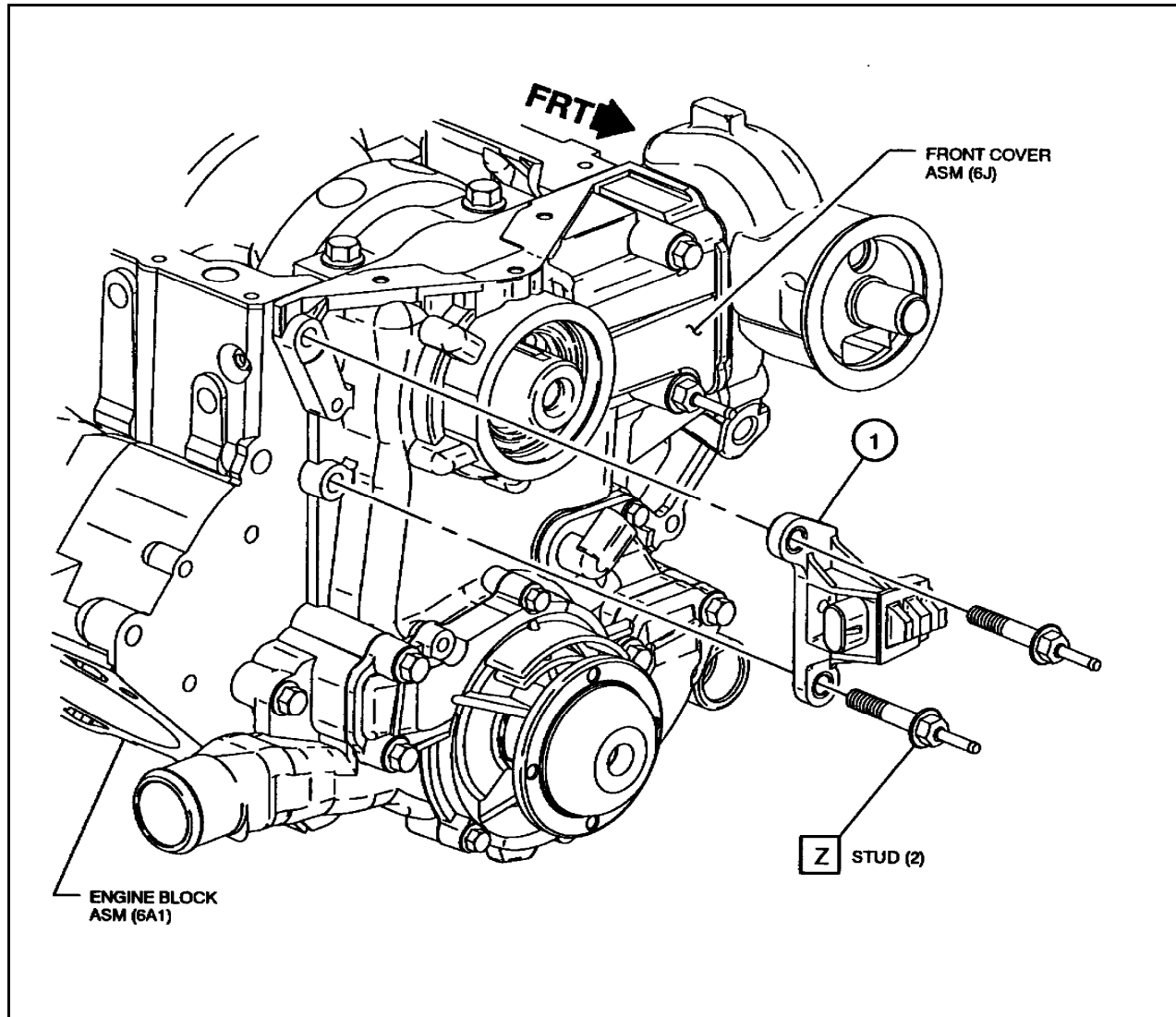

Description of Operation

Z See front cover section for bolt part numbers and torque.

Specification	
1	10456161 Sensor

REV	Date	Revision History
1	1/10/98	Block-53

View
Crankshaft Sensor

Final Dress **Sequence III G**

Section	Sheet
7	3

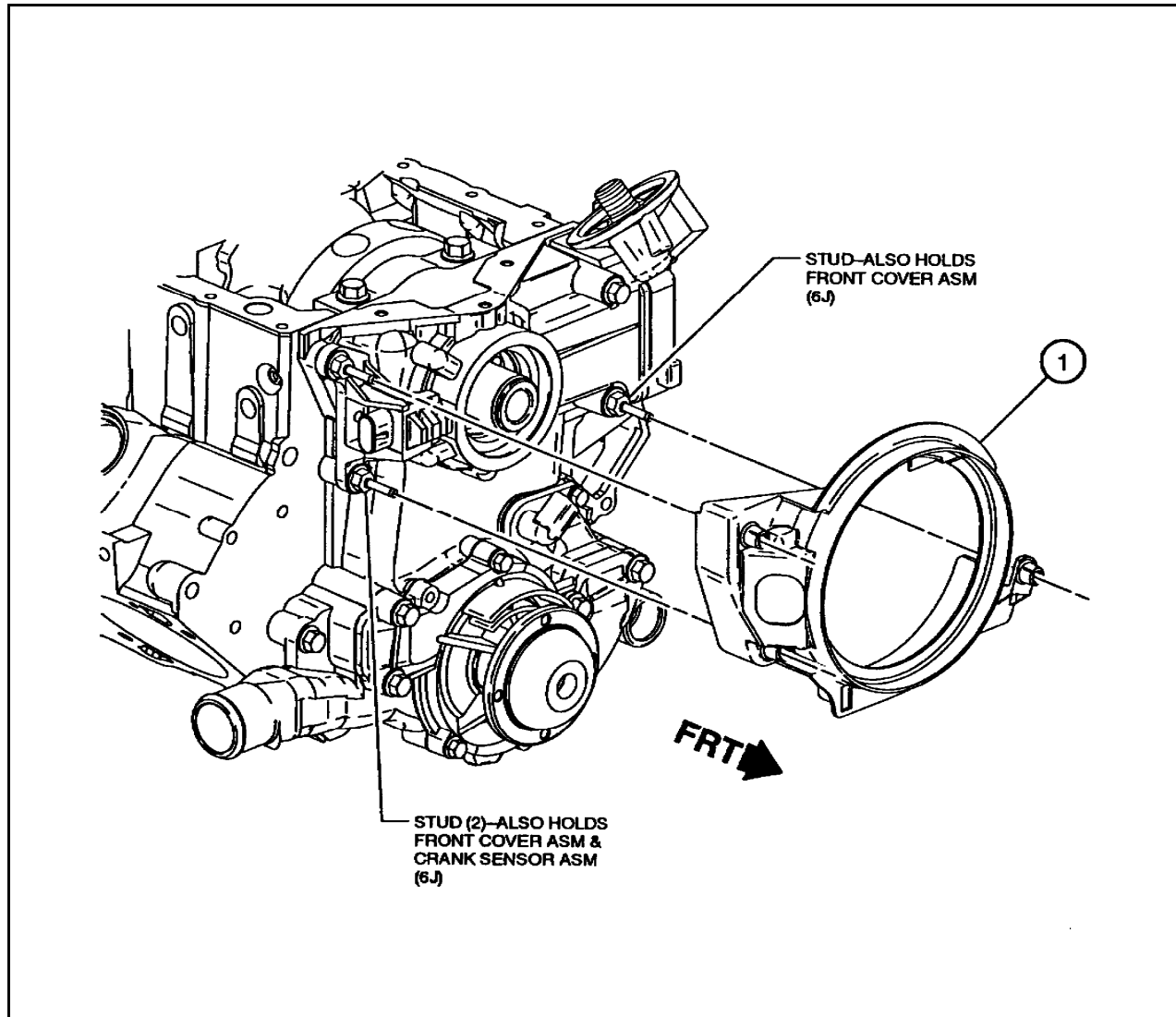

Description of Operation

Specification

1 24506440 or 12591982 Shield

REV	Date	Revision History
1	1/10/98	Block-54
2	12/15/03	Add 24508586
3	7/1/11	Part Number Change 12591982 replaces 24508586

View

Crankshaft Sensor Shield

Final Dress

Sequence III G

Section

7

Sheet

4

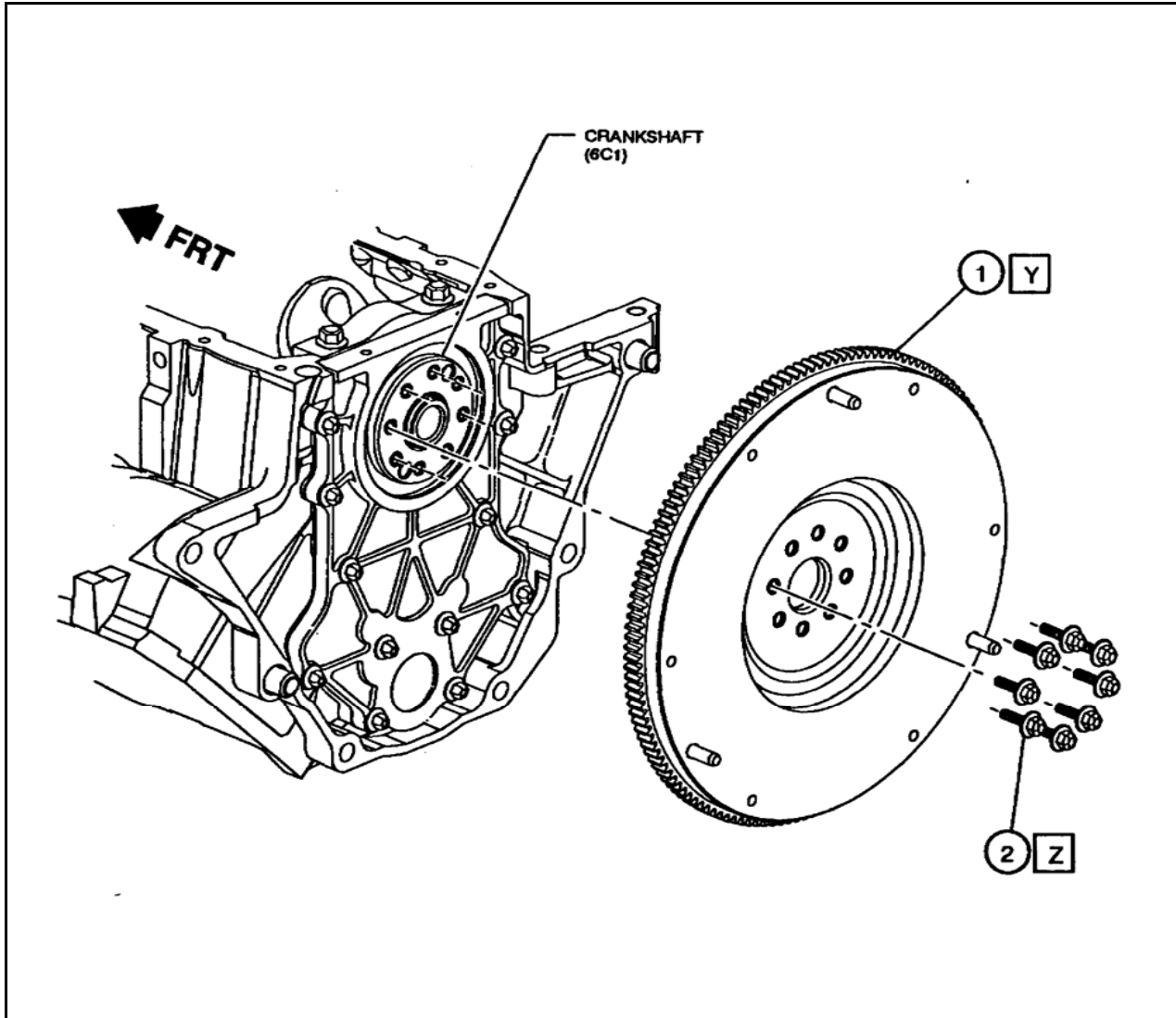

Description of Operation	
Y	OHT-020-2 modified to fit offset balance and adapter plate for Dana 1550 four bolt yoke.
Z	Torque & Angle 15Nm + 50°

Specification	
1	OHT3F-020-2 Flywheel (Modified 24503285)
2	24505092 Bolt

REV	Date	Revision History
1	1/10/98	Block-55

View	
Flywheel	

Final Dress	Sequence III G
-------------	----------------

Section	Sheet
7	5

			Description of Operation	
			A	Drill and tap to receive a hex head plug
			B	Use power to PCM with engine not running and throttle blade open to drive Idle Air Control motor closed. Disconnect harness connector and adjust idle screw to obtain 800 RPM base idle. As an alternative, the IAC may be removed and both ports plugged using epoxy and welch type plugs.
			Specification	
			1	24507235 Throttle Body (2 bolt Mass Air Flow Sensor)
REV	Date	Revision History	View	
1	11/13/99	Block-48	Throttle Body Modification	
2	5/28/03	Add 12568877		
3	6/23/03	Add 88961007 remanufactured from 12568877		
4	7/1/11	Removed 88961007 and 12568877		
			Section	Sheet
Final Dress		Sequence III G	7	6

Section 8

OH Technologies Special Engine Dress

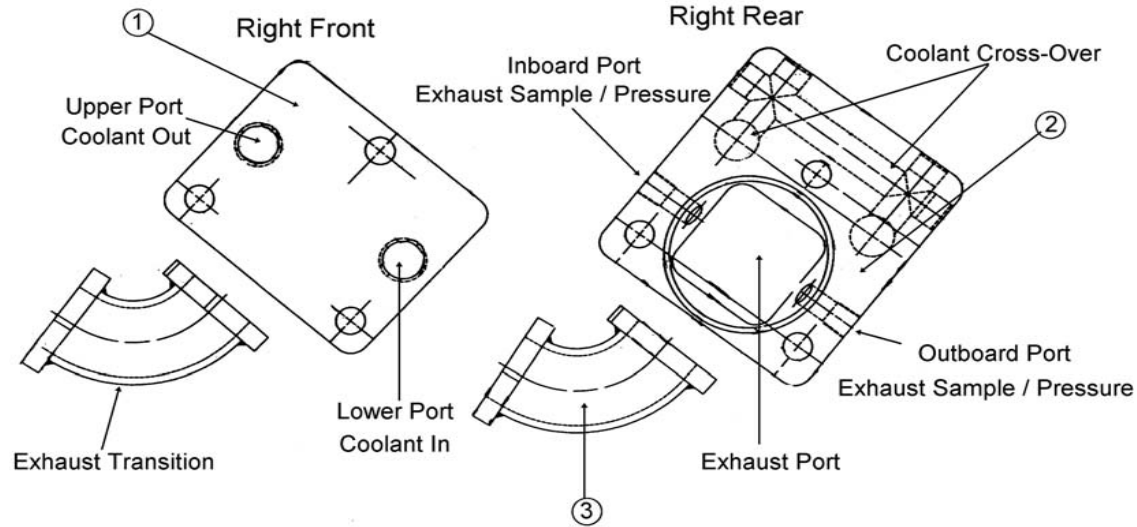

Description of Operation

Water cooled exhaust manifold end plates and exhaust manifold transitions. Note: both views are right side showing the cooling water inlet is the lower port and the outlet is the higher port. Also, the inboard exhaust sample port is typically for the gas analysis and the outboard is for the back pressure connection.

The transition should be connected with shielded gaskets not shown but identified by part number. Two required per side.

Thermocouples for exhaust coolant in and out should be installed in the fittings attached to the front plate and centered in the coolant flow.

Specification

- 1 OHT3F-006-1 Plate, Rear Exhaust
- 2 OHT3F-005-1 Plate, Front Exhaust
- 3 OHT3F-004-1 Runner, Exh. Man.

REV	Date	Revision History
1	11/13/99	Block-60
2	2/22/02	Update View Exhaust sample / pressure locations

View

Water Cooled Exh. Man. End Plates

OHT	Sequence III G
------------	-----------------------

Section	Sheet
8	1

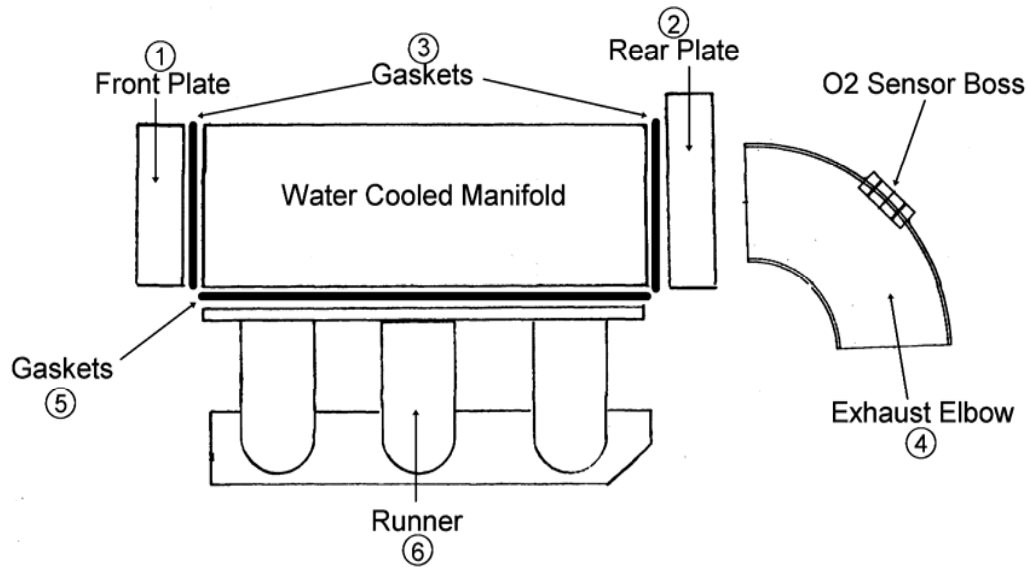

Description of Operation

Water cooled exhaust manifold

Not to scale

Note: Do Not Use RTV Sealer on O2 sensor or other exhaust system components upstream of O2 sensor.

Specification

- 1 OHT3F-005-1 Plate, Front Exhaust
- 2 OHT3F-006-1 Plate, Rear Exhaust
- 3 OHT3F-009-1 Gasket, End Plate
- 4 OHT3F-005A-1 Elbow, Exh. Modified
- 5 OHT3F-018-1 Gasket Flange, Metal
- 6 OHT3F-004-1 Runner, Exh. Man.

View

Water Cooled Exh. Man. & Elbow

REV	Date	Revision History
1	11/13/99	Block-61
2	2/22/02	Update text, include warning on usage of RTV sealer

OHT

Sequence III G

Section	Sheet
8	2

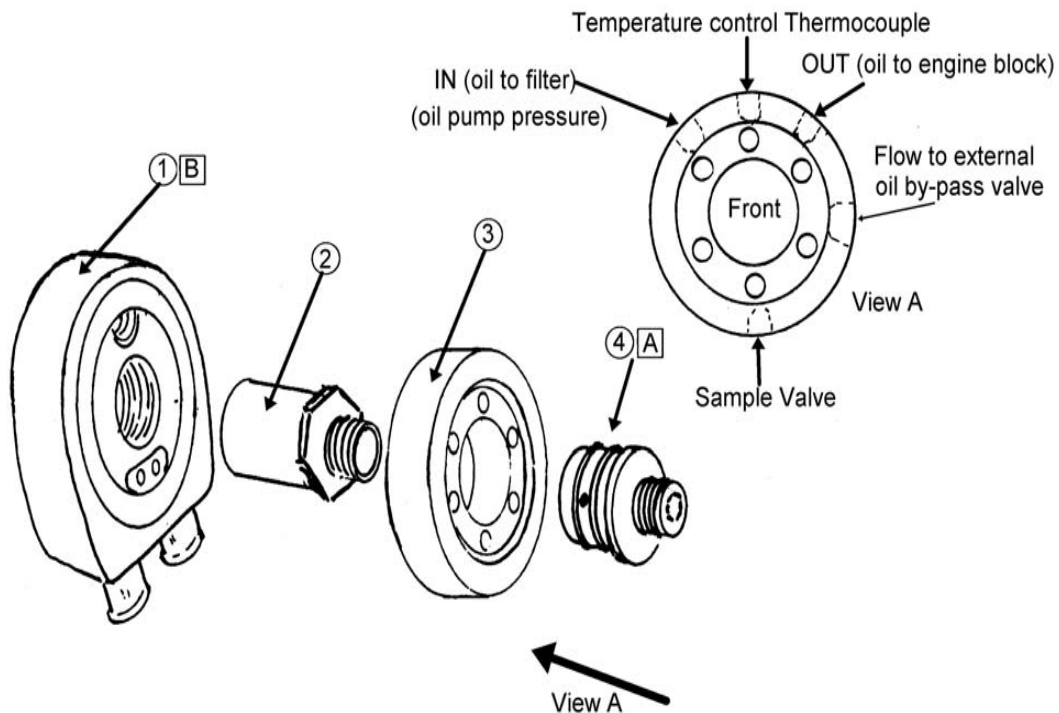

Note: See section 8 sheet 3a & 3b for additional information

Description of Operation

- A Replace "O"-rings every test.

Note: View A
Viewed from front or oil filter side, passages are, IN (oil pump pressure to filter), center port for temperature control thermocouple, OUT (oil flow out of filter in to engine block), Side outlet to external oil by-pass valve, and lower port is for oil sample valve.
- B Replace oil cooler every test

Specification

- 1 OHT3F-030-2 Cooler Nickel Plated
- 2 OHT3F-039-3 Connector Special Cut
- 3 OHT3F-035-2 Adapter, Oil Filter
- 4 OHT3F-043-2 Fitting, Oil Filter Adapter

REV	Date	Revision History
1	11/30/99	Block 62
2	6/17/02	Add notes, new part numbers and update view. See next sheet for further details

View	
Oil Cooler Assembly	

OHT	Sequence III G
------------	-----------------------

Section	Sheet
8	3

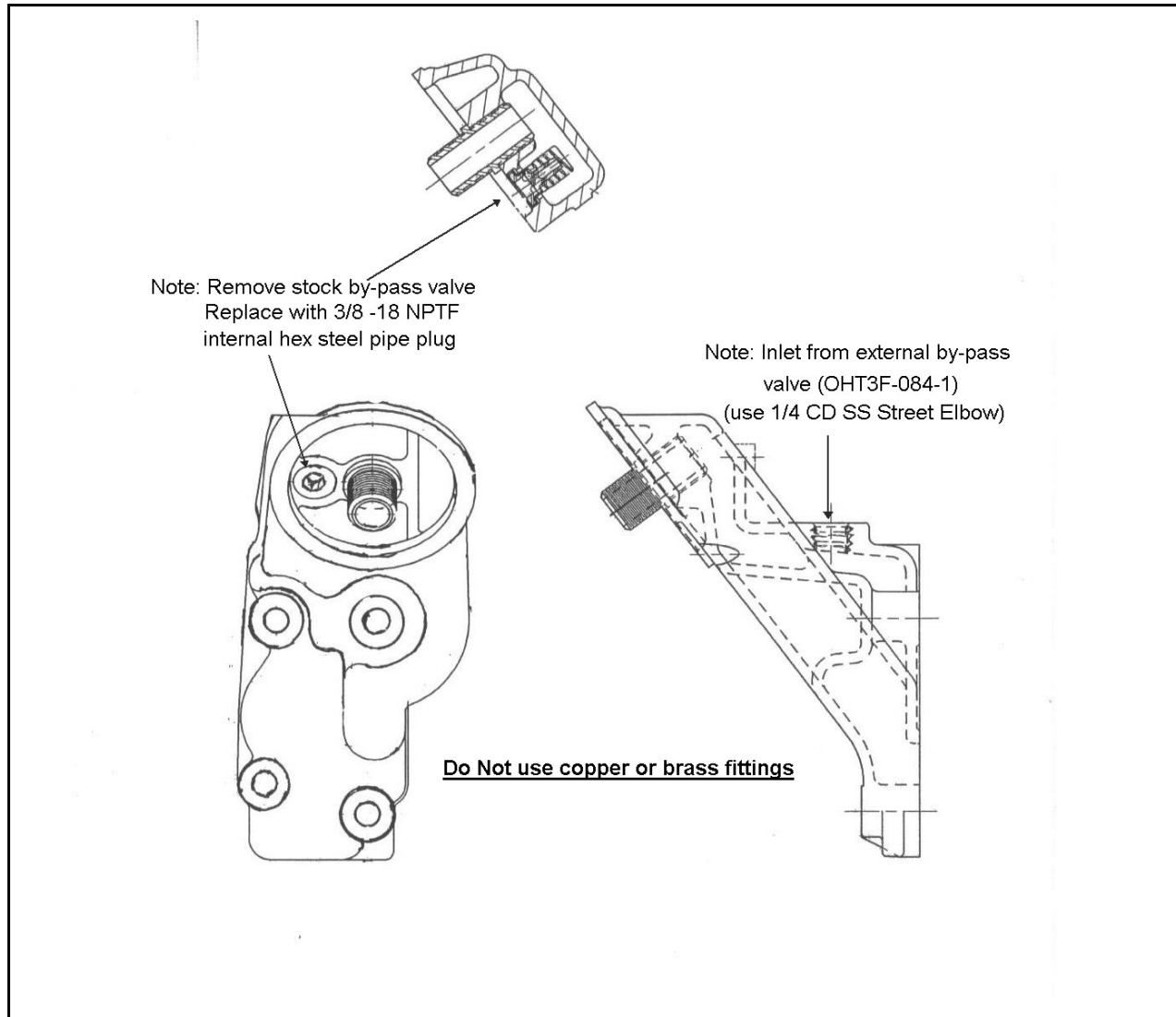

Description of Operation

Special part modification information.

Modified part may be purchased direct from OHT (OHT3F-080-1)

Specification

1	24501300 Adapter, oil filter OHT3F-080-1 Modified
---	--

REV	Date	Revision History

View

Oil Filter Adapter Modification

OHT

Sequence III G

Section
8

Sheet
3a

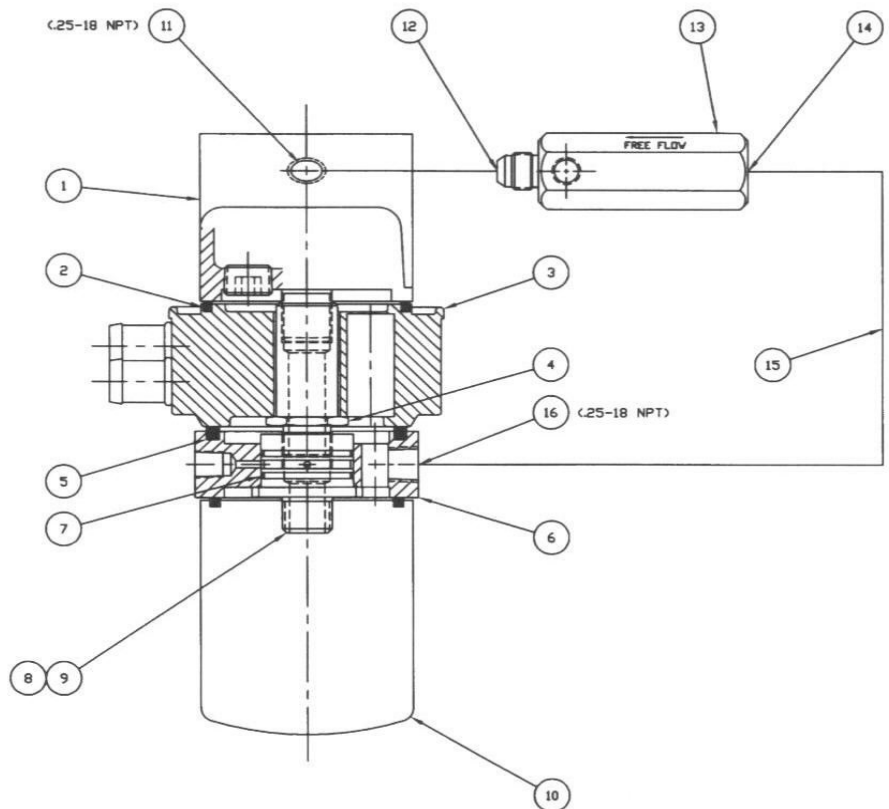

BILL OF MATERIAL		
ITEM	REQ'D	DESCRIPTION
1	1	BLOCK, OIL FILTER, MODIFIED W/BYPASS BLOCKED, DHT3F-080-1
2	1	SEAL, RECTANGULAR, DHT3F-074-1
3	1	COOLER, OIL, NICKEL PLATED, BYPASS CLOSED, DHT3F-030-2
4	1	CONNECTOR, MODIFIED, DHT3F-039-3
5	1	SEAL, RECTANGULAR, DHT3F-062-1
6	1	ADAPTER, OIL FILTER, DHT3F-035-2
7	2	SEAL, O-RING, #2-025-VITON PARKER
8	1	FITTING, OIL FILTER ADAPTER, .500" I.D., DHT3F-043-2
9	1	WRENCH, SPANNER, (FOR USE W/ITEM #8), DHT3F-083-1
10	1	FILTER, OIL (PF-47), DHT3F-057-1
11	1	ELBOW, STREET, #1/4 CD-SS PARKER
12	1	CONNECTOR, SWIVEL, #6 F6X-SS PARKER
13	1	HOUSING, ASS'Y, BYPASS VALVE, DHT3F-084-1
14	1	CONNECTOR, MALE, #6-8FTX-SS PARKER
15	1	(.31 I.D. X 12.00 LG.) BRAIDED TEFLON HOSE ASS'Y, #K9190606-060606C-012.0 PARKER
16	1	CONNECTOR, MALE, #6FTX-SS PARKER

ASSEMBLE ALL SEALS WITH A LIGHT COATING OF #EF411 OIL

DIMENSIONS IN PARENTHESES ARE IN INCHES

© COPYRIGHT OH TECHNOLOGIES, INC., 2002
ALL RIGHTS RESERVED

METRIC		SYM	REVISES	DATE
UNLESS OTHERWISE SPECIFIED DIMENSIONS ARE IN MILLIMETERS				
TOLERANCES UNLESS SPECIFIED	TITLE	ASS'Y, OIL FILTER, COOLER & BYPASS		
DECIMAL	NATURAL	SEE B/M		
XX = .003	SCALE	FULL	CHECKED BY	DRAWN BY
XXX = .010	DATE	6-6-02	D.H.	ASSEMBLY
ANGULAR .15				
SURFACES 1/2				
OH TECHNOLOGIES INC.		DWG. NO.	DHT3G-XXX-1	
P.O. BOX 1000		MONTICELLO, NY 12548		

REV	Date	Revision History	View	
1	6/17/02	OHT Print	OHT Oil Cooling & By-Pass	
			Printed by permission OH Technologies	
			Section	Sheet
			8	3b
OHT		Sequence III G		

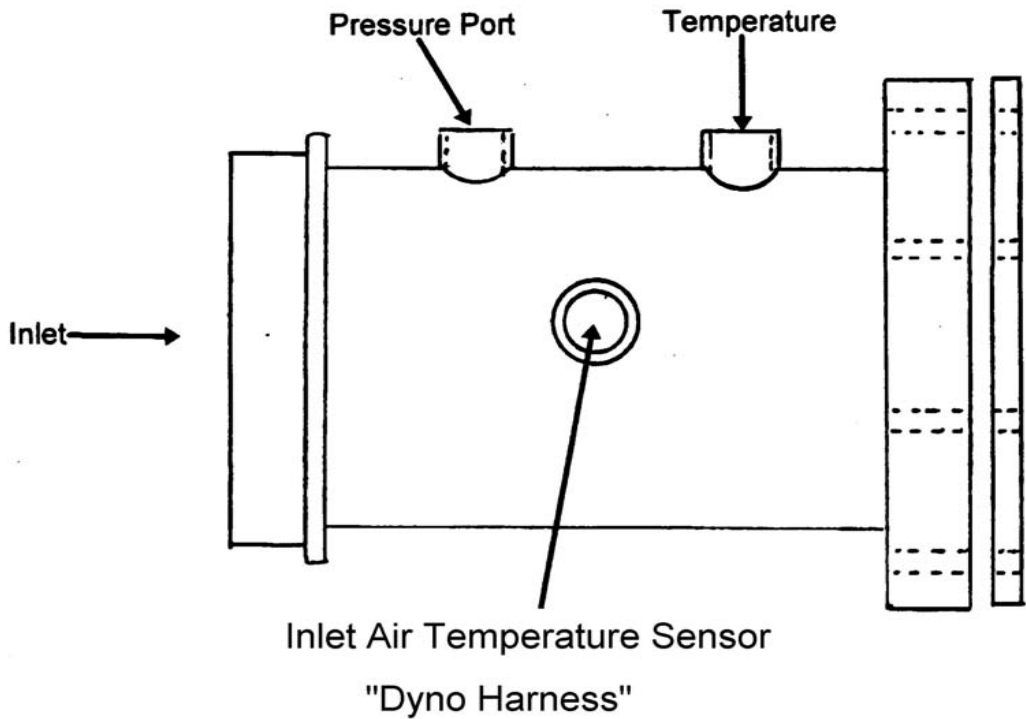

Description of Operation

Inlre air adapter
 Use pressure port for hookup to transducer, temperature for thermocouple (centered in flow), and inlet air pressure sensor port for Dyno Harness sensor.

Specification

OHT3F-001-2 Adapter, Throttle Body

REV	Date	Revision History
1	11/30/99	Block-63
2	2/22/02	Update View, Inlet Air Temp. Sensor

View

Adapter, Throttle Body

OHT

Sequence III G

Section

8

Sheet

4