



Test Monitoring Center

Carnegie Mellon University
6555 Penn Avenue, Pittsburgh, PA 15206, USA

<http://astmtmc.cmu.edu>
412-365-1000

Sequence IIIF Information Letter 11-1
Sequence No. 33
Corrected September 30, 2011

ASTM consensus has not been obtained on this information letter. An appropriate ASTM ballot will be issued in order to achieve such consensus.

TO: Sequence III Mailing List

SUBJECT: 1. Changes to Engine Oil Cooling System
2. Corrected NAT 50/PDN 50 Concentration

1. During the August 10, 2011 Sequence III Surveillance Panel Conference call, the panel approved a change to the engine oil cooling system. The system now requires an additional heat exchanger. Section 6.10 has been revised to include this new tube-and-shell heat exchanger. Table A14.1 has also been revised to reflect the tube-and-shell heat exchanger and Annex A15 has been added to show the schematic of the engine oil cooling loop. An updated Table of Contents has also been included, which also corrects a numbering discrepancy and omitted Annex in the current version.

2. During the same conference call, the panel agreed to correct an error in the concentration level of the NAT-50/PDN-50 soap used for engine block cleaning. Section 9.5.3.1 (1) has been revised to reflect a concentration of 0.73 kg per 38 liters and to change the solution every three months.

The attached changes to Test Method D 6984 are effective August 10, 2011.

Bruce Matthews
Engine Oil Test Development and Support
GM Powertrain Materials Engineering

Frank M. Farber
Administrator
ASTM Test Monitoring Center

Attachments

c: ftp://ftp.astmtmc.cmu.edu/docs/gas/sequenceiii/procedure_and_ils/IIIF/IL11-1.pdf

Distribution: Electronic Mail

Modifies Test Method D6984-11

Annexes

The Role of the ASTM Test Monitoring Center (TMC) and the Calibration Program	Annex A1
Sequence IIIF Test Parts Replacement Guidelines	Annex A2
Sequence IIIF Determination Volume of Engine Oil in Pan	Annex A3
Sequence IIIF Test Fuel Analysis	Annex A4
Sequence IIIF Test Reporting	Annex A5
Sequence IIIF Test Air-to-Fuel Ratio Control Flow Chart	Annex A6
Sequence IIIF Test Set Points and Control States	Annex A7
Sequence IIIF Quality Index Upper and Lower Values	Annex A8
Sequence IIIF Engine Oil Level Worksheet	Annex A9
Engine Build Worksheets	Annex A10
Blowby Flow Rate Determination	Annex A11
Safety Precautions	Annex A12
Sequence IIIF Blueprint Listing	Annex A13
Fluid Conditioning Module Components	Annex A14
Engine Oil Cooling System Schematic	Annex A15
Appendix	
Sequence IIIFHD Test Procedure	Appendix X1
Sequence IIIFVIS Test Procedure	Appendix X2

6.10 *Engine Oil-Cooling System*--The system consists of an oil filter adapter, engine-mounted oil cooler, gaskets as specified in the Engine Assembly Manual, Section 8 Sheet 3 & 3a and a shell-and-tube heat exchanger. The engine oil-cooling system uses engine coolant pumped from the Fluid Conditioning Module through a three-way control valve to the oil cooler circuit which contains a heat exchanger prior to the engine-mounted oil cooler. To maintain the specified oil temperature of 155 °C at the oil filter adapter, the three-way control valve varies the coolant flow as necessary through the oil cooler circuit. The heat exchanger in the oil cooler coolant circuit is a tube-and-shell style and will use process water as the cooling media (See Fig. A15.1). When testing high oxidation-sensitive oils, the oil cooling system may go into a bypass mode, causing the engine-mounted oil cooler to be by-passed. In this condition, the TMC may allow engineering judgment for the oil temperature Quality Index on reference oil tests.

9.5.3.1 Clean the block in a heated bath or temperature-controlled automated parts washer before and after honing. Follow these suggested guidelines as listed below to ensure there is no rusting of the engine block coolant jacket after this process:

(1) Use only NAT-50 or PDN-50 soap at a concentration of 0.73 kg of soap per 38 L of water. Change the soap and water solution at least every 3 months.

TABLE A14.1 List of Components that have been Found Suitable for Use in the Fluid Condition Module

System	Component	Make	Model	Comments
Fuel	Pump	KFI	10210	12 VDC
	Flow Meter	Micro Motion		
	Pressure Regulator (on-rack)	Weldon	2040-200-A-170	
	Heat Exchanger	Elanco	M11	
	Check Valve	Sharpe	FNW-16	
	Solenoid Valve	Skinner	72218RN4UV00N0H222P3	
	Filter	Racor	110A	
Engine Coolant	Pump	Aurora	341ABF 1-1/2 x 2 x 9	
	Flow Meter	ABB/Fisher Porter	10VT1000	1111ADH11C12AA0A has been replaced
	Heat Exchanger	Elanco	M71FL	
	Heater	Chromalox	ARTMS-1250TL	
	3-Way Control Valve	SVF	T7-6666TT150-S1	2 in. Valve
	2-Way Control Valve	Orion/Badger Meter	9003GCW36SV3A29L36	2 in. Valve (same as used on Sequence VIB)
	Inlet Line I.D. / Total Length	2 in.	226 in.	Total run from Process Controller to Engine Inlet Adapter
Breather Tube	Pump	Aurora	133-BF-E03 1-3/4 x 3/4	
	Flow Meter	Sparling	FM625*	
	Heat Exchanger	Elanco	M21	
	Heater	Chromalox	3CVCHS-151	
	3-Way Control Valve	SVF	T7-6666TTSE-S1	1/2-in. Valve
	2-Way Control Valve	SVF	V7-6666NTSE-V60	1/2-in. Valve
Oil Cooler	Pump	Aurora	133-BF-E03 1-3/4 x 3/4	
	Flow Meter	Sparling	FM625*	
	3-Way Control Valve	SVF	T7-6666TTSE-S1	1/2-in. Valve
	2-Way Control Valve	SVF	V7-6666NTSE-V30	1/2-in. Valve
	Heat Exchanger			Tube and shell nominally 3 in. dia. by 8 in.

A15. Engine Oil Cooling System Configuration

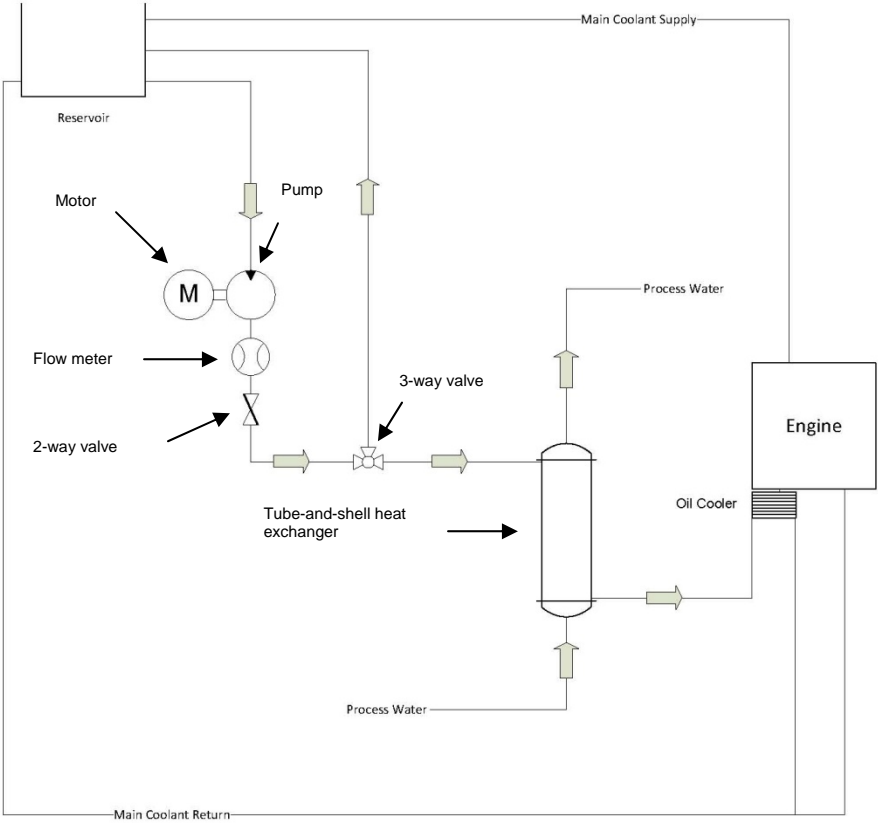

Fig.A15.1 Typical Engine Oil Cooling System Schematic