

**Sequence IIIF Engine Oil Certification Test  
Engine Assembly Manual**

**Contact Person  
Bruce Matthews  
GM Powertrain Materials Engineering  
823 Joslyn Road  
Pontiac, MI. 48340-2920  
Phone 248-830-9197**

**Revision '35  
"....."Qevqdt '32, 4036**

## Table of Contents

Hardware usage guidelines .....	Section 0
Revision Timeline.....	Section 01
Cleaning and Pre Hone Preparation.....	Section 1
Cylinder Block Honing.....	Section 2
Short Block Assembly .....	Section 3
Front Cover, Rear cover, and Sump.....	Section 4
Cylinder Head and Valves .....	Section 5
Cylinder Head and Valves, Hardened Seat Inserts, PN 24502260S.....	Section 5a
Long Block Assembly.....	Section 6
Final Dress .....	Section 7
OH Technologies Special Engine Dress .....	Section 8

## **Section 0**

### **Hardware usage guidelines**

All materials used in this test must conform to acceptance guidelines as specified in the ASTM Sequence IIIF Test Procedure accompanied by the direction and information contained in this Assembly Manual.

Any changes in procedures or substitutions of qualified parts or materials, must be approved by the Sequence IIIF / G Surveillance Panel prior to their use in non-reference and reference oil tests.

Any parts or materials specified in this document that are found to be unacceptable for testing, both pre and post test, must be reported to the Test Sponsor, the appropriate Critical Parts Distributor, and the ASTM Test Monitoring Center.

Unless otherwise directed, all parts and materials required for testing should be stored and used on a first in – first out basis following the guidelines outlined in the ASTM Test Monitoring Center Sequence IID and IIIE Information Letter #60 June 21, 1991.

## **Section 01**

### **Revision Update Timeline**

Sequence IIIF Engine Assembly Manual Update Revision Timeline

Latest Revision 1H

Date ~~FEB~~ 2014

Contact Person Rich Grundza TMC 412-365-1031

Bruce Matthews GM Pontiac 248-830-9197

Date	Sec.	Sheet	Topic	Comments	Info Letter
10/12/98	3	3	Short Block Assembly	Update 2nd design block & part numbers	
11/6/99	1	2	New Block and Pre-Hone Prep	Dip stick reamer, cam tunnel prep	
11/6/99	1	3	New Block and Pre-Hone Prep	Update drawing, indicated fastener locations	
11/6/99	1	5	New Block and Pre-Hone Prep	Update drawing	
11/6/99	1	7	New Block and Pre-Hone Prep	Add head gasket part numbers	
11/6/99	3	5	Short Block Assembly	Update crankshaft cleaning (Mylar Tape Polishing)	
11/6/99	4	1	Front Cover, Rear Cover & Sump	Update view, add adapter	
11/7/99	3	3	Short Block Assembly	Update part numbers and add note 3 (cam tunnel deburring)	
11/7/99	3	4	Short Block Assembly	Update oil gallery cleaning	
11/7/99	3	9	Short Block Assembly	Update part number (engine bearing)	
11/7/99	3	13	Short Block Assembly	Update view "A"	
11/7/99	3	14	Short Block Assembly	Update view "A, B, Z"	
11/13/99	3	8	Short Block Assembly	Update ring gap dimensions	
11/13/99	3	11	Short Block Assembly	Add De-burring operation	
11/13/99	5	1	Head Assembly	Update part number (valve spring)	
11/13/99	6	1	Long Block Assembly	Update lifter part number and installation instructions	
11/13/99	6	4	Long Block Assembly	Remove SPO part number for rocker arm bolts	
11/13/99	6	9	Long Block Assembly	Update part number and modification information	
11/13/99	6	11	Long Block Assembly	Update part number and view	
11/30/99	6	7	Long Block Assembly	Add exploded view	
12/1/99	2	7	Cylinder Honing	Change note from 0.0005" to 0.005"	
12/1/99	4	4	Front Cover, Rear Cover & Sump	Add sealer usage	
12/1/99	4	6	Front Cover, Rear Cover & Sump	Add sealer usage	
12/1/99	4	7	Front Cover, Rear Cover & Sump	Add thermocouple information	
12/1/99	4	10	Front Cover, Rear Cover & Sump	Add sealer usage	
12/1/99	4	12	Front Cover, Rear Cover & Sump	Add sealer usage	
12/1/99	5	1	Head Assembly	Update valve spring calibration	
12/1/99	6	4	Long Block Assembly	Add note on engine rotation	
12/1/99	6	6	Long Block Assembly	Update part number (RTV sealer)	
6/20/00	3	8	Short Block Assembly	Update ring gap dimensions	

Sequence IIIF Engine Assembly Manual Update Revision Timeline

Latest Revision 1H

Date ~~FEB~~ 2014

Contact Person Rich Grundza TMC 412-365-1031

Bruce Matthews GM Pontiac 248-830-9197

Date	Sec.	Sheet	Topic	Comments	Info Letter
6/22/00	3	3	Short Block Assembly	Update part number (cam bearings)	
6/22/00	3	11	Short Block Assembly	Update part number (0.153" thrust plate)	
6/22/00	4	13	Front Cover, Rear Cover & Sump	Add new oil pan part number	
6/22/00	6	1	Long Block Assembly	Add ACI test lifter	
6/22/00	6	7	Long Block Assembly	Update coolant return line description	
9/5/00	1	5A	New Block and Pre-Hone Prep	Jet Washer parts cleaning procedure	
9/5/00	3	5	Short Block Assembly	Update crankshaft cleaning (Mylar Tape Polishing)	
9/5/00	6	11A	Long Block Assembly	Update to include Cast and PM torque values	
9/7/00	3	4	Short Block Assembly	Update part numbers (engine bearings)	
9/7/00	3	6	Short Block Assembly	Update part numbers (engine bearings)	
9/7/00	3	8	Short Block Assembly	Update ring gap instructions and part numbers	
10/18/00	3	11	Short Block Assembly	Update operation (thrust face de-burring)	
10/18/00	4	2	Front Cover, Rear Cover & Sump	Update oil pump gear clearance	
2/22/01	6	11	Long Block Assembly	Update description, "Procedure Reference"	
2/1/02	1	4	New Block and Pre-Hone Prep	Update text class 2B Tap & reamer	
2/1/02	1	6	New Block and Pre-Hone Prep	Update text "add line C" "Main cap side bolts"	
2/1/02	1	5A	New Block and Pre-Hone Prep	Add PDN 50 soap	
2/1/02	3	6	Short Block Assembly	Update description, "Add C, change Z to Y3"	
2/1/02	3	8	Short Block Assembly	Add Starrett Taper Gage	
2/1/02	3	11	Short Block Assembly	Add note item # 2, 0.152" thrust plate and camshaft part #	
2/1/02	3	14	Short Block Assembly	Update torque and replace each test, camshaft bolt	
2/4/02	1	1	New Block and Pre-Hone Prep	Check main bore and cam tunnel alignment	
2/14/02	4	2	Front Cover, Rear Cover & Sump	Add clearance specification	
2/14/02	4	4	Front Cover, Rear Cover & Sump	Add clearance specification	
2/14/02	4	12	Front Cover, Rear Cover & Sump	Add clearance check	
2/22/02	5	1	Head Assembly	Update valve spring calibration	
2/22/02	6	1	Long Block Assembly	Update test lifter part number	
2/22/02	6	6	Long Block Assembly	Delete first design intake gasket	
2/22/02	6	7	Long Block Assembly	Add Perfect Seal #4	
2/22/02	6	9	Long Block Assembly	Update throttle body part numbers	

Sequence IIIF Engine Assembly Manual Update Revision Timeline

Latest Revision 1H

Date FEB/2014

Contact Person Rich Grundza TMC 412-365-1031

Bruce Matthews GM Pontiac 248-830-9197

Date	Sec.	Sheet	Topic	Comments	Info Letter
2/22/02	6	11A	Long Block Assembly	Delete sheet	
2/22/02	7	6	Final Dress	Update throttle body part numbers	
2/22/02	8	1	OHT	Update view "Add exhaust sample/pressure"	
2/22/02	8	2	OHT	Add warning on RTV Sealer	
2/22/02	8	4	OHT	Change view "inlet air temperature sensor"	
6/17/02	1	2	New Block and Pre-Hone Prep	Add Rotary Tool Information	
6/17/02	1	3	New Block and Pre-Hone Prep	Change sealer to Perfect Seal #4	
6/17/02	3	5	Short Block Assembly	Update "A" polishing of crankshaft	
6/17/02	3	13	Short Block Assembly	Add inspection of balance shaft gear	
6/17/02	4	2	Front Cover, Rear Cover & Sump	Add inspection of oil gear housing in front cover	
6/17/02	4	4	Front Cover, Rear Cover & Sump	Update view, add info on by-pass valve with reference	
6/17/02	6	7	Long Block Assembly	Change to Permatex #2	
6/17/02	6	8	Long Block Assembly	Add "Max. torque"	
6/17/02	6	9	Long Block Assembly	Change part number 2 bolt Mass Air Flow Sensor	
6/17/02	8	3	OHT	Update view & part numbers	
6/17/02	8	3a	OHT	Add sheet	
6/18/02	6	2	Long Block Assembly	Add oiling of pushrod ball ends	
6/18/02	9	3b	OHT	Add Sheet	
4/28/03	1	5A	Cleaning instructions	Removal of NAT50/PDN50 soap residue	
4/28/03	3	8	Ring Color Code	Addition of color code identification	
4/28/03	4	1	Front Cover usage	Change OHT epoxy impregnated front cover part #	
4/28/03	4	12	Pan Gasket	Change to 2003 gasket part #	
4/28/03	6	9	MAF part #	Add new mass airflow sensor part #	
6/23/03	6	9	MAF part #	Add remanufactured part #88961007	
6/23/03	7	6	MAF part #	Add remanufactured part #88961007	
12/15/03	1	1	Block part #	Change block part # from drawing # to 24502286	IIIG-03-3
12/15/03	1	5	Solvent specification	Update to mineral spirit	
12/15/03	1	5A	Solvent specification	Update to mineral spirit	

Sequence IIIF Engine Assembly Manual Update Revision Timeline

Latest Revision 1H

Date ~~4/4/2014~~ ~~4/4/2014~~ 2014

Contact Person Rich Grundza TMC 412-365-1031

Bruce Matthews GM Pontiac 248-830-9197

Date	Sec.	Sheet	Topic	Comments	Info Letter
12/15/03	1	6	Fastener	Updated fastener usage	
12/15/03	2	7	Honer	Update ratchet feed setting	
12/15/03	2	8	Honer	Update honing procedure	
12/15/03	2	9	Honer	Update revised loads and target sizing	
12/15/03	2	10	Honer	New page, honer calibration requirements	
12/15/03	2	11	Honer	New page, honer maintenance requirements	
12/15/03	2	12	Honer	New page, honer maintenance requirements	
12/15/03	3	5	Solvent specification	Update to mineral spirit	
12/15/03	3	6	Fastener	Update fastener usage	
12/15/03	3	8	Rings	Update paint removal and solvent usage	
12/15/03	3	11	Camshaft	Update solvent usage and lubrication requirements	
12/15/03	4	5	Sealer	Update approved sealer specification	
12/15/03	4	12	Sealer	Update approved sealer specification	
12/15/03	5	1	Solvent specification	Update to mineral spirit	
12/15/03	6	1	Solvent specification	Update to mineral spirit	
12/15/03	6	2	Solvent specification	Update to mineral spirit	
12/15/03	6	6	Sealer	Update approved sealer specification	
12/15/03	6	11	Text	Update text block (injector flow testing) reference procedure	
12/15/03	7	4	Part #	Add new sheild 24508586	
3/15/04	4	12	Silicone Sealer	Update Sealer part numbers	IIIG-04-1
3/15/04	6	6	Sealer & Gasket	Update sealer and intake gasket part numbers	
11/3/04	3	7	Con Rod part numbers	Update to include Cast and PM numbers	IIIG-04-3
11/3/04	3	9	Con Rod Torques	Update to include Cast and PM torque values	
11/3/04	4	1	Front Oil Seal	Update to new OHT part number	
11/3/04	4	4	Front Oil Seal	Update to new OHT part number	
11/3/04	4	9	Rear Oil Seal	Update to new OHT part number	
11/3/04	4	12	Oil Pan Gasket	Update to new OHT part number	
11/3/04	5	1	Exhaust Valve	Update to new SPO part number	



Sequence IIIF Engine Assembly Manual Update Revision Timeline

Latest Revision 1H

Date ~~6/6/2014~~ 6/6/2014

Contact Person Rich Grundza TMC 412-365-1031

Bruce Matthews GM Pontiac 248-830-9197

Date	Sec.	Sheet	Topic	Comments	Info Letter
The following updates cover information letters IIIG-05 through IIIG-06-					
6/22/06	All Sections		Global text change from Mineral Spirits to Degreasing Solvent		
6/22/06	1	1	Bore alignment check	Change alignment check to optional	
6/22/06	1	6	Fastener installation	Remove plastic mallet from usage text	
6/22/06	1	7	Torque Wrench	Add ETW-E-180 torque wrench information	
6/22/06	2	8	Honing	Update according to S.P.direction 6/6/06	
6/22/06	3	2	Data recording	Add data recording Annex A.14	
6/22/06	3	5	Update	Update text and part numbers	
6/22/06	3	6	Update	Update view, fastener prep, and clearance spec.	
6/22/06	3	7	Piston & Rod	Update cleaning and rod orientation information	
6/22/06	3	8	Update and expand	Expand sheet and add additional sheet (8A)	
6/22/06	3	9	Cast Rods	Remove cast rod information	
6/22/06	3	11	Fastener usage	Update fastener usage and inspection information	
6/22/06	3	12	Part number update	Update balancer shaft part number	
6/22/06	4	2	Front Cover	Add usage information	
6/22/06	4	4	Oil filter adapter	Update sealer usage information	
6/30/06	4	7	Front Cover Assembly	Update view and part numbers	
6/30/06	4	8	Front Cover	Update fastener information	
7/20/06	4	9	Rear Cover	Update part numbers for rear cover and crankshaft seal	
7/20/06	4	10	Rear Cover	Update fastener usage	
2/1/06	4	11	Part number update	Updated gasket part number	
2/5/06	4	13	Part number update	Updated fastener part number information	
6/30/06	5	1	Valve & Springs	Update cleaning procedure and valve part number	
7/20/06	5	3	Cyl. Head fastener	Update part number information	
7/20/06	6	1	Lifter installation	Update cleaning info and installation information	
7/20/06	6	2	Pushrod installation	Update cleaning info and degreasing solvent	
7/20/06	6	3	Rocker retainer	Update usage information	
7/20/06	6	6	Update	Update upper intake gasket part number change	

Sequence IIIF Engine Assembly Manual Update Revision Timeline

Latest Revision 1H

Date ~~4/4/2014~~ ~~4/4/2014~~

Contact Person Rich Grundza TMC 412-365-1031

Bruce Matthews GM Pontiac 248-830-9197

Date	Sec.	Sheet	Topic	Comments	Info Letter
The following updates cover changes through April 1, 2007					
3/30/07	1	7	Cylinder Head Fastener Torque	Fastener torque procedure for honing deak plates	
3/30/07	3	9	Rod Bolt Torque	Connecting rod torque + anglew update for PM rods	
3/30/07	3	11	Pre-test Camshaft Lubrication	Update procedure for EF-411 vs test oil lubricating process	
3/30/07	4	6	Front Cover Gasket	Update gasket part number changes	
3/30/07	5	3	Cylinder Head Fastener Torque	Fastener head torque procedure for cylinder head installation	
3/30/07	6	5	Rocker Cover	Update rocker cover part number change	
3/30/07	6	8	Upper Intake Gasket	Update upper intake gasket part number change	
The following updates cover changes through March 5, 2010					
2/22/10	1	5A	Block Cleaning	Changed washer temp to metric value and added tolerance	
2/22/10	1	7	Stress Plates	Updated head gasket and bolt p/n, added source for bolts	
2/22/10	2	10	Honing Machine	Changed wording from calibrated to verified	
2/22/10	3	6	Thread Lubrication	Deleted note prohibiting thread lubrication	
2/22/10	3	8	Ring Gap Measurement	Deleted OHT3F gages, added measurement in block	
2/22/10	4	9	Seal Installation	Added Kentmore J38196 tool for rear seal installation	
2/22/10	4	10	Rear Seal Housing	Allowed bolts to be used as long as the remain serviceable	
2/22/10	5	3	Head Assembly	Corrected short bolt p/n	
2/22/10	4	10	Upper Intake	Deleted sud 24502453 and increased to 2 bolt 24505205	
The following updates cover changes through April 10, 2012					
4/10/12	1	5A	Block Cleaning	Revised cleaning solution change frequency to no more than 25 hours of use	
4/10/12	3	8	Piston Bore Sizing	Corrected targeted bore value for 12/2 pistons and updated piston ring part numbers	

Sequence IIIF Engine Assembly Manual Update Revision Timeline

Latest Revision 13

Date 10/10/2014

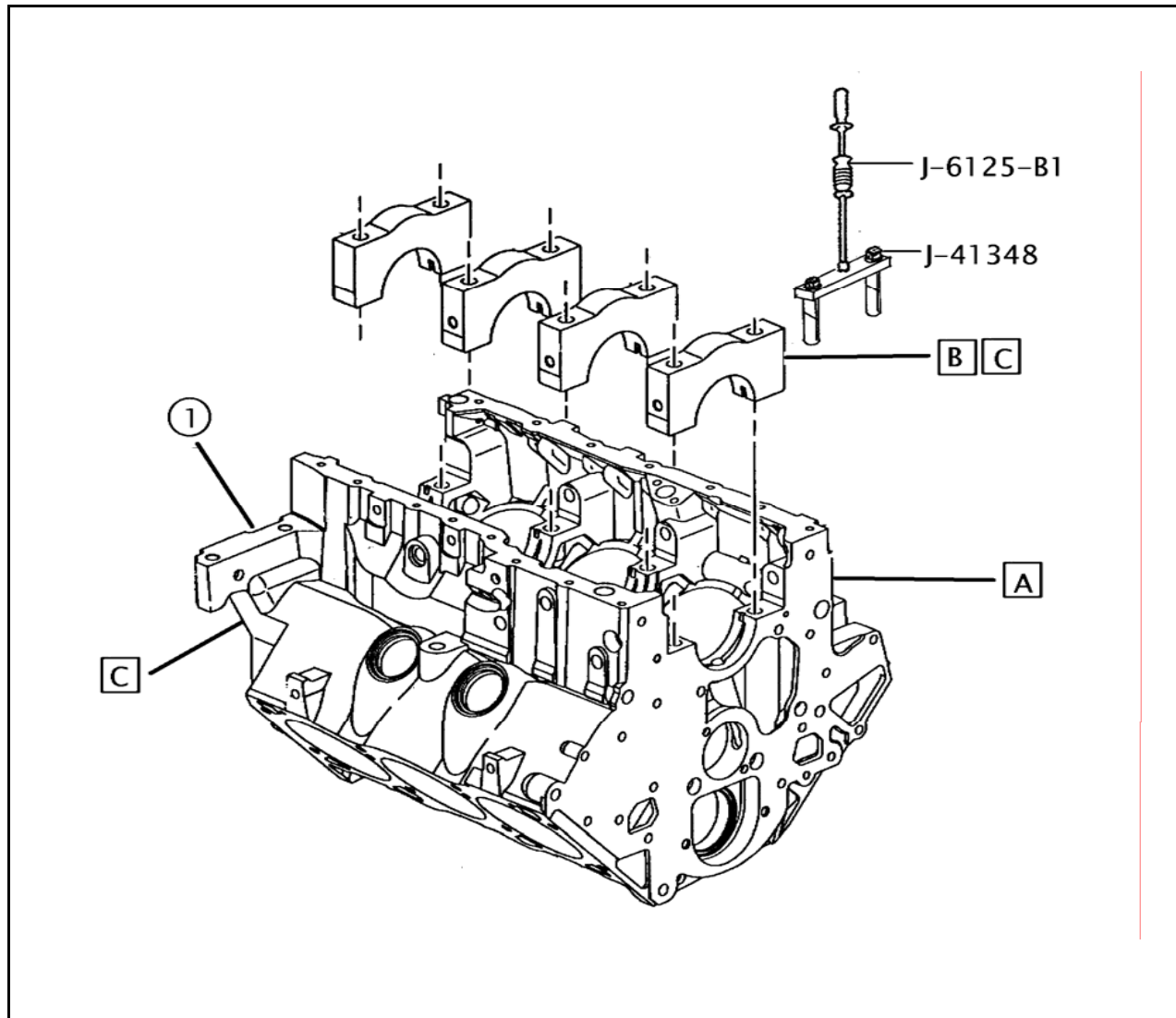
Contact Person Rich Grundza TMC 412-365-1031

Bruce Matthews GM Pontiac 248-830-9197

Date	Sec.	Sheet	Topic	Comments	Info Letter
The following updates cover changes through May 02, 2013					
4/2/13	4	2	Front, Rear Cover and Sump	Increased the drop in clearance to 0.153 mm	
The following updates cover changes through March 25, 2014					
3/24/14	5a	1	Initial Measurements 24502260S head	Added Section to address initial measurement of heads	14-1
3/24/14	5a	2	Preparations for Reuse	Added Section to address preparations to reuse head	
3/24/14	5a	3	Additional Measurements	Added Section to address additional measurements	
3/24/14	5a	4	Final preparations	Added section for completion of steps to reuse head	
3/24/14	5a	5	Valve and Spring Assembly	Added section for valve and spring install in reused head	
3/24/14	5a	6	Gasket Install	Added section for installing head gaskets with reused head	
3/24/14	5a	7	Cylinder head installation	Added section for installation on engine of reused head	
The following updates cover changes through October 10, 2014					
10/10/14	2	10	Honing	Removed requirement for verification to be performed by qualified sunnen technician	

## **Section 1**

### **Cleaning and Pre Hone Preparation**



Description of Operation	
A	Upon introduction of a new block into the system, check for any damage to machined surfaces which might have occurred during shipping or handling.  Optional: Check crankshaft main bore alignment using appropriate mandrel.
B	Remove main cap side & main bolts. Use Kent-Moore J-41348 main bearing cap puller (12Nm) & J-6125-1B slide hammer to remove main caps. <b>Note: Main bearing caps are press fit. Do not hammer caps back and forth during removal. Damage to the caps may result in damage to engine bearings during test.</b>
C	Record engine serial number and or assign a laboratory number and mark necessary identification on engine block and crankshaft main caps. <b>Note: Do not use stamped tool set for marking identification on main caps.</b>

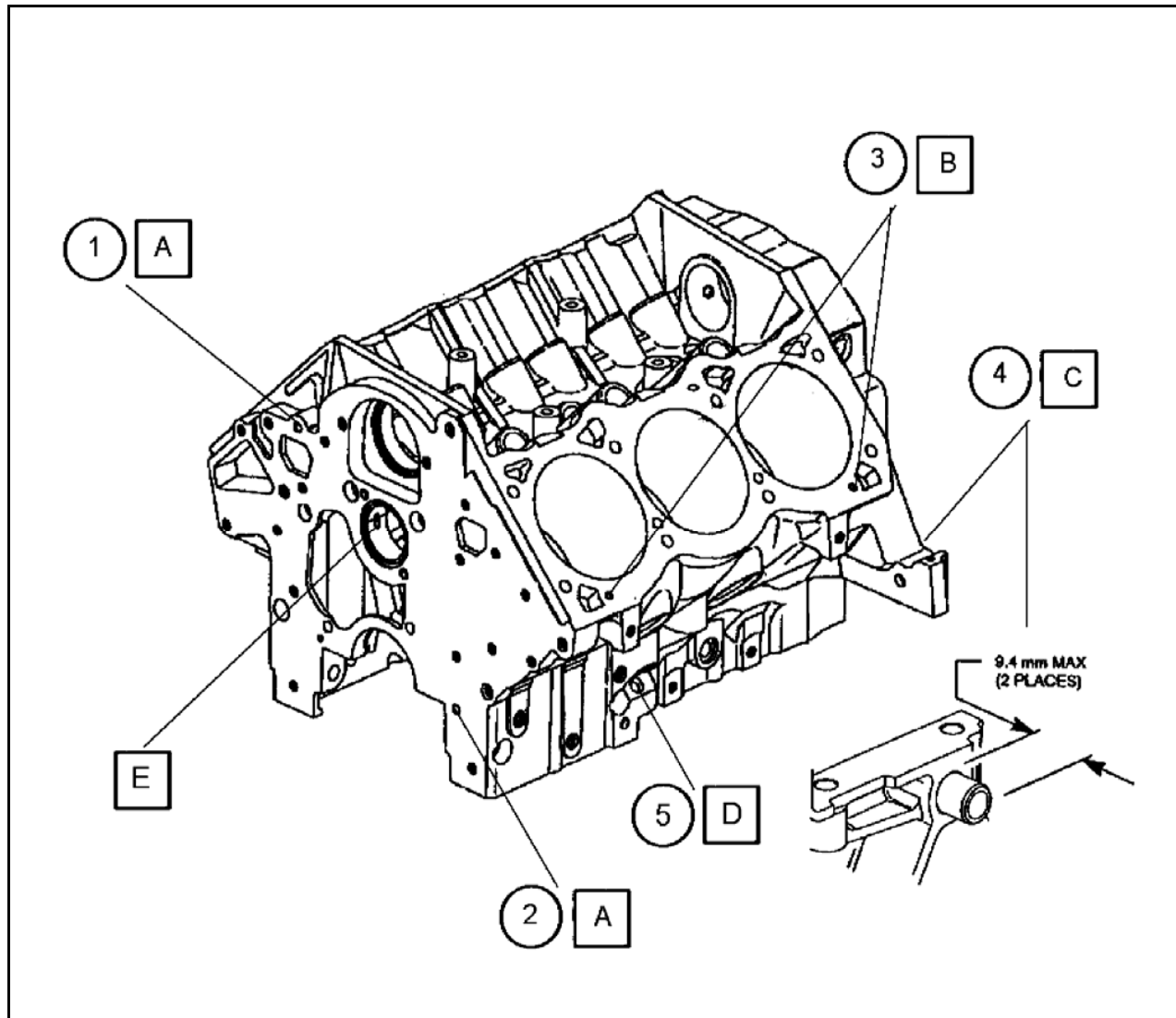
Specification	
1	24502286 Block Assembly

REV	Date	Revision History
1	12/31/97	Block-1
2	12/15/03	Change from engineering drawing part # (24506028) to actual part # 24502286
3	06/22/06	Change main bore alignment check to optional

View	
<b>Engine Block</b>	
New block and pre-hone prep	
Serial Number Locations	

<b>New Block and Pre-Hone Prep</b>	<b>Sequence III F</b>
------------------------------------	-----------------------

Section	Sheet
1	1



Description of Operation	
A	Install locating pins on front face.
B	Install locating pins on cylinder deck
C	Install locating pins on rear transmission mount face.
D	Use OHT3F-071-1 reamer to size dip stick hole for calibrated dip stick
E	Deburr all leading edges of camshaft tunnel bores and oil gallery cross drilled intersections through tunnel bores using emery cloth, rotary tool with carbide cutters, stones, or wire wheels as necessary to remove sharp edges.

Specification	
1	24501162 Pin Front Cover Upper
2	25536323 Pin Front Cover Lower
3	25536320 Pin Cyl. Head Location
4	12338076 Pin Trans. Location
5	OHT3F-071-1 Reamer

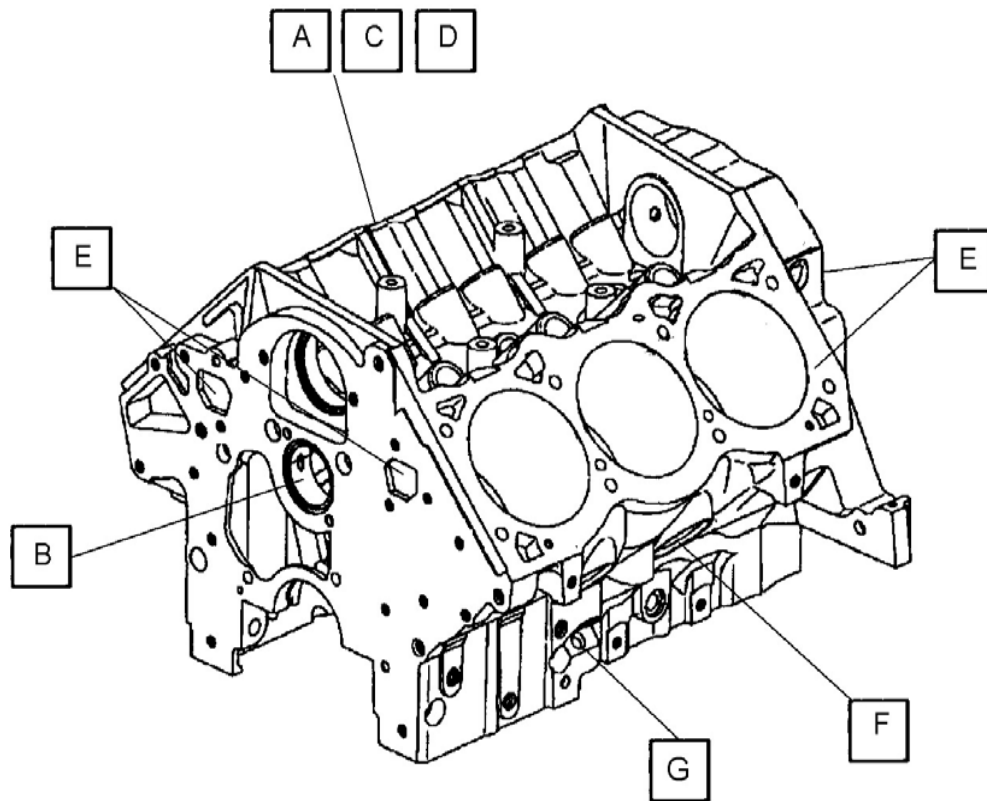
REV	Date	Revision History
1	12/31/97	Block-2

View	
Engine Block	
New block and pre-hone prep	
Locating pin installation	
Camshaft tunnel and dip stick prep	

<b>New Block and Pre-Hone Prep</b>	<b>Sequence III F</b>
------------------------------------	-----------------------

Section	Sheet
1	2

			<b>Description of Operation</b>	
			<p>A Install threaded fasteners with #2 Non-Hardening Permatex or Perfect Seal #4 in locations identified in view.</p> <p>B Install 1/4NPT plug in main oil gallery on the right front side of engine block.</p> <p>Note: This location is not to be used for temperature control or thermocoupled.</p>	
			<b>Specification</b>	
			1 444777 Plug Auto Hex Socket	
<b>REV</b>	<b>Date</b>	<b>Revision History</b>	<b>View</b>	
1	12/31/97	Block-3	<b>Engine Block</b>	
			New block and pre-hone prep	
			Plugged holes in front of engine	
			<b>Section</b>	<b>Sheet</b>
<b>New Block and Pre-Hone Prep</b>			1	3
			<b>Sequence III F</b>	



**Description of Operation**

- A Remove all casting slag and core sand deposits from the coolant passages on new blocks and check for core sand deposits on used blocks
- B Remove all camshaft bearings and oil gallery plugs.
- C Clean all gasket surfaces.
- D Chase all threaded holes for the main caps and cylinder head fasteners using a Class 2B Tap.
- E Install block-off plates over the coolant passages on the front face, rear face, and cylinder deck. (Fabricate in-house)
- F Install coolant Welch plugs.
- G Ream dip stick hole using OHT3F-071-1 reamer for calibrated dip stick.

**Specification**

--

REV	Date	Revision History
1	12/31/97	Block-4

View
<b>Engine Block</b>
New block and pre-hone prep

<b>New Block and Pre-Hone Prep</b>	<b>Sequence IIIF</b>
------------------------------------	----------------------

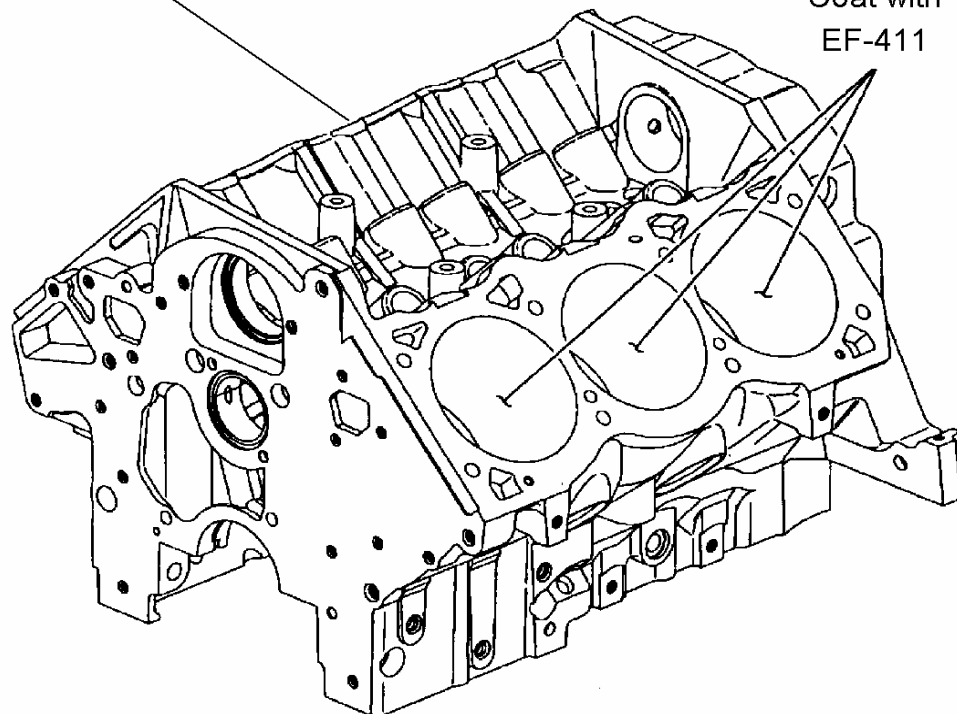
<b>Section</b>	<b>Sheet</b>
1	4



Spray engine with 50/50  
Solution EF-411 / Degreasing Solvent



Coat with  
EF-411



**Description of Operation**

- A The engine may be cleaned using an automated washing device, however, caution should be used to prevent oxidation flash over of the ferrous surfaces. Note: Do not use caustic chemicals or acid type baths. See 5A
- B The block must be thoroughly cleaned using brushes through the oil galleries, camshaft tunnel, and cylinder bores with degreasing solvent to remove any detergent residue before honing.
- ? (Step Sec. 1 sheet 6)  
Repeat step "A & B" above after honing.
- Note: If this is the final cleaning after honing, spray the entire engine block using a 50/50 solution of EF-411 and degreasing solvent. Air dry to remove excess solution.
- ? (Step Sec. 3 sheet 1)

**Specification**

--

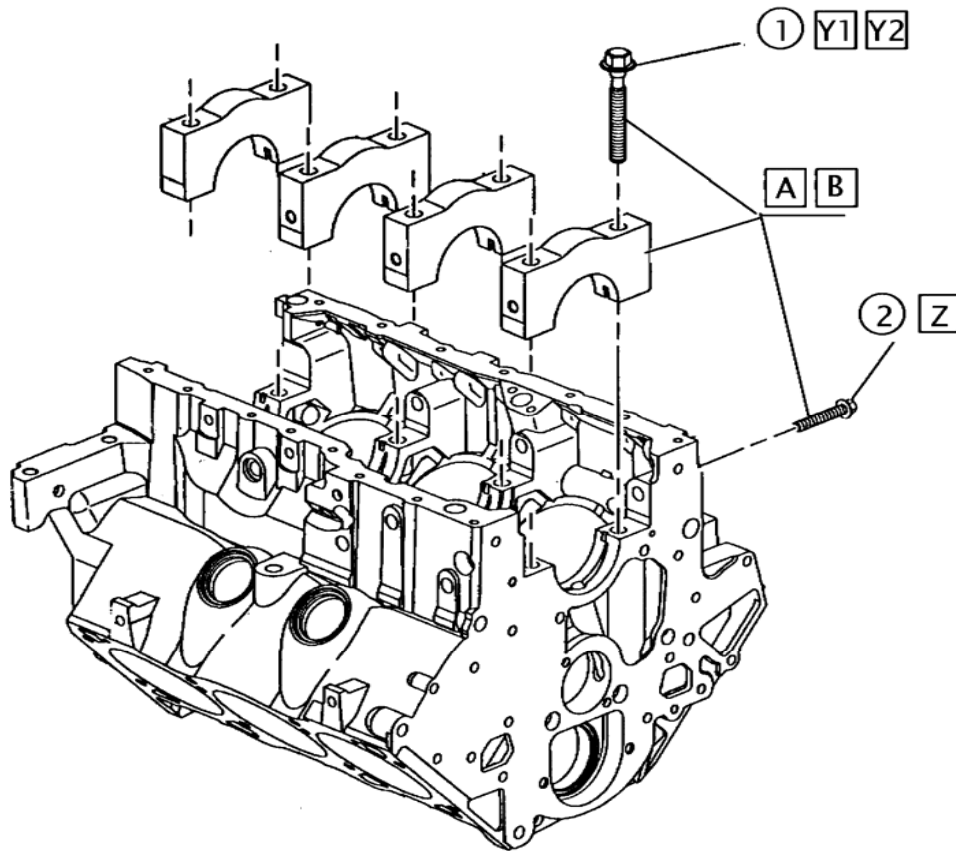
REV	Date	Revision History
1	12/31/97	Block-5
2	12/15/03	Update, change to mineral spirits
3	6/22/06	Update change to degreasing solvent

View
<b>Engine Block</b>
Engine block cleaning

<b>New Block and Pre-Hone Prep</b>	<b>Sequence III F</b>
------------------------------------	-----------------------

Section	Sheet
1	5

			Description of Operation	
<p>Automatic Parts Washer Procedure for IIIG Engine Blocks</p> <ol style="list-style-type: none"> <li>1) Use only NAT-50-S or PDN-50 soap at a concentration of 16 pounds of soap per 380 Liters of water. Change the cleaning solution after no more than 25 hours of use.</li> <li>2) Set the temperature of the water to 140 degrees F.</li> <li>3) Do not pre-condition the water that is being used in any way.</li> <li>4) Prior to installing the block in the parts washer, ensure that all coolant passages are blocked off to prevent cleaning solutions from entering the passages.</li> <li>5) Allow the block to run through the cleaning cycle for a period of 30 to 40 minutes.</li> <li>6) After the cycle(s) are complete, immediately remove the block from the washer and spray it down with degreasing solvent.</li> <li>7) Wipe cylinder bores out with a lint free towel.</li> <li>8) Spray engine block with a mixture of 50/50 EF-411 and degreasing solvent.</li> </ol>				
			<b>Specification</b>	
REV	Date	Revision History	View	
1	9/5/00	Procedure for Better Engineering Jet Washer usage	<b>Engine Block</b>	
2	12/15/03	Update change to mineral spirits	Engine block cleaning procedure for automated type jet washers	
3	6/22/06	Update text change to degreasing solvent		
4	4/10/12	Revised the cleaning solution replacement frequency to not exceed 25 hours		
<b>New Block and Pre-Hone Prep</b>		<b>Sequence IIIF</b>	<b>Section</b>	<b>Sheet</b>
			1	5A



**Description of Operation**

- A Clean and oil all main cap bolts (EF-411) and install main caps. Note: Do not use air tools to run main caps down.
- B Install main cap with fasteners as guides and draw into position with speed handle and socket in crisscross pattern.
- C Install main cap side bolts
- Y1 Tighten all main bolts to 70 Nm to fully seat main caps and then loosen the bolts 360° counterclockwise.
- Y2 Torque & Angle  
20Nm then 40Nm + 35°+35°+35° (repeat 40Nm + 35° 3 times from center out)(use used fasteners for honing)
- Z Torque & Angle 15Nm + 45°

**Specification**

- 1 24503056 Bolt (8) see note Y (Tighten before Z)
- 2 24505576 Bolt (6) see note Z (Tighten after Y)

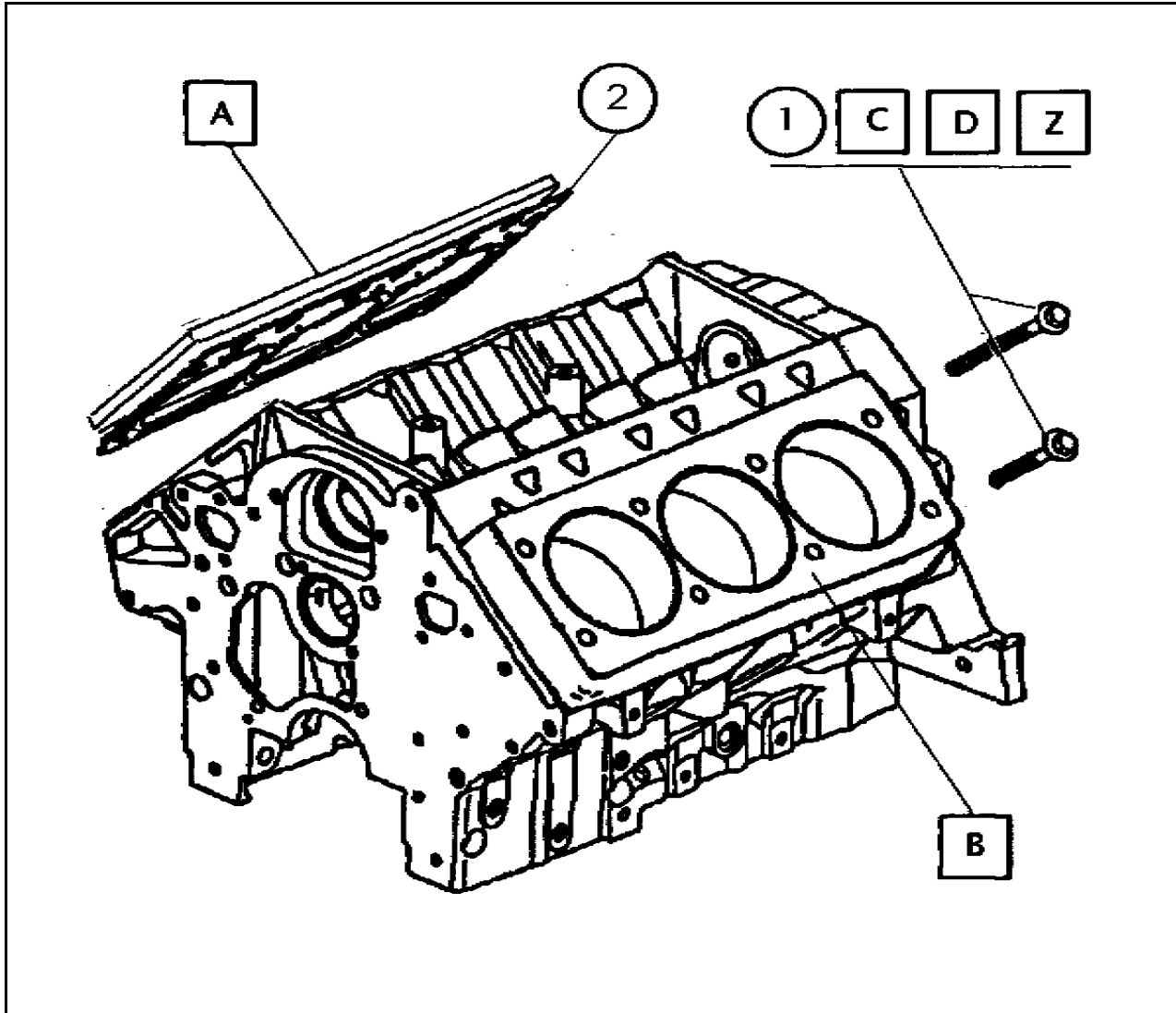
REV	Date	Revision History
1	1/10/98	Block-6
2	12/15/03	Clarification, add 40Nm + 35° 3 times... and (use used fasteners for honing) to Y2
3	6/22/06	Remove use of plastic mallet from "B"

View	
<b>Engine Block</b>	
Main cap installation	

**New Block and Pre-Hone Prep**

**Sequence IIIF**

Section	Sheet
1	6



Description of Operation	
A	Remove cylinder deck block off plates.
B	Install B-H-J Torque Plates w/gaskets (GM-3.8/3E-R-S-T-HT)
C	Note: When installing torque plates, 1) move the bottom row of fasteners to the top, 2) discard the top row of fasteners, 3) use the post test fasteners from the last teardown in the bottom row on the torque plates.
D	Torque fasteners from the center out using a crisscross pattern.  30Nm-50Nm-80Nm-123±9Nm
Z	(Step Sec.2 sheet 1)

Specification	
1	25527831K Bolt Cyl. Head (8)(Long) See note Z Use in upper and lower position with double hardened washers on lower row. Obtain washers from B-H-J. Obtain bolts from GM Racing
2	24503802 Gasket LH. 24503801 Gasket RH.

REV	Date	Revision History
1	1/1/98	Block-7
2	6/22/06	Update torque wrench information
3	3/30/07	Update fastener torquing procedure to 123Nm ± 9Nm final torque
4	3/5/10	Updated bolt number and source, corrected head gasket part numbers

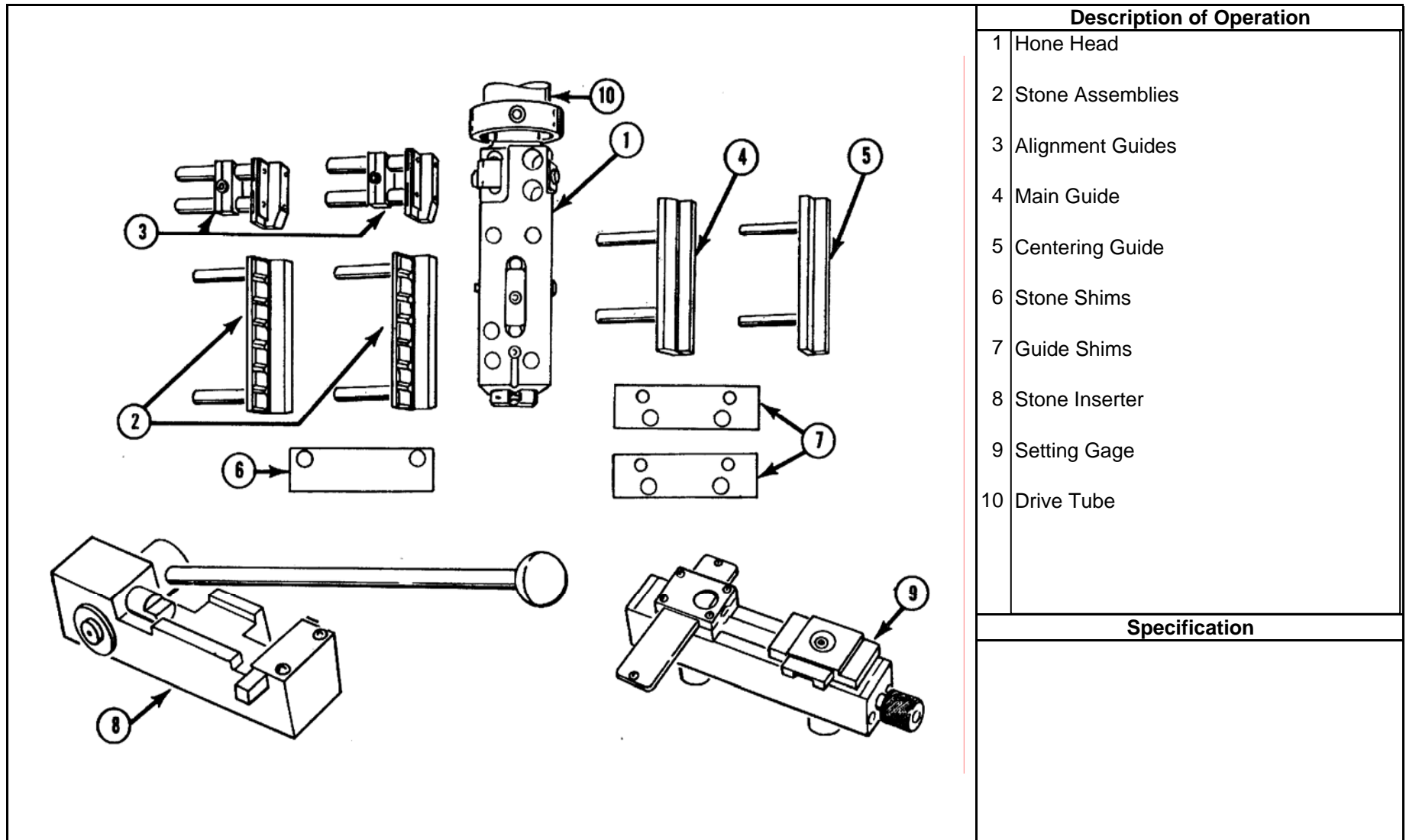
View	
Engine Block	
B-H-J Torque Plate installation	

New Block and Pre-Hone Prep	Sequence III F
-----------------------------	----------------

Section	Sheet
1	7

## **Section 2**

### **Cylinder Block Honing**



Description of Operation	
1	Hone Head
2	Stone Assemblies
3	Alignment Guides
4	Main Guide
5	Centering Guide
6	Stone Shims
7	Guide Shims
8	Stone Inserter
9	Setting Gage
10	Drive Tube

Specification	

REV	Date	Revision History
1	1/7/98	Hone-1-1

View	
Hone Unit Details	

**Cylinder Honing**

**Sequence IIIF**

Section	Sheet
2	1

**Description of Operation**

Set the turret block to the standard position and adjust the setting block snugly in the cylinder bore.

19 Place the stone assembly in the setting gage with the slide scale set at "0". Add shims as necessary to adjust to 1 - 2 on the slide scale for the stone and guide assemblies.

20 Place the plateau honing tool in the setting gage with the slide scale set at "0". Add shims as necessary to adjust to 3 - 4 on the slide scale.

Note: The alignment guides are not used during honing of IIIF blocks.

**Specification**

- 1 EHU 512 Stone
- 2 C30-PHT-731 Plateau Honing Tool

**View**

**Stones & Guides**

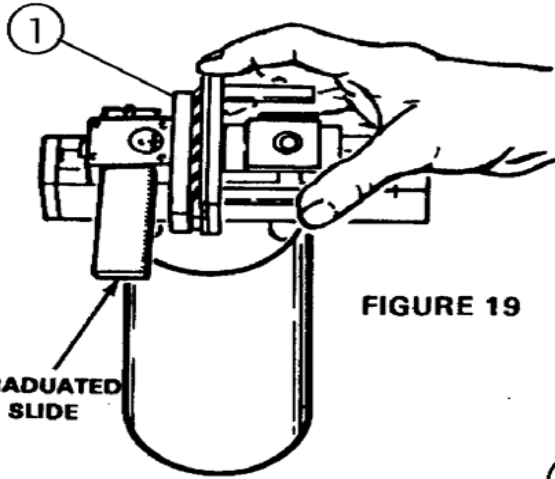
Stone and guide adjustment

**Section**

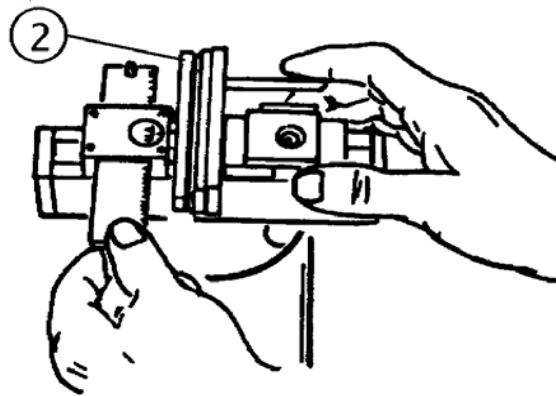
2

**Sheet**

2

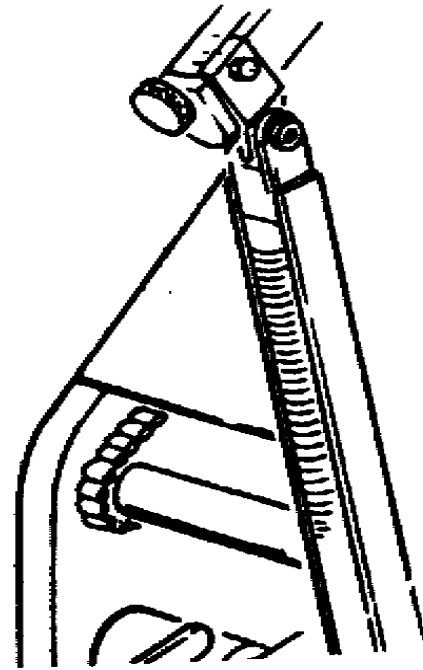
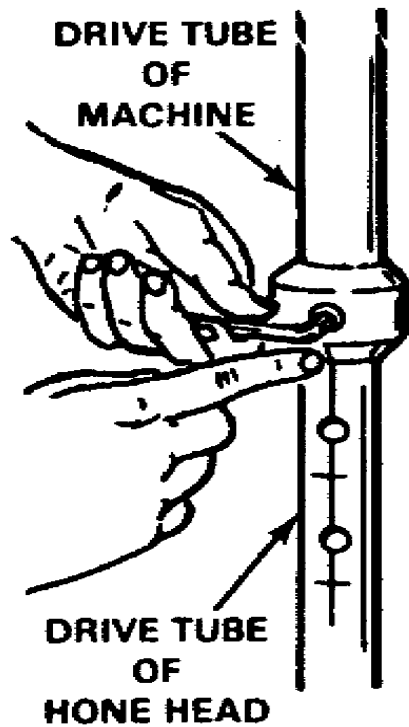


**FIGURE 19**



**FIGURE 20**

REV	Date	Revision History
1	1/7/98	Hone-3-1 & 3-2
<b>Cylinder Honing</b>		<b>Sequence IIIF</b>



**Description of Operation**

Slip the Drive Tube of the Hone Head into the Drive Tube of the CV-616-46 and tighten the set screw with the first set of index marks in line.

**Specification**

REV	Date	Revision History
1	1/7/98	Hone-2-2

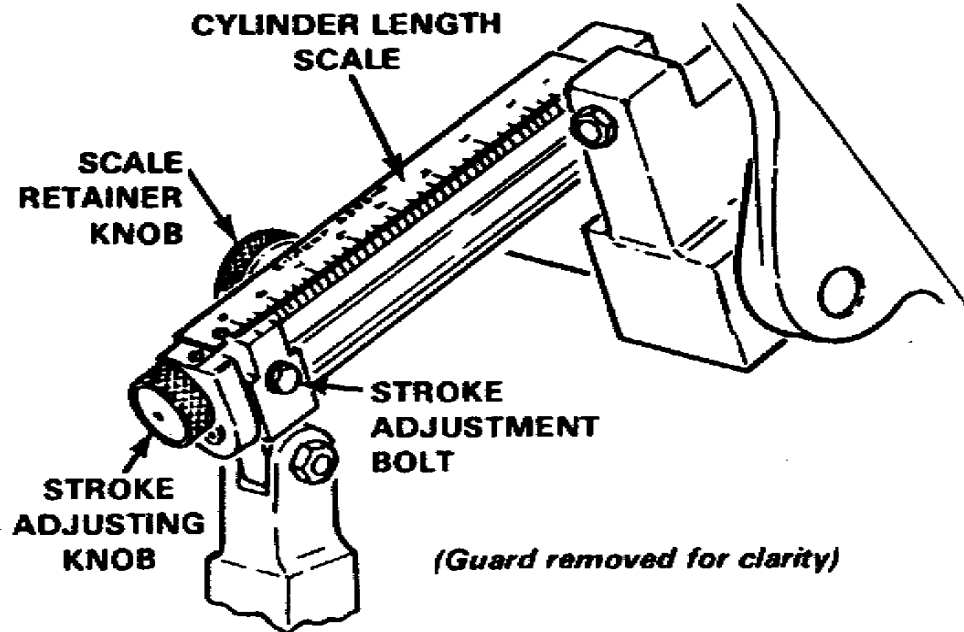
View
<b>Drive Tube</b>
Drive tube adjustment

**Cylinder Honing**

**Sequence III F**

Section	Sheet
2	3





**FIGURE 23**

**Description of Operation**

Loosen stroke adjustment bolt and set stroke length at 5 3/8"

Note; to change the Stroke Scale to Metric, order PNP 1275M.

**Specification**

**View**

**Stroke Length**

**Section**

2

**Sheet**

4

REV	Date	Revision History
1	1/7/98	Hone-4

**Cylinder Honing**

**Sequence III F**

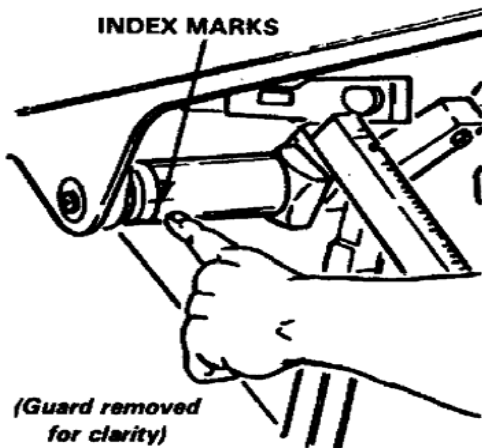


FIGURE 24

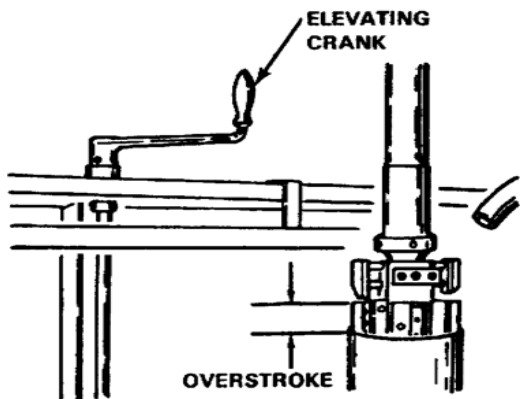


FIGURE 25

Stone Length		Top Overstroke Setting	
Inches	mm	Inches	mm
2-3/4"	70 mm	3/8"	9,5 mm
3-1/2"	89 mm	5/8"	16 mm
4-1/2"	115 mm	13/16"	21 mm
6"	152 mm	1-1/16"	27 mm

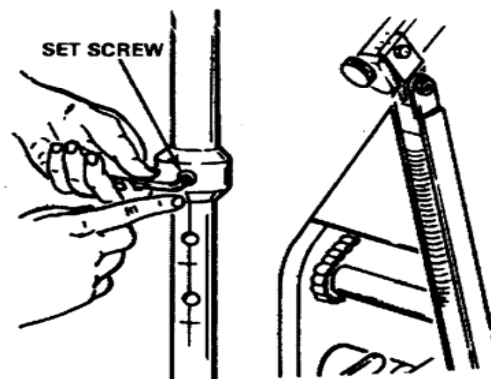


FIGURE 26

**Description of Operation**

With the hone head in the cylinder and the index marks lined up as shown in figure 24, use the elevating crank to adjust the overstroke length to 3/8" as indicated in figure 26 for 2 3/4" stone length.

Note: Drive tube should be set at first set of index marks.

**Specification**

**View**

**Overstroke**

Overstroke adjustment

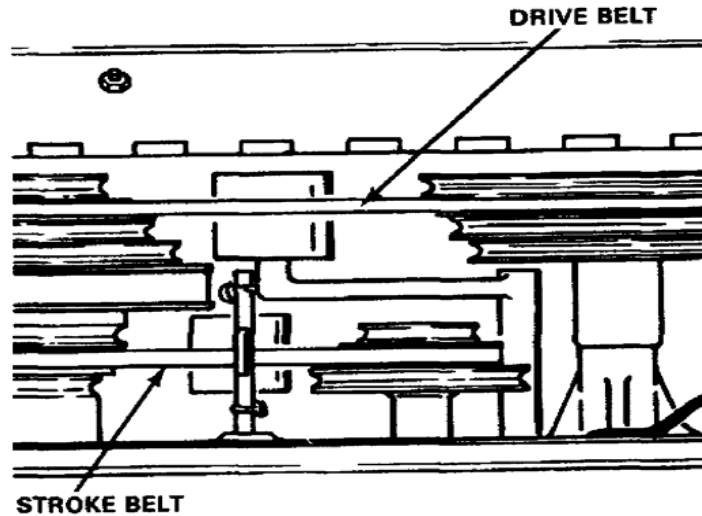
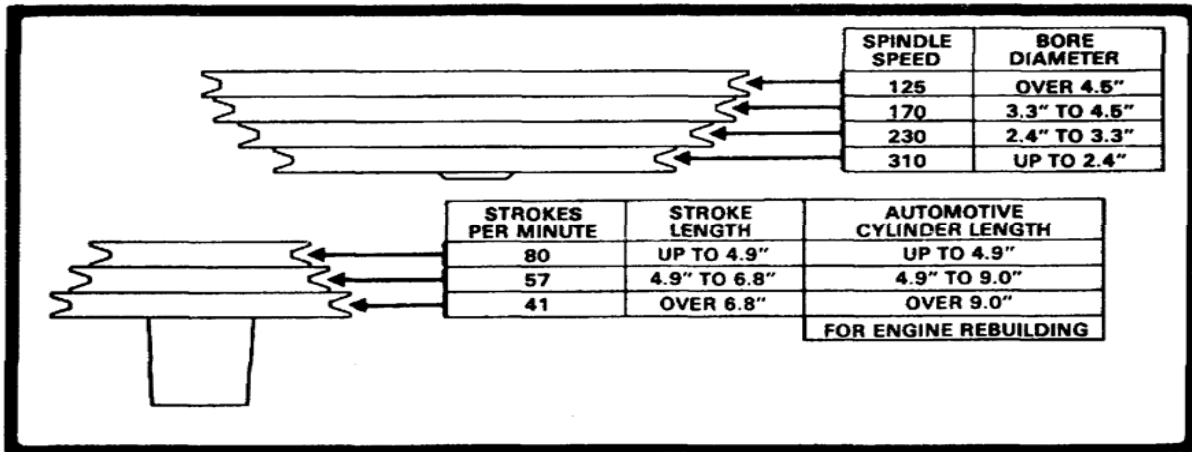
**Section**

2

**Sheet**

5

REV	Date	Revision History
1	1/7/98	Hone 4 & 5



**FIGURE 28**

**Description of Operation**

Open the left side of the belt cover and set the spindle speed at 170 and the strokes per minute at 57.

**Specification**

**View**

**Speed & Stroke**

**Section**

**Sheet**

2

6

REV	Date	Revision History
1	1/7/98	Hone-6

**Cylinder Honing**

**Sequence III F**

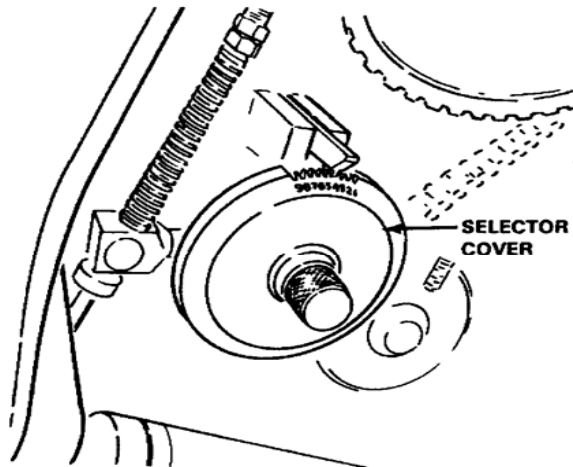


FIGURE 29

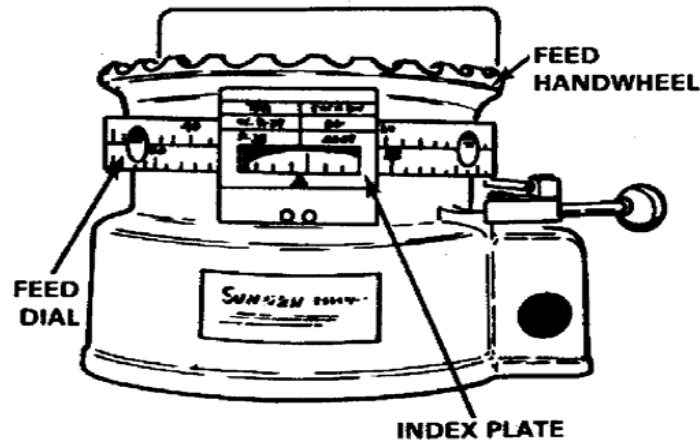


FIGURE 30

**Description of Operation**

Set the ratchet feed rate on the selector cover to 1 for the EHU 512 Stones. change the ratchet feed rate to 4 for the C30-PHT-731 Plateau Hone Brushes. See figure 29

Use the index plate for the lower scale identified as P28 .005 per division.

Note: to change the Hand Wheel Assembly and Stroke Plate to Metric, order CV-215MA.

**Specification**

REV	Date	Revision History
1	1/7/98	Hone-7
2	12/1/99	Change note from .0005 to .005
3	12/15/03	Update ratchet feed changes for stones and brushes

View	
Ratchet Feed & Index Plate	

**Cylinder Honing**

**Sequence IIIF**

Section	Sheet
2	7

### Honing Operations Guide

#### EHU-512 Stones (**Ratchet Feed Set to 1**) (**Block must be at room temperature before honing**)

- 1 Insert hone head into cylinder and rotate feed handle to the left while shaking the hone head until a slight resistance is felt.
- 2 Adjust the feed dial to a point where it will not shut off the honer over fifteen strokes
- 3 Set mode switch to timed mode and set controller to 15 seconds (15 seconds = 15 strokes)
- 4 Start the honer and adjust the load to 15 units, maintaining 15 units load by hand during honing. Apply no more than 15 strokes per cylinder at a time. (4 strokes minimum during final sizing) Switch stone positions in the hone head between each cylinder.  
Do not dwell machine when cylinder is within 0.01mm of target size.

- Note:1 Unit load will oscillate during normal operation. The intent is to hold 15 units as a minimum load during the honing process.
- Note:2 During final sizing, if less than 15 strokes are desired, set timer to desired seconds or operate in zero shut-off mode and never dwell machine or run less than 4 strokes / cylinder.

- 5 Follow recommended honing sequence (1,5,4,-3,2,6) do not hone adjacent cylinders
- 6 Size cylinders, 15 strokes / cylinder maximum, switching stone positions in hone head between each cylinder. Do not chase taper (dwell machine) when cylinder size is within 0.01mm of target. Stop honing with the EHU-512 stones when cylinder size is within 0.005mm of target size. Allow block to cool for fifteen minutes to confirm final size before brush honing.

#### C30-PHT-731 Plateau Honing Tool (**Ratchet Feed Set to 4**)

- 1 Insert hone head into cylinder and rotate feed handle to the left while shaking the hone head until a slight resistance is felt.
- 2 Adjust feed dial so it will not shut the machine off before the control panel timer.
- 3 Set mode switch to timed mode and set controller to 45 seconds.
- 4 Start honer and increase unit load to 20 units and allow to run until system shuts off.

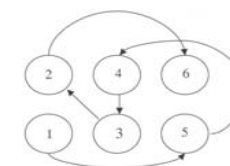
- Note:3 Proper ratchet feed setting is required to establish desired cylinder surface parameters using the C30-PHT-731 Plateau Hone Tool. After setting the initial load, the ratchet feed system will increase the load during the remaining time. Operators should not release load during this operation.

### Description of Operation

Use LP8X-55 Chlorine free fluid set at 7L/min. flow rate. Use dual canister filtration system with honing mats CV-1100. Change filters, fluid, and mats every 15 hours of operation.

See Section 2 Sheets 10 and 11 for honer calibration and maintenance requirements.

#### Honing Sequence



Note: When honing first run blocks, stroke limitations due not apply until cylinder size is within 0.0254mm (0.001in) of target size.

### Specification

### View

### Fluid and Operations Guide

### Section

2

### Sheet

8

REV	Date	Revision History
1	1/7/98	
2	12/15/03	Update honing information according to Surveillance Panel direction 12/15/03
3	6/22/06	Update honing information according to Surveillance Panel direction 6/6/06

**Cylinder Honing**

**Sequence III F**



**Honer Calibration**

All CV-616 hones must be verified on-site by a using the Hydraulic Pump and Reservoir Dynamometer. All CV-616 hones should be maintained according to the attached lubrication schedule each time the fluid and filters are changed.

Contact the Test Sponsor, ASTM Test Monitoring Center, Surveillance Panel Chairman, or Operations and Hardware Subpanel Leader for information on Sunnen calibration requirements.



**Description of Operation**

**Specification**

REV	Date	Revision History	View	
1	1/1/98	Hone-10	<b>Honer Calibration</b>	
2	12/15/03	Update honer calibration information		
3	2/22/10	Changed "All CV-616 honers must be calibrated" to "All CV-616 honers must be verified"		
4	7/1/11	Corrected typo		
5	10/10/14	Removed the requirement for verification to be performed by a sunnen technician		
<b>Cylinder Honing</b>		<b>Sequence III F</b>	<b>Section</b>	<b>Sheet</b>
			2	10

**Lubrication Point Table**

1	Connecting Rod Needle Bearings	#2 Grease	2 Pumps
2	Stroke Rocker Arm (two points)	#2 Grease	2 Pumps
3	Lower Drive Arm to Carriage Connecting Strap Bearing	#2 Grease	2 Pumps
4	Upper Drive Arm to Carriage Connecting Strap Bearing	#2 Grease	Remove plug from bolt and fitting. 2 pumps, and replace plug.
5	Upper Rod-feed Universal Joint	SAE 20 Oil	Coat Universal
6	One Way Roller on Solenoid Energizer Switch	SAE 20 Oil	1 Sqirt
7	Electrical Limit Shaft Bearings	SAE 20 Oil	1 Sqirt
8	Solenoid Plunger Bushing	SAE 20 Oil	1 Sqirt
9	Top of Connecting Rod where the Stroke Release Pawl rides	#2 Grease	Brush on area
10	Connecting Rod Shaft	#2 Grease	Coat
11	Stroke Release Pawl Pivots (two points)	SAE 20 Oil	1 Sqirt
12	Stroke Release Block	#2 Grease	1 Pump
13	Gear Reducer	Gear Oil 140	Drain and refill
14	Carriage Traverse Shaft (both ends)	#2 Grease	2 Pumps each
15	Carriage Traverse Shaft (two points)	SAE 20 Oil	2 Sqirts
16	Handwheel Gears (not shown)	Lubriplate Low-Temp	Remove the handwheel and repack handwheel gears.
17	Feed Pawls	SAE 20 Oil	Fill Oiler
18	Idler Arm Shafts (three points)	#2 Grease	1 Pump each
19	Gear Reducer Pully Shaft	#2 Grease	1 Pump

**Description of Operation**

Use LP8X-55 Chlorine free fluid set at 7 L/min. flow rate. Use dual canister filtration system with honing mats CV-1100. Change filters, fluid, and mats every 15 hours of operation.

Perform recommended lubrication as outlined in lubrication table each time the fluid and filters are changed.

See Sheet 12 for lubrication guide.

**Specification**

**View**

**Honer Maintenance**

**Section**

**Sheet**

2

11

**Cylinder Honing**

**Sequence IIIF**

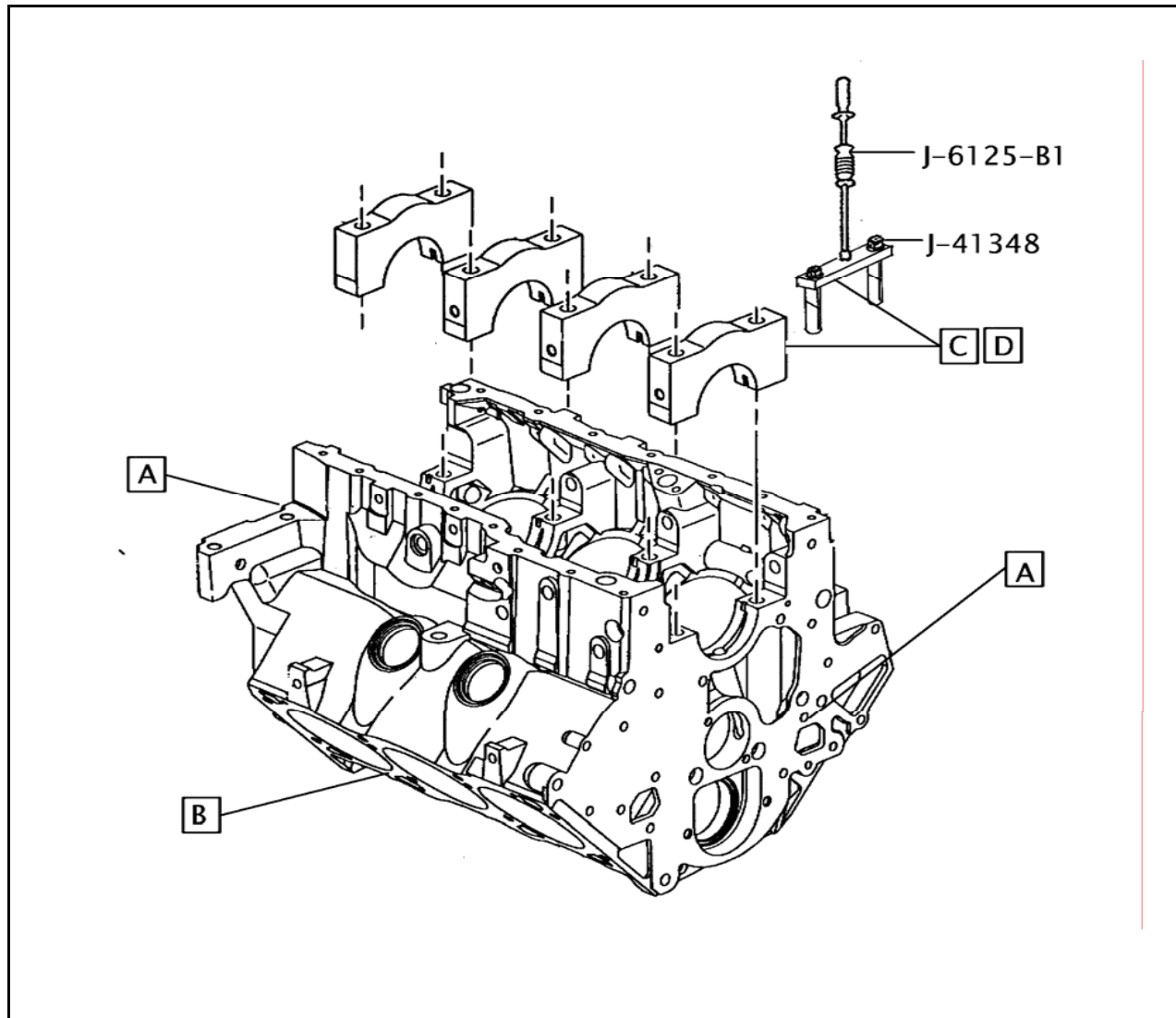
REV	Date	Revision History
1	12/15/03	New sheet, Honer maintenance



			Description of Operation	
<p>FIGURE 4-1, Lubrication</p>			Specification	
REV	Date	Revision History	Lubrication Guide	
1	12/15/03	New sheet, Lubrication points, visual guide		
Cylinder Honing		Sequence III F	Section	Sheet
			2	12

## **Section 3**

### **Short Block Assembly**



Description of Operation	
A	Remove all block off plates
B	Remove torque plates
C	Remove main cap side & main bolts.
D	Use Kent-Moore J-41348 main bearing cap puller & J-6125-1B slide hammer to remove main caps.
<p>Note: Main bearing caps are press fit. Do not hammer caps back and forth during removal. Damage to the caps may result in damage to engine bearings during test.</p>	

Specification

REV	Date	Revision History
1	01/01/98	Block-8

View	
Short Block	
Block off plate, torque plate and main cap removal	

Short Block Assembly	Sequence IIIF
----------------------	---------------

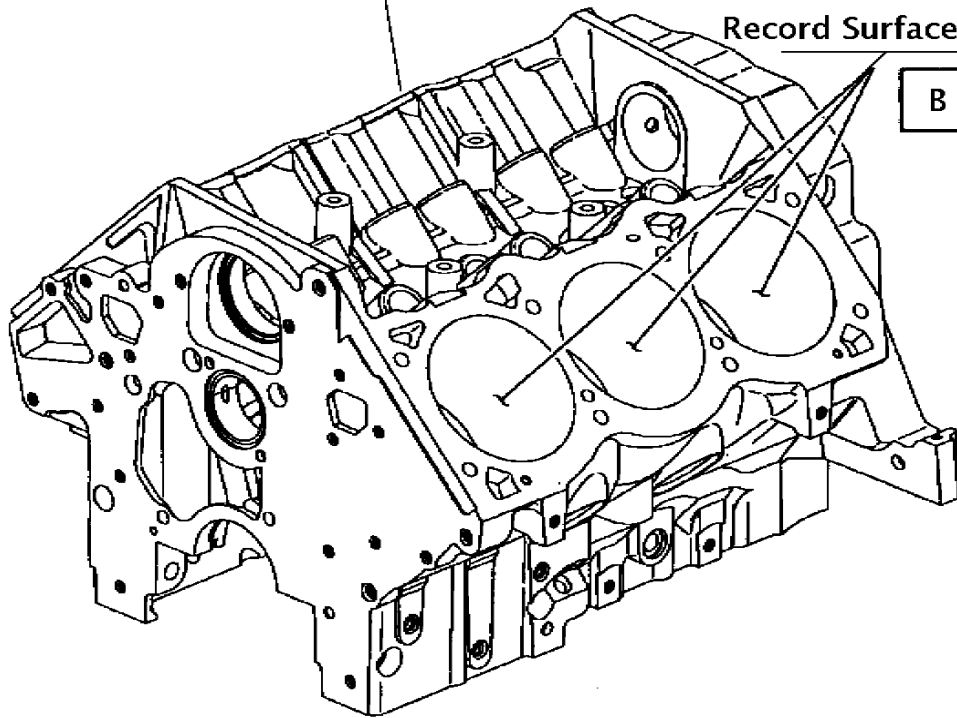
Section	Sheet
3	1

Check engine block for cleanliness

A

Record Surface Finish

B



**Description of Operation**

- A Check engine block, camshaft tunnel, lifter bores, oil galleries, gasket surfaces, and cylinder bores for cleanliness.
- B Check and record cylinder bore surface finish Ra and confirm bore diameters / run number.
- C Record appropriate data on form shown in Annex A.14 of IIIG test procedure.

**Specification**

**View**

Engine block cleanliness inspection and cylinder surface finish/size recording

**Section**

3

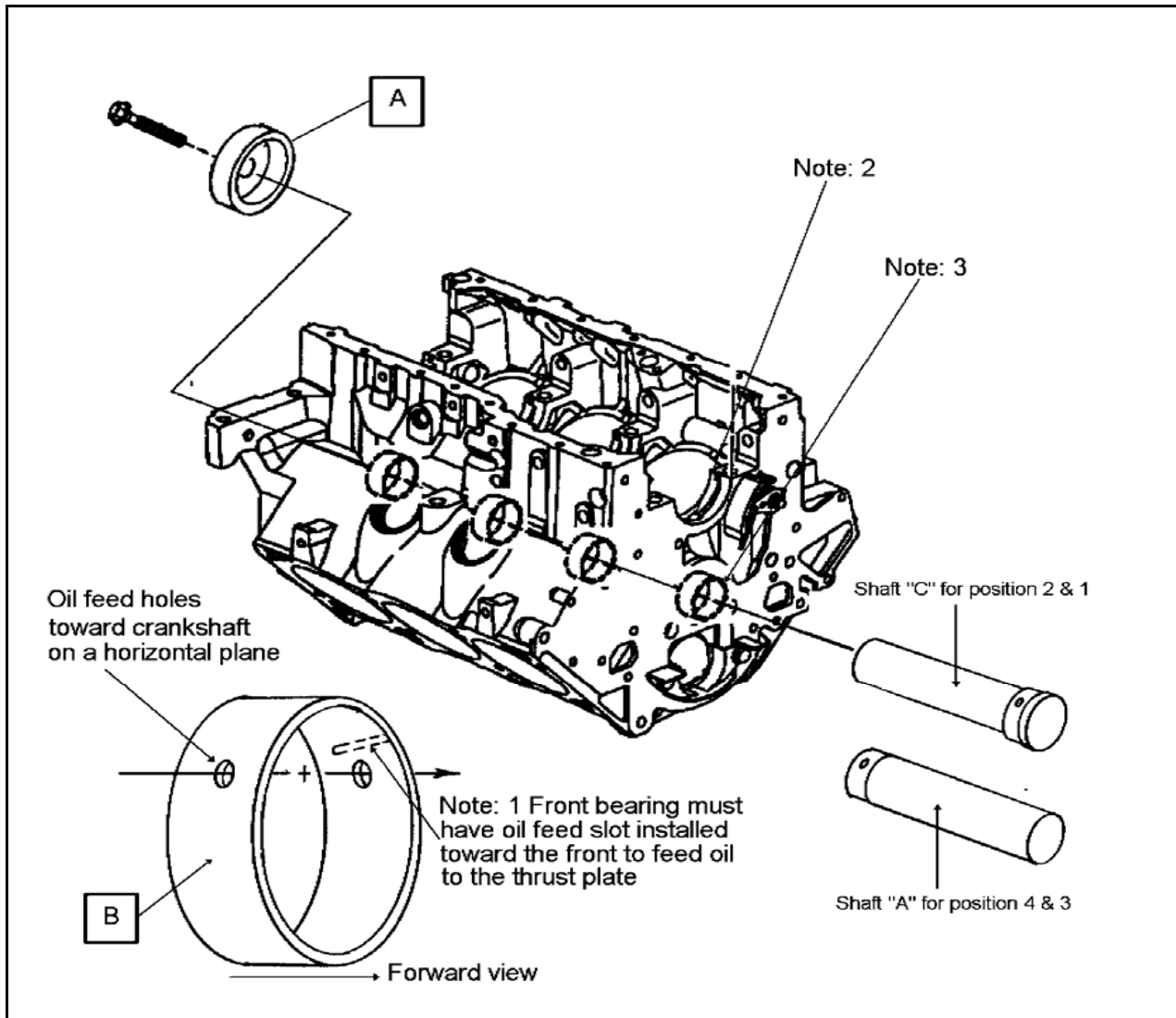
**Sheet**

2

REV	Date	Revision History
1	01/02/98	Block-9
2	06/22/06	Add item "C"

**Short Block Assembly**

**Sequence IIIF**



**Description of Operation**

A Install camshaft bearings using OHT3F-019-1 camshaft bearing installation tool. Sections:  
A for #4 rear & #3 intermediate  
C for #2 intermediate and #1 front

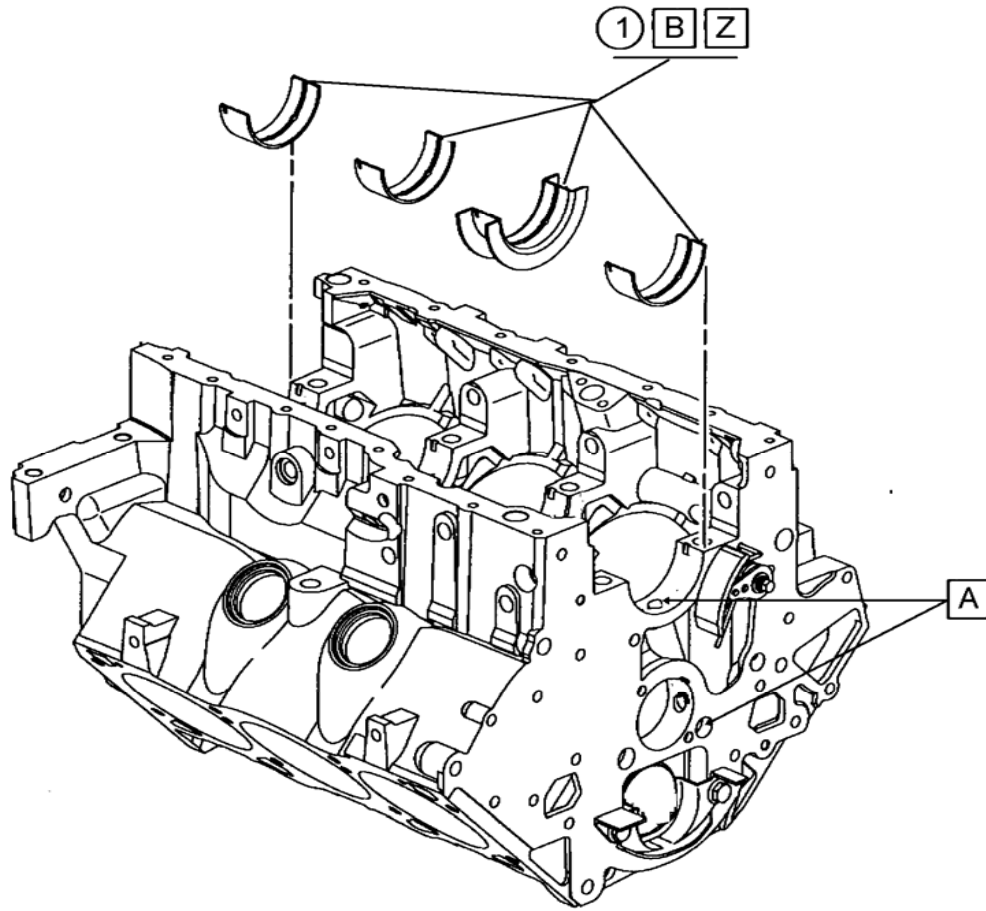
B Lubricate bearing bore and bearing OD. with EF-411. Install bearings with the oil feed holes positioned toward the crankshaft on a horizontal plane. See view "B" and Note: 1

**Specification**

1	Bearing camshaft #1 & #4 OHT3F-028-09
2	Bearing camshaft #2 & #3 OHT3F-028-10 Both bearings are included in OHT3F-042-2

REV	Date	Revision History
1	01/02/98	Block-10
<b>Short Block Assembly</b>		<b>Sequence III F</b>

<b>View</b>	
<b>Short Block</b>	
Camshaft bearing positioning and installation	
<b>Section</b>	<b>Sheet</b>
3	3



**Description of Operation**

- A Using compressed air, blow through each oil gallery feed from the main bearing support through the camshaft bearings to dislodge any babbit material that might have come off the camshaft bearings during installation. Use an inspection light to ensure proper alignment of the camshaft bearings and that all debris has been removed from the main and lifter oil galleries.
- B Check the upper main bearing bores for cleanliness and install the upper main bearings in the engine block.
- Z Lubricate with EF-411

**Specification**

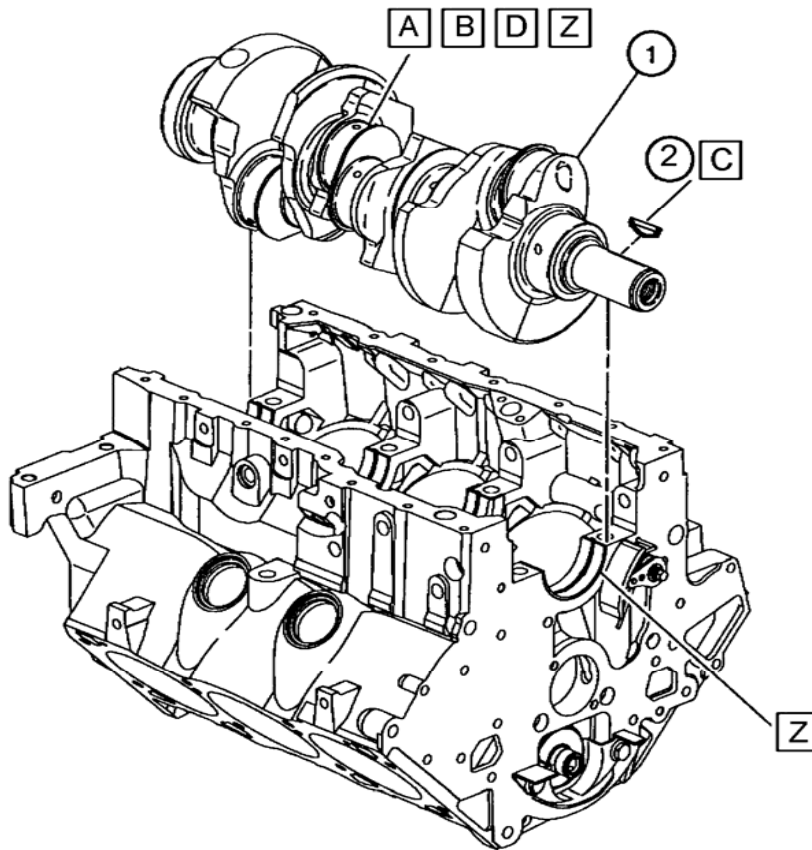
- 1 OHT3F-042-2  
 OH-101 (1,3,4, Upper)  
 OH-102 (1,3, Lower)  
 OH-103 (4 Lower)  
 OH-104 (2 Lower)  
 OH-105 (2 Upper)

REV	Date	Revision History
1	01/03/98	Block-11

View
<b>Short Block</b>
Upper main bearing inspection and installation

<b>Short Block Assembly</b>	<b>Sequence IIIF</b>
-----------------------------	----------------------

Section	Sheet
3	4



**Description of Operation**

- A Clean the crankshaft using an approved commercial cleaning agent followed by degreasing solvent and Mylar strip polishing cloth (use Mylar polishing cloth only if journals are nicked or oxidized, Do Not use to remove varnish). The final step should be degreasing solvent and nylon bristle brushing of the oil galleries. Spray crankshaft with 50/50 solution and blow excess with compressed air.
- B Check journal diameters.  
Mains 63.470 - 63.495mm  
Rods 57.1170 - 57.1475mm
- C Install key
- D Install crankshaft in engine block using care to not move the upper main bearings.
- Z Lubricate with EF-411

**Specification**

- 1 24502168 Crankshaft
  - 2 12563282 Key
- Mylar Tape  
Q135 Metalite 3µ 1½ wide roll

**View**

**Short Block**

Crankshaft cleaning, inspection, and installatio

**Section**

3

**Sheet**

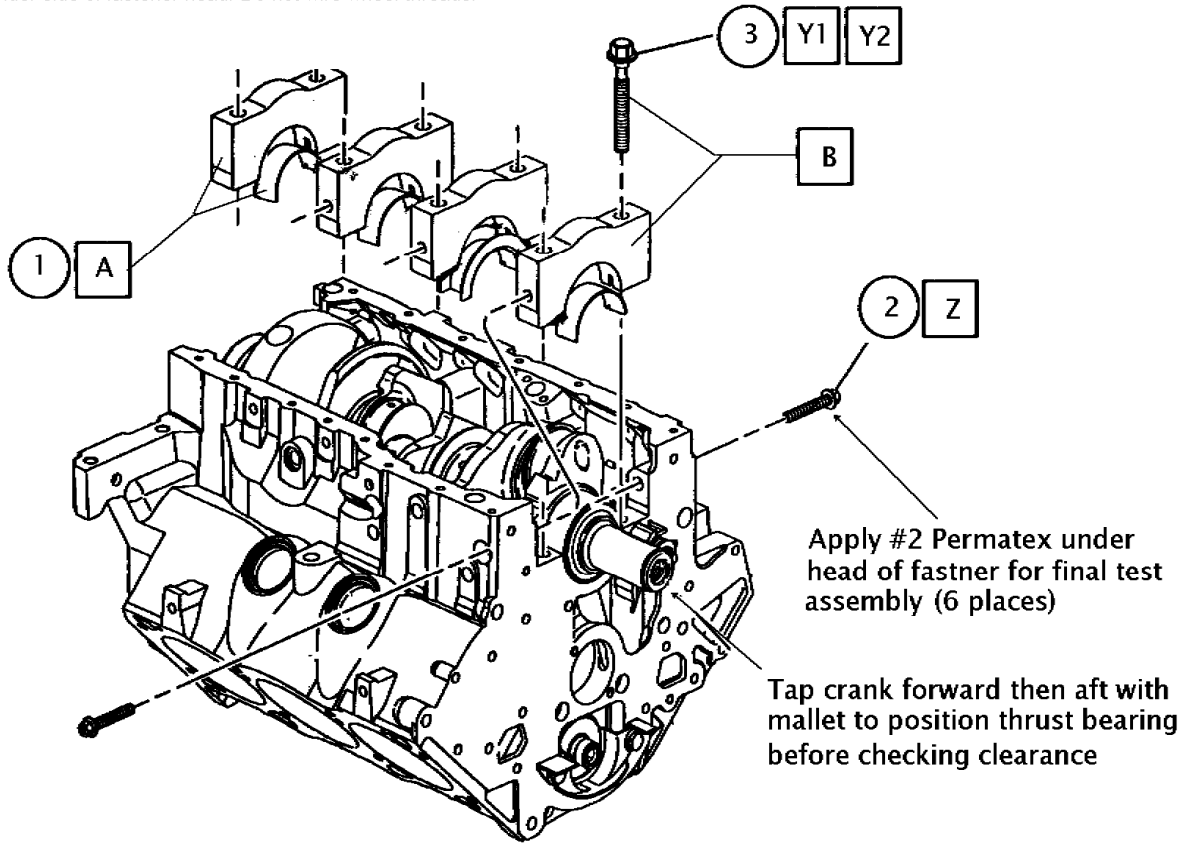
5

REV	Date	Revision History
1	01/03/98	Block-12
2	12/01/04	Change to mineral spirits
3	06/22/06	Update text, add mylar tape part number, change key from (25534912 to 12563282)

**Short Block Assembly**

**Sequence IIIF**

Use new fasteners for each test. Wire wheel sealer from under side of fastener head. Do not wire wheel threads.



**Description of Operation**

- A Install lower main bearings into main caps.
- B Install main cap with new fasteners as guides and draw into position using very light pressure by hand with speed handle and socket in crisscross pattern.
- C Install main cap side bolts
- Y1 Tighten all main bolts to 70 Nm to fully seat main caps and then loosen the bolts 360° counterclockwise. Tap crankshaft with mallet to position thrust bearing.\*
- Y2 Torque & Angle  
20Nm then 40Nm + 35°+35°+35° (repeat 3 times from center out) Check crankshaft end play 0.076 - 0.279mm
- Y3 Torque & Angle 15Nm + 45° (See note on sealer usage)

**Specification**

- 1 OHT3F-042-2 Bearing kit
- 2 24505576 Bolt side (6)  
See note on sealer usage
- 3 24503056 Bolt main cap (8)

REV	Date	Revision History
1	01/10/98	Block-13
2	06/22/06	Update view, fastener usage and prep, also clearance spec.
3	03/05/10	Update view, fastener usage and prep.

View	
<b>Short Block</b>	
Lower main bearing and crankshaft final test installation	

Section	Sheet
3	6

**Short Block Assembly**

**Sequence IIIF**



			<b>Description of Operation</b>	
			A	<p>Confirm run number and proper grade piston selections.</p> <p>Clean pistons with degreasing solvent followed by air dry and wipe with lint-free cloth.</p> <p>Clean rods by soaking in degreasing solvent for two hours followed by spray with 50/50 EF411 and degreasing solvent.</p>
			B	<p>Lubricate piston pin and connecting rod with EF-411. Install one piston pin retainer clip into the retaining groove. Install the con rod and piston pin. (Note: dimple on con rod is for manufacturing only) Install the second retainer clip. Make sure both retainer clips are properly seated in their grooves.</p>
			<b>Specification</b>	
			1	OHT3F-053-1 Grade 12 test piston set
			2	OHT3F-054-1 Grade 34 test piston set
			3	OHT3F-055-1 Grade 56 test piston set
			4	OHT3F-014-1Piston pin set
			5	OHT3F-012-1 Retainer clip set
			6	12574505 Rod Powdered Metal
REV	Date	Revision History	<b>View</b>	
1	01/03/98	Block-14	<b>Piston, Pin and Connecting Rod</b>	
2	11/03/04	Add part numbers for "Cast" and "Powdered Metal" Rods See "6"	Piston pin and Connecting Rod assembly	
3	01/31/06	Removed Cast Rod information		
4	06/22/06	Update piston and rod cleaning procedure and assembly note on dimple		
			Section	Sheet
<b>Short Block Assembly</b>		<b>Sequence IIIF</b>	3	7

**Sequence III G**  
**Piston, Cylinder Bore, & Ring Gap Information**

Piston Grade / Run	Target Bore Size	Master Ring Gage	Target Ring Gap	Piston Size
12 / 1	96.52	96.53	Top 0.635 2nd 1.067	96.482 - 96.497
12 / 2	96.54	96.53	Top 0.635 2nd 1.067	96.482 - 96.497
34 / 3	96.56	96.57	Top 0.635 2nd 1.067	96.522 - 96.537
34 / 4	96.58	96.57	Top 0.635 2nd 1.067	96.522 - 96.537
56 / 5	96.60	96.61	Top 0.635 2nd 1.067	96.562 - 96.577
56 / 6	96.62	96.61	Top 0.635 2nd 1.067	96.562 - 96.577

All piston ring gaps to be  $\pm 0.051\text{mm}$   
 As measured in cylinder bore using Starrett Taper Gage #270

RUN	OHT PART NUMBER	DESCRIPTION	COLOR	STRIPE(S)
1	3F050-TOP 1	TOP RING	PINK	ONE (1)
	3F050-SECOND 1	SECOND RING	YELLOW	ONE (1)
2	3F050-TOP 2	TOP RING	PINK	TWO (2)
	3F050-SECOND 2	SECOND RING	YELLOW	TWO (2)
3	3F051-TOP 3	TOP RING	PINK	THREE (3)
	3F051-SECOND 3	SECOND RING	YELLOW	THREE (3)
4	3F051-TOP 4	TOP RING	BROWN	ONE (1)
	3F051-SECOND 4	SECOND RING	GREEN	ONE (1)
5	3F052-TOP 5	TOP RING	BROWN	TWO (2)
	3F052-SECOND 5	SECOND RING	GREEN	TWO (2)
6	3F052-TOP 6	TOP RING	BROWN	THREE (3)
	3F052-SECOND 6	SECOND RING	GREEN	THREE (3)

**NOTE: PAINT IDENTIFICATION MUST BE REMOVED FROM RING PRIOR TO GAP MEASUREMENT**

**Description of Operation**

Confirm correct ring grade and gaps for the engine run / piston grade. No piston ring gap adjustments are allowed.

To check ring gap, use Starrett Taper Gage #270 and measure the gap in the finished cylinder bore

**Specification**

- 1 OHT3F-050-RN1-1
- 2 OHT3F-050-RN2-1
- 3 OHT3F-051-RN3-1
- 4 OHT3F-051-RN4-1
- 5 OHT3F-052-RN5-1
- 6 OHT3F-052-RN6-1

REV	Date	Revision History
1	06/18/02	Block-15
2	4/28/03	Update color coding
3	06/22/06	Expand drawings and add section 3 sheet 8A for additional information
4	06/22/06	Expand drawings and add section 3 sheet 8A for additional information
5	03/05/10	Deleted OHT ring gages and allowed measurement in cylinder block
5	04/10/12	Revised target bore size for 12 / 2 piston and updated ring part numbers

**View**

**Piston Ring**

Piston ring installation and clearance

**Section**

**Sheet**

3

8

**Short Block Assembly**

**Sequence III F**

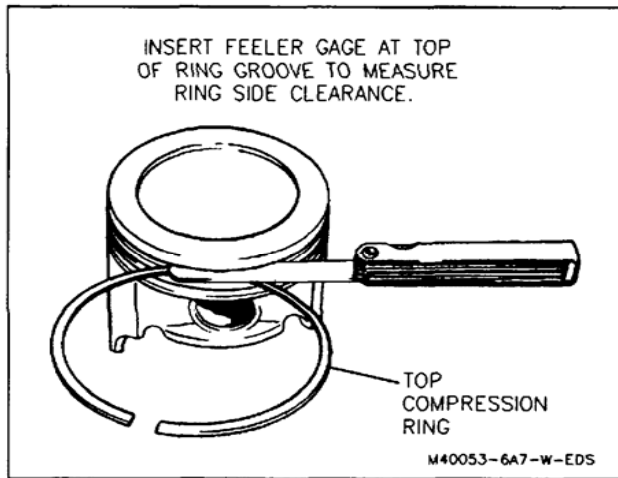


Figure 69 - Measuring Piston Ring Side Clearance

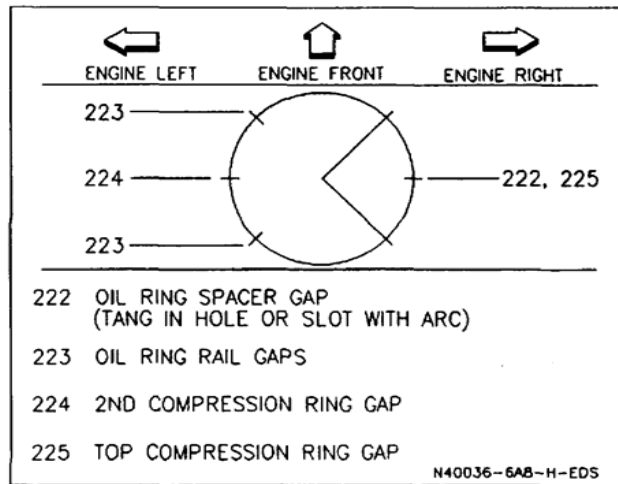


Figure 64 - Piston Ring Gap Location

**Description of Operation**

Check for proper ring side clearance.  
 Top & 2nd. 0.033 - 0.079mm  
 Oil control 0.023 - 0.201mm

Position rings on piston according to ring gap stagger chart. Orientation of oil control ring rails and expander are unidirectional.

Lubricate assembly with EF-411

**Specification**

**View**

Piston ring installation, orientation, and clearance information

**Section**

**Sheet**

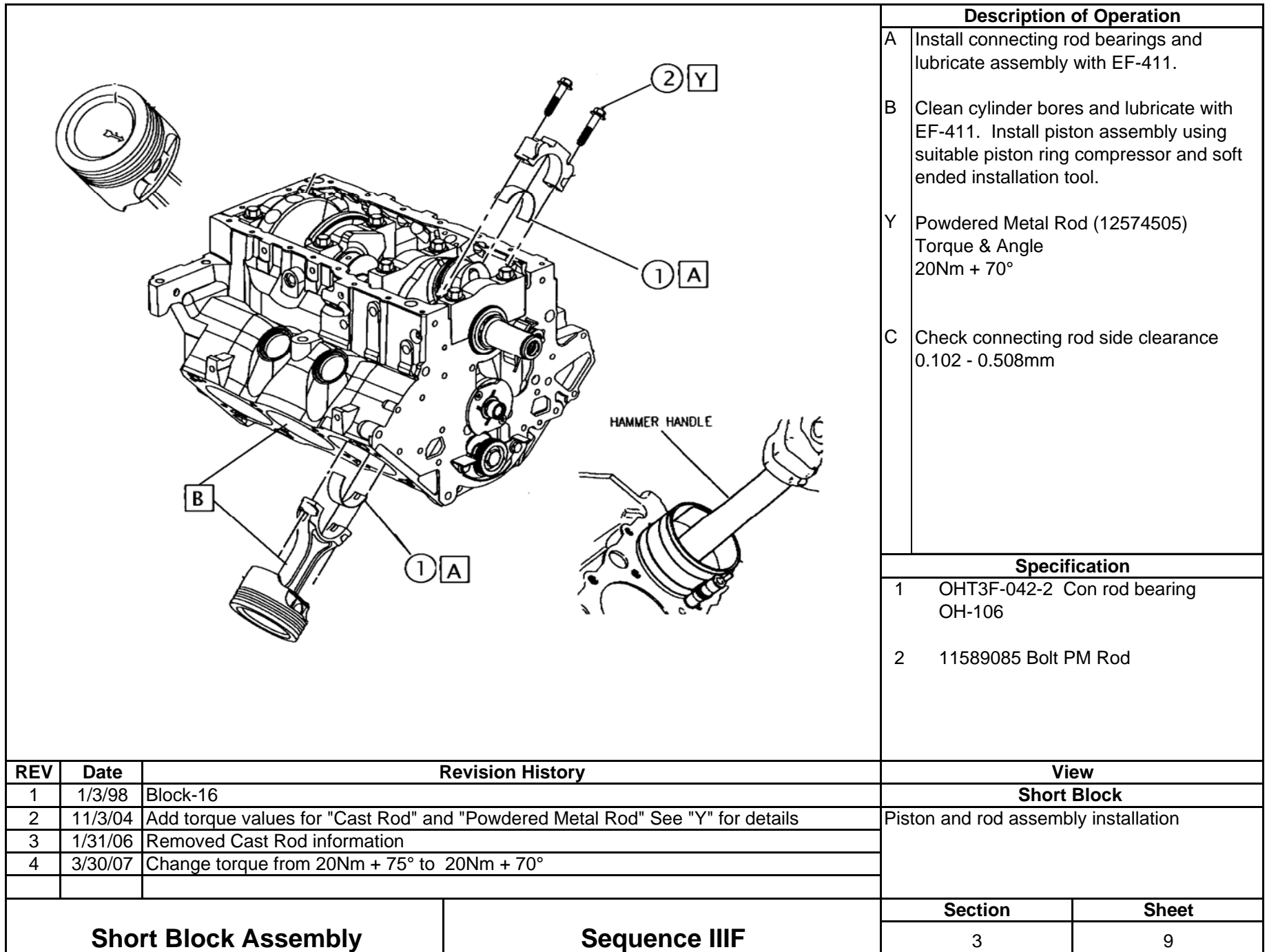
3

8A

REV	Date	Revision History
1	6/22/06	Ring orientation

**Short Block Assembly**

**Sequence IIIF**



Description of Operation	
A	Install connecting rod bearings and lubricate assembly with EF-411.
B	Clean cylinder bores and lubricate with EF-411. Install piston assembly using suitable piston ring compressor and soft ended installation tool.
Y	Powdered Metal Rod (12574505) Torque & Angle 20Nm + 70°
C	Check connecting rod side clearance 0.102 - 0.508mm

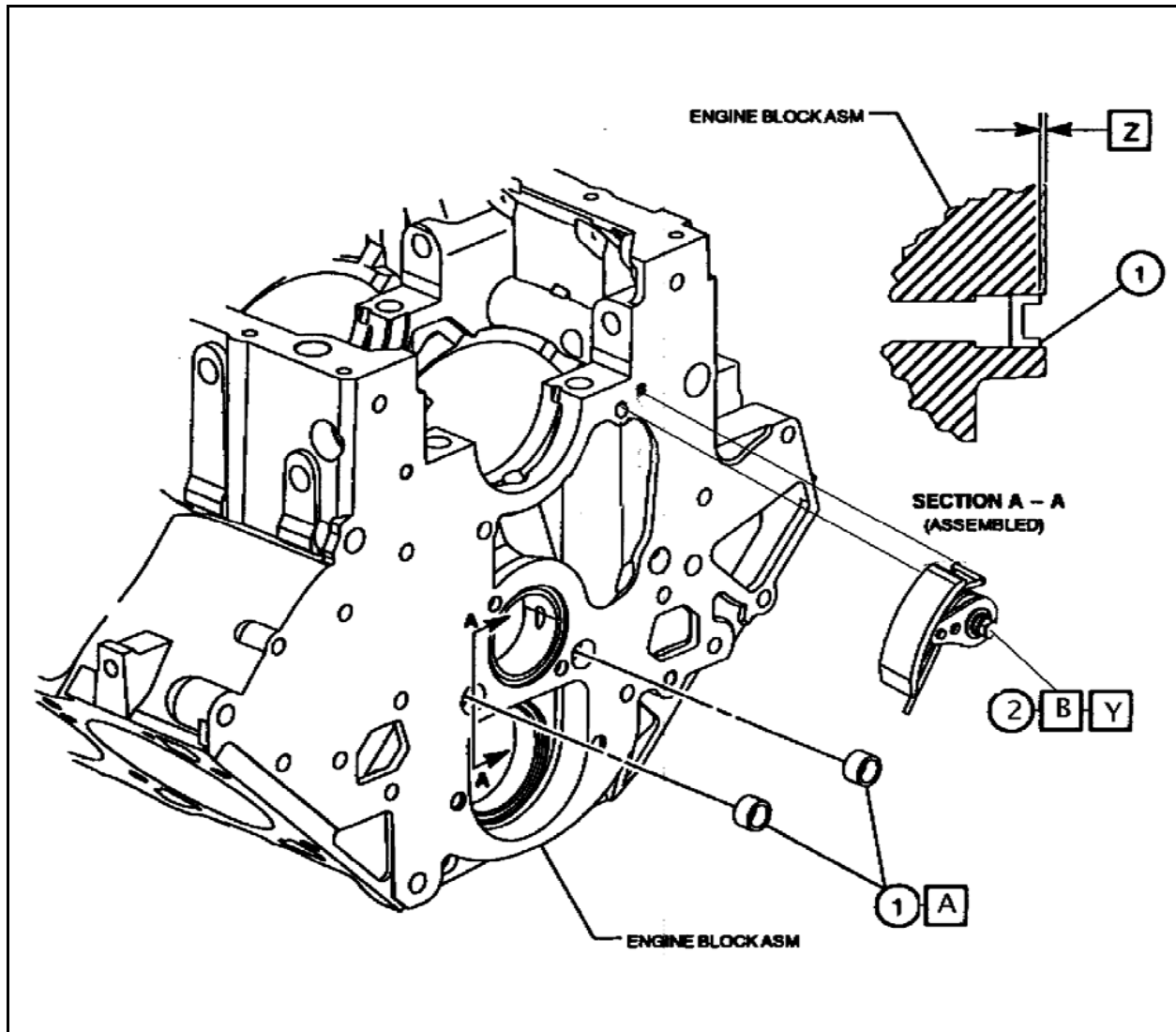
Specification	
1	OHT3F-042-2 Con rod bearing OH-106
2	11589085 Bolt PM Rod

REV	Date	Revision History
1	1/3/98	Block-16
2	11/3/04	Add torque values for "Cast Rod" and "Powdered Metal Rod" See "Y" for details
3	1/31/06	Removed Cast Rod information
4	3/30/07	Change torque from 20Nm + 75° to 20Nm + 70°

View	
Short Block	
Piston and rod assembly installation	

Short Block Assembly	Sequence IIIF
----------------------	---------------

Section	Sheet
3	9



Description of Operation	
A	Install oil gallery plugs, see cross section A - A.
B	Install damper assembly
Y	Torque 22Nm
Z	Locate cup plug 1.5 +/- 0.75mm below front face of block.

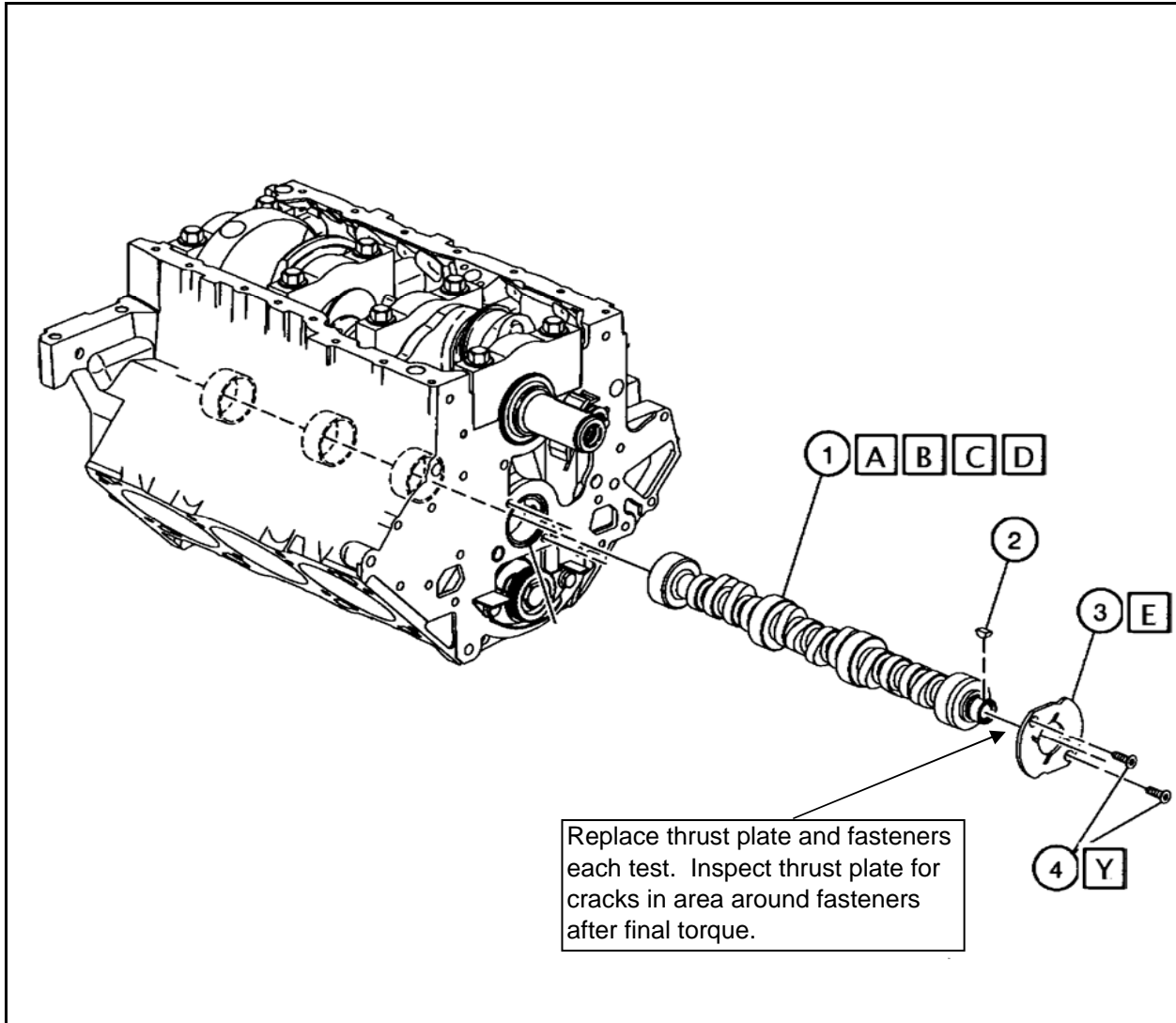
Specification	
1	3835577 Plug, oil gallery
2	24503893 Damper assembly

REV	Date	Revision History
1	1/3/98	Block-17

View	
<b>Short Block</b>	
Oil gallery plugs and timing chain damper	

<b>Short Block Assembly</b>	<b>Sequence IIIF</b>
-----------------------------	----------------------

Section	Sheet
3	10



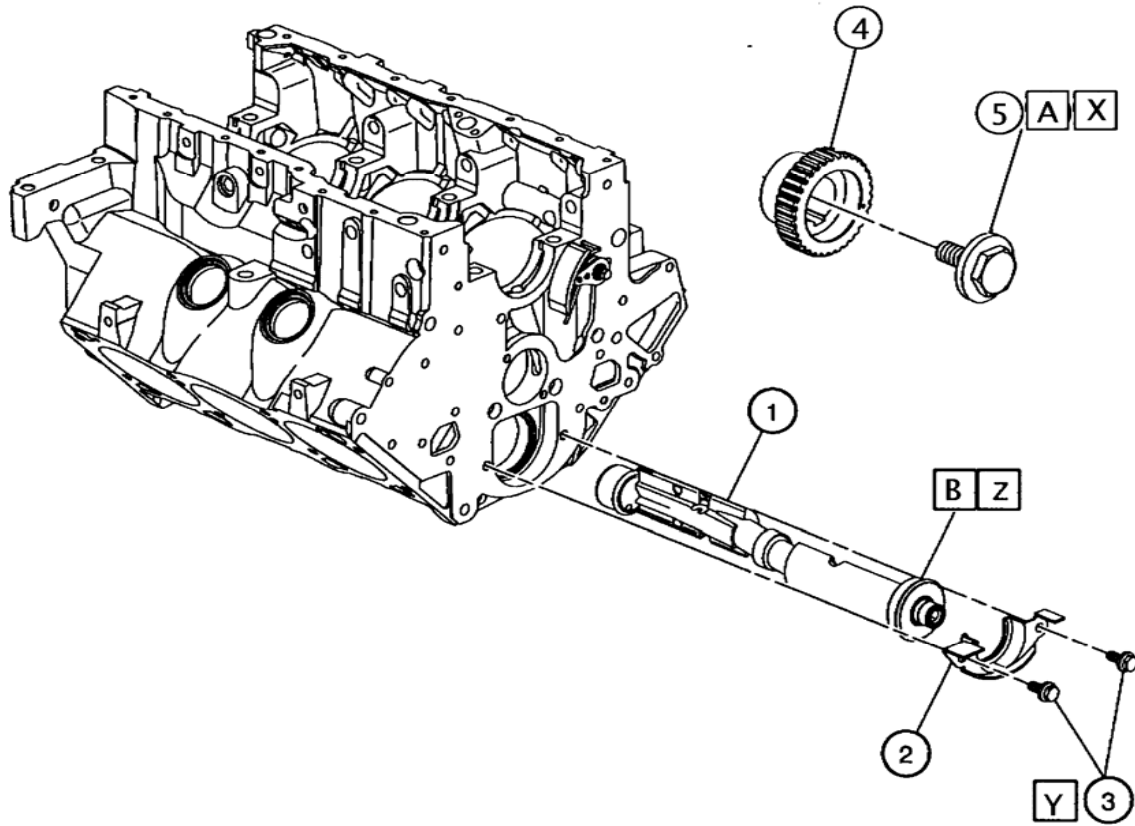
Description of Operation	
A	Check and de-burr if necessary, the front thrust surface of the camshaft.
B	Clean camshaft with degreasing solvent and very clean shop towel. Note: make sure all grinding residue is removed before continuing.
C	Make pre-test measurements at the rear side of each lobe and record to the nearest 0.001mm.
D	Lubricate the camshaft journals only (not lobes) with EF-411 and install. Note: If test oil is known, lubricate journals and lobes with test oil and install
E	Lubricate thrust plate and install
Y	Torque 15Nm

Specification	
1	OHT3F-008-6 Non-Phosphate Coated <b>(For Use in IIIF Testing Only)</b>
2	24500618 Key (Replace each test)
3	OHT3F-011-2 Thrust plate (0.152")
4	25519242 Bolt (Replae each test)

REV	Date	Revision History
1	1/13/98	Block-18
2	12/1/04	Change to mineral spirits
3	6/22/06	Update usage information
4	3/30/07	Update "D" pre-test lubrication directions

View	
<b>Short Block</b>	
Camshaft cleaning, measurement, and installation	

<b>Short Block Assembly</b>	<b>Sequence IIIF</b>	<b>Section</b>	<b>Sheet</b>
		3	11



**Description of Operation**

- A Secure balance shaft in a smooth jawed vice and install drive gear and bolt.
- B Inspect balance shaft and roller bearing for cleanliness and install.
- X Torque & Angle 22Nm + 70°
- Y Torque 30Nm
- Z Lubricate with EF-411

**Specification**

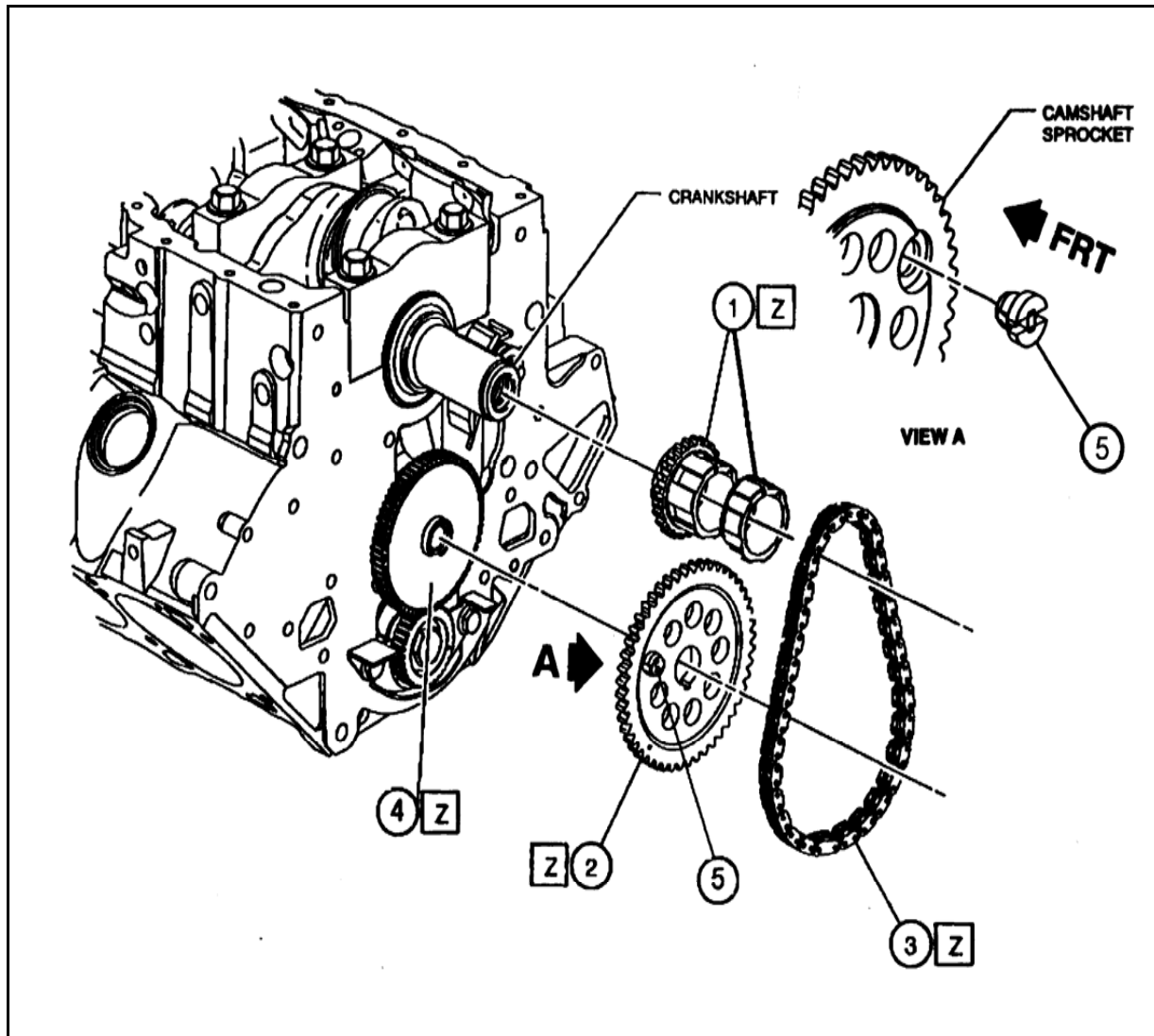
- 1 24502388 Shaft Assembly or 24506557
- 2 24500374 Retainer
- 3 24500055 Bolt
- 4 24503524 Gear
- 5 24501367 Bolt

REV	Date	Revision History
1	1/5/98	Block-19
2	6/22/06	Add 24506557 shaft assembly part number

View
<b>Short Block</b>
Balance shaft inspect & install

<b>Short Block Assembly</b>	<b>Sequence III F</b>
-----------------------------	-----------------------

<b>Section</b>	<b>Sheet</b>
3	12



**Description of Operation**

Timing gear set. See part number information.

A Install magnet See view "A"

Z Lubricate with EF-411

Note: Inspect balance shaft and gears and replace as necessary if damage to gear teeth and / or thrust surface is evident.

**Specification**

1	OHT3F-036-1 Sprocket, 2pc.
2	24505306 Sprocket, camshaft
3	24504668 Chain
4	24504792 Gear
5	10456195 Magnet

REV	Date	Revision History
1	1/5/98	Block-20

**View**

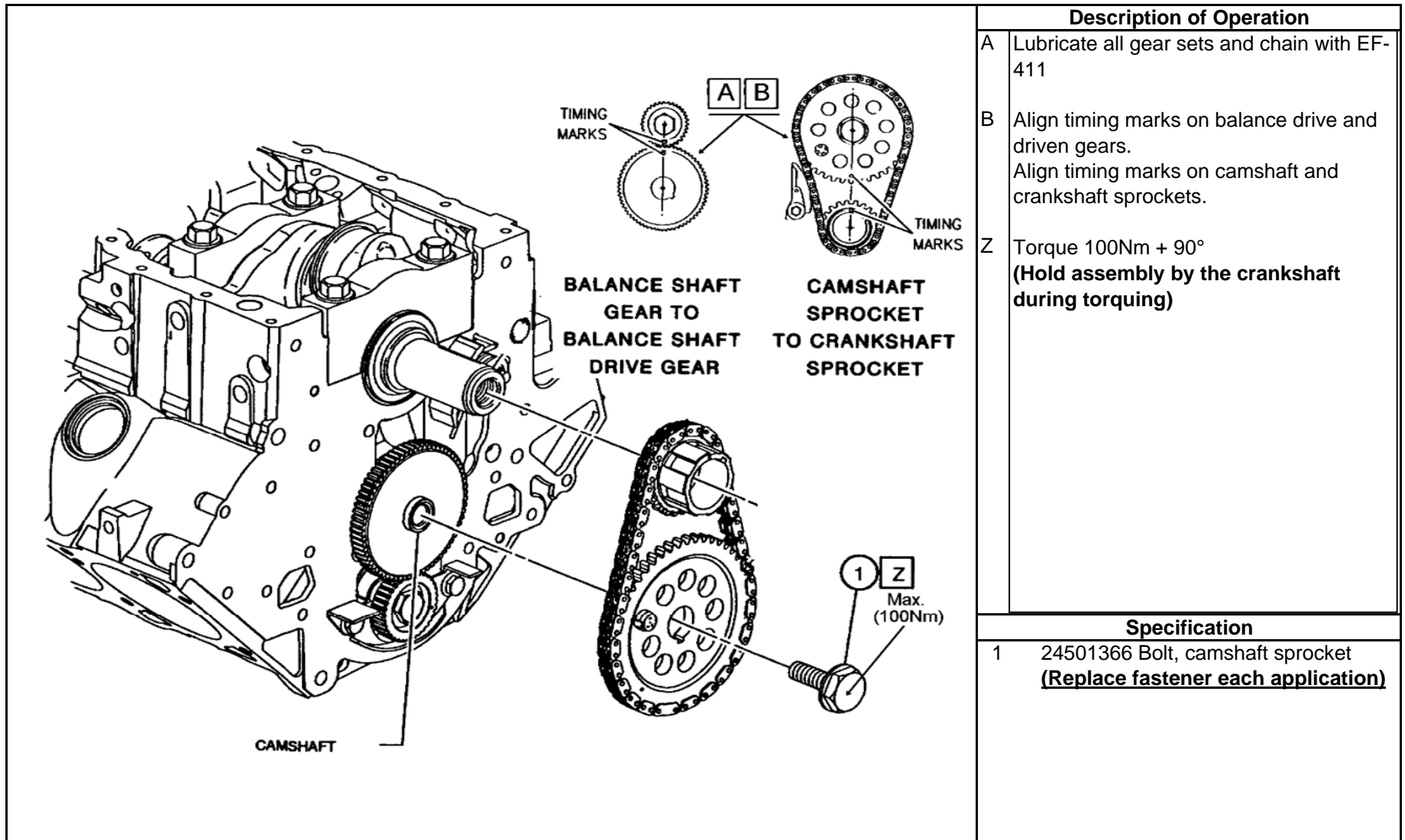
**Short Block**

Timing gear set

<b>Short Block Assembly</b>	<b>Sequence IIIF</b>
-----------------------------	----------------------

<b>Section</b>	<b>Sheet</b>
3	13



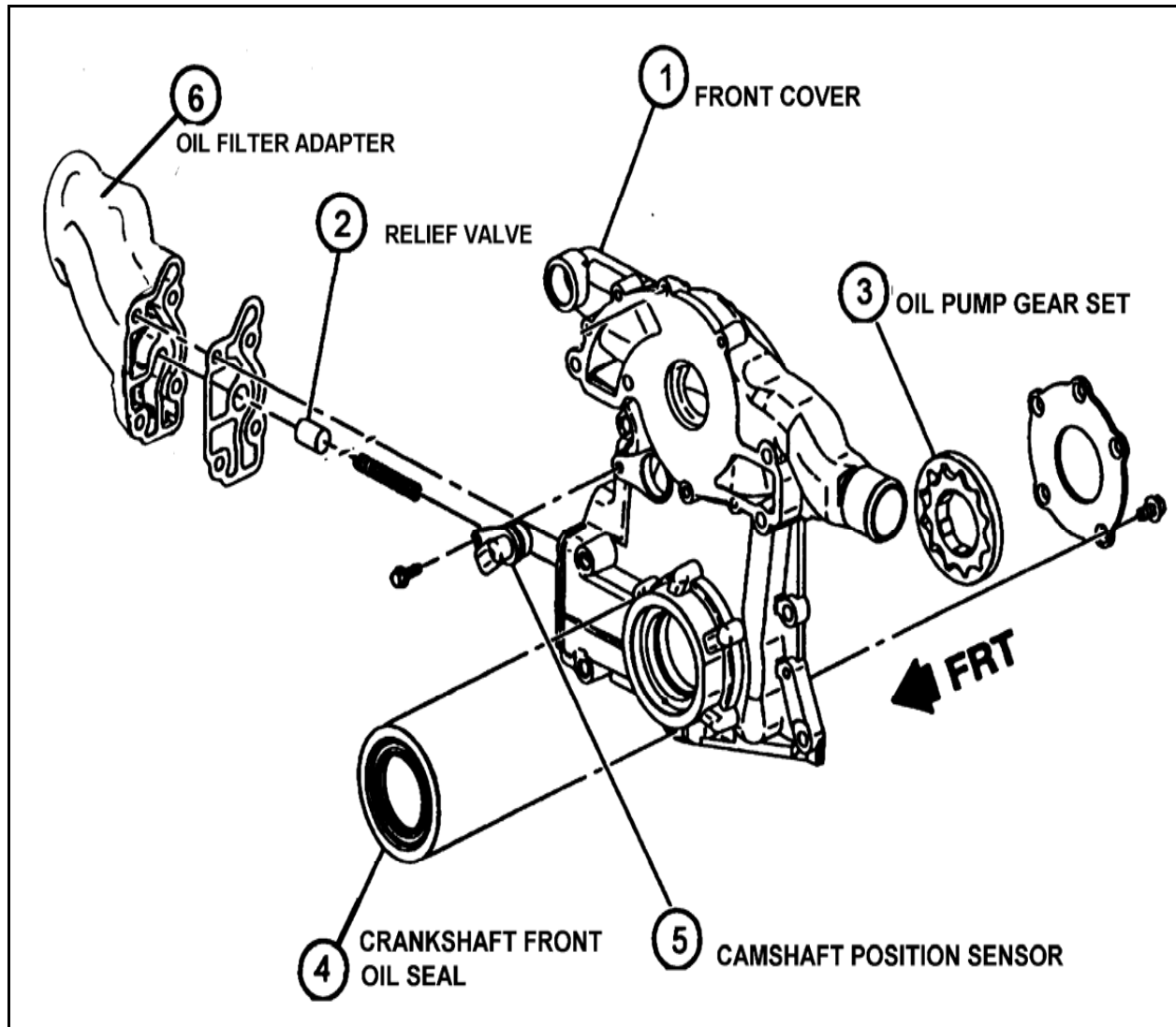


Specification	
1	24501366 Bolt, camshaft sprocket <b><u>(Replace fastener each application)</u></b>

REV	Date	Revision History	View
1	1/5/98	Block-21	<b>Short Block</b>
			Timing gear set alignment & torque
<b>Short Block Assembly</b>		<b>Sequence IIIF</b>	<b>Section</b>
			<b>Sheet</b>
			3
			14

## **Section 4**

### **Front Cover, Rear Cover, and Sump**



**Description of Operation**

Assembly view

**Specification**

1	OHT3F-085-1 Front Cover
2	25530949 Valve, oil pressure relief
3	24505433 Oil pump gear set
4	OHT3G-092-1 Seal
5	10456148 Camshaft position sensor
6	OHT3F-080-1 Adapter, oil filter

REV	Date	Revision History
1	01/05/98	Block-22
2	4/28/03	Change front cover over to OHT part number
3	11/03/04	Change front seal from 24504098 to OHT3G-092-1

**View**

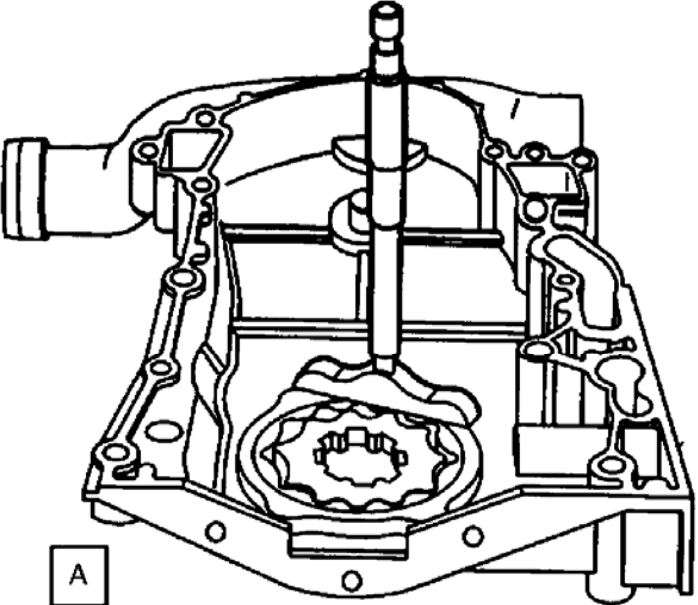
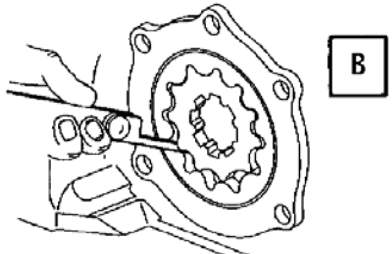
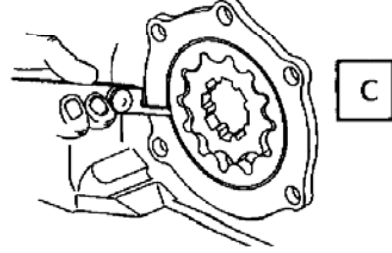
**Front Cover**

Front cover assembly view

**Front Cover, Rear Cover, & Sump**

**Sequence IIIF**

<b>Section</b>	<b>Sheet</b>
4	1

			Description of Operation	
 <p><b>A</b> Measuring gear end clearance drop in housing</p>  <p><b>B</b> Measuring gear tip clearance</p>  <p><b>C</b> Measuring outer gear dia. clearance</p>			<p><b>A</b> Measure gear drop in housing 0.025 - 0.153mm</p> <p><b>B</b> Measure gear tip clearance; 0.076 - 0.127mm (0.003 - 0.007in) as measured with gear teeth in mesh with opposite side.</p> <p><b>C</b> Measure outer gear diameter clearance 0.025 - 0.127mm (0.001 - 0.005in)</p> <p>Note: Inspect front cover oil gear housing for evidence of wear from previous test. Replace after six tests or as necessary if wear is evident.</p>	
			<b>Specification</b>	
			<b>View</b>	
			<b>Front Cover</b>	
			Oil pump gear clearance	
			<b>Section</b>	<b>Sheet</b>
<b>Front Cover, Rear Cover, &amp; Sump</b>			<b>Sequence III F</b>	
			4	2

REV

Date

Revision History

View

1

01/05/98

Block-23

Front Cover

2

06/22/06

Add usage information

Oil pump gear clearance

3

05/02/13

Increased upper limit for drop in clearance to 0.153 mm

Section

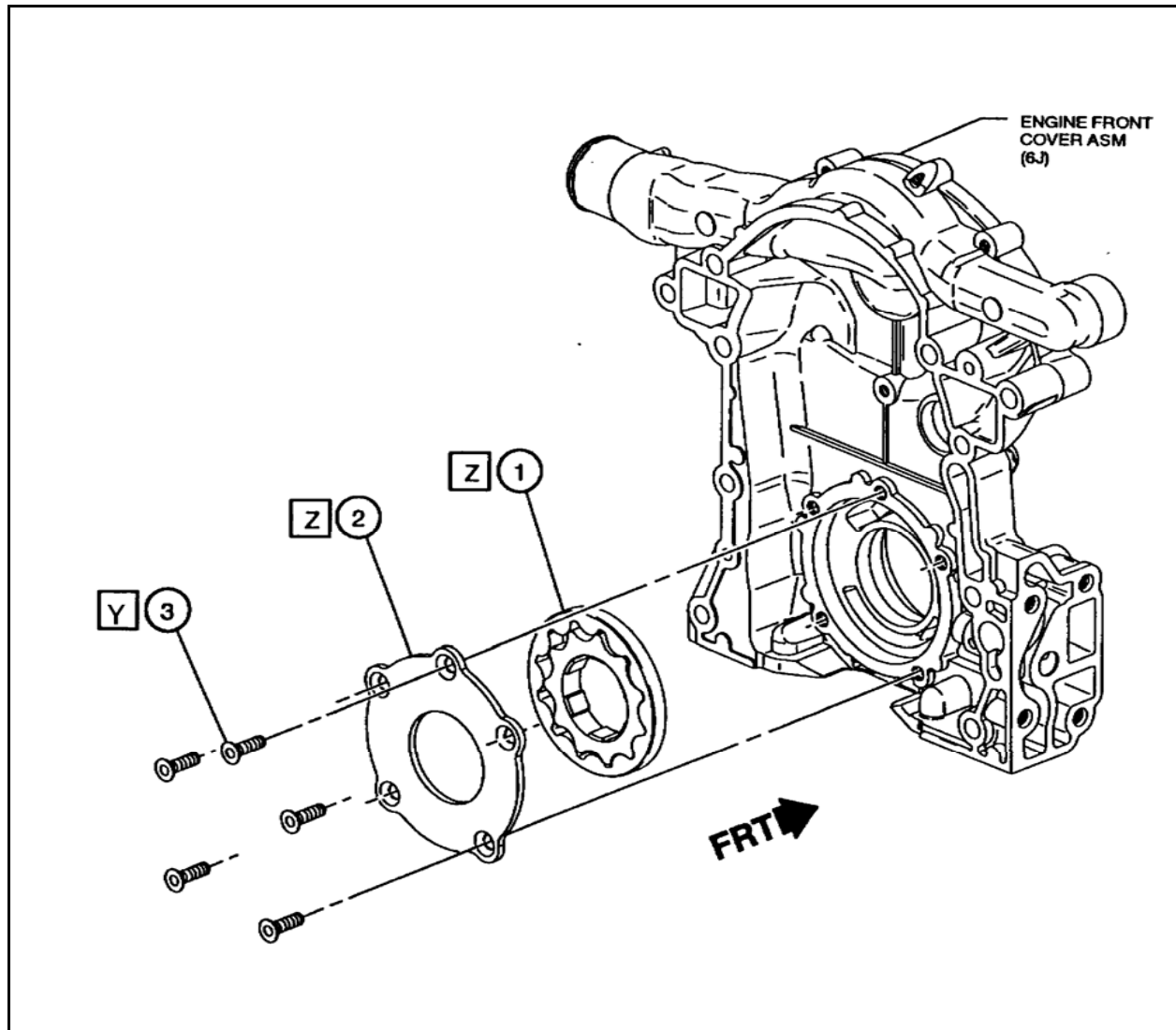
Sheet

Front Cover, Rear Cover, & Sump

Sequence III F

4

2



Description of Operation	
Y	Torque 11Nm
Z	Lubricate with EF-411

Specification	
1	24505433 Gear set
2	25521935 Cover, Gearotor
3	25519242 Bolt

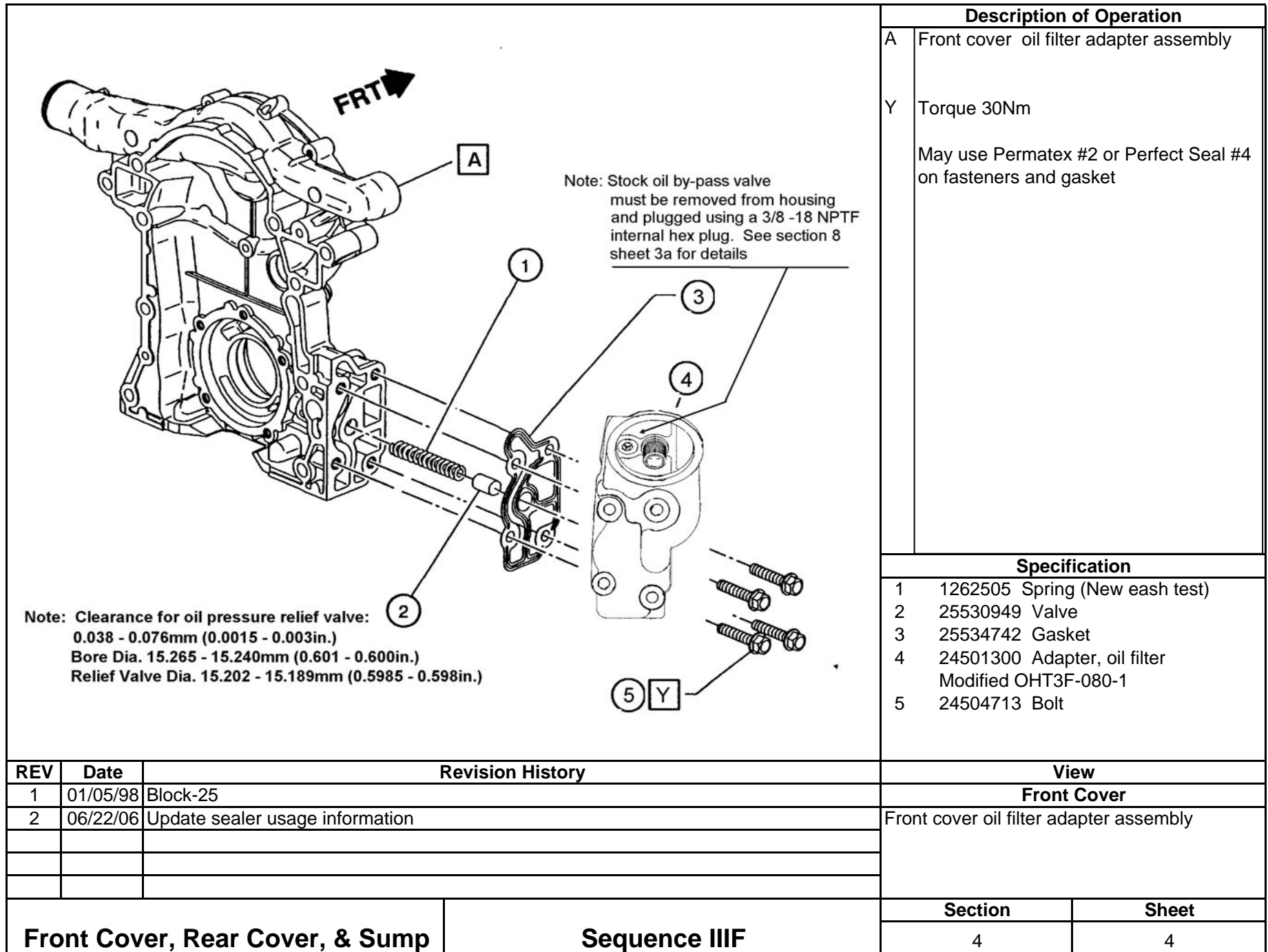
REV	Date	Revision History
1	01/05/98	Block-24
2	5/28/03	Change to OHT front cover

View	
<b>Front Cover</b>	
Front cover oil gear install	

**Front Cover, Rear Cover, & Sump**

**Sequence III F**

Section	Sheet
4	3



**Description of Operation**

A	Front cover oil filter adapter assembly
Y	Torque 30Nm  May use Permatex #2 or Perfect Seal #4 on fasteners and gasket

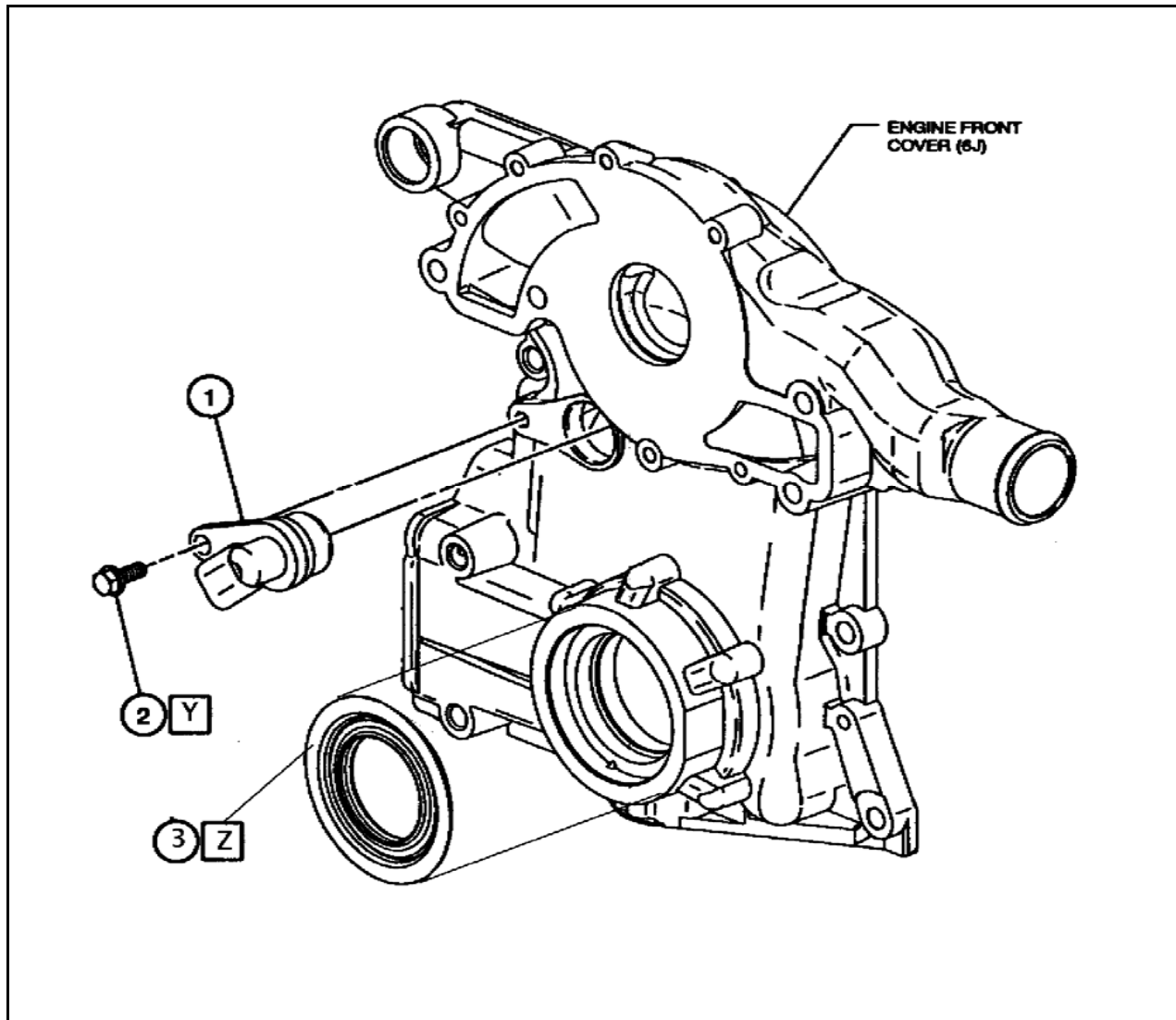
**Specification**

1	1262505 Spring (New eash test)
2	25530949 Valve
3	25534742 Gasket
4	24501300 Adapter, oil filter Modified OHT3F-080-1
5	24504713 Bolt

REV	Date	Revision History
1	01/05/98	Block-25
2	06/22/06	Update sealer usage information

<b>Front Cover, Rear Cover, &amp; Sump</b>	<b>Sequence IIIF</b>	<b>View</b>	
		<b>Front Cover</b>	
		Front cover oil filter adapter assembly	

<b>Section</b>	<b>Sheet</b>
4	4



Description of Operation	
Y	Torque 30Nm
Z	Use a light application of #4 Permatex or RTV, GM part number 12346193 or Dow Corning 3154 around the rear side of the seal where it contacts the front cover.

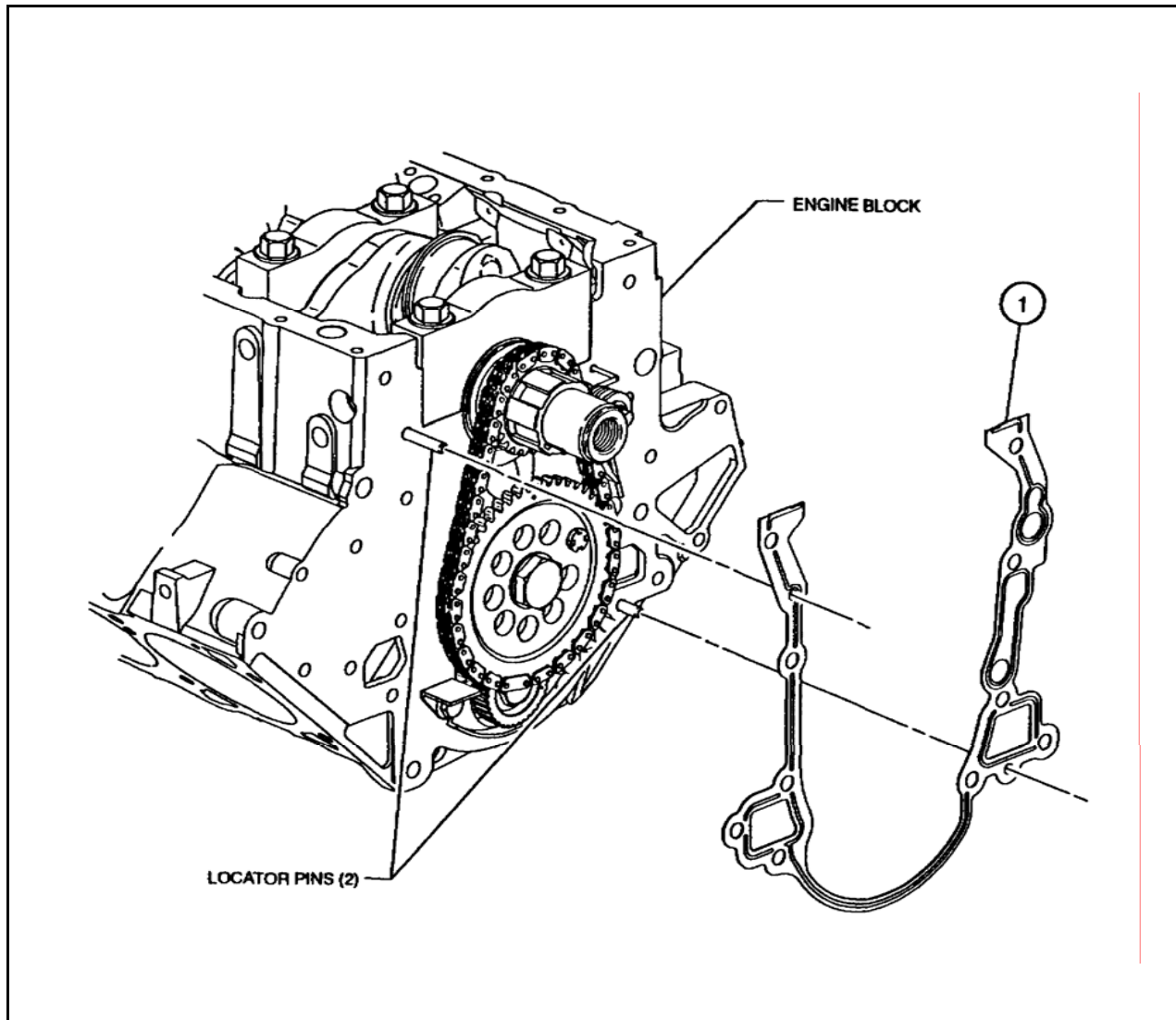
Specification	
1	10456148 Camshaft sensor
2	25526395 Bolt
3	OHT3G-092-1 Seal

REV	Date	Revision History
1	01/05/98	Block-29
2	12/15/03	Add approved silicone sealers
3	11/03/04	Change front seal part number to OHT3G-092-1

View	
<b>Front Cover</b>	
Front cover camshaft sensor and seal install	

<b>Front Cover, Rear Cover, &amp; Sump</b>	<b>Sequence III F</b>
--	-----------------------

Section	Sheet
4	5



**Description of Operation**

Note:  
Perfect seal #4 may be used around coolant passages on gasket.

Specification	
1	12587003 Gasket

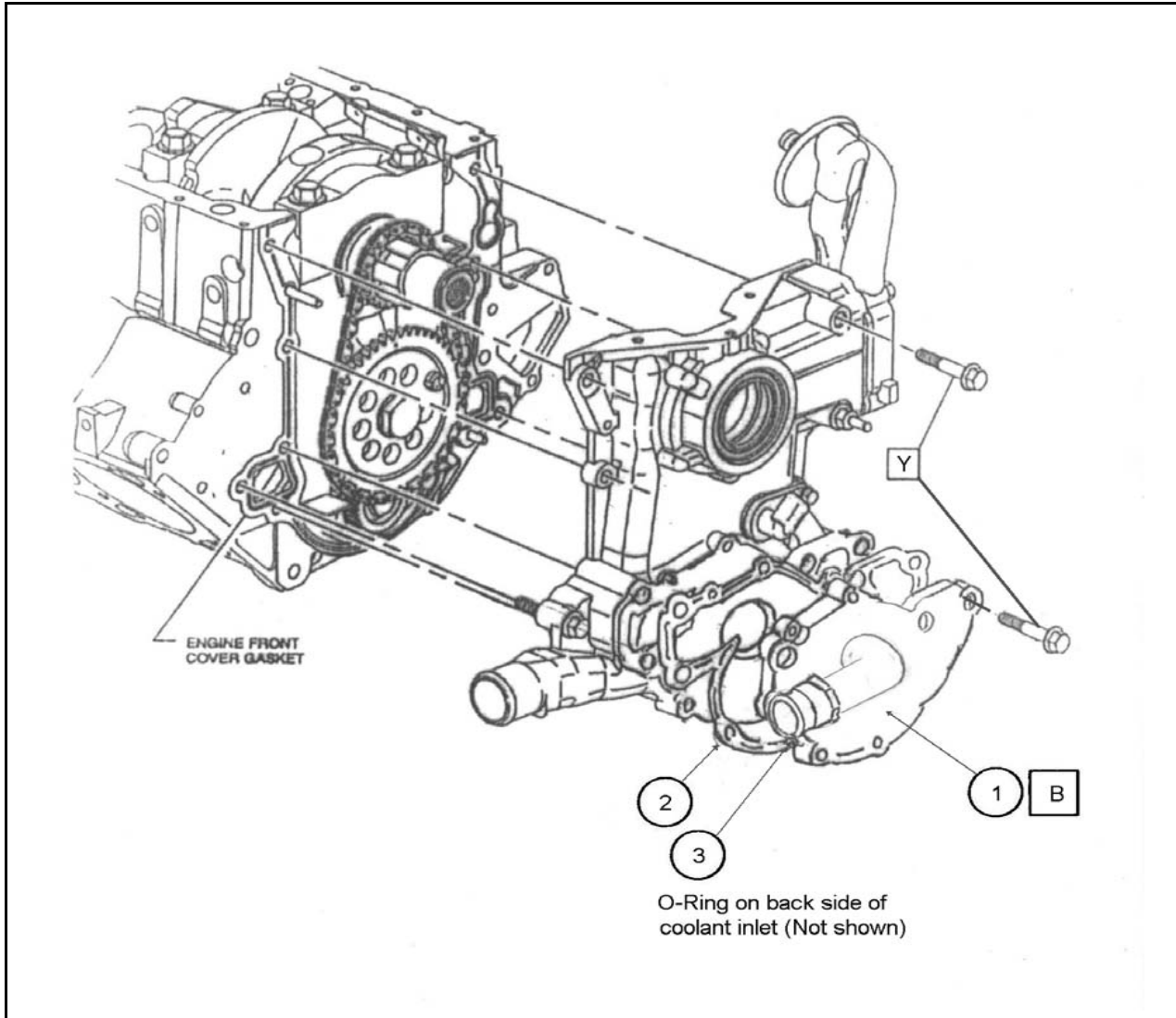
REV	Date	Revision History
1	01/05/98	Block-26
2	03/03/07	Update new gasket 12587003 old number 24502252

View
<b>Front Cover</b>
Front cover gasket install

<b>Front Cover, Rear Cover, &amp; Sump</b>	<b>Sequence IIIF</b>
--	----------------------

Section	Sheet
4	6





Description of Operation	
A	Front cover assembly
B	Install coolant inlet adapter with front cover
Y	Torque 30Nm  Install thermocouple in OHT3F-031 with sensing tip centered in flow.

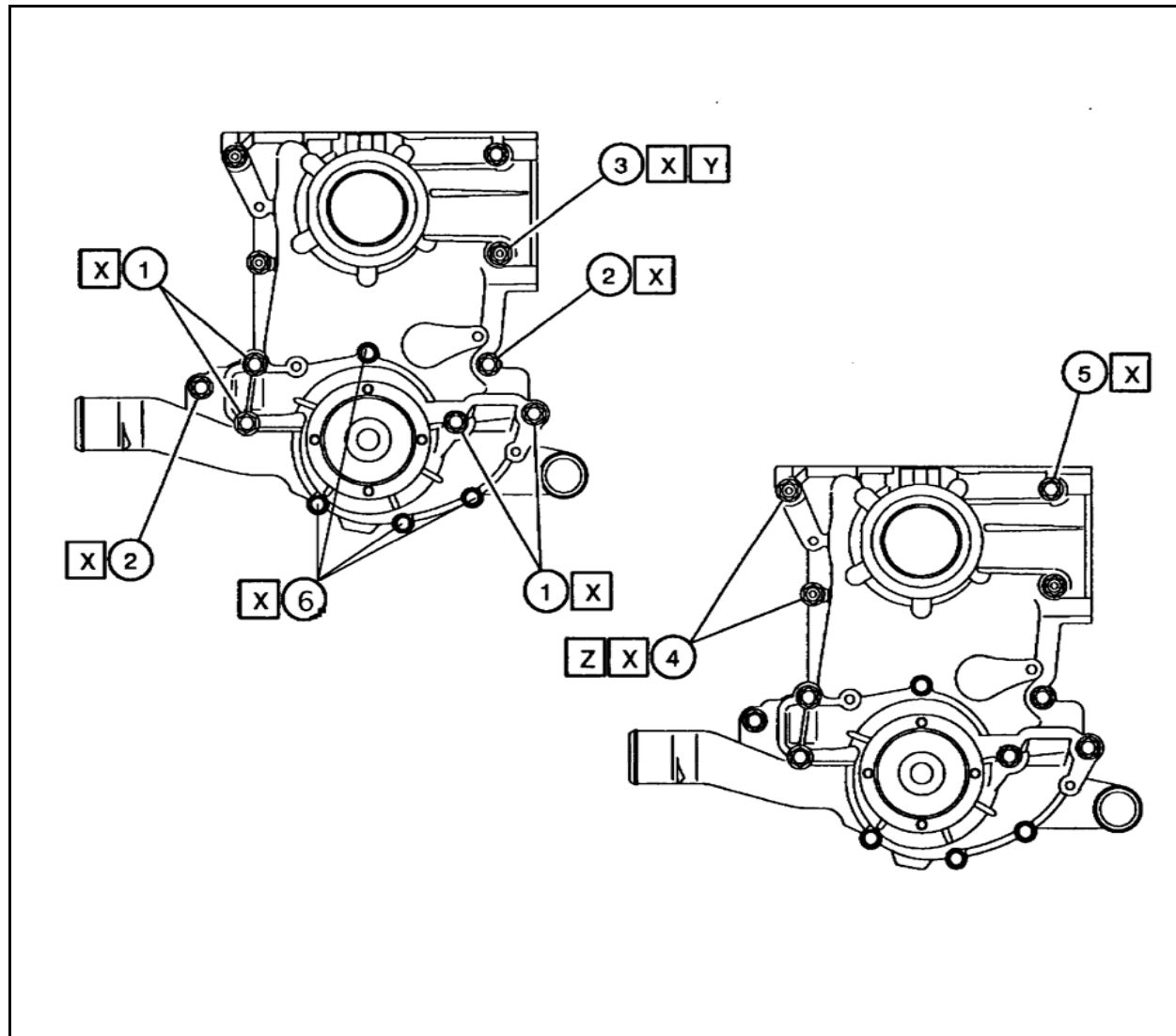
Specification	
1	OHT3F-031-3 Bolts included on print
2	24501565 Gasket
3	O-Ring 3F-031-2

REV	Date	Revision History
1	01/05/98	Block-30
2	12/01/99	Add thermocouple information
3	06/30/06	Update view, add gasket and O-ring part numbers

View	
Front Cover	
Front cover install	

<b>Front Cover, Rear Cover, &amp; Sump</b>	<b>Sequence III F</b>
--	-----------------------

Section	Sheet
4	7



Description of Operation	
X	Torque 30Nm
Y	Stud also holds crankshaft sensor shield
Z	Studs also hold crankshaft sensor shield and sensor

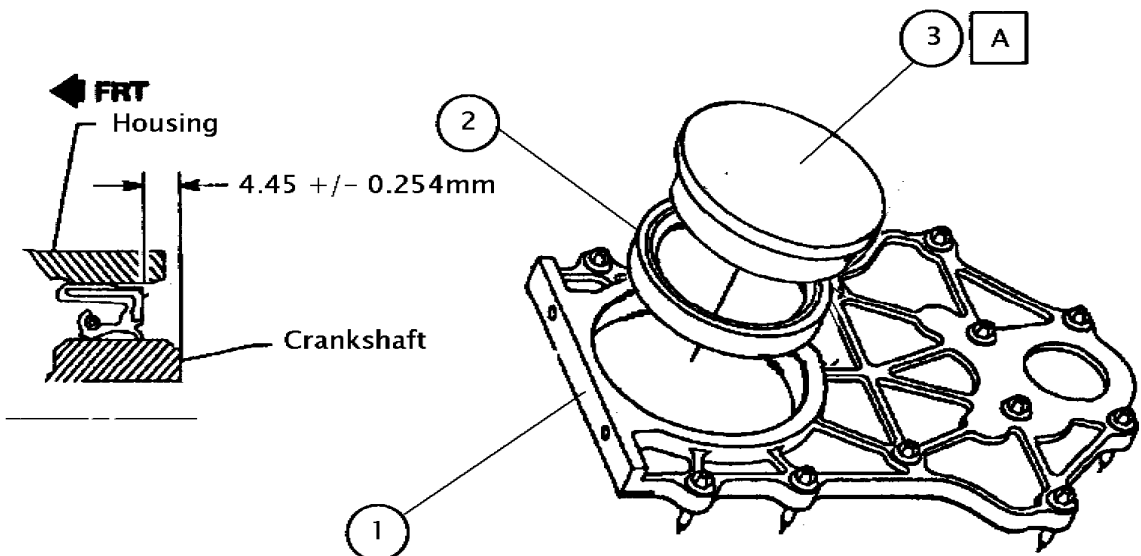
Specification	
1	5/16-18x3.5 (3) plus 3F031-03 Stud (1)
2	24504713 Bolt (2)
3	24504718 Stud (2)
4	24504717 Stud (2)
5	24504712 Bolt
6	1/4-20x1.75

REV	Date	Revision History
1	01/05/98	Block-28
2	06/30/06	Update items 1 & 6 fastener information

View	
Front Cover	
Front cover bolt placement	

<b>Front Cover, Rear Cover, &amp; Sump</b>	<b>Sequence IIIF</b>
--	----------------------

Section	Sheet
4	8



**Description of Operation**

A Install rear main lip seal using GM R&D supplied installation tool and or Kent-more J38196 and a light duty bench press until seal bottoms in housing.

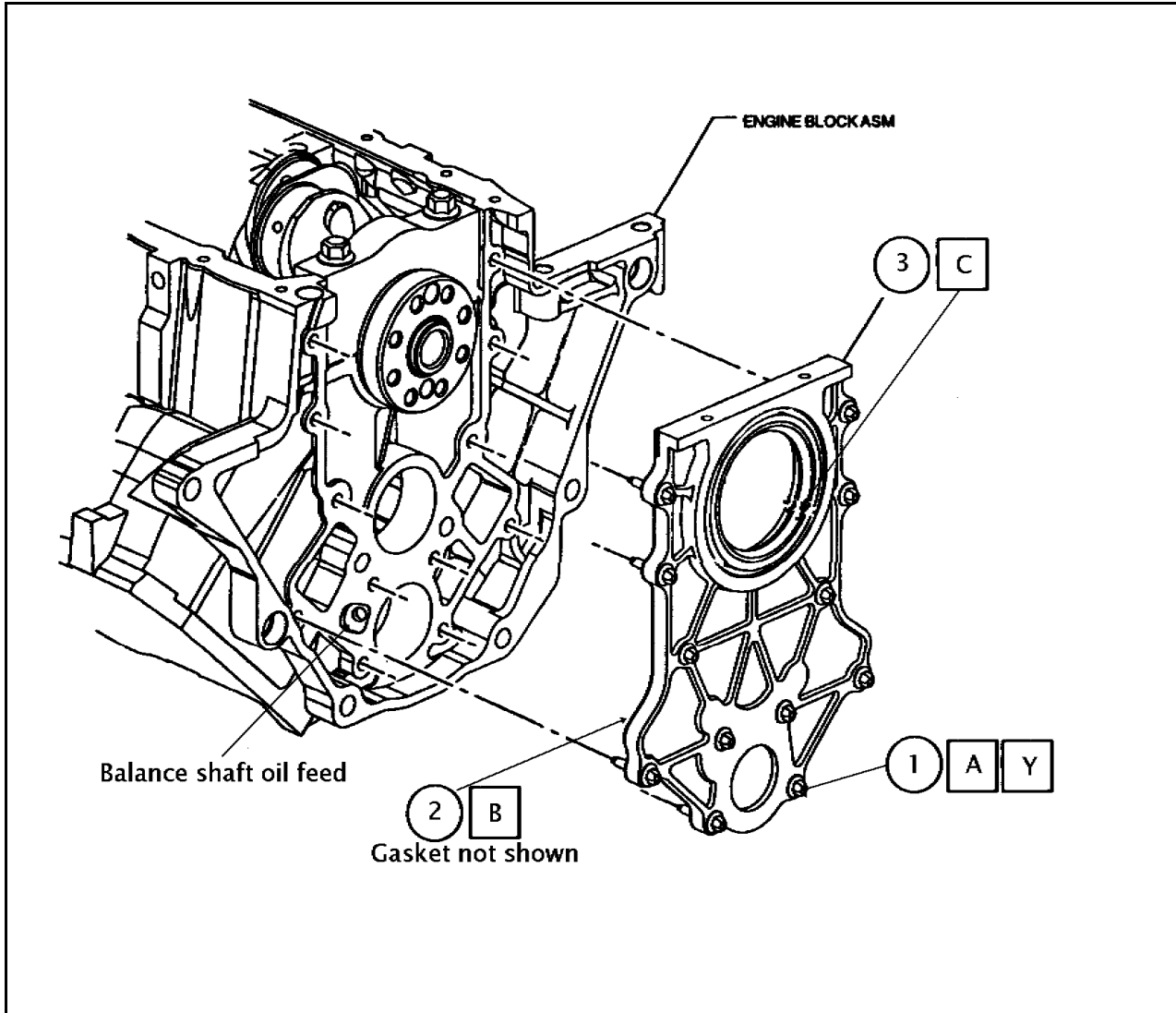
**Specification**

- 1 OHT3G-088-1Rear cover housing
- 2 OHT3G-091-1 Seal
- 3 GM R&D Seal Installation Tool or Kent-more J38196

REV	Date	Revision History
1	01/05/98	Block-31
2	11/03/04	Change rear seal part number to OHT3G-091-1
3	02/05/06	Change to OHT Rear Cover
4	03/05/10	Added Kent-more J38196 tool

View
<b>Rear Cover</b>
Rear seal installation

<b>Front Cover, Rear Cover, &amp; Sump</b>	<b>Sequence IIIF</b>	<b>Section</b>	<b>Sheet</b>
		4	9



Description of Operation	
A	Bolts may be run for as long as they remain serviceable.
B	Install gasket (not shown in view) <b>Note: Position rear cover plate gasket so that rear balance shaft oil feed is lined up with correct side of cover plate.</b>
C	Lubricate rear lip seal with EF-411 and use extreme care not to damage rear lip seal during rear cover plate installation.
Y	Torque & Angle 15Nm + 50°  Note: Perfect Seal #4 sealer may be used around coolant passages on gasket.

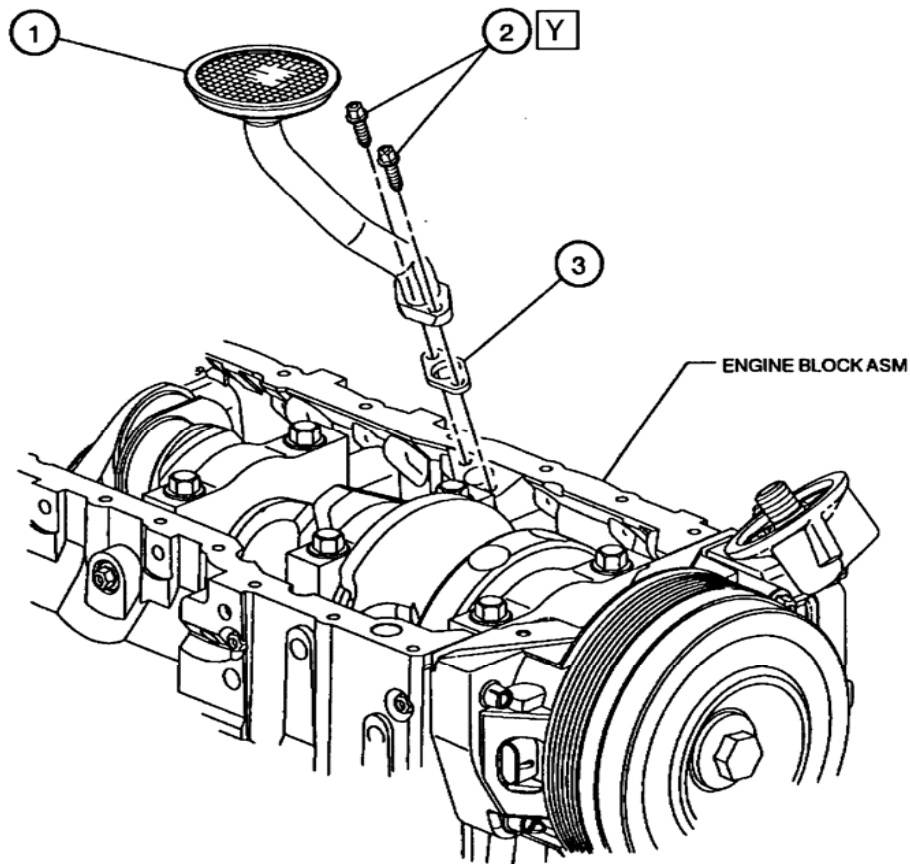
Specification	
1	24503970 Bolt
2	24507388 Gasket
3	OHT3G-088-1Rear cover housing

REV	Date	Revision History
1	01/05/98	Block-32
2	12/01/99	Add Perfect seal note.
3	02/05/06	Change to OHT Rear Cover w/24507388 gasket
4	07/20/06	Update fastener usage (remove nylon collar)
5	03/05/10	Update fastener usage (allowed use for multiple tests)

View	
<b>Rear Cover</b>	
Rear cover installation	

<b>Front Cover, Rear Cover, &amp; Sump</b>	<b>Sequence III F</b>
--	-----------------------

Section	Sheet
4	10



**Description of Operation**

Install oil screen assembly

Y Torque 15Nm

**Specification**

- 1 24505569 Screen assembly
- 2 24505570 Bolt
- 3 12581570 Gasket

REV	Date	Revision History
1	01/05/98	Block-33
2	02/01/06	Change gskt. From 24501259 to 12581570

**View**  
**Sump**

Oil pickup tube

**Section**

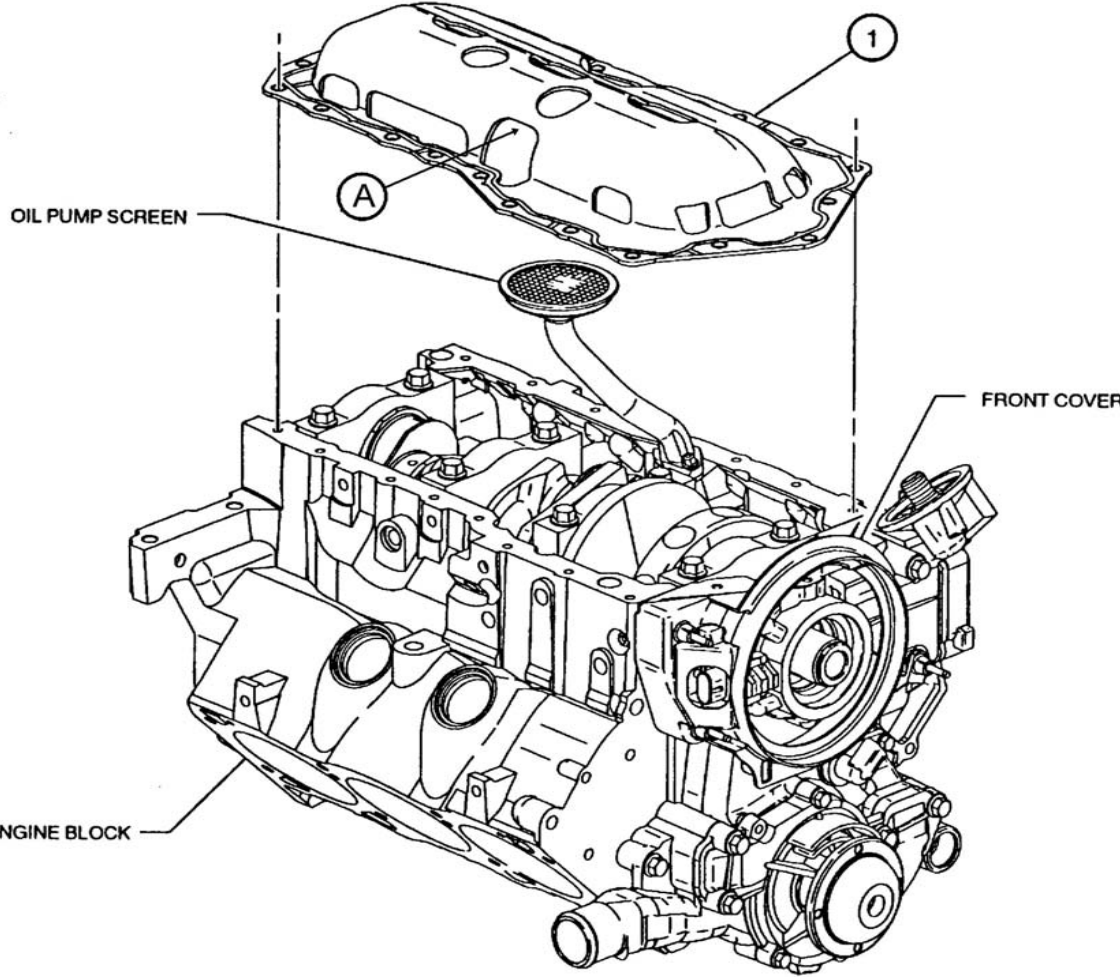
**Sheet**

4

11

**Front Cover, Rear Cover, & Sump**

**Sequence III F**



**Description of Operation**

Install oil pan gasket

A Insure that calibrated oil level dipstick clears windage tray before final assembly

Note: RTV, GM, (see part number info) or Dow Corning 3154 may be used at corners of front and rear covers to aid in sealing.

GM Silicone Sealer  
 New numbers:  
 12346141 Tube  
 12551715 Cartridge

Old numbers: (Still acceptable for test)  
 12346192 Tube  
 12346193 Cartridge

**Specification**

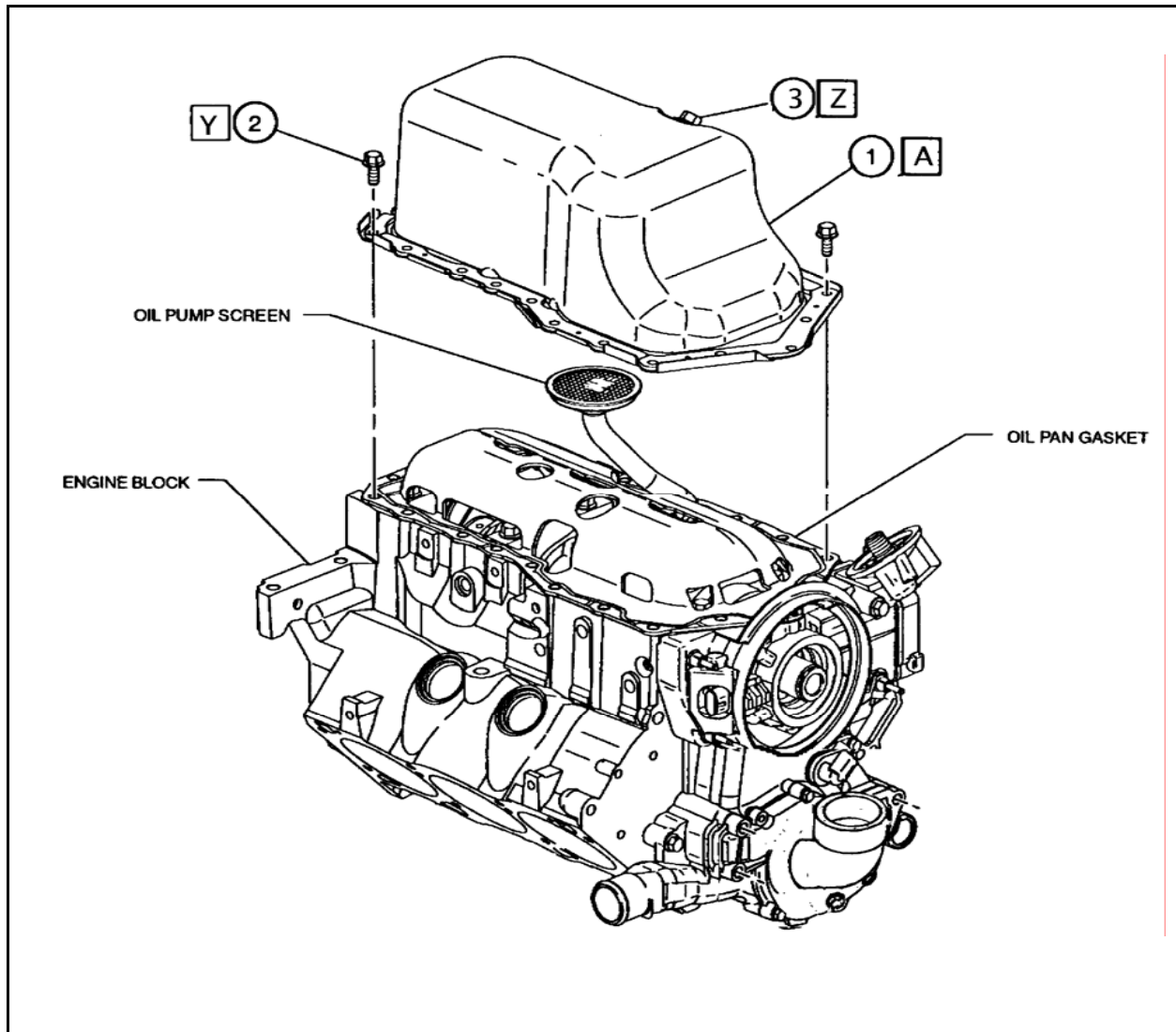
1	OHT3G-093-1 Gasket
---	--------------------

REV	Date	Revision History
1	01/05/98	Block-34
2	4/28/03	Change part number from 24502397 to 12574776
3	12/15/03	Add approved silicone sealers
4	03/15/04	Update Sealer information
5	11/03/04	Change oil pan gasket to OHT3G-093-1

<b>Front Cover, Rear Cover, &amp; Sump</b>	<b>Sequence III F</b>
--	-----------------------

View	
Sump	
Oil pan gasket install	
Section	Sheet
4	12



Description of Operation	
A	Install oil pan
Y	Torque 14Nm
Z	Oil drain plug to be thermocoupled

Specification	
1	Oil pan OHT3F-073-1
2	24502791 or 11610052 Bolt
3	OHT3F-063-1 Modified drain plug

REV	Date	Revision History
1	01/05/98	Block-35
2	02/05/06	Add 11610052 Bolt

View
Sump
Oil pan installation

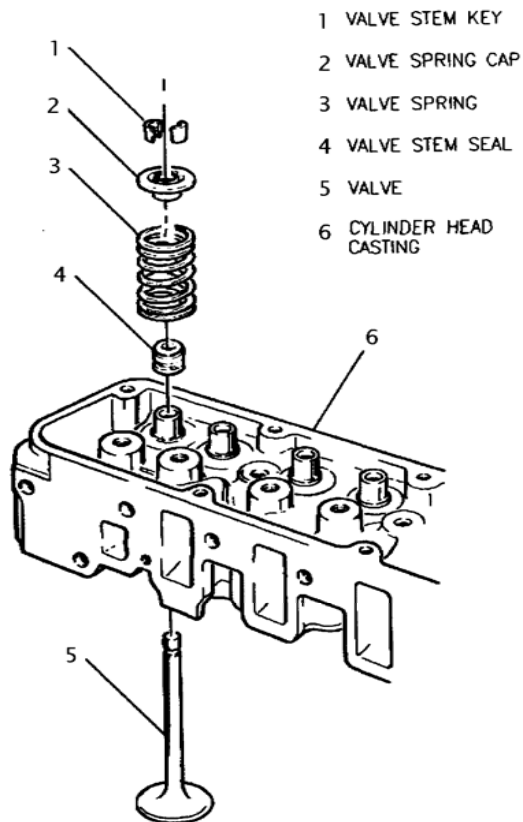
Front Cover, Rear Cover, & Sump	Sequence IIIF
---------------------------------	---------------

Section	Sheet
4	13

## **Section 5**

### **Cylinder Head and Valves**





- 1 VALVE STEM KEY
- 2 VALVE SPRING CAP
- 3 VALVE SPRING
- 4 VALVE STEM SEAL
- 5 VALVE
- 6 CYLINDER HEAD CASTING

During calibration, use OHT3F-070-1 Sleeve to protect seals from being cut and OHT3F-072, 006", 010", 015", & 020" shims to assist in obtaining proper load.

**Description of Operation**

Clean cylinder head by automated parts washer (see section 1 sheet 5A) or with degreasing solvent and spray with 50/50 solution of EF-411 and degreasing solvent. Remove excess solution using compressed air.

Lubricate valve stems and guides with EF-411 during assembly. Ensure valve stem moves freely in guide before installing valve seal. Use a protective sheath over the valve stem that extends downward past the keeper grooves when installing the valve stem seals.

Install the valve springs, retainers, and keepers.

Calibrate the valve spring load to 801N +/- 22N @ 9.5mm (180lbf +/- 5lbf @ 0.375in.) travel.

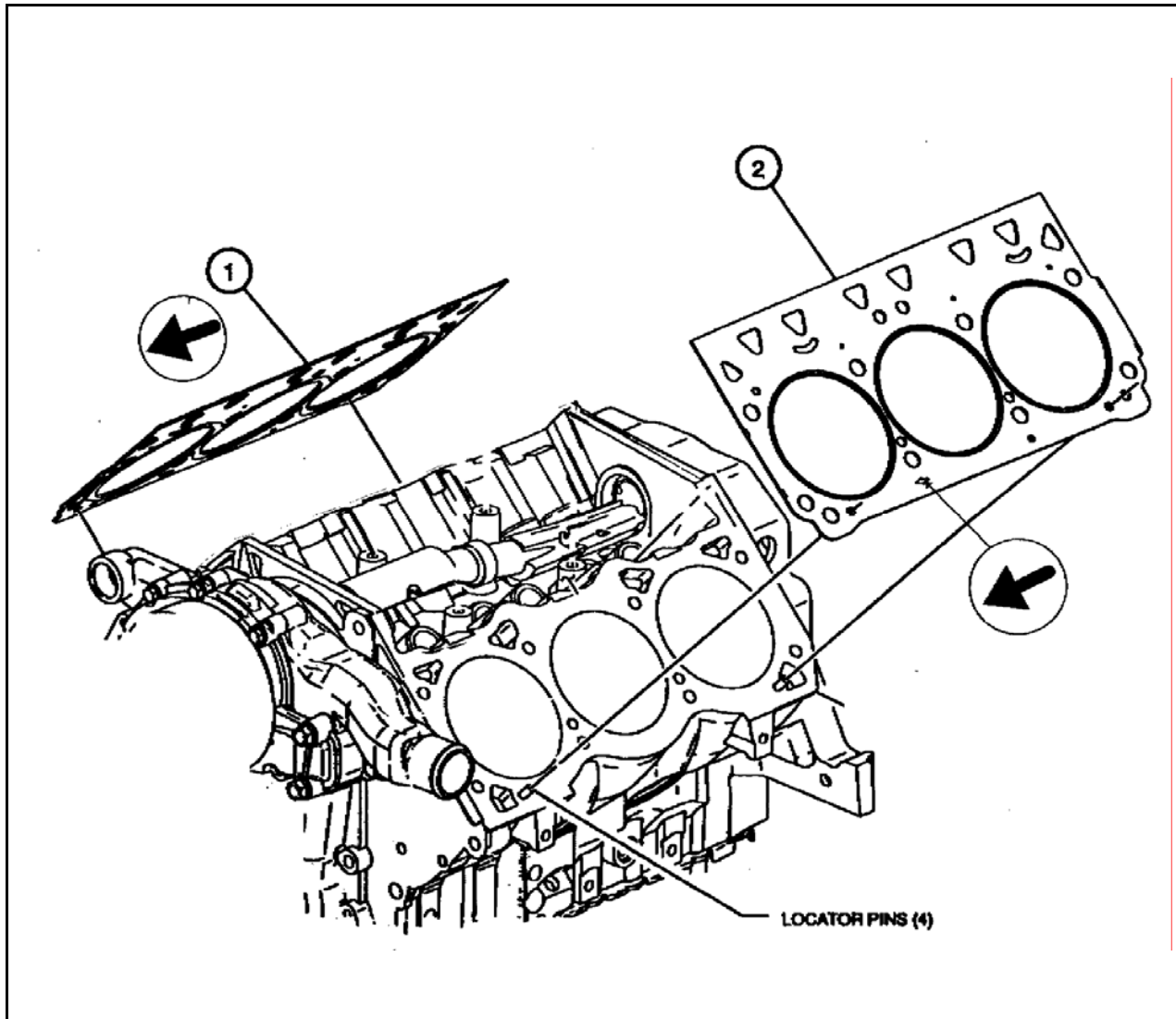
**Specification**

- 1 10166345 Valve stem key
- 2 24502257 Valve spring cap
- 3 OHT3F-059-5 Valve spring (Yellow)
- 4 OHT3F-060-1 Seal int.  
OHT3F-061-1 Seal exh. White stripe
- 5 12569550 Valve Int. (STD)  
12579949 Valve Exh.(STD)
- 6 24502260 Head, GM Raceshop

REV	Date	Revision History
1	01/06/98	Block-36
2	9/9/03	Change calibration from +/- 5lbf to +/- 10lbf
3	12/15/03	Update, change to mineral spirits
4	11/03/04	Change part number for exhaust valve from 24507423 to 12579949
5	06/30/06	Change intake part number from 24502254 to 12569550 and cleaning procedure update

<b>Head Assembly</b>	<b>Sequence III F</b>
----------------------	-----------------------

View	
Head Assembly	
Valve & spring assembly	
Section	Sheet
5	1



**Description of Operation**

Head gaskets are not interchangeable. Installing the head gasket with the arrow pointing to the rear will cause gasket failure and possible engine failure.

Install the head gasket with the arrow pointing toward the front of the engine.

Do not use any sealers on the head gaskets.

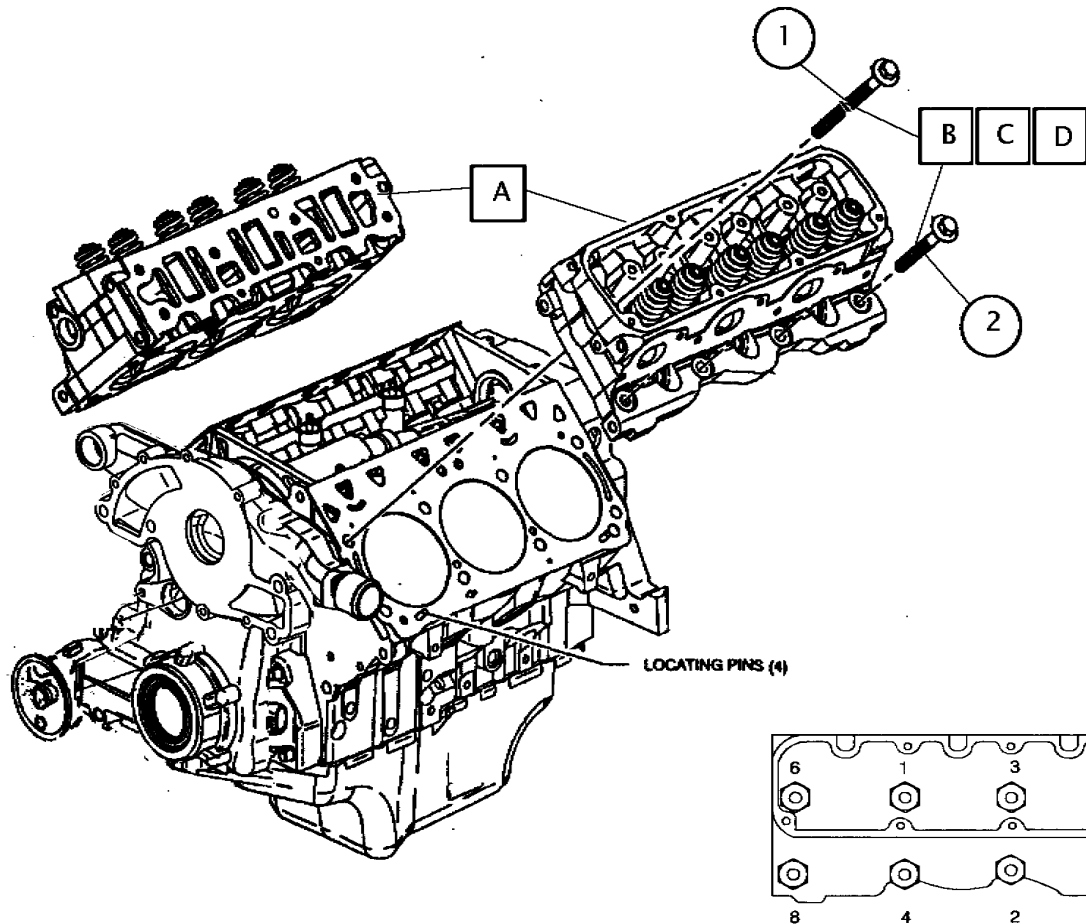
Specification		
1	24503801	Gasket RH
2	24503802	Gasket LH

REV	Date	Revision History
1	01/06/98	Block-37

View
<b>Head Gaskets</b>
Head gasket install

<b>Head Assembly</b>	<b>Sequence III F</b>
----------------------	-----------------------

Section	Sheet
5	2



**Description of Operation**

- A Carefully install cylinder heads.
- B Clean all sealer from new bolt threads and underside of head.
- C Install #2 Permatex on threads and underside of fastener head.
- D Torque fasteners from center out using a crisscross pattern.  
30Nm-50Nm-80Nm-145±7Nm

**Specification**

- 1 25527831 Bolt Cyl. Head (8) Long
- 2 88891770 Bolt Cyl. Head (8) Short  
25533811K (Old)

**View**

**Cylinder Head**

Cylinder head installation

**Section**

5

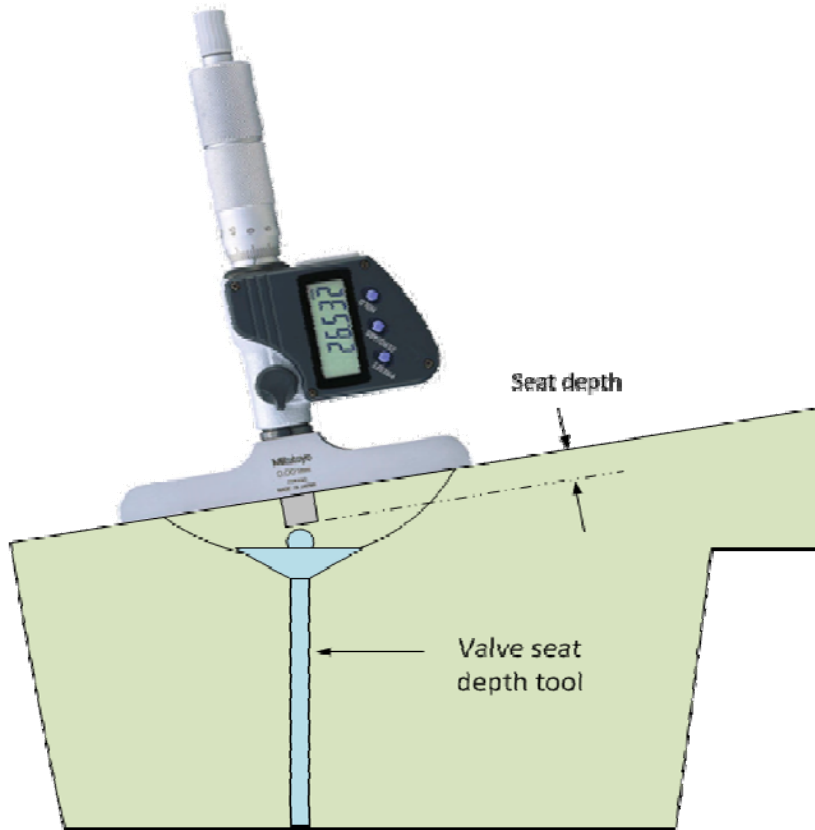
**Sheet**

3

REV	Date	Revision History
1	01/06/98	Block-38 & 50
2	07/20/06	Update part number, change 25533811 to 88891770
3	03/30/07	Update fastener torquing procedure to 30Nm-50Nm-80Nm-145±7Nm final torque
4	03/05/10	Corrected short head bolt number
<b>Head Assembly</b>		<b>Sequence III F</b>

## **Section 5a**

**Cylinder Head Part Number 24502260S and Valves**



**Description of Operation**

Prior to use, determine baseline for valve recession by measuring the seat depth using a valve with a 0.321 diameter ball afixed to the center of the valve. Remove a minimum of 1/2 inch of the valve stem to preclude valve stem from pertruding beyond the top of the guide.

Measure the baseline valve set depth to the nearest thousandth (0.001) inch using a Mitutoyo model 329-711-10 or 329-350-10 depth micrometer.

**Specification**

1 24502260S Head, GM Raceshop

**View**

**Head Assembly**

Initial Measurements

**Section**

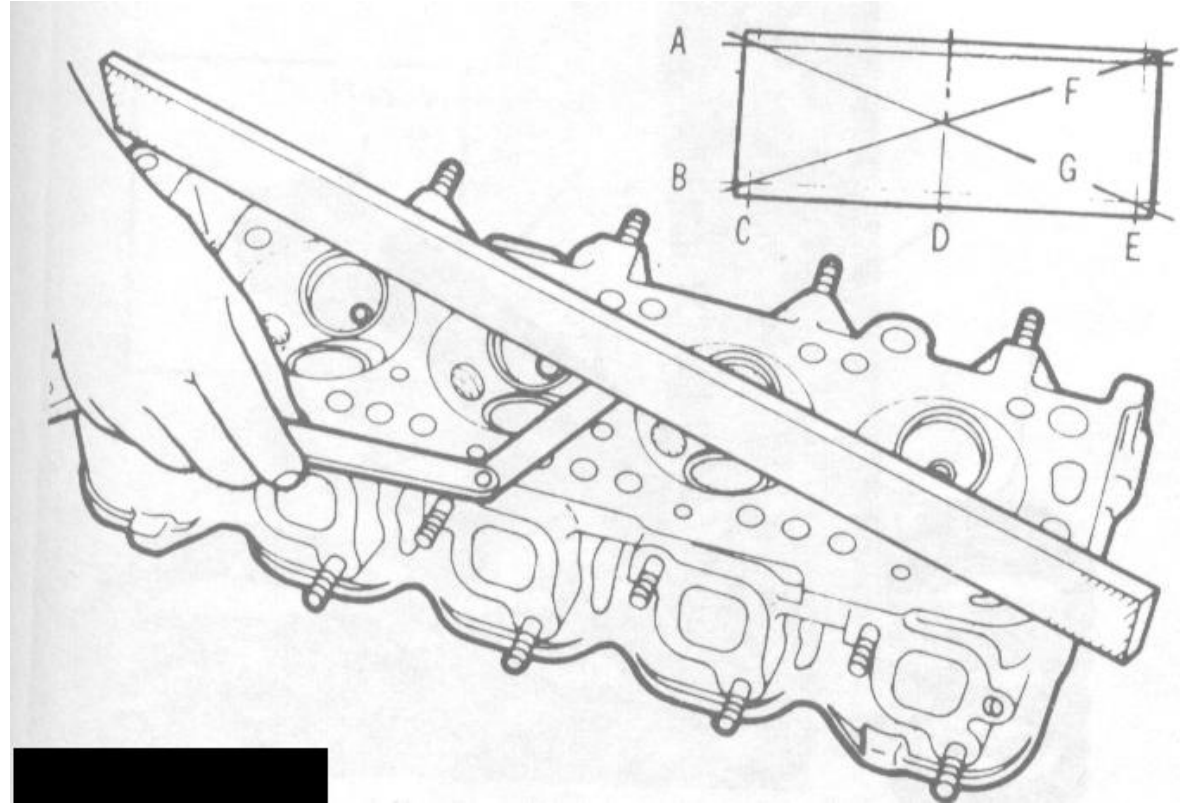
5a

**Sheet**

1

REV	Date	Revision History
Head Assembly		Sequence IIIF

			<b>Description of Operation</b>	
			<p>When reusing cylinder head part number 240502260S, Clean cylinder head by automated parts washer or ultrasound bath and spray with 50/50 solution of EF-411 and degreasing solvent. Remove excess solution using compressed air. Do not use sandpaper, scotchbrite pads or other abrasives to clean heads.</p> <p>Visually inspect seats for wear. Measure Valve recession using procedure in 5a, sheet 1. Reject any heads where valve recession exceeds 0.005"</p> <p>Measure valve guide clearances at top and bottom of guides. Reject any heads which do not meet clearance of 0.0015 to 0.0032 inch.</p>	
			<b>Specification</b>	
<b>REV</b>	<b>Date</b>	<b>Revision History</b>	<b>View</b>	
			<b>Initial Prep, reusing Head 24052260S</b>	
<b>Head Assembly</b>		<b>Sequence IIIF</b>		<b>Section</b>
				5a
				<b>Sheet</b>
				2



**Description of Operation**

Remove any remaining gasket material from the deck surface. Do not use sandpaper, scotchbrite or other abrasives which could transfer to the head surface.

Using a straight edge, measure the clearance between the straight edge and the head with a feeler gauge. Maximum .004"

Spray head with degreasing solvent and dry with compressed air. Wash heads in power washer for 30 minutes, or use ultra sonic cleaner for 30 minutes to remove debris from combustion chamber and intake and exhaust ports.

Rinse with hot water and immediately spray with 50-50 mixture of degreasing solvent and EF411

**Specification**

**View**

**Initial Prep, reusing Head 24052260S**

**Section**

5a

**Sheet**

3

REV	Date	Revision History

**Head Assembly**

**Sequence III F**

			<b>Description of Operation</b>		
			<p>Lap valves using a water based valve grinding compound. Use Permatex Valve Grinding Compound, water mixed, item #80036.</p> <p>Thoroughly clean lapping compound from valves and seats using water and a lint free rag. Be sure all lapping compound is removed. After cleaning lapping compound, spray entire head with degreasing solvent. Spray with, with 50-50 mixture of degreasing solvent and EF411 then blow dry with compressed air.</p> <p>Apply bluing to each valve and install. Visually inspect for proper seating. The bluing ring should be a consistent width around the entire valve circumference and be positioned toward the middle of the face. If valves show proper seating appearance, repeat "Pre Test Measurement Procedure". If Valve seat wear does not exceed .005", heads are acceptable for re-use.</p>		
			<b>Specification</b>		
<b>REV</b>	<b>Date</b>	<b>Revision History</b>	<b>View</b>		
			<b>Head Preparations (continued)</b>		
<b>Head Assembly</b>		<b>Sequence IIIF</b>		<b>Section</b>	<b>Sheet</b>
				5a	4



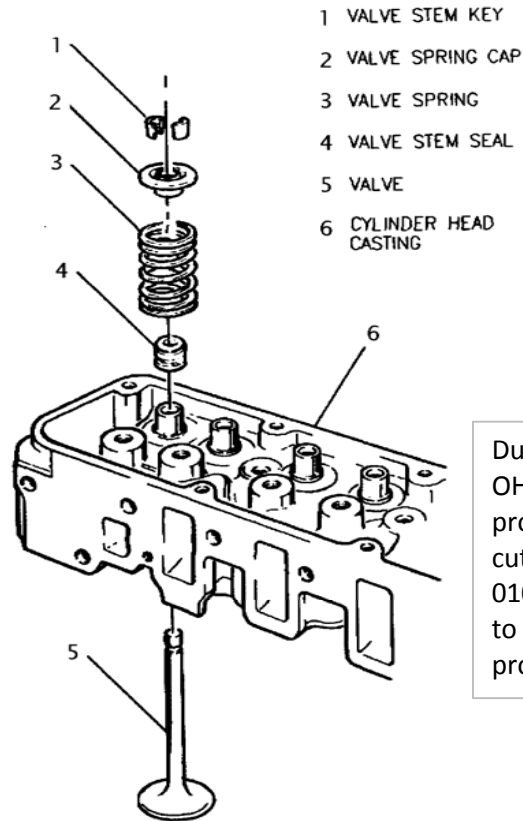
**Description of Operation**

Lubricate valve stems and guides with EF-411 during assembly. Ensure valve stem moves freely in guide before installing valve seal. Use a protective sheath over the valve stem that extends downward past the keeper grooves when installing valve stem seals.

Install the valve springs, retainers and keepers.

Calibrate the valve spring load to 801 N  $\pm$  22N @ 9.5 mm (180lbf  $\pm$  5lbf @ 0.375 in.) travel.

Apply a vacuum source to the heads and verify that a minimum of 24in. Hg can be obtained.



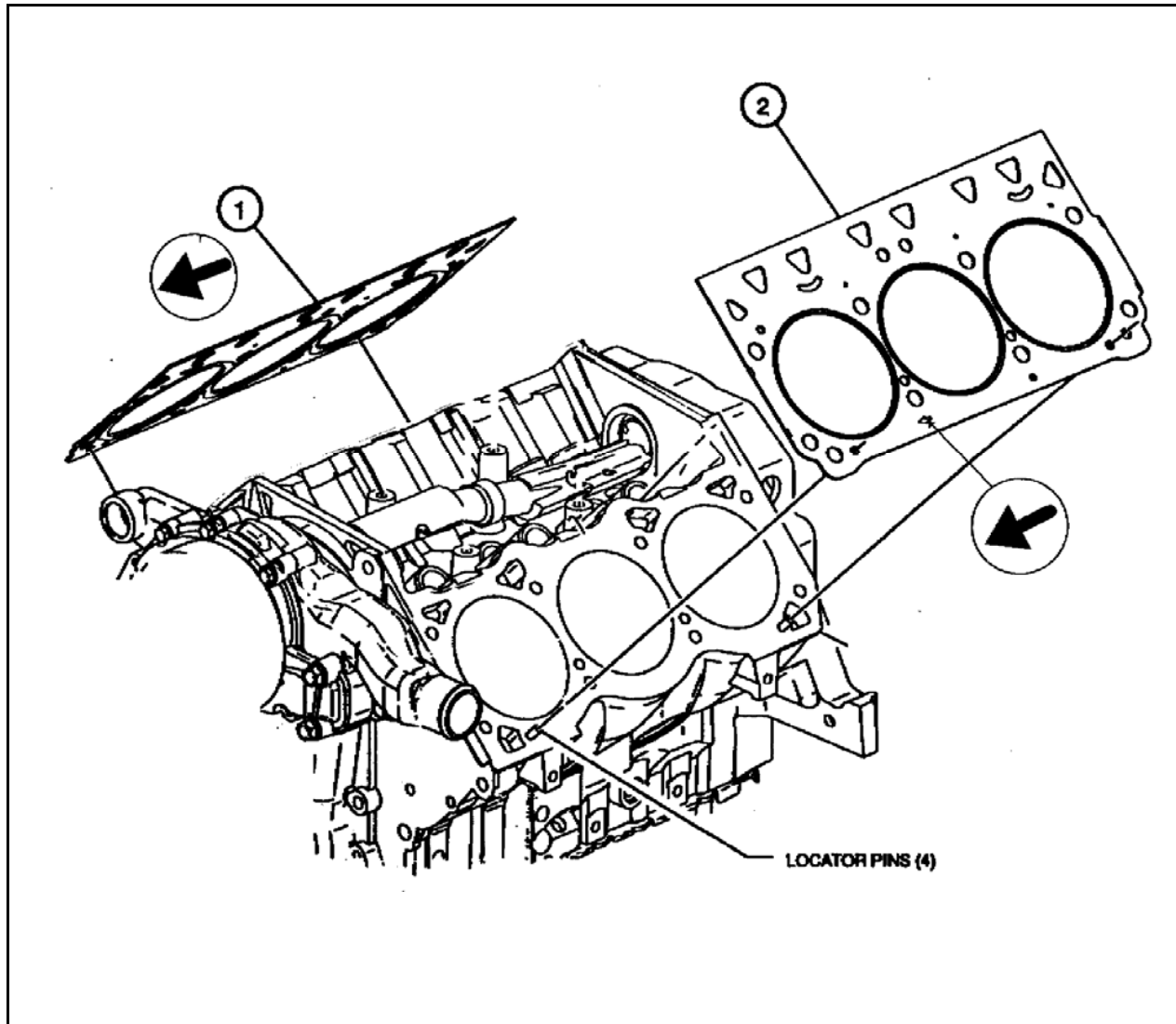
During calibration, use OHT3F-70-1 Sleeve to protect seals from being cut and OHT3F-072, 060", 010", 015" & 020" shims to assist in obtaining proper load.

**Specification**

- 1 10166345 Valve stem key
- 2 24502257 Valve spring cap
- 3 OHT3G-059-5 Valve spring (Yellow)
- 4 OHT3F-060-1 Seal intake  
OHT3F-061-1 Seal exh (White stripe)
- 5 12569550 Valve, Intake (STD)  
12579949 Valve, Exhaust (STD)
- 6 24502260S Head, GM Raceshop

REV	Date	Revision History
Head Assembly		Sequence IIIF

View	
Valve and spring assembly	
Section	Sheet
5a	5



**Description of Operation**

Head gaskets are not interchangeable.

Installing the head gasket with the arrow pointing to the rear will cause gasket failure and possible engine failure.

Install the head gasket with the arrow pointing towards the front of the engine.

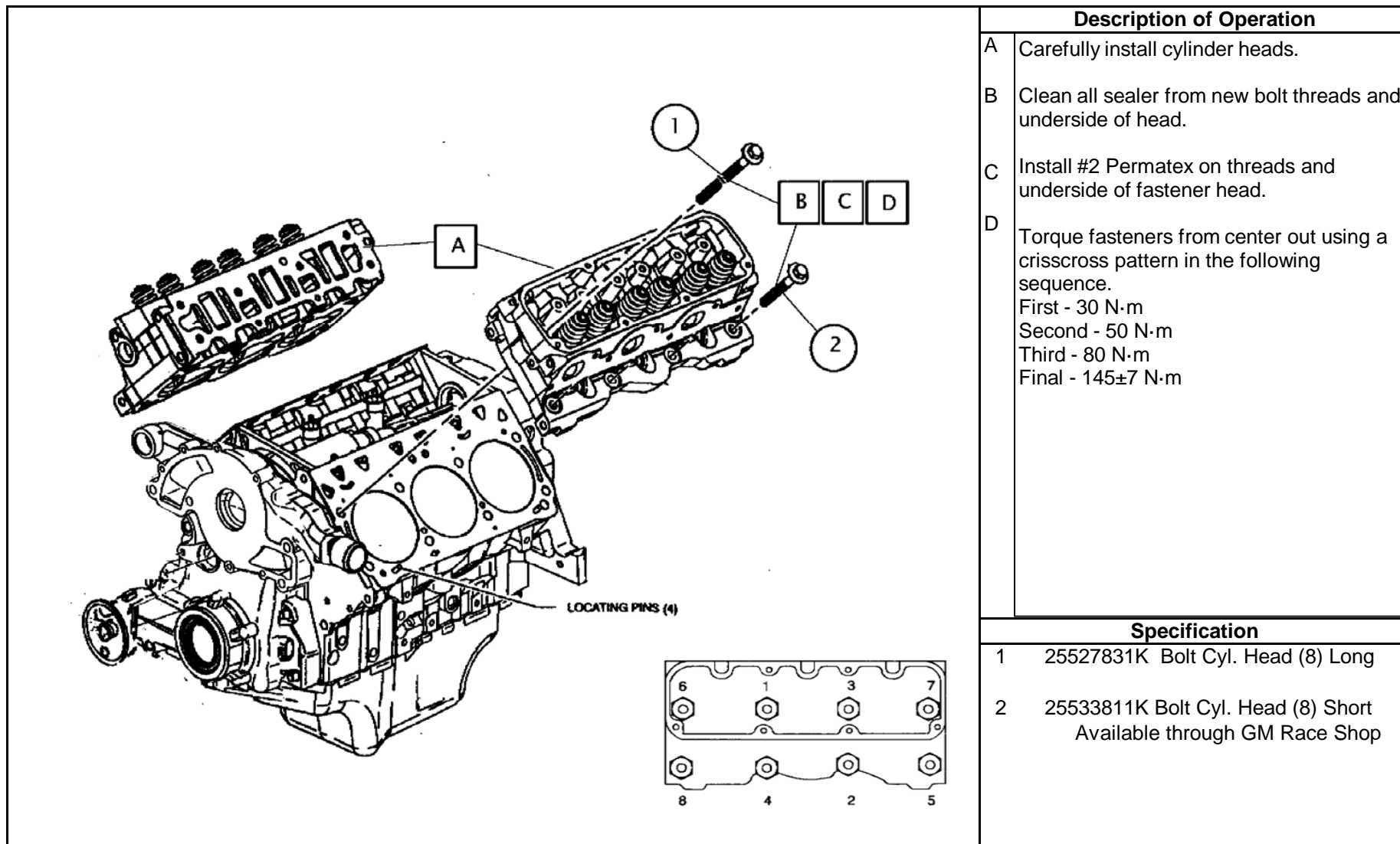
Do not use any sealers on the head gaskets.

**Specification**

- 1 24503801 Gasket RH
- 2 24503802 Gasket LH

REV	Date	Revision History
Head Assembly		Sequence III F

View	
Section	Sheet
5a	6



REV	Date	Revision History
Head Assembly		Sequence III F

Description of Operation	
A	Carefully install cylinder heads.
B	Clean all sealer from new bolt threads and underside of head.
C	Install #2 Permatex on threads and underside of fastener head.
D	Torque fasteners from center out using a crisscross pattern in the following sequence. First - 30 N·m Second - 50 N·m Third - 80 N·m Final - 145±7 N·m

Specification	
1	25527831K Bolt Cyl. Head (8) Long
2	25533811K Bolt Cyl. Head (8) Short Available through GM Race Shop

View	
Cylinder Head	
Cylinder head installation	
Section	Sheet
5a	7

## **Section 6**

### **Long Block Assembly**

**Description of Operation**

A Measure and record pre-test lifter foot height to the nearest 0.001mm

B Installation:

- 1) Clean each lifter using a lightly soaked cloth with clean (new) degreasing solvent (Do not disassemble, spray, or submerge the lifter in solvent). Dry each lifter foot using a clean dry cloth or terry towel.
- 2) Useig 118ml (4 oz.) of test oil, dip each lifter foot in test oil and install the lifter set less pushrods.
- 3) Rotate engine crankshaft 720° slowly with no load on lifters.
- 4) Remove each lifter, one at a time, and again dip each foot in test oil and re-install with the ground flat facing inboard.
- 5) With the oil pan on the engine, pour the remainder of the 118ml in the valley.

**Specification**

1 OHT3f-029-3 ACI Test Lifter (with flats )

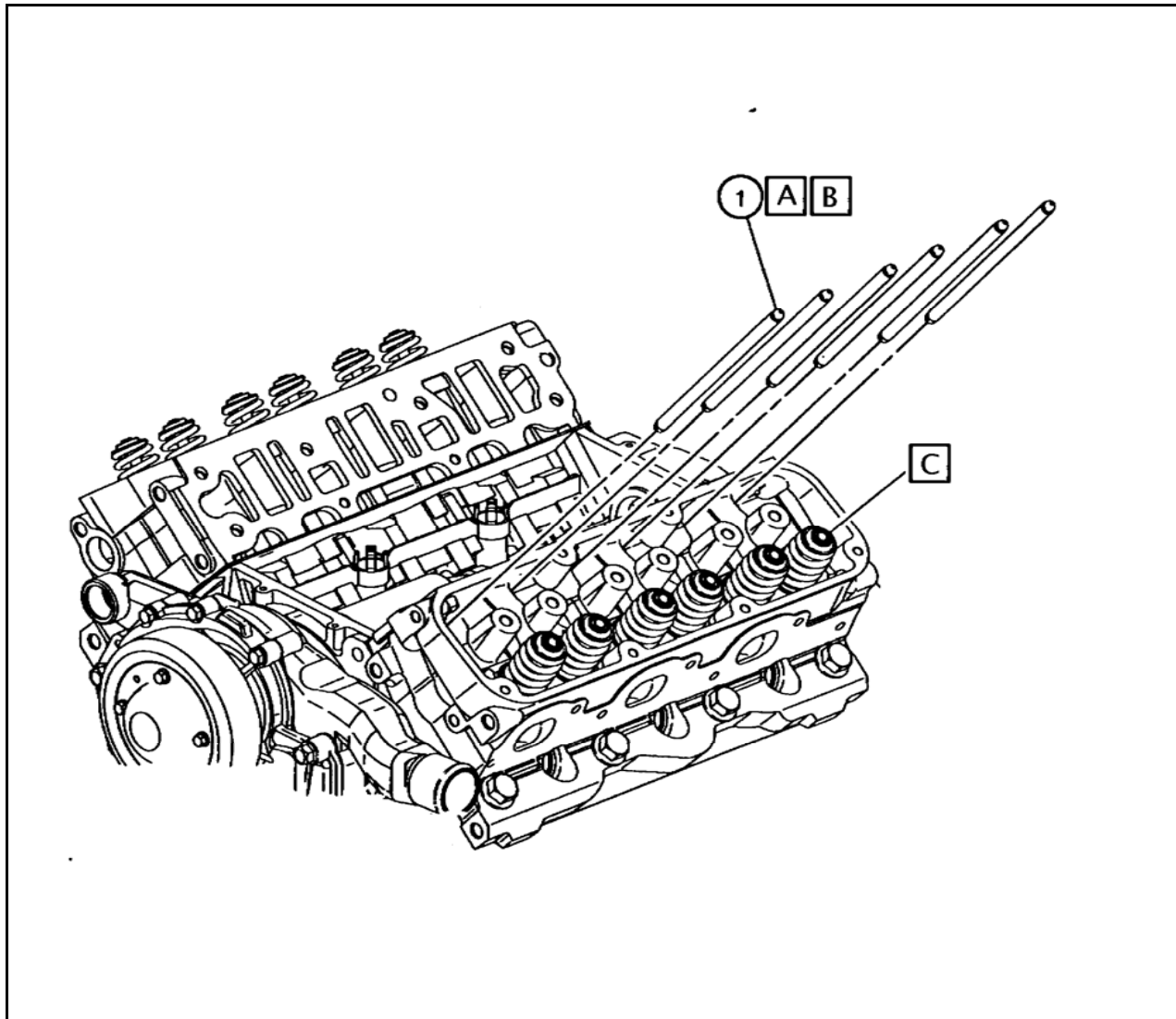
REV	Date	Revision History
1	1/6/1998	Block-39
2	12/15/03	Update, change to mineral spirits
3	7/20/06	Update operation and change to degreasing solvent

View	
<b>Lifter Installation</b>	
Lifter pre-oiling and installation	

**Long Block Assembly**

**Sequence III F**

Section	Sheet
6	1



Description of Operation	
A	Clean all pushrods with clean lint free towel and degreasing solvent and spray with a 50/50 solution of EF-411 and degreasing solvent. Remove excess with compressed air. Lubricate each pushrod end, pushrod seat, and rocker arm ball socket with EF-411 prior to installation.
B	Install pushrods
C	Lubricate each valve stem seal and tip with EF-411.

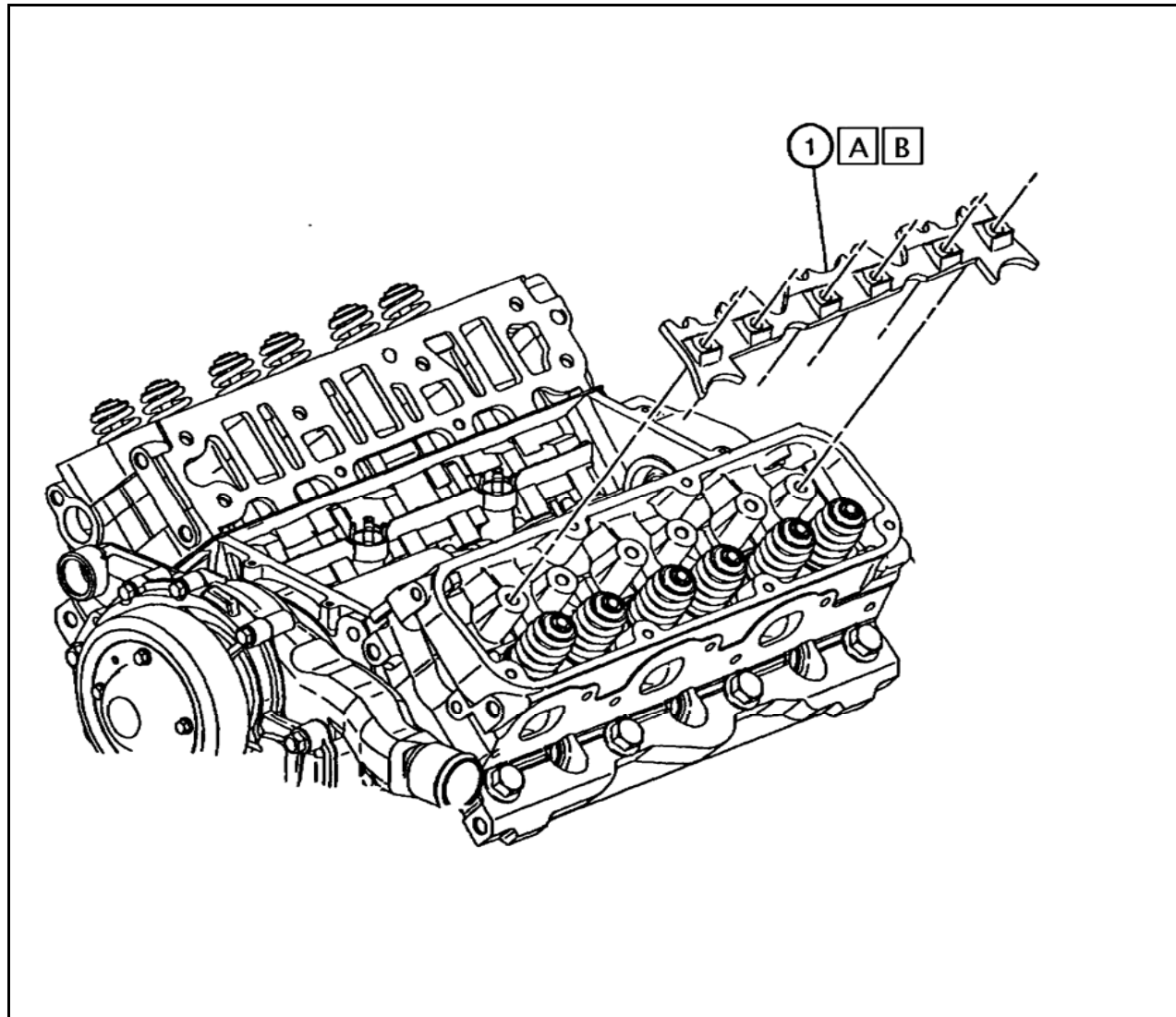
Specification	
1	OHT3F-007-1 Pushrod (Special Length)

REV	Date	Revision History
1	1/6/1998	Block-40
2	12/15/03	Update, change to mineral spirits
3	7/20/06	Update change to degreasing solvent and clean towel for cleaning

View	
Pushrods	
Pushrod installation	

<b>Long Block Assembly</b>	<b>Sequence III F</b>
----------------------------	-----------------------

Section	Sheet
6	2



Description of Operation	
A	Clean and inspect for wear. (Replace Retainer after 6 tests)
B	Install pushrod guide / rocker bearing retainer.

Specification	
1	24502278 Retainer

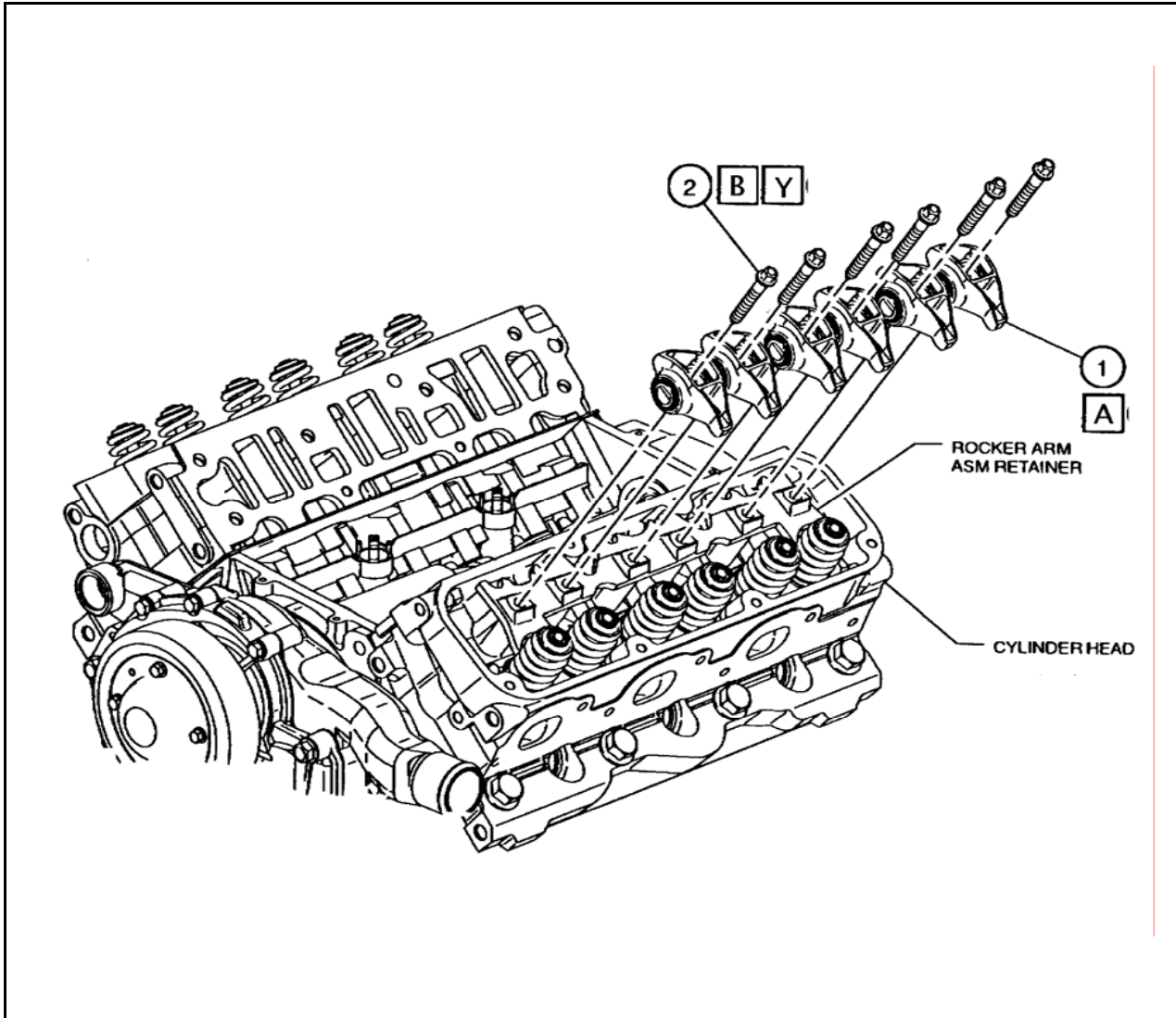
REV	Date	Revision History
1	1/6/1998	Block-41
2	7/20/06	Update usage, replace after 6 tests

View
Retainer
Rocker bearing retainer installation

**Long Block Assembly**

**Sequence III F**

Section	Sheet
6	3



Description of Operation	
A	Lubricate rocker arms with EF-411 and install. <b>Note: Rocker arm assemblies are replaced every test. Do not dip or spray with degreasing solvent. Needle roller bearings will retain solvents.</b>
B	Lubricate bolts with EF-411 and install.
Y	Torque & Angle 25Nm + 70°  Note: Do not rotate engine after final valvetrain loading.

Specification	
1	OHT3F-058-1 Rocker Arm Assembly
2	Furnished less sealers with OHT Kit

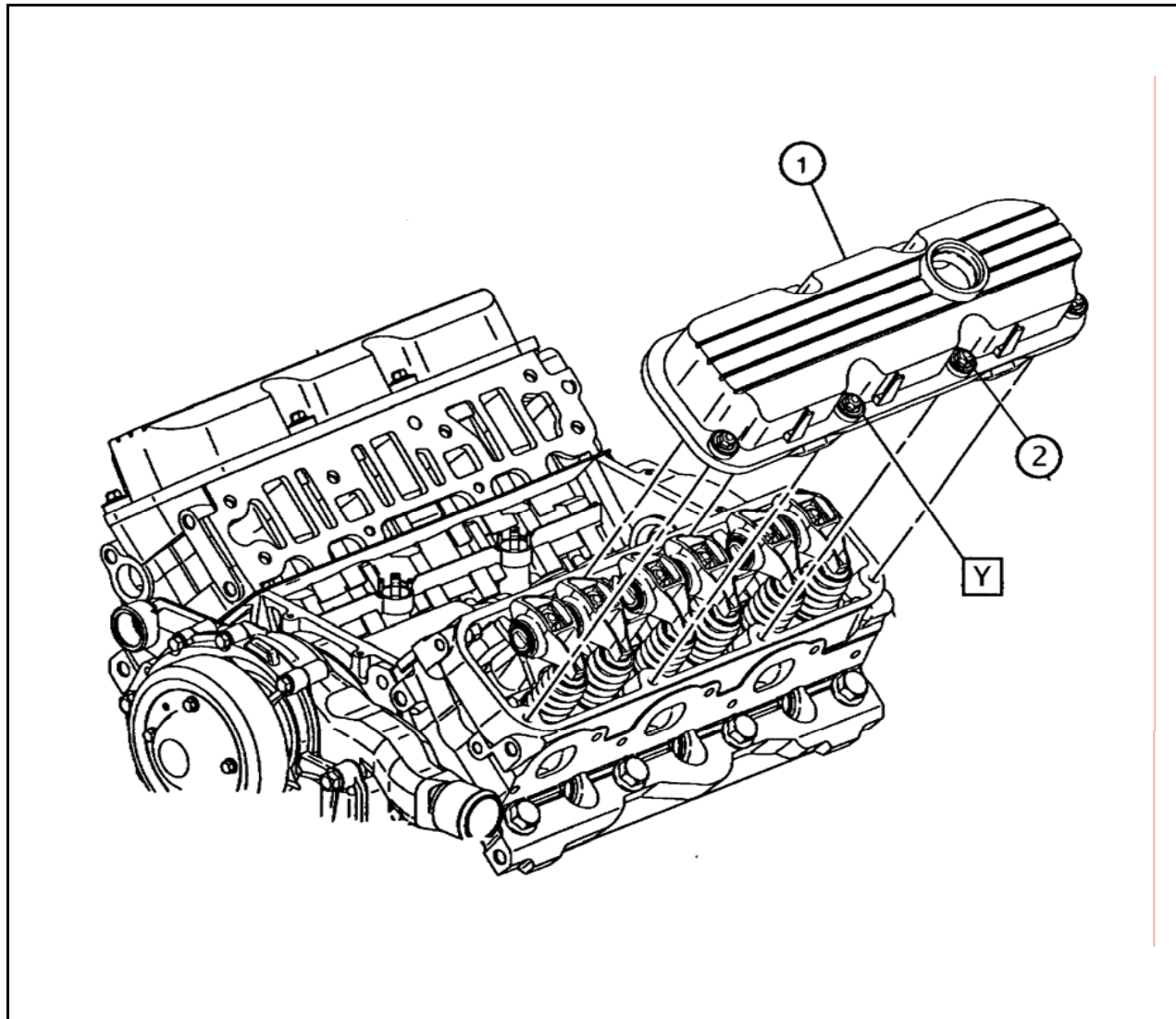
REV	Date	Revision History
1	1/6/1998	Block-42
2	12/15/03	Update, change to mineral spirits
3	7/20/06	Update, change to degreasing solvent

View	
Rocker Arm	
Rocker arm installation	

<b>Long Block Assembly</b>	<b>Sequence III F</b>
----------------------------	-----------------------

Section	Sheet
6	4





Description of Operation	
	Install rocker covers
Y	Torque 10Nm

Specification	
1	12590366 Cover, Valve Lt (2)
2	24502164 Bolt 25534748 Bolt w/washer
3	25532619 Gasket (Not Shown)

REV	Date	Revision History
1	1/6/1998	Block-43
2	3/30/07	Update Rocker Cover part number new 12590366 old 25534751

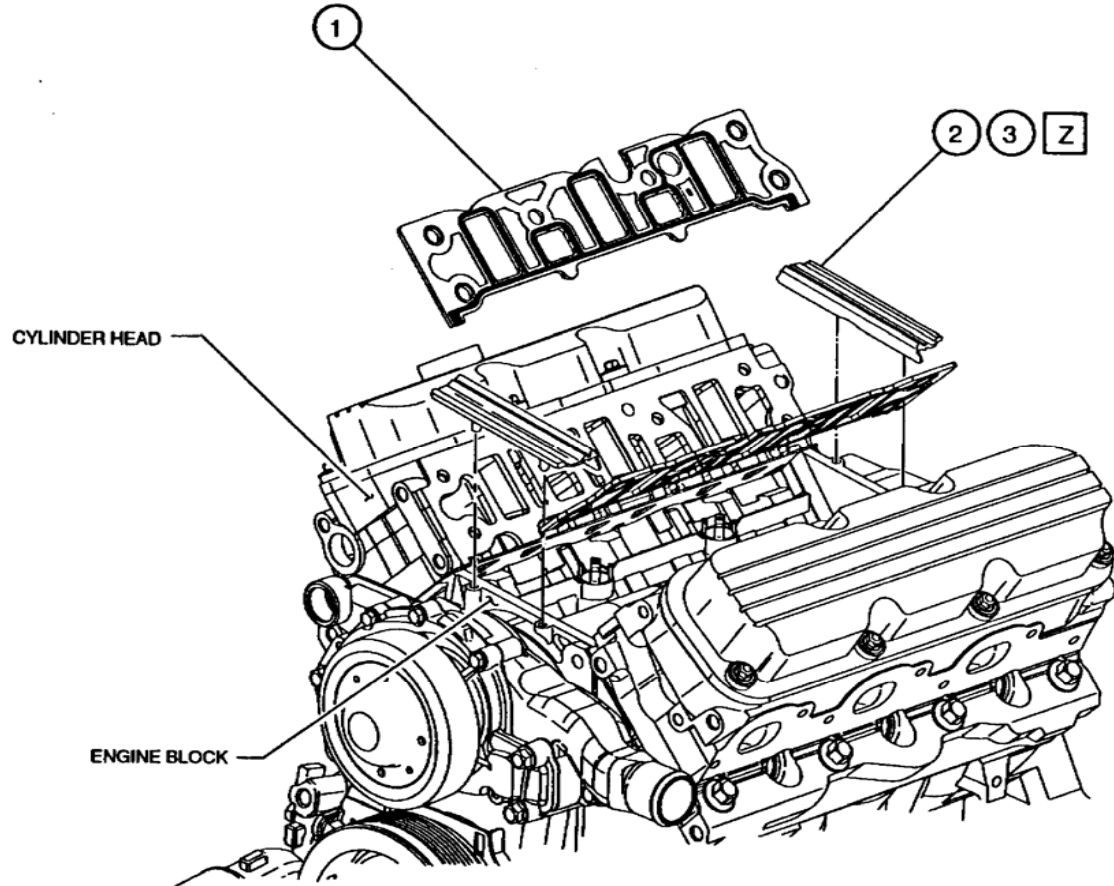
View
<b>Rocker Cover</b>
Rocker cover installation

**Long Block Assembly**

**Sequence III F**

**Section**  
6

**Sheet**  
5



**Description of Operation**

2nd design gasket kit uses locating pins for front and rear seals

Z Apply RTV, GM (see part number info) or Dow Corning 3154 sealer to both ends.

GM Silicone Sealer

New numbers:

12346141 Tube

12551715 Cartridge

Old numbers: (Still acceptable for test)

12346192 Tube

12346193 Cartridge

**Specification**

- 1 89017816  
89017399 (Old)  
12480830 (Old)  
All part numbers are good
- 2 Seal / part of kit
- 3 Sealant (see note Z)

**View**

**Intake Gaskets**

Intake gasket installation

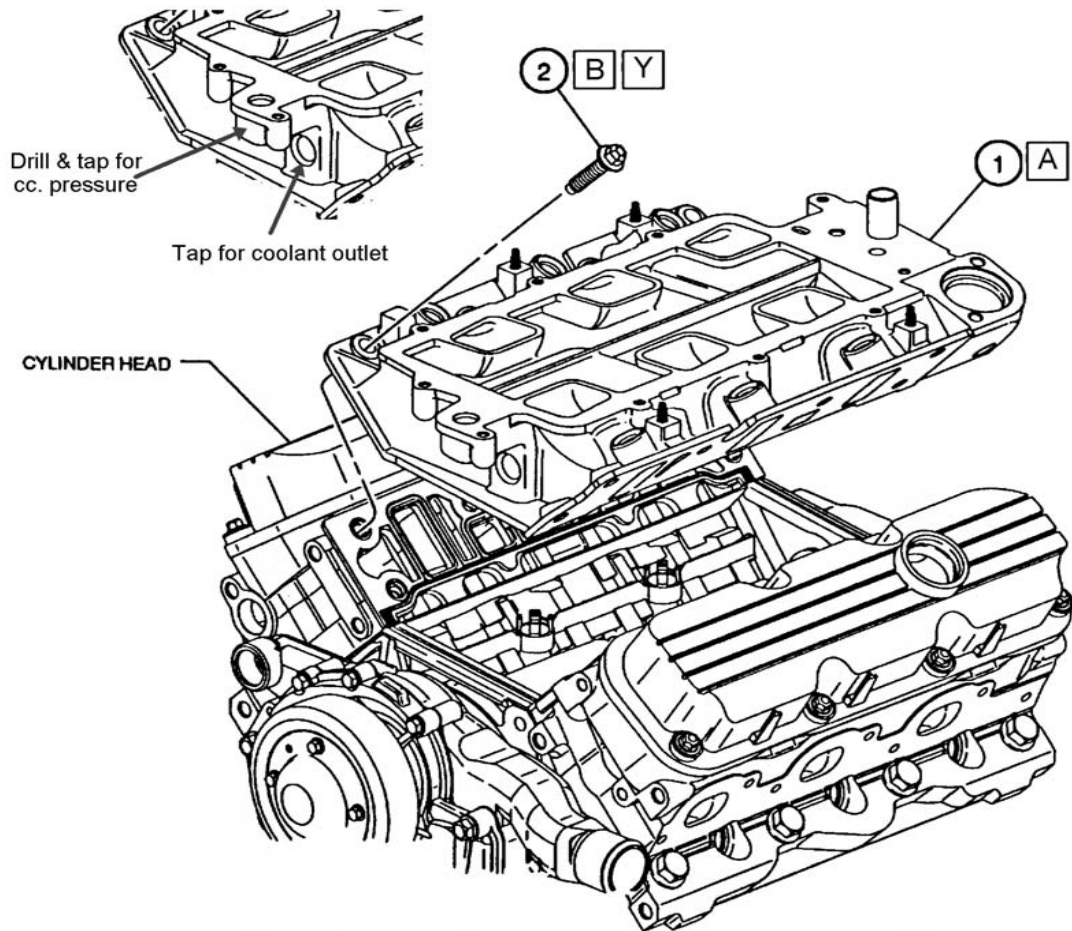
**Section**

6

**Sheet**

6

REV	Date	Revision History
1	1/6/1998	Block-44
2	12/15/03	Update RTV sealer
3	3/15/04	Update Intake Gasket Part Number and Silisone Sealer Information
4	7/20/06	Update Intake Gasket Part Number
<b>Long Block Assembly</b>		<b>Sequence III F</b>



**Description of Operation**

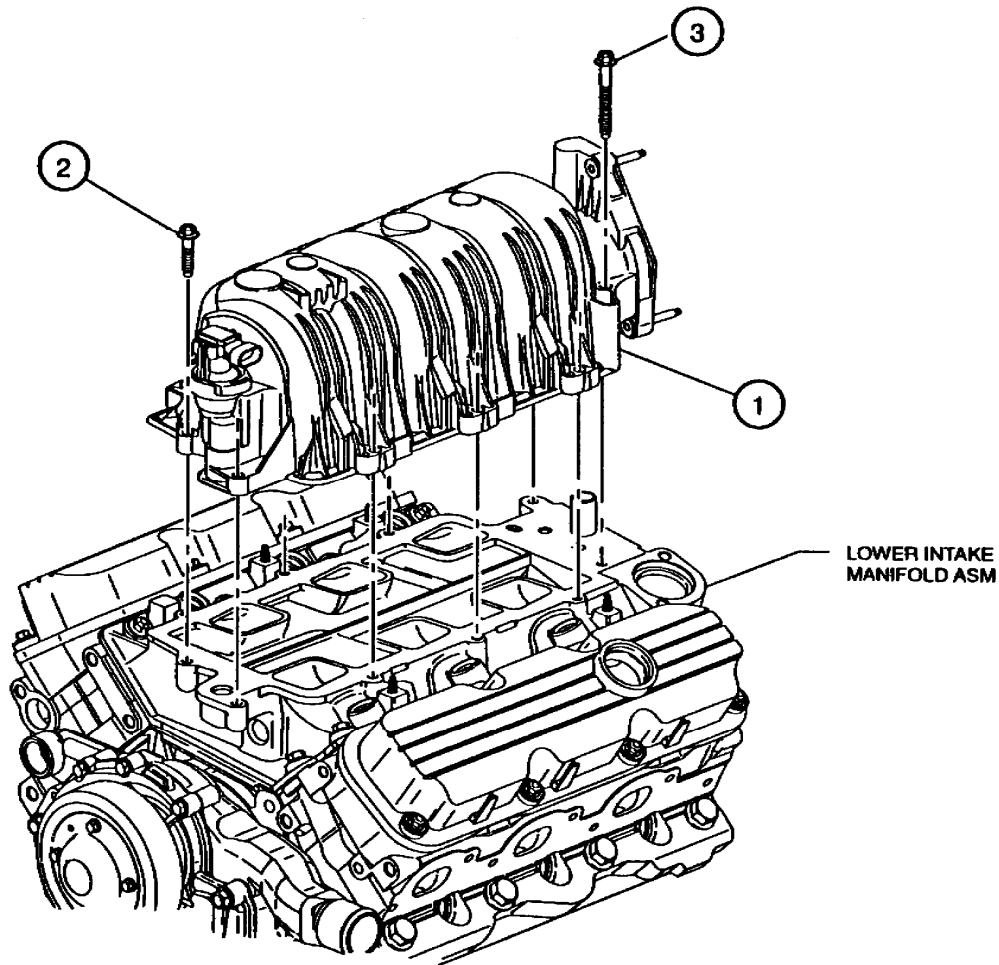
- A Install modified intake manifold
  - B Clean and lubricate bolts with Permatex #2 or RTV (see sec. 6 sheet 6 for RTV information) and install.
  - Y Torque 15Nm
- Drill and tap as indicated for the crankcase pressure line . Also tap coolant outlet port for coolant return line to process controller. Use a 3/4" I.D. unrestricted line for the return. Do not install shut off valves in the return line.

**Specification**

- 1 24505728 Manifold assembly
- 2 24504090 Bolt (12)

REV	Date	Revision History
1	1/6/1998	Block-45
Long Block Assembly		Sequence III F

View	
Lower Intake	
Lower intake manifold installation	
Section	Sheet
6	7



**Description of Operation**

Install upper intake and gasket assembly.

Torque 10Nm (Max. torque)

Y

**Specification**

- 1 17096162 Manifold assembly  
89017556 Gasket Kit
- 2 24506498 Bolt (8)
- 3 24505205 Bolt (2)

See note Y for torque

**View**

**Upper Intake**

Upper intake installation

REV	Date	Revision History
1	1/6/1998	Block-46
2	3/30/07	Update upper intake gasket part number new 89017556 old 17113137
3	3/5/10	Removed stud (number 3) and renumbered 4 as 3

**Long Block Assembly**

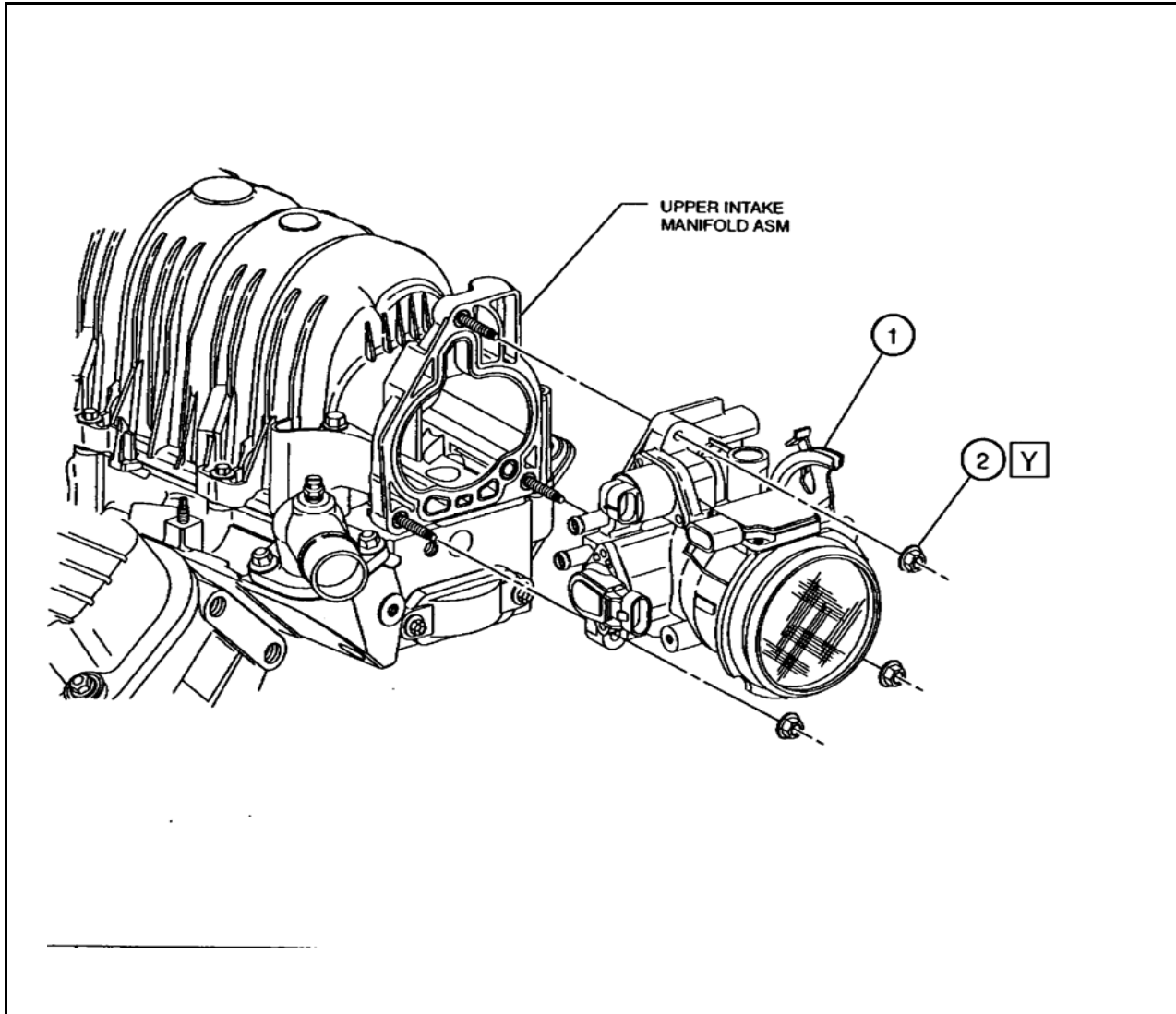
**Sequence III F**

**Section**

6

**Sheet**

8



**Description of Operation**

Install modified throttle body

**Note: See section 7 sheet 5 for modifications**

Y Torque 10Nm

**Specification**

1 24507235 Throttle Body  
(2 bolt Mass Air Flow Sensor)  
Use 12568877  
May be superseded with remanufactured part# 88961007

2 24506469 Nut

REV	Date	Revision History
1	1/6/1998	Block-47
2	4/28/03	Add new mass airflow part number 12568877
3	6/23/03	Add 88961007 remanufactured from 12568877

**View**

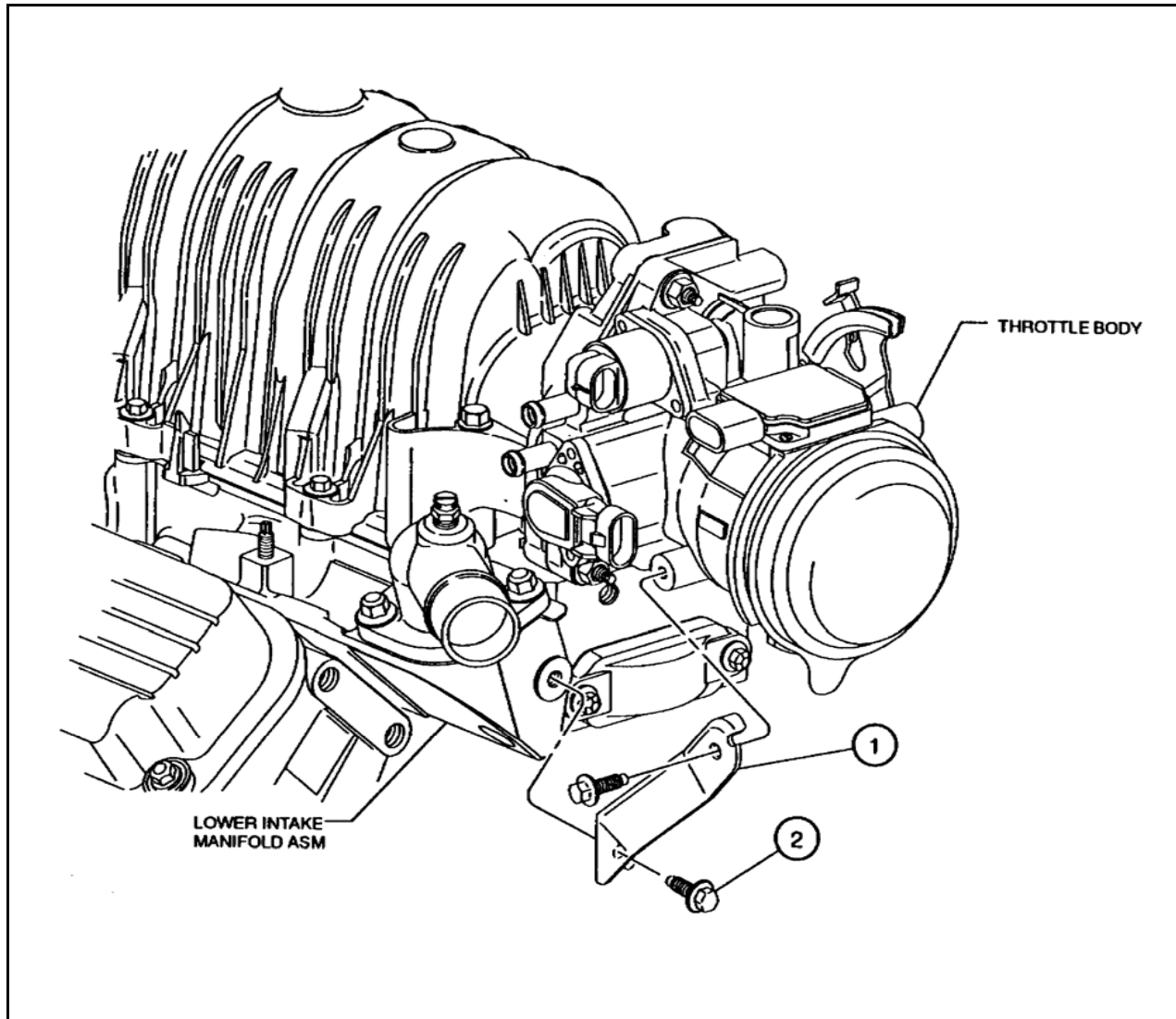
**Throttle Body**

Throttle body installation

**Long Block Assembly**

**Sequence IIIF**

Section	Sheet
6	9



Description of Operation	
	Install support bracket
Y	Torque 10Nm

Specification	
1	24504697 Support
2	24503644 Bolt (2) See note Y for torque

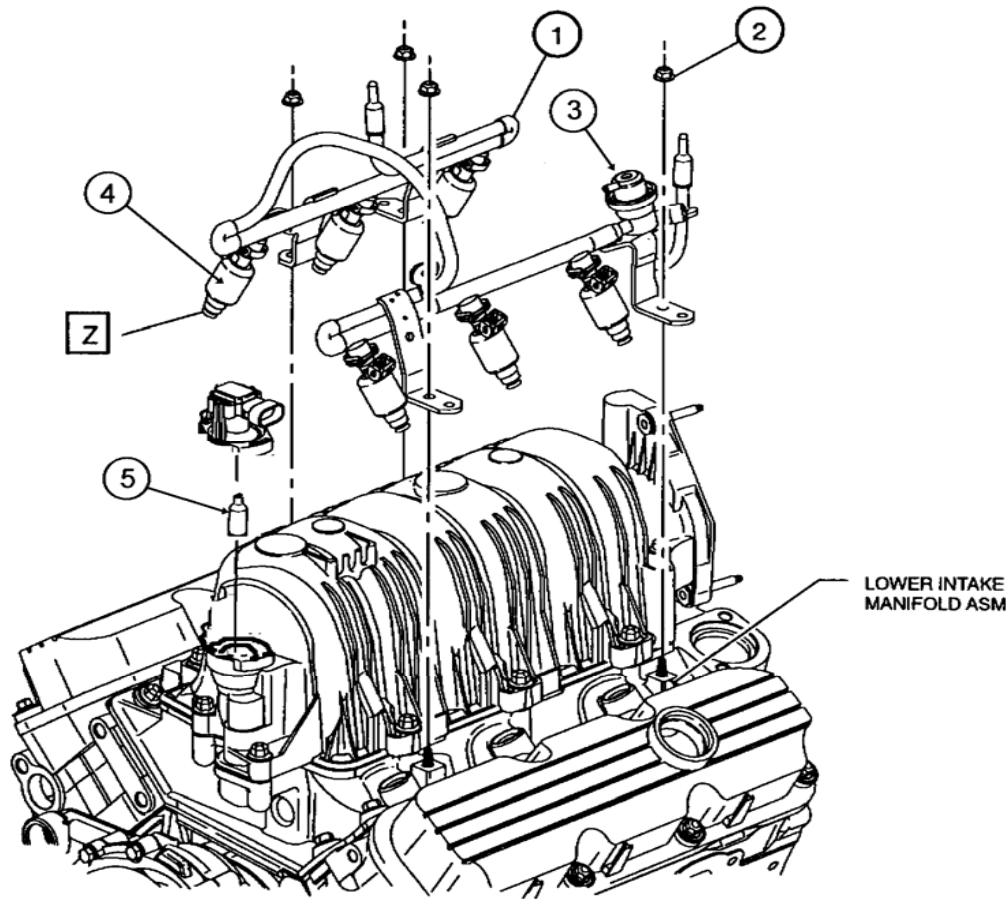
REV	Date	Revision History
1	1/6/1998	Block-48

View	
<b>Throttle Body Support</b>	
Throttle body support installation	

**Long Block Assembly**

**Sequence III F**

Section	Sheet
6	10



**Description of Operation**

Install injector assembly (See sec. 6.14.1 of the test procedure for injector flow testing requirements).

Y Torque 10Nm

Z Lubricate O-ring with EF-411

**Specification**

- 1 17098211 Fuel Rail
- 2 24506469 Nut
- 3 17113346 Regulator
- 4 17120601 Injector
- 5 OHT3F-002-1 PCV Dummy

**View**

**Injector Assembly**

Injector assembly installation

**Section**

6

**Sheet**

11

REV	Date	Revision History
1	1/6/1998	Block-49
2	12/15/03	Update text on reference to procedure for injector flow testing requirements

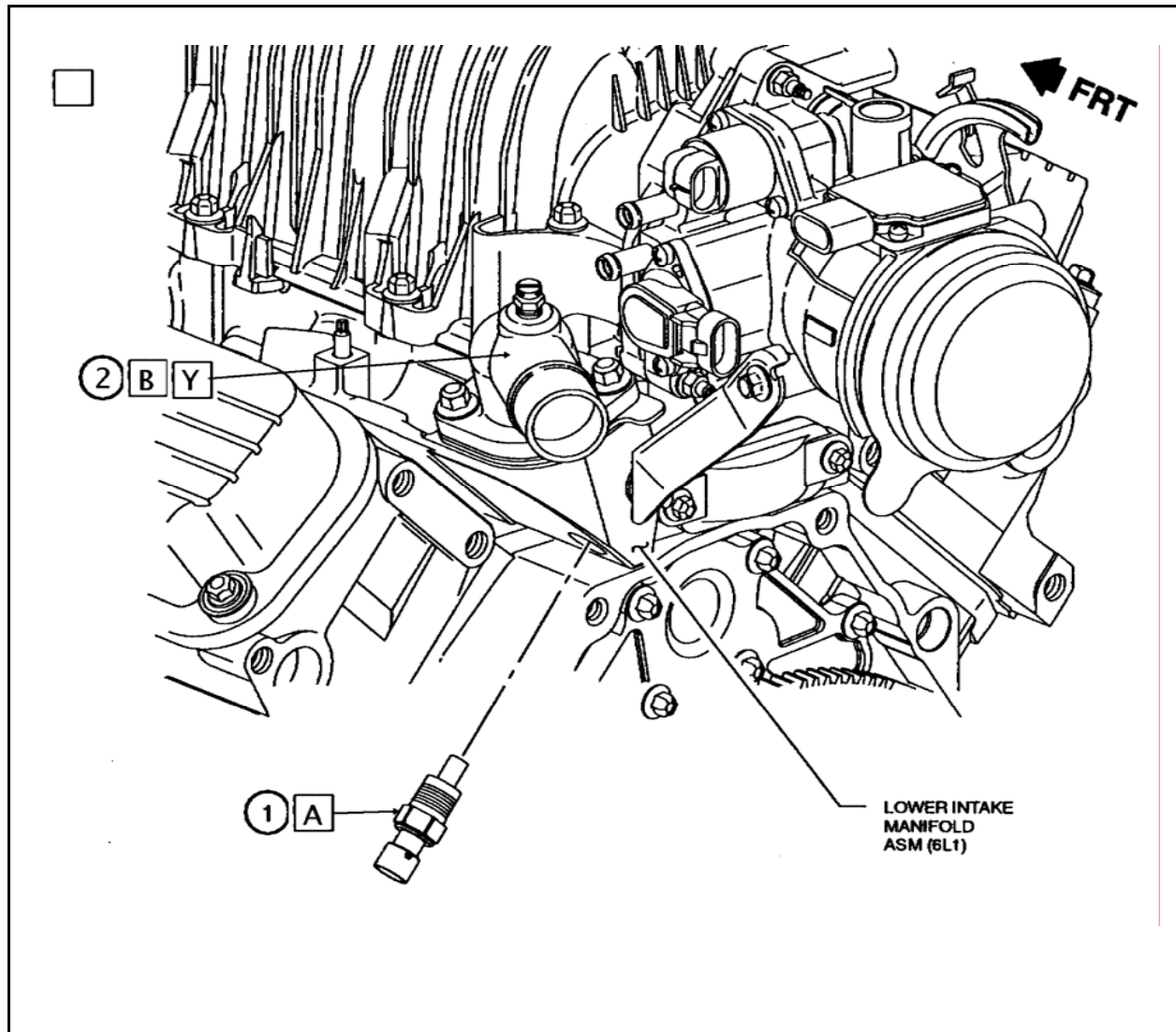
**Long Block Assembly**

**Sequence IIIF**

## **Section 7**

### **Final Dress**





Description of Operation	
A	Install production sensor as a plug only. <b>Do not use for connection to harness.</b> <b>Disable connector.</b>
B	Install coolant outlet
Y	Torque 27Nm

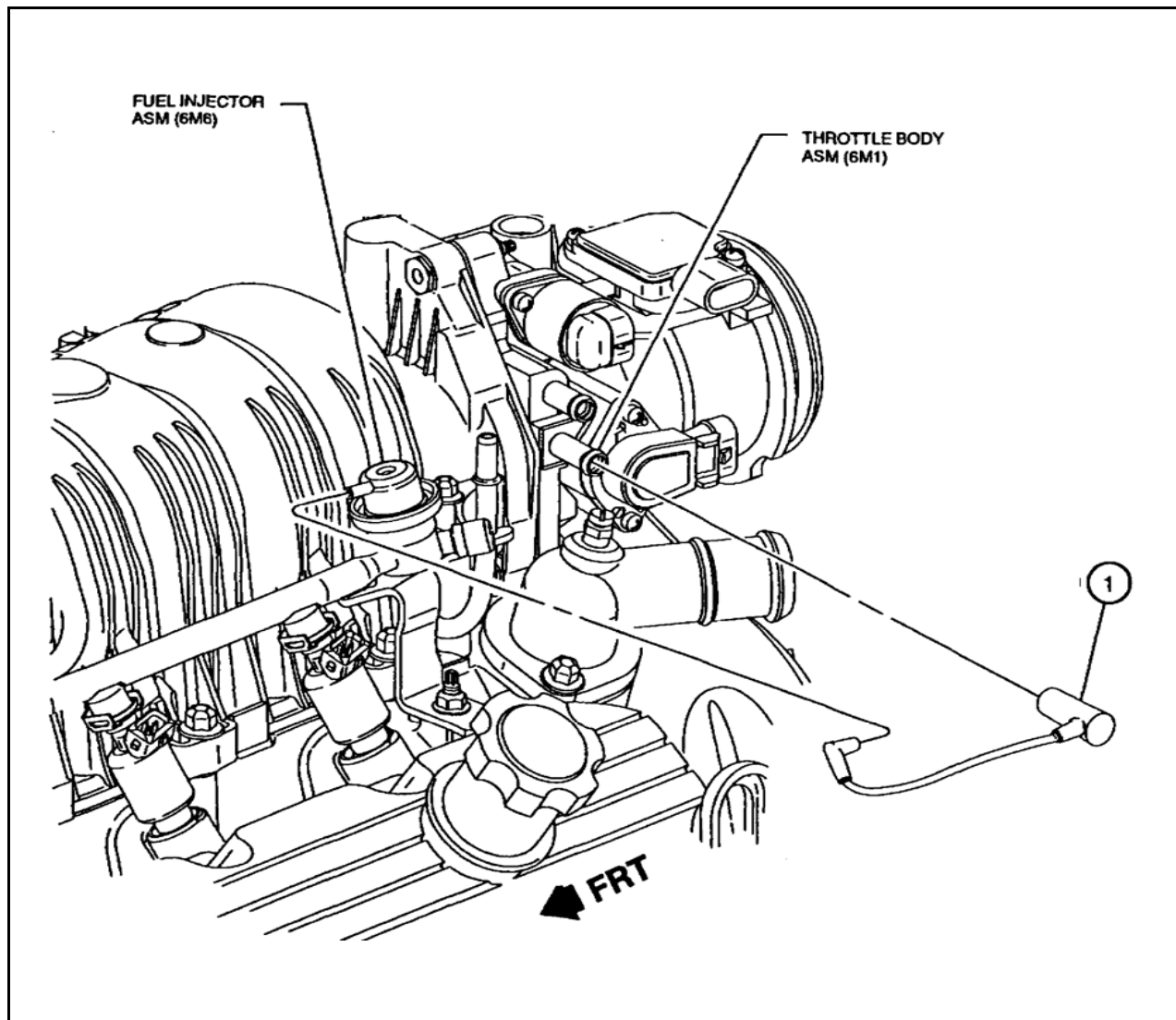
Specification	
1	10096181 Sensor (Used for plug only, disable connector)
2	OHT3F-034-1 Coolant Outlet (Not to detail on sheet)

REV	Date	Revision History
1	1/10/98	Block-51

View	
Coolant Out & Sensor	

Final Dress	Sequence III F
-------------	----------------

Section	Sheet
7	1



**Description of Operation**

Specification	
1	24505671 Tube

REV	Date	Revision History
1	1/10/98	Block-52

**View**

**Vacuum Hose**

**Final Dress**

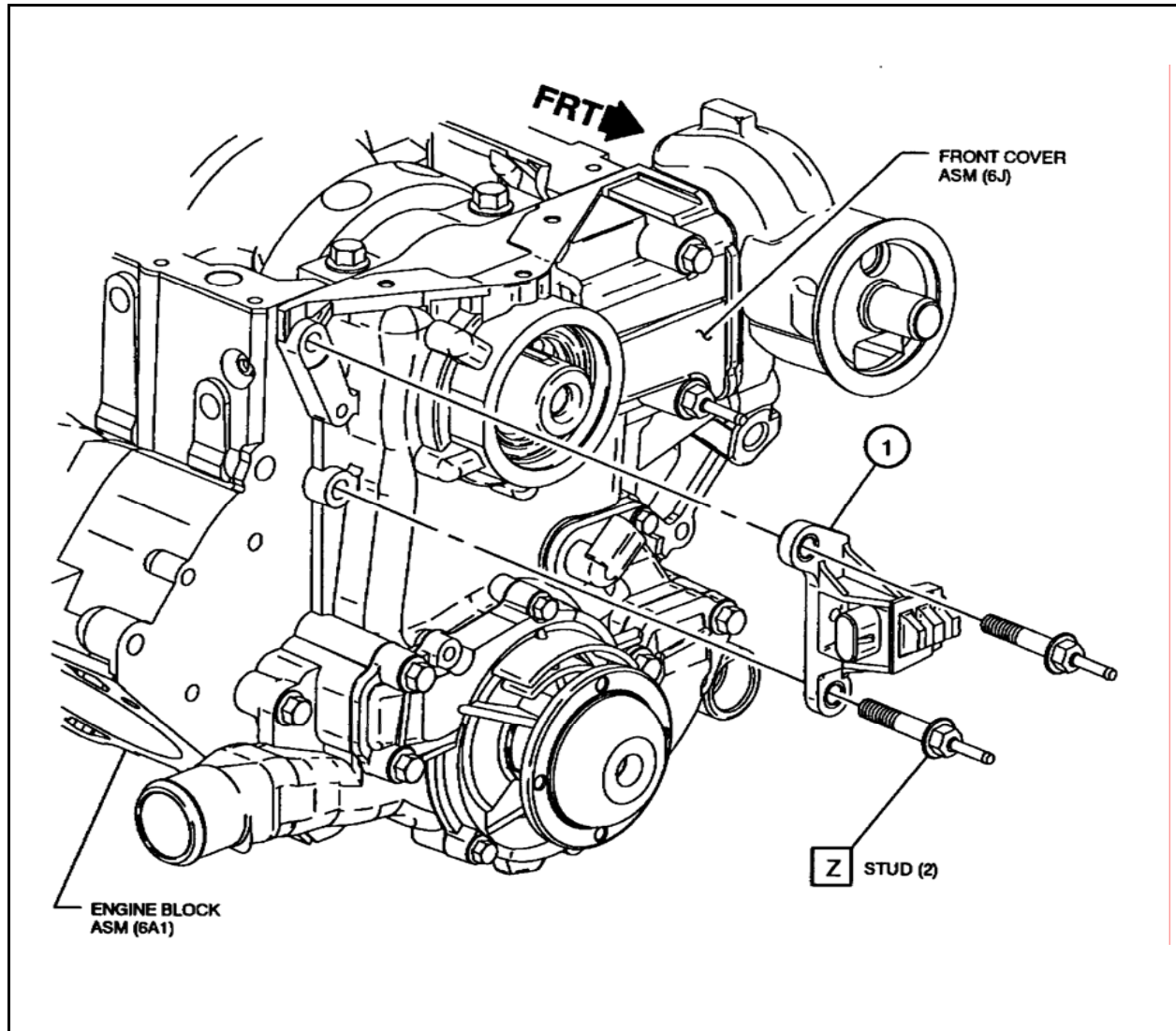
**Sequence III F**

**Section**

7

**Sheet**

2



**Description of Operation**

Z See front cover section for bolt part numbers and torque.

**Specification**

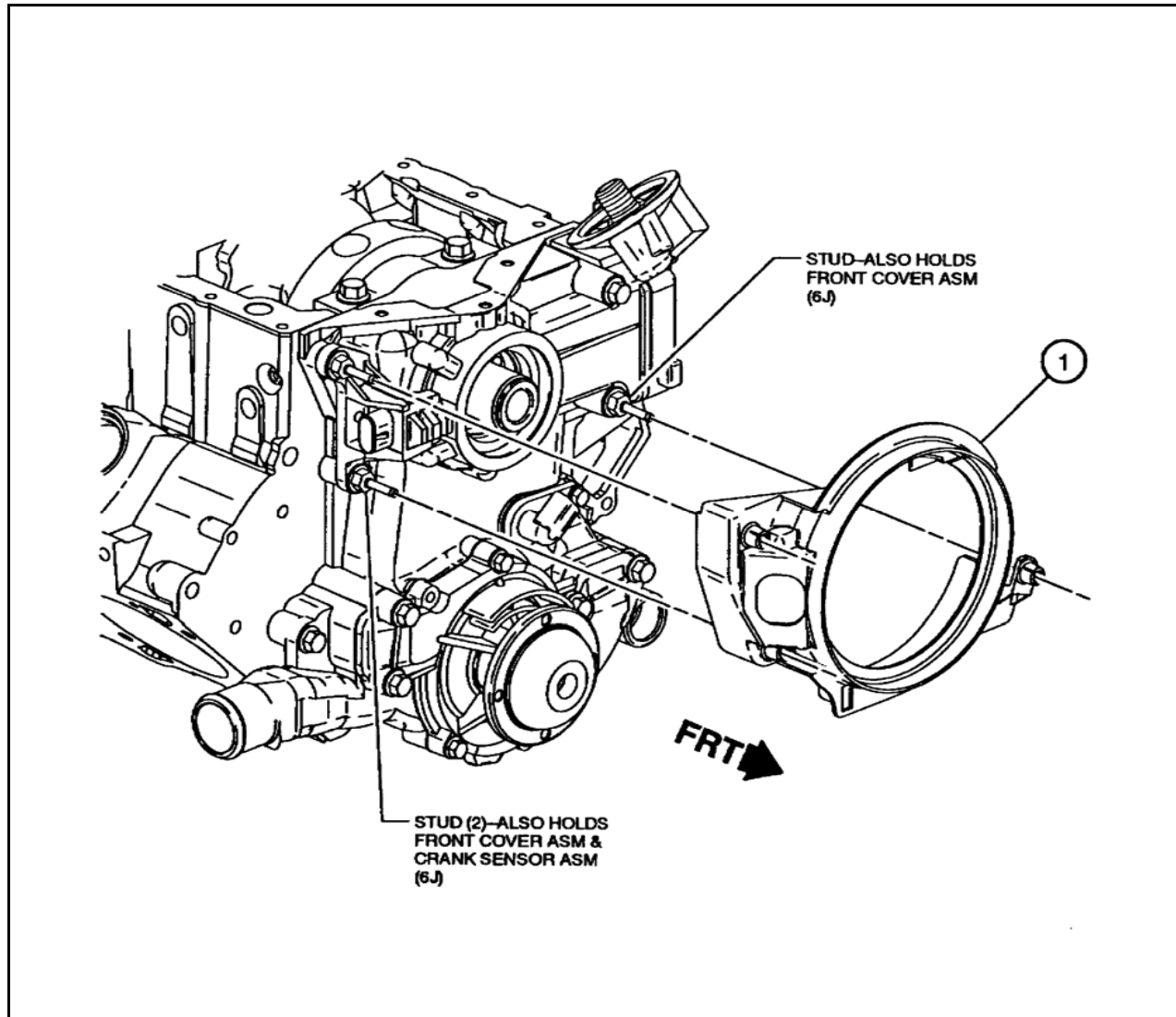
1	10456161 Sensor
---	-----------------

REV	Date	Revision History
1	1/10/98	Block-53
Final Dress		Sequence III F

**View**

**Crankshaft Sensor**

Section	Sheet
7	3



**Description of Operation**

**Specification**

1 24506440 or 24508586 Shield

REV	Date	Revision History
1	1/10/98	Block-54
2	12/15/03	Add 24508586

**View**

**Crankshaft Sensor Shield**

**Final Dress**

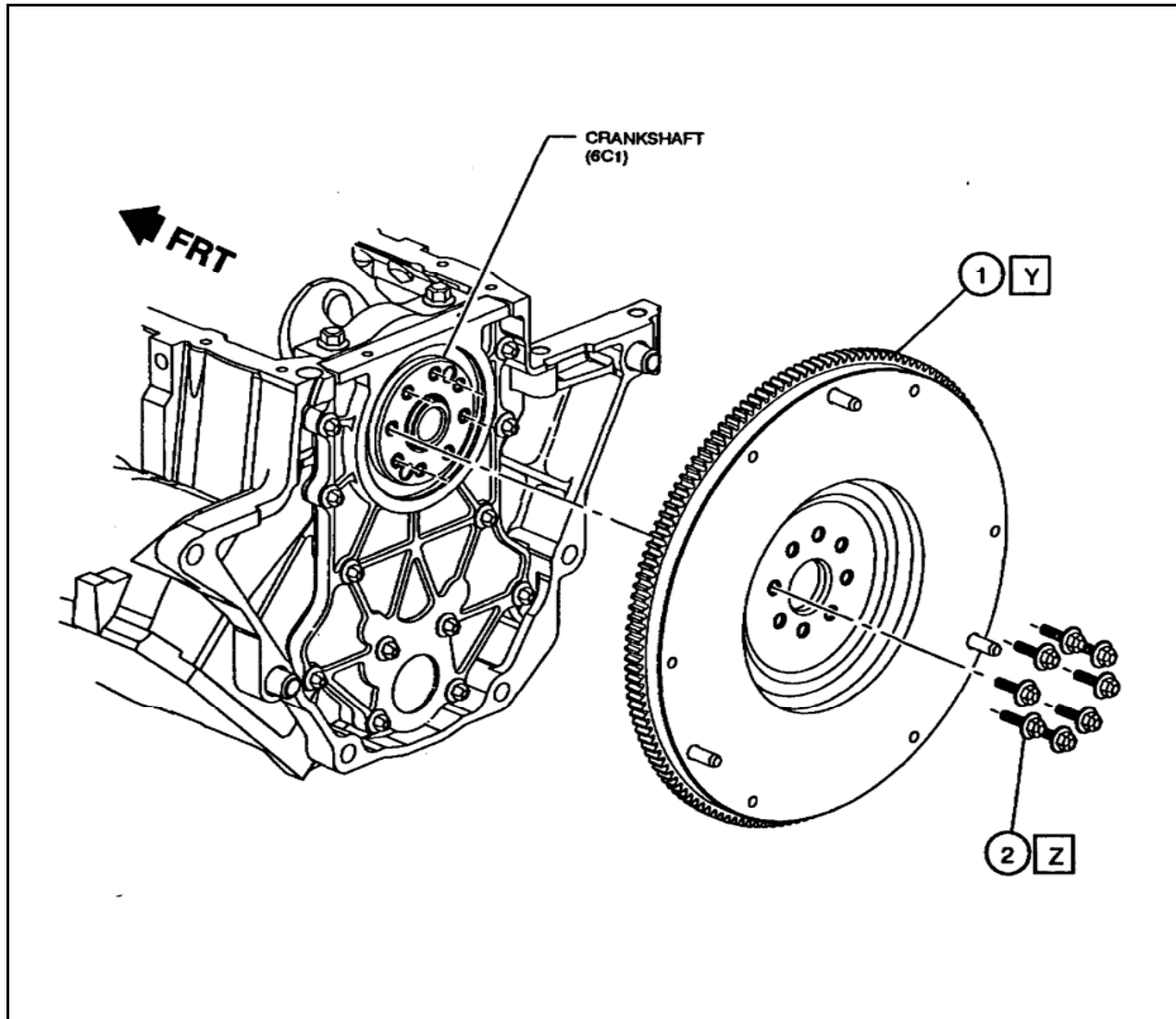
**Sequence III F**

**Section**

7

**Sheet**

4



Description of Operation	
Y	OHT-020-2 modified to fit offset balance and adapter plate for Dana 1550 four bolt yoke.
Z	Torque & Angle 15Nm + 50°

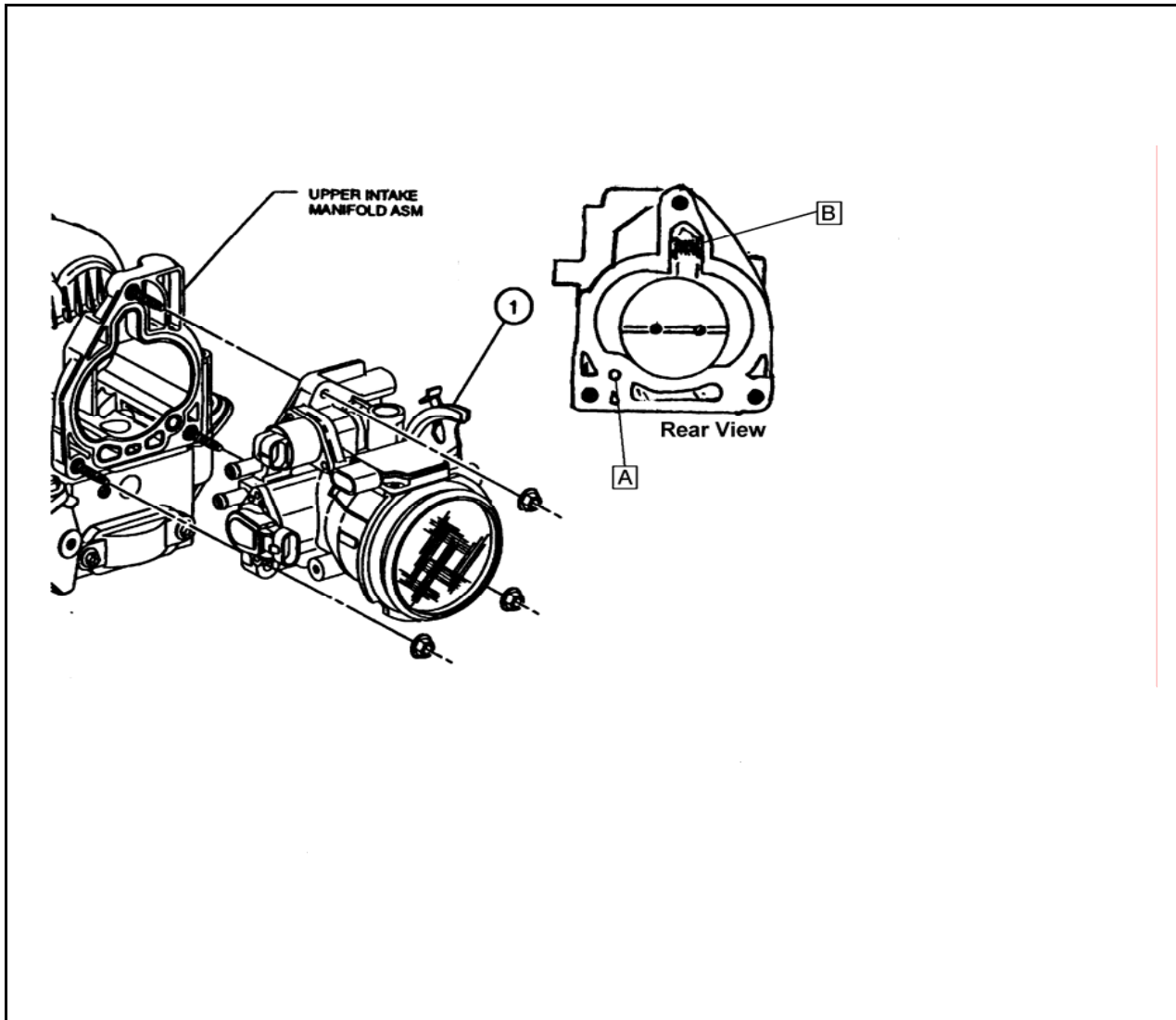
Specification	
1	OHT3F-020-2 Flywheel (Modified 24503285)
2	24505092 Bolt

REV	Date	Revision History
1	1/10/98	Block-55

View	
Flywheel	

Final Dress	Sequence III F
-------------	----------------

Section	Sheet
7	5



**Description of Operation**

A Drill and tap to receive a hex head plug

B Use power to PCM with engine not running and throttle blade open to drive Idle Air Control motor closed. Disconnect harness connector and adjust idle screw to obtain 800 RPM base idle.

As an alternative, the IAC may be removed and both ports plugged using epoxy and welch type plugs.

**Specification**

1 24507235 Throttle Body  
 (2 bolt Mass Air Flow Sensor)  
 Use 12568877  
 or  
 May be superseded with  
 remanufactured part# 88961007

REV	Date	Revision History
1	11/13/99	Block-48
2	5/28/03	Add 12568877
3	6/23/03	Add 88961007 remanufactured from 12568877

**View**

**Throttle Body Modification**

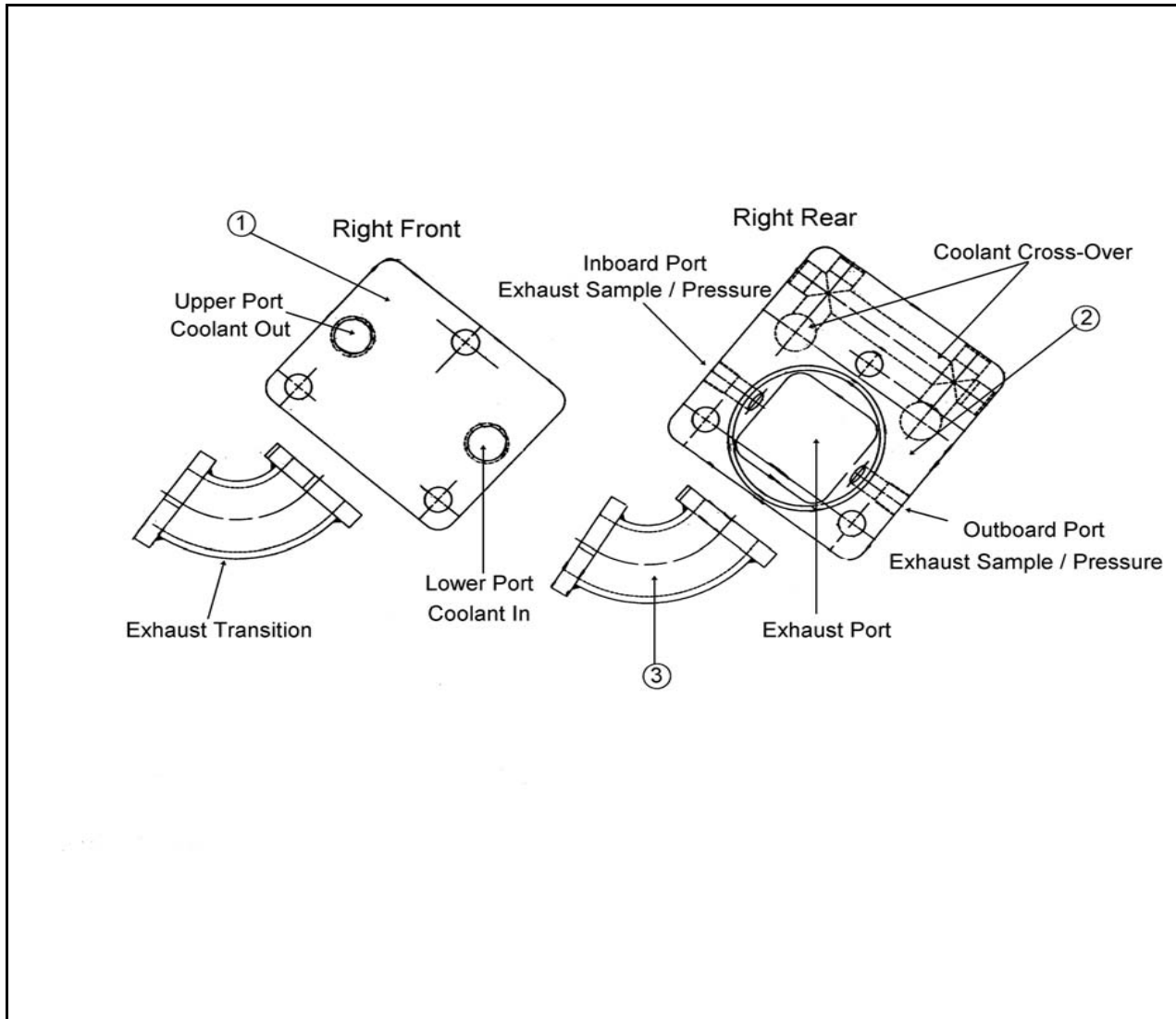
**Final Dress**

**Sequence III F**

Section	Sheet
7	6

## **Section 8**

### **OH Technologies Special Engine Dress**



**Description of Operation**

Water cooled exhaust manifold end plates and exhaust manifold transitions. Note: both views are right side showing the cooling water inlet is the lower port and the outlet is the higher port. Also, the inboard exhaust sample port is typically for the gas analysis and the outboard is for the back pressure connection.

The transition should be connected with shielded gaskets not shown but identified by part number. Two required per side.

Thermocouples for exhaust coolant in and out should be installed in the fittings attached to the front plate and centered in the coolant flow.

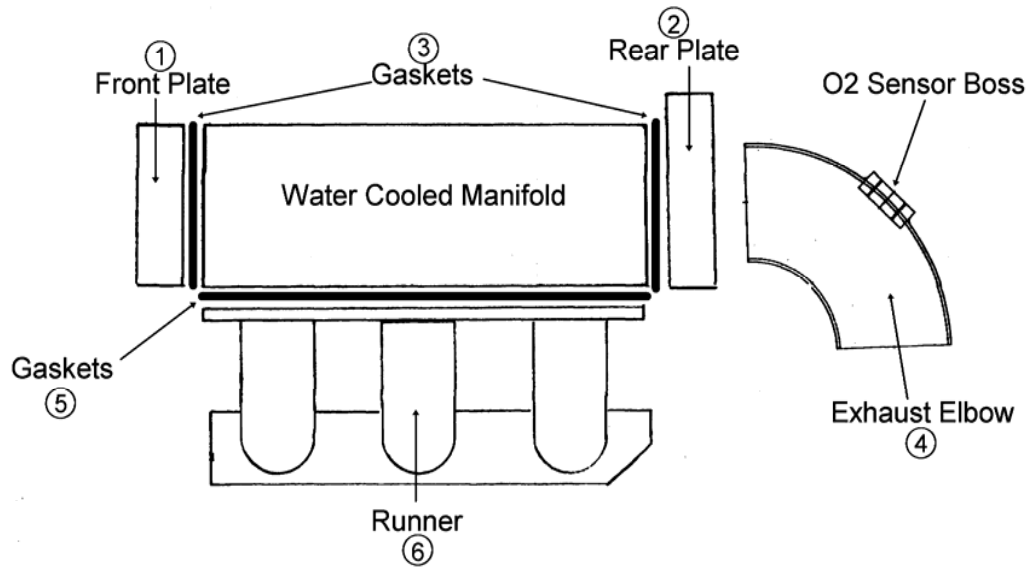
**Specification**

1 OHT3F-006-1 Plate, Rear Exhaust  
 2 OHT3F-005-1 Plate, Front Exhaust  
 3 OHT3F-004-1 Runner, Exh. Man.

REV	Date	Revision History
1	11/13/99	Block-60
2	2/22/02	Update View Exhaust sample / pressure locations
<b>OHT</b>		<b>Sequence III F</b>

<b>View</b>	
<b>Water Cooled Exh. Man. End Plates</b>	
<b>Section</b>	<b>Sheet</b>
8	1





**Description of Operation**

Water cooled exhaust manifold

Not to scale

**Note: Do Not Use RTV Sealer on O2 sensor or other exhaust system components upstream of O2 sensor.**

**Specification**

- 1 OHT3F-005-1 Plate, Front Exhaust
- 2 OHT3F-006-1 Plate, Rear Exhaust
- 3 OHT3F-009-1 Gasket, End Plate
- 4 OHT3F-005A-1 Elbow, Exh. Modified
- 5 OHT3F-018-1 Gasket Flange, Metal
- 6 OHT3F-004-1 Runner, Exh. Man.

REV	Date	Revision History
1	11/13/99	Block-61
2	2/22/02	Update text, include warning on usage of RTV sealer

**View**

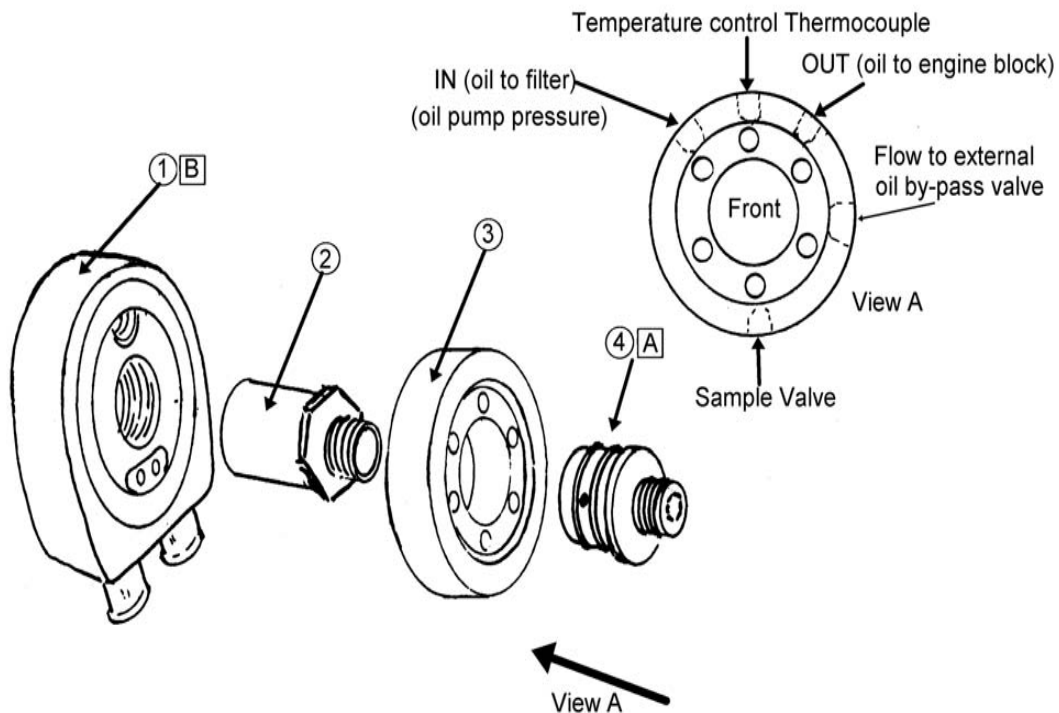
**Water Cooled Exh. Man. & Elbow**

**OHT**

**Sequence III F**

**Section**  
8

**Sheet**  
2



Note: See section 8 sheet 3a & 3b for additional information

**Description of Operation**

- A Replace "O"-rings every test.
- Note: View A  
 Viewed from front or oil filter side, passages are, IN (oil pump pressure to filter), center port for temperature control thermocouple, OUT (oil flow out of filter in to engine block), Side outlet to external oil by-pass valve, and lower port is for oil sample valve.
- B Replace oil cooler every test

**Specification**

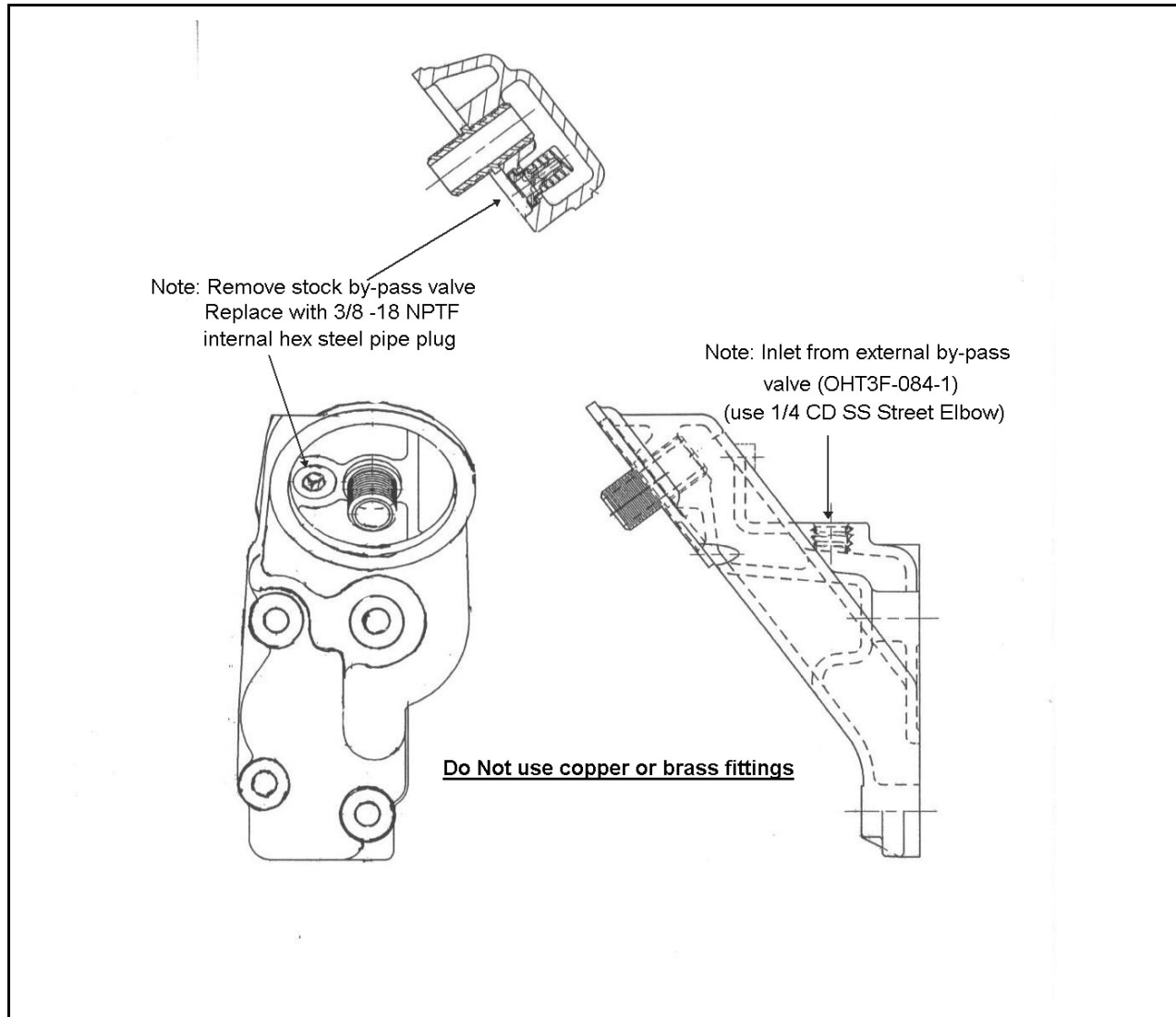
- 1 OHT3F-030-2 Cooler Nickel Plated
- 2 OHT3F-039-3 Connector Special Cut
- 3 OHT3F-035-2 Adapter, Oil Filter
- 4 OHT3F-043-2 Fitting, Oil Filter Adapter

REV	Date	Revision History
1	11/30/99	Block 62
2	6/17/02	Add notes, new part numbers and update view. See next sheet for further details

View	
<b>Oil Cooler Assembly</b>	

<b>OHT</b>	<b>Sequence III F</b>
------------	-----------------------

Section	Sheet
8	3



**Description of Operation**

Special part modification information.

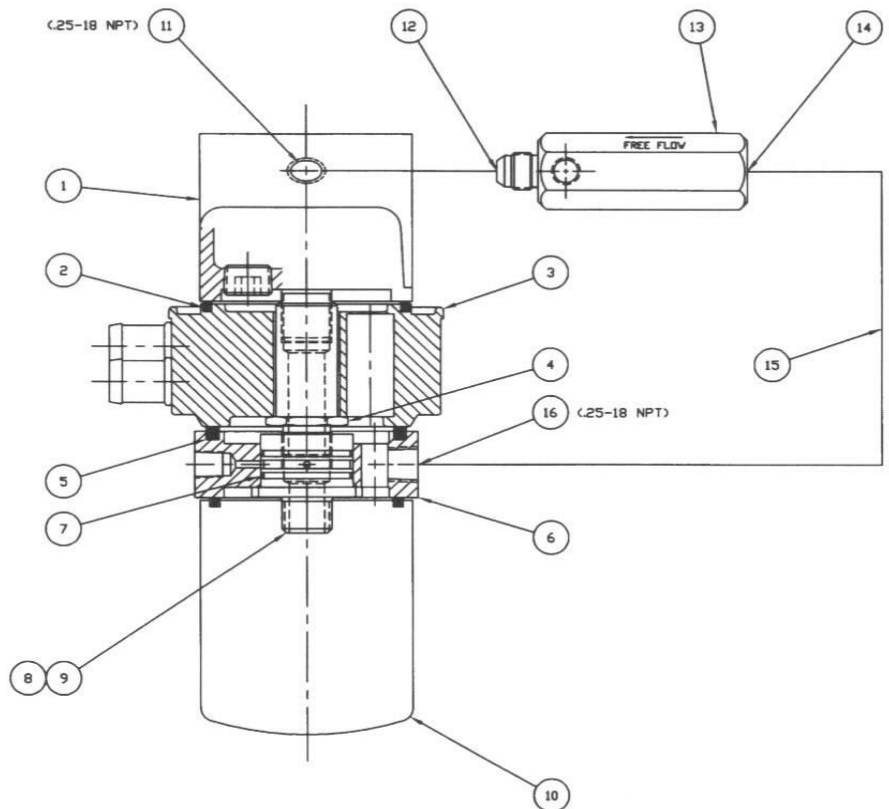
Modified part may be purchased direct from OHT (OHT3F-080-1)

**Specification**

1 24501300 Adapter, oil filter  
OHT3F-080-1 Modified

REV	Date	Revision History
<b>OHT</b>		<b>Sequence III F</b>

<b>View</b>	
<b>Oil Filter Adapter Modification</b>	
Section	Sheet
8	3a



BILL OF MATERIAL		
ITEM	REQ'D	DESCRIPTION
1	1	BLOCK, OIL FILTER, MODIFIED W/BYPASS BLOCKED, DHT3F-080-1
2	1	SEAL, RECTANGULAR, DHT3F-074-1
3	1	COOLER, OIL, NICKEL PLATED, BYPASS CLOSED, DHT3F-030-2
4	1	CONNECTOR, MODIFIED, DHT3F-039-3
5	1	SEAL, RECTANGULAR, DHT3F-062-1
6	1	ADAPTER, OIL FILTER, DHT3F-035-2
7	2	SEAL, O-RING, #2-025-VITON PARKER
8	1	FITTING, OIL FILTER ADAPTER, .500" I.D., DHT3F-043-2
9	1	WRENCH, SPANNER, (FOR USE W/ITEM #8), DHT3F-083-1
10	1	FILTER, OIL (PF-47), DHT3F-057-1
11	1	ELBOW, STREET, #1/4 CD-SS PARKER
12	1	CONNECTOR, SWIVEL, #6 F6X-SS PARKER
13	1	HOUSING, ASS'Y, BYPASS VALVE, DHT3F-084-1
14	1	CONNECTOR, MALE, #6-BFTX-SS PARKER
15	1	(.31 I.D. X 12.00 LG.) BRAIDED TEFLON HOSE ASS'Y, #K9190606-060606C-012.0 PARKER
16	1	CONNECTOR, MALE, #6FTX-SS PARKER

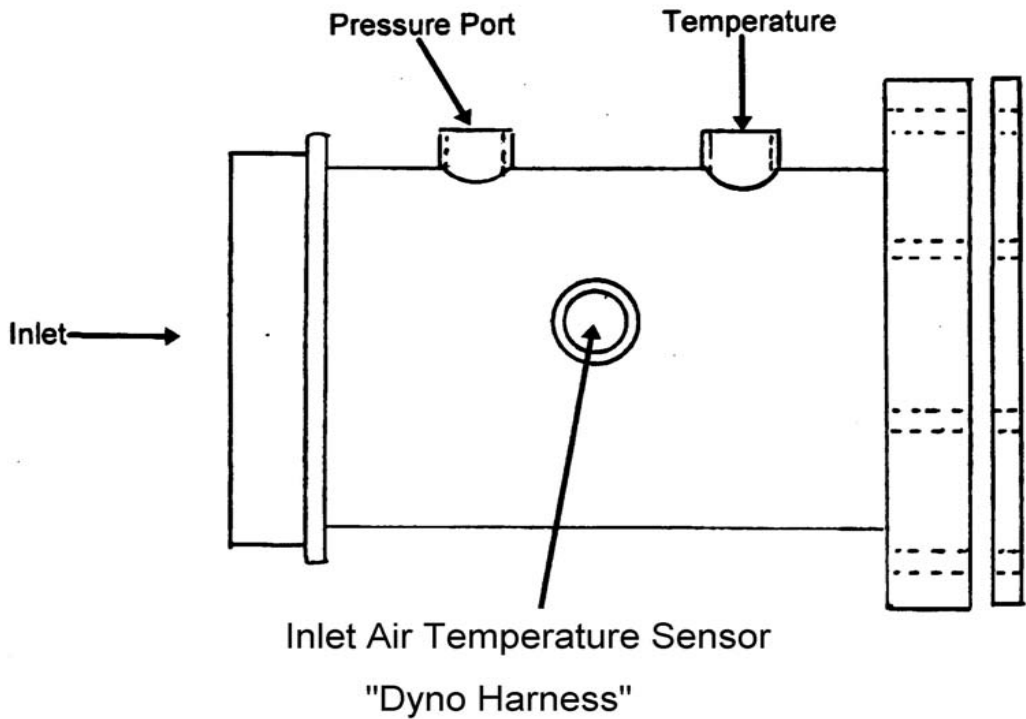
ASSEMBLE ALL SEALS WITH A LIGHT COATING OF #EF411 OIL

DIMENSIONS IN PARENTHESES ARE IN INCHES

METRIC			
UNLESS OTHERWISE SPECIFIED DIMENSIONS ARE IN MILLIMETERS			
TOLERANCES UNLESS SPECIFIED	TITLE	SYN	REVISES
DECIMAL XX = .03 XXX = .010	ASS'Y, OIL FILTER, COOLER & BYPASS		DATE
ANGULAR .11"	MATERIAL SEE B/M	CHECKED BY	DRAWN BY D.H.
SURFACES 1/2	SCALE FULL	D.H.	ASSEMBLY
	DATE 6-6-02		
OH TECHNOLOGIES INC.		DWG. NO.	DHT3G-XXX-1
P.O. BOX 1009 MONTICELLO, TN 37133			

© COPYRIGHT OH TECHNOLOGIES, INC., 2002  
ALL RIGHTS RESERVED

REV	Date	Revision History	View	
1	6/17/02	OHT Print	OHT Oil Cooling & By-Pass	
			Printed by permission OH Technologies	
			Section	Sheet
			8	3b
OHT		Sequence IIIF		



**Description of Operation**

Inlte air adapter  
 Use pressure port for hookup to transducer, temperature for thermocouple (centered in flow), and inlet air pressure sensor port for Dyno Harness sensor.

**Specification**

OHT3F-001-2 Adapter, Throttle Body

REV	Date	Revision History
1	11/30/99	Block-63
2	2/22/02	Update View, Inlet Air Temp. Sensor

**View**

**Adapter, Throttle Body**

**Section**

8

**Sheet**

4

**OHT**

**Sequence III F**