

Sequence IIIF
Test Procedure

Draft Number 3a
Updated with IL 00-2

October 4, 2000

ASTM Designation: D XXXX -

Standard Test Method for Evaluation of Automotive Engine Oils in the Sequence IIIF, Spark-Ignition Engine¹

This standard is issued under the fixed designation D XXXX; the number immediately following the designation indicates the year of original adoption or, in the case of revision, the year of last revision. A number in parentheses indicates the year of last reapproval. A superscript epsilon ([epsilon]) indicates an editorial change since the last revision or reapproval.

This document is not an ASTM standard; it is under consideration within an ASTM technical committee but has not received all approvals required to become an ASTM standard. It shall not be reproduced or circulated or quoted, in whole or in part, outside of ASTM committee activities except with the approval of the chairman of the committee having jurisdiction and the president of the society. Copyright ASTM, 100 Barr Harbor Drive, West Conshohocken, PA 19428-2959.

The test method described in this standard can be used by any properly equipped laboratory, without the assistance of anyone not associated with that laboratory. However, the ASTM Test Monitoring Center (TMC) provides reference oils and an assessment of the test results obtained on those oils by the laboratory (see Annex xx). By this means, the laboratory will know whether their use of the test method gives results statistically similar to those obtained by other laboratories. Furthermore, various agencies require that a laboratory utilize the TMC services in seeking qualification of oils against specifications. For example, the U.S. Army imposes such a requirement, in connection with several Army engine lubricating oil specifications.

Accordingly, this test method is written for use by laboratories which utilize the TMC services. Laboratories which choose not to use those services may simply ignore those portions of the test method which refer to the TMC.

This test method may be modified by means of Information Letters issued by the TMC. In addition, the TMC may issue supplementary memoranda related to the test method (see Annex A1).

1. Scope (START)

1.1 This test method covers an engine test procedure for evaluating automotive engine oils for certain high-temperature performance characteristics, including oil thickening, sludge and varnish deposition, and oil consumption, as well as engine wear. Such oils include both single viscosity grade and multiviscosity grade oils which are used in both spark-ignition, gasoline-fueled engines, as well as in diesel engines.

Note 1-Companion test methods used to evaluate engine oil performance for specification requirements are discussed in SAE J304.

1.2 The values stated in SI units are to be regarded as the standard. The values given in parenthesis are provided for information purposes only.

1.3 This standard does not purport to address all of the safety concerns, if any, associated with its use. It is the responsibility of the user of this standard to establish appropriate safety and health practices and determine the applicability of regulatory limitations prior to use.

1.4 This test method is arranged as follows:

Subject	Section
Introduction	
Scope	1
Referenced Documents	2
Terminology	3
Summary of Test Method	4
Significance and Use	5
Apparatus	6
Laboratory	6.1
Drawings	6.2
Specified Equipment	6.3
Test Engine	6.4
Engine Parts	6.4.1
Engine Speed and Load Control	6.5
Engine Cooling System	6.6.1
Flushing Tank	6.7
Coolant Mixing Tank	6.8
Breather Tube Cooling Systems	6.9
Engine Oil-Cooling System	6.10
Fuel System	6.11
Induction Air Supply Humidity, Temperature, and Pressure	6.12
Temperature Measurement	6.13
Subject	Section

Thermocouple Location	6.13.1
Air-to-Fuel Ratio Determination	6.14
Injector Flow Testing	6.14.1
Exhaust and Exhaust Back Pressure Systems	6.15
Blowby Flow Rate Measurement	6.16
Pressure Measurement and Sensor Location	6.17
Reagents and Materials	7
Test Fuel	7.1
Additive Concentrate for the Coolant	7.2
Coolant Preparation	7.3
Pre-Test Cleaning Materials	7.4
Sealing and Anti-seize Compounds	7.5
Hazards	8
Test Oil Sample Requirements	9
Preparation of Apparatus	10
Breather Tube Cleaning	10.1
Intake Manifold Cleaning	10.3
Cleaning of Engine Parts (other than the block and heads)	10.4
Engine Block Cleaning	10.5
Cylinder Head Cleaning	10.6
Engine Build-up Procedure	10.7
General Information	10.7.1
Special Parts	10.7.2
Hardware Information	10.7.3
Sealing Compound Applications	10.7.4
Fastener Torque Specifications and Torquing Procedures	10.7.5
Main Bearing Cap Bolts	10.7.5.1
Cylinder Head Bolts	10.7.5.2
Torques for Miscellaneous Bolts, Studs, and Nuts	10.7.5.3
Parts Replacement	10.8
Engine Block Preparation	10.9
Piston Fitting and Numbering	10.10
Piston Ring Fitting	10.10.1
Pre-Test Camshaft and Lifter Measurements	10.11
Camshaft Bearing Installation	10.12
Camshaft Installation	10.13
Main Bearings	10.14
Crankshaft Installation	10.14.1
Main Bearing Cap Installation	10.14.2
Crankshaft Sprocket	10.15
Camshaft Sprocket and Timing Chain	10.16

Subject	Section
Crankshaft End Play	10.17
Piston Pin Installation	10.18
Piston Installation	10.18.1
Harmonic Balancer	10.19
Connecting Rod Bearings	10.20
Engine Front Cover	10.21
Coolant Inlet Adapter	10.22
Oil Dipstick Hole	10.23
Oil Pan	10.24
Cylinder Head Assembly	10.25
Adjustment of Valve Spring Loads	10.26
Cylinder Head Installation	10.27
Hydraulic Valve Lifters	10.28
Pushrods	10.29
Valve Train Loading	10.30
Intake Manifold	10.31
Rocker Covers	10.32
Water Inlet Adapter	10.33
Breather Tube	10.34
Coolant Outlet Adapter	10.35
Oil Filter Adapter	10.36
Oil Sample Valve	10.37
Ignition System	10.38
Throttle Body	10.39
Accessory Drive Units	10.40
Exhaust Manifolds, Water-Cooled	10.41
Engine Flywheel	10.42
Pressure Checking of Engine Coolant System	10.43
Lifting of Assembled Engines	10.44
Mounting the Engine on the Test Stand	10.45
External Cooling System Cleaning	10.46
Engine Coolant Jacket Cleaning (Flushing)	10.47
Coolant Charging	10.48
Test Oil Charging	10.49
Engine Oil Pump Priming	10.50
Calibration	11
Laboratory and Engine Test Stand Calibration	11.1
Testing of Reference Oils	11.2
Reference Oil Test Frequency	11.3
Reporting of Reference Oil Test Results	11.4
Evaluation of Reference Oil Test Results	11.5
Status of Non-reference Oil Tests Relative to Reference Oil Tests	11.6
Status of Test Stands Used for Non-Standard Tests	11.7
Data Acquisition and Control	11.8
Sample Rate	11.8.1
Subject	Section

Measurement Accuracy	11.8.2
Temperature	11.8.3
Pressure	11.8.4
Flow	11.8.5
Speed	11.8.6
Load	11.8.7
Measurement Resolution	11.8.8
System Time Response	11.8.9
Quality Index	11.8.10
Engine Operating Procedure	12
Dipstick and Hole Plug	12.1
Induction Air Inlet Supply Line	12.2
Engine Start-up and Shutdown Procedures	12.3
Start-up	12.4
Shutdown	12.5
Non-Scheduled Shutdowns	12.6
Oil Sampling	12.7
Oil Leveling	12.8
Checks for Glycol Contamination	12.9
Air-to-Fuel-Ratio Measurement and Control	12.10
Blowby Flow Rate Measurement	12.11
NOx Determinations	12.12
Data Recording	12.13
Initial run (Ten Minutes)	12.14
Engine Oil Quality Testing (80 Hours)	12.15
Test Termination	12.16
Determination of Test Results	13
Engine Disassembly	13.2
Preparation of Parts for Rating of Sticking, Deposits, and Plugging	13.3
Rating Environment	13.4
Part Sticking	13.5
Sludge Rating	13.6
Piston Skirt Deposits Rating	13.7
Oil Ring Land Deposits Rating	13.8
Part Plugging Observations	13.9
Visual Inspection for Scuffing and Wear	13.10
Post-Test Camshaft and Lifter Wear Measurements	13.11
Used Oil Sample Testing	13.12
Viscosity Test	13.13
Blowby Flow Rate Measurements	13.14
Oil Consumption Computation	13.15
Photographs of Test Parts	13.16
Retention of Representative Test Parts	13.17
Severity Adjustments	13.18
Determination of Operational Validity	13.19

Subject	Section
Report	14
Report Forms	14.1
Use of SI Units	14.2
Precision of Reported Units	14.3
Deviations from Test Operational Limits	14.4
Oil Pressure Plot	14.5
Precision and Bias	15
Keywords	16

Annexes

The Role of the ASTM Test Monitoring Center (TMC) and the Calibration Program	A1
Sequence IIIIF Engine Test Parts	A2
Sequence IIIIF Test Parts and Drawings	A3
Sequence IIIIF Test Fuel Analysis	A4
Sequence IIIIF Test Control Chart Technique for Developing and Applying Severity Adjustments	A5
Sequence IIIIF Test Reporting	A6
Sequence IIIIF Test Air-to-Fuel Ratio	A7
Sequence IIIIF Test Set Points and Control States	A8
Sequence IIIIF Quality Index Calculation, Equation Variables	A9
Sequence IIIIF Engine Oil Level Worksheet	A10

Appendixes

Sequence IIIIF Test-Rating Worksheets	X4
---------------------------------------	----

2. Referenced Documents

2.1 ASTM Standards:

- D 16 Definitions of Terms Relating to Paint, Varnish, Lacquer, and Related Products³
- D 86 Test Method for Distillation of Petroleum Products
- D 130 Test Method for Detection of Copper Corrosion from Petroleum Products by the Copper Strip Tarnish Test
- D 156 Test Method for Saybolt Color of Petroleum Products (Saybolt Chronometer Method)
- D 235 Specification for Mineral Spirits (Petroleum Spirits) (Hydrocarbon Dry Cleaning Solvent)
- D 287 Test Method for API Gravity of Crude Petroleum and Petroleum Products (Hydrometer Method)⁴
- D 323 Test Method for Vapor Pressure of Petroleum Products (Reid Method)
- D 381 Test Method for Existent Gum in Fuels by Jet Evaporation
- D 445 Test Method for Kinematic Viscosity of Transparent and Opaque Liquids (and the Calculation of Dynamic Viscosity)
- D 525 Test Method for Oxidation Stability of Gasoline (Induction Period Method)
- D 1266 Test Method for Sulfur in Petroleum Products (Lamp Method)
- D 2422 Classification of Industrial Fluid Lubricants by Viscosity System
- D 2699 Test Method for Knock Characteristics of Motor Fuels by the Research Method
- D 2700 Test Method for Knock Characteristics of Motor and Aviation Fuels by the Motor Method
- D 2982 Test Methods for Detecting Glycol-Base Antifreeze in Used Lubricating Oils
- D 3237 Test Method for Lead in Gasoline by Atomic Absorption Spectrometry
- D 4175 Terminology Relating to Petroleum, Petroleum Products, and Lubricants
- D 4485 Specification for Performance of Engine Oils
- D 4684 Standard Test Method for Determination of Yield Stress and Apparent Viscosity of Engine Oils At Low Temperature
- D 5119 Test Method for Evaluation of Automotive Engine Oils in the CRC L-38 Spark-Ignition Engine
- D 5302 Test Method for Evaluation of Automotive Engine Oils for Inhibition of Deposit Formation and Wear in a Spark-Ignition Internal Combustion Engine Fueled with Gasoline and Operated Under Low-Temperature, Light-Duty Conditions
- D 5293 Standard Test Method for Apparent Viscosity of Engine Oils Between -5 and -30°C Using the Cold-Cranking Simulator
- E 29 Practice for Using Significant Digits in Test Data to Determine Conformance with Specifications
- E 270 Definitions of Terms Relating Liquid Penetrant Examination
- E 344 Terminology Relating to Thermometry and Hydrometry

E 380 Practice for Use of the International System of Units (SI)
(The Modernized Metric System)

G 40 Terminology Relating to Wear and Erosion

2.2 Military Specification:

MIL-L-2104, Lubricating Oil, Internal Combustion Engine, Tactical
Service

2.3 SAE Standards:

J183, Engine Oil Performance and Engine Service Classification
(Other Than "Energy-Conserving")

J304, Engine Oil Tests

2.4 Sequence IIIF-specific Documents:

Sequence IIIF Engine Assembly Manual

Data Acquisition and Control Automation II Task Force Report

ASTM Test Monitoring Center, System Time Response Measurement
Guidelines, 5/27/99

3. Terminology

3.1 Definitions:

3.1.1 blowby, n-in internal combustion engines, the combustion products and unburned air-and-fuel mixture that enter the crankcase.

3.1.2 BTDC, adj-abbreviation for Before Top Dead Center; used with the degree symbol to indicate the angular position of the crankshaft relative to its position at the point of uppermost travel of the piston in the cylinder.

3.1.3 calibrate, v-to determine the indication or output of a measuring device with respect to that of a standard. E 344

3.1.4 clogging, n-the restriction of a flow path due to the accumulation of material along the flow path boundaries.

3.1.5 cold-stuck piston ring, n-in internal combustion engines, a piston ring that is stuck when the piston and ring are at room temperature, but inspection shows that it was free during engine operation. Subcommittee B Glossary

3.1.6 corrosion, n-the chemical or electrochemical oxidation of the surface of metal which can result in loss of material or accumulation of deposits. E 270

3.1.7 debris, n-in internal combustion engines, solid contaminant materials unintentionally introduced into the engine or resulting from wear.

3.1.8 engine oil, n-a liquid that reduces friction or wear, or both, between the moving parts within an engine, and also serves as a coolant. D 4485

3.1.9 free piston ring, n-in internal combustion engines, a piston ring which will fall in its groove under the force of its own weight when the piston is moved from a vertical (axis orientation) to a horizontal position.
-In determining this condition, the ring may be touched slightly to overcome static friction.

3.1.10 hot-stuck piston ring, n-in internal combustion engines, a piston ring that is stuck when the piston and ring are at room temperature, and inspection shows that it was stuck during engine operation. Subcommittee B Glossary

3.1.11 lubricant, n-any material interposed between two surfaces that reduces the friction or wear, or both, between them.

3.1.12 noncompounded engine oil, n-a lubricating oil having a viscosity within the range of viscosities of oils normally used in engines, and that may contain anti-foam agents or pour depressants, or both, but not other additives. D 5119

3.1.13 non-reference oil, n-any oil other than a reference oil; such as a research formulation, commercial oil, or candidate oil. Subcommittee B Glossary

3.1.14 oxidation, n-of engine oil, the deterioration of the oil which is observed as increased viscosity, sludge formation, varnish formation, or a combination thereof, as a result of chemical and mechanical action. D 5119

3.1.15 reference oil, n-an oil of known performance characteristics, used as a basis for comparison. Subcommittee B Glossary

DISCUSSION-Reference oils are used to calibrate testing facilities, to compare the performance of other oils, or to evaluate other materials (such as seals) that interact with oils.

3.1.16 rust (coatings), n-the reddish material, primarily hydrated iron oxide, formed on iron or its alloys resulting from exposure to humid atmosphere or chemical attack. D 16

3.1.17 scoring, n-in tribology, a severe form of wear characterized by the formation of extensive grooves and scratches in the direction of sliding. G 40

3.1.18 scuffing, n-in lubrication, surface damage resulting from localized welding at the interface of rubbing surfaces with subsequent fracture in the proximity of the weld area. D 4175

3.1.19 sludge, n-in internal combustion engines, a deposit, principally composed of insoluble resins and oxidation products from fuel combustion and the lubricant, which does not drain from engine parts but can be removed by wiping with a cloth; see 3.1.18.

3.1.20 used oil, n-any oil that has been in a piece of equipment (for example, an engine, gearbox, transformer, or turbine), whether operated or not. D 4175

3.1.21 varnish, n-in internal combustion engines, a hard, dry, generally lustrous, deposit which can be removed by solvents but not by wiping with a cloth;

3.1.22 wear, n-the loss of material from, or relocation of material on, a surface. D 5302

DISCUSSION-Wear generally occurs between two surfaces moving relative to each other, and is the result of mechanical or chemical action, or of a combination of mechanical and chemical actions.

3.1.23 EOT time, n-end of test time, the end of test time will be twenty (20) minutes after the engine reaches 80 test hours of operation. This allows for the 90 second ramp down, the 15 minute wait for the oil to drain into the sump, and allows an operator 3.5 minutes to take the oil level.

3.2 Descriptions of Terms Specific to This Standard:

3.2.1 build-up oil, n-EF-411 noncompounded ISO VG 32 (SAE 20) oil used in lubricating the Sequence IIIF parts during engine assembly, and in coating parts following rating.

3.2.2 calibrated test stand, n-a test stand on which Sequence IIIF engine oil tests are conducted within the lubricant test monitoring system as administered by the ASTM TMC (see 11.1).

3.2.3 Central Parts Distributor (CPD), n-the manufacturer and supplier of many of the parts and fixtures used in this test method.

DISCUSSION-Because of the need for rigorous inspection and control of many of the parts used in this test method, and because of the need for careful manufacture of special parts and fixtures used, companies having the capabilities to provide the needed services have been selected as the official suppliers for the Sequence IIIF test method. These companies work closely with the original parts suppliers, with the Test Developer, and with the ASTM groups associated with the test method to help ensure that the equipment and materials used in the method function satisfactorily.

3.2.4 correction factor, n-a mathematical adjustment to a test result to compensate for industry-wide shifts in severity.

3.2.5 Special Test Parts (STP), n-parts that do not meet all the definitions of critical parts, non-production parts, or SPO parts, but must be obtained from the specified distributor.

3.2.6 critical parts (CP), n-those components used in the test, which are known to affect test severity.
-They must be obtained from the Central Parts Distributor or Special Parts Supplier, who will identify them with either a serial number or a batch lot control number.

3.2.7 EWMA, n-exponentially-weighted moving average.

3.2.8 Lubricant Test Monitoring System, LTMS, n-an analytical system in which ASTM calibration test data are used to manage lubricant test precision and severity (bias).

3.2.9 LTMS date, n-the date the test was completed unless a different date is assigned by the TMC.

3.2.10 LTMS time, n-the time the test was completed unless a different time is assigned by the TMC.

3.2.11 non-production parts (NP), n-these are components used in the test, which are available only through the Central Parts Distributor, Special Parts Supplier, or the Test Developer.

3.2.12 participating laboratory, n-a laboratory equipped to conduct Sequence IIIF tests, which conducts reference oil tests in cooperation with the ASTM TMC, in order to have calibrated test stands available for candidate oil testing.

3.2.13 quality index, n-a mathematical formula that uses data from controlled parameters to calculate a value indicative of control performance.

3.2.14 reference oil test, n-a standard Sequence IIIF engine oil test of a reference oil designated by the ASTM TMC.

3.2.15 SA, n-severity adjustment.

3.2.16 Service Parts Operations parts (SPO), n-these test components are obtained from Service Parts Operations a division of General Motors Corporation.

3.2.17 sluggish piston ring, n-one that is not free; it offers resistance to movement in its groove, but it can be pressed into or out of the groove under moderate finger pressure; when so moved, it does not spring back.

3.2.18 Special Parts Supplier, (SPS) n-the manufacturer and supplier of many of the parts and fixtures used in this test method.

3.2.19 Special Test Parts , n-parts that do not meet all the definitions of critical parts, non-production parts, or SPO parts, but must be obtained from the Special Parts Supplier.

3.2.20 standard test, n-an operationally-valid, full-length Sequence IIIF test conducted on a calibrated test stand in accordance with the conditions listed in this standard.

DISCUSSION-Such a test is also termed a valid test.

3.2.21 stuck lifter, n-a used lifter in which the plunger remains in a depressed position upon removal of the lifter from the engine, rather than being forced against the pushrod seat by the internal spring so that the pushrod seat bears against the lifter retainer clip.

3.2.22 stuck piston ring, n-one that is either partially or completely bound in its groove; it cannot be readily moved with moderate finger pressure.

3.2.23 Test Developer, n-the group or agency which developed the Sequence IIIF test method before its standardization by ASTM, and which continues to be involved with the test in respect to modifications in the test method, development of Information Letters, supply of test parts, etc.

DISCUSSION-As defined in Committee D02.B0.08 Regulations Governing the American Society for Testing and Materials Test Monitoring System, "`Test Developer' shall refer to those individual companies which have developed and/or are responsible for supplying the basic hardware for the tests referred to in Paragraph 2.1 (Article 2-Purpose of the Test Monitoring System)." In the case of the Sequence IIIF test, the Test Developer is General Motors Research and Development Center.

3.2.24 test full mark, n-the oil level established after the ten (10) minute initial run-in.

3.2.25 test oil, n-an oil subjected to a Sequence IIIF engine oil test.

DISCUSSION-It can be any oil selected by the laboratory conducting the test. It could be an experimental product or a commercially-available oil. Often, it is an oil which is a candidate for approval against engine oil specifications (such as manufacturers' or military specifications, etc.).

3.2.26 test stand, n-a suitable foundation (such as a bedplate) to which is mounted a dynamometer, and which is equipped with a suitable data acquisition system, fluids process control system, supplies of electricity, compressed air, etc., to provide a means for mounting and operating an engine in order to conduct a Sequence IIIF engine oil test.

3.2.27 test start, n-introduction of test oil into the engine after the final assembly and mounting in the test stand.

4. Summary of Test Method

4.1 A 3800 Series II 3.8L (231-in.³) V-6 test engine block is solvent-cleaned, measured, and rebuilt; using new parts installed as specified in this test method.

4.2 The engine is installed on a test stand equipped with the appropriate data acquisition system, the required fluids process control system and all necessary accessories for controlling speed, load, and various other operating parameters.

4.3 The engine is charged with the test oil.

4.4 The engine is operated for a 10 min initial run-in period to check all test stand operating systems and to establish a zero hour oil level reading and initial oil viscosity sample.

4.5 Following the 10 min initial run-in and oil level, the engine is operated under non-cyclic, moderately high speed, load, and temperature conditions for 80-h, in 10-h segments.

4.6 The initial oil level in the oil pan is determined after the 10-min initial run-in, and subsequent oil level calculations are determined during the oil leveling period at the end of each 10-h segment.

4.7 Used oil samples are taken after the 10-min initial run-in and after each 10-h test segment; kinematic viscosity at 40°C (104°F) is determined for each of the ten samples; the percentage change in viscosity of the nine latter samples is determined relative to the viscosity of the first used oil sample (10-min initial run-in).

4.8 At the conclusion of the test, the engine is disassembled and the parts are visually rated to determine the extent of deposits formed. In addition, wear measurements and visual inspections are obtained for the critical valve train components.

5. Significance and Use

5.1 This test method was developed to evaluate automotive engine oils for protection against oil thickening and engine wear during moderately high-speed, high-temperature service.

5.2 The increase in oil viscosity obtained in this test indicates the tendency of an oil to thicken because of oxidation. In automotive service, such thickening can cause oil pump starvation and resultant catastrophic engine failures.

5.3 The deposit ratings for an oil indicate the tendency for the formation of deposits throughout the engine, including those which can cause sticking of the piston rings in their grooves, and the sticking of plungers in hydraulic valve lifters. The former can be involved in the loss of compression pressures in the engine, and the latter is related to valve train noise and wear.

5.4 The camshaft and lifter wear values obtained in this test provide a measure of the anti-wear quality of an oil under conditions of high unit pressure mechanical contact.

5.5 The test method was developed to correlate with oils of known good and poor protection against oil thickening and engine wear. Specially formulated oils that produce less than desirable results with unleaded fuels were also used during the development of this test.

5.6 The Sequence IIIF engine oil test is expected to replace the Sequence IIIE test and planned to be used in specifications and classifications of engine lubricating oils, such as the following:

5.6.1 Specification D 4485,

5.6.2 Military Specification MIL-L-2104, and

5.6.3 SAE Classification J183.

6. Apparatus

6.1 Laboratory-Observe the following laboratory conditions to ensure good control of test operations, and good repeatability:

6.1.1 Maintain the ambient laboratory atmosphere relatively free of dirt, dust, and other contaminants.

6.1.2 Control the temperature of the room in which parts measurements are made so that the temperature for after-test measurements is within a range of $\pm 3^{\circ}\text{C}$ ($\pm 5^{\circ}\text{F}$) relative to the temperature for the before-test measurements. If difficulties with parts fits are encountered, consider the effects of temperature coefficient of expansion. See 6.2.

6.1.3 Filter the air in the engine build-up area, and control its temperature and humidity to prevent accumulation of dirt or rust on engine parts.

6.1.4 If an engine is assembled in an area of controlled environment and moved to a non-controlled area, provide suitable protection of the engine so that moist air cannot enter the engine and promote rusting before the test.

6.1.5 Do not permit air from fans or ventilation systems to blow directly on an engine mounted on a test stand during test operation.

6.2 Drawings-Obtain the equipment drawings referenced in Annex A3 of this test method from the ASTM TMC. Because the drawings may not be to scale, or may not contain dimensions, when using them to fabricate special parts, do not use a dimensionless drawing as a pattern. Drawings supplied with dimensions are considered to be correct when the temperature of the equipment is 22°C (72°F), unless otherwise specified.

6.3 Specified Equipment-Use the equipment specified in the procedure whenever possible. Substitution of equivalent equipment is allowed, but only after equivalency has been proven to the satisfaction of the ASTM TMC, the Test Developer, and the ASTM Sequence IIIF Surveillance Panel.

6.3.1 Do not use heat lamps or fans directed at the engine, and do not use insulation on the engine, for temperature control.

DISCUSSION-For operator safety and the protection of test components, the use of shielding and insulation on the exhaust system may be incorporated downstream of the oxygen sensor elbow.

6.4 Test Engine-The test engine is based on a 1996-97 L36 3800 Series II 3.8L (231-in.³) V-6 engine with an 9.0:1 compression

ratio, equipped with a production fuel injection system, a retrofit flat tappet valvetrain, and a special powertrain control module (PCM) for test specific dynamometer operation. Rebuild the engine as specified in this test method.

6.4.1 Engine Parts-Use the engine parts specified in the Sequence IIIIF Engine Assembly Manual.

6.4.1.1 Use all engine parts as received from the supplier, Central Parts Distributor, Special Parts Supplier, or original equipment manufacturer, unless modifications are specified in this test method or the Sequence IIIIF Engine Assembly Manual.

6.4.1.2 Do not divert to other applications, any parts obtained for use in Sequence IIIIF testing.

6.4.1.3 Before disposing of Sequence IIIIF engine parts, render them useless for automotive engine applications.

6.5 Engine Speed and Load Control-Use dynamometer speed and load control systems which are capable of controlling the speed and load as specified in Section 11 of this procedure under Data Acquisition and Control.

6.6 Sequence IIIIF Fluid Conditioning Module -Use the Kundinger Fluid Conditioning Module to control the following parameters: engine coolant, breather tube coolant, oil cooler coolant, exhaust manifold coolant, and the test fuel supply. The system incorporates the following features: pumps, flow meters, flow control and three-way control valves, external heating and cooling systems, pressure regulator and low-point drains. The system integrates with the test stand data acquisition and control computer for process control.

6.6.1 Engine Cooling System-Contained in the Fluid Conditioning Module, supplies non-pressurized coolant at a flow rate of 160 L/min (42.3 gal/min) temperature controlled at 122°C (251.6°F) at the engine coolant outlet. The system incorporates the following features: pump, vortex-type flow meter, flow control and three-way control valves, external heating and cooling systems, and low-point drains. The system integrates with the test stand data acquisition and control computer for process control and maintains the specified engine coolant temperature and flow. The system should be flushed with clean water at least once each reference period.

6.7 Flushing Tank-Use a flushing tank such as that shown in drawings RX-116924-C, RX-117230-E, and RX-117231-C to circulate the cleaning agents. Use plumbing materials which are impervious

to the acidic cleaning agents (stainless steel has been found satisfactory).

6.8 Coolant Mixing Tank-Use a mixing tank such as that shown in drawing RX-117350-D to premix the engine coolant.

6.9 Breather Tube Cooling System- Contained in the Fluid Conditioning Module, supplies non-pressurized coolant at a flow rate of 10 L/min (2.64 gal/min) temperature controlled at 40°C (104°F) at the breather tube outlet. The system incorporates the following features: breather tube heat exchanger, ITT 5-142-08-036-001^{xx}: breather tube adapter fitting, pump, magnetic-type flow meter, flow control and three-way control valves, external heating and cooling systems, and low-point drains. The system integrates with the test stand data acquisition and control computer for process control and maintains the specified coolant temperature and flow.

6.10 Engine Oil-Cooling System- The system consists of an oil filter adapter, fitting adapter, oil cooler, and gaskets specified in the Sequence IIIF Engine Assembly Manual (section 8 sheet 3). The system uses engine coolant provided through the Fluid Conditioning Module at a flow rate of 12.0 L/min (3.17 gal/min) through a three way valve as necessary to control the engine oil temperature. When testing high oxidation sensitive reference oils, the oil filter adapter may go into a by-pass mode, which causes the oil cooler to be by-passed. In this condition the TMC may allow engineering judgement for the oil temperature Quality Index.

6.10.1 Replace the oil cooler after every test.

6.10.2 Do not use cuprous lines or fittings in the oil-cooling system.

6.10.3 Do not use magnetic plugs in the oil system.

6.10.4 Use suitable hose and fittings when plumbing the oil-cooling system.

6.11 Fuel System- Contained in the Fluid Conditioning Module, a pressurized, recirculating fuel system, including a pressure regulator to provide 365 kPa (52.94 ± 1 psi) fuel pressure. The system should be switched off so no fuel pressure is present at the injector rail during engine shutdowns.

6.12 Induction Air Supply Humidity, Temperature, and Pressure- Maintain the throttle body intake air at a moisture content of 11.4 ± 0.7 g/kg (80.0 ± 5 grains/lb.) of dry air, a dry bulb temperature of 27°C (80.6°F), and a static pressure of 0.050 kPa

(0.2 in. of water). Temperature and pressure shall be measured at the inlet air adapter.

6.13 Temperature Measurement-Use 1/8 in iron-constantan (Type J) thermocouples for temperature measurement.

6.13.1 Thermocouple Location-Locate the sensing tip of all thermocouples in the center of the stream of the medium involved, unless otherwise specified.

6.13.1.1 Oil Filter Adapter-Install the thermocouple in the tapped hole in the oil filter adapter, as shown in the Sequence IIIF Engine Assembly Manual section 8 sheet 3.

6.13.1.2 Oil Pan (Sump)-Install the thermocouple in the oil sump drain plug OHT3F-063-1 with the tip extending 19 to 25 mm (0.75 to 1.0 in.).

6.13.1.3 Engine Coolant In-Install the thermocouple in the coolant inlet adapter OHT3F-031-1 with the sensing tip centered in the coolant flow.

6.13.1.4 Engine Coolant Out-Install the thermocouple for the coolant outlet OHT3F-034-1 with the sensing tip centered in the coolant flow.

6.13.1.5 Breather Tube Coolant Out-Locate the thermocouple in the coolant-out fitting in the breather tube with the sensing tip centered in the coolant flow.

6.13.1.6 Blowby Gas-Install the thermocouple at the outlet of the breather tube with the sensing tip centered in the blowby gas flow.

6.13.1.7 Fuel-Install the thermocouple in the fuel rail fittings on the inlet side of the fuel rail.

6.13.1.8 Inlet Air-Install the thermocouple in the inlet air adapter as shown in the Sequence IIIF Engine Assembly Manual section 8 sheet 3.

6.14 Air-to-Fuel Ratio Determination-Determine the engine air-to-fuel ratio by measuring the CO, CO₂, and O₂ components of the exhaust gas sample with electronic exhaust gas analysis equipment. When using electronic exhaust gas analyzers, take particular care to ensure that the exhaust gas sample is dried prior to introducing it to the analyzer. Take the exhaust gas samples from the inboard holes of the exhaust manifold exit flanges. See Annex A7

6.14.1 Injector Flow Testing-Flow test the fuel injectors before each test according to the following procedure:

6.14.1.1 Stoddard solvent should be used as the calibration fluid.

6.14.1.2 Apply 40 psi to the fuel rail.

6.14.1.3 Apply 13 volts to the injector solenoid continuously.

6.14.1.4 Allow the injector to spray into a graduated cylinder that is capable of holding at least 250 ml.

6.14.1.5 All injectors should be volume checked for 60 seconds. Note the volume that each injector produces.

6.14.1.6 Observe the spray pattern that each injector produces. If the injector has a straight stream or dribbles, it should be discarded.

6.14.1.7 When installing the injectors on the fuel rail it is important that the six injectors that are installed on an engine produce volumes which are within 5 ml of each other.

6.14.2 It is recommended that the injector be flushed with test fuel to remove the solvent that is remaining in it from the flow check. If this is not done, it could affect the engine initial start up (require more cranking).

6.15 Exhaust and Exhaust Back Pressure Systems:

6.15.1 Exhaust Manifolds and Pipes-Install water-cooled exhaust manifolds and stainless runners as shown in the Sequence IIIF Engine Assembly Manual section 8.

6.15.2 Water-Jacketed Exhaust Pipes- For safety reasons, water jacketed exhaust pipes or external water spray systems are allowed only when introduced beyond the "Y" pipe and after the system drops below the bedplate or enters the overhead loft.

6.15.3 Exhaust Sample Lines-Install exhaust sample lines at the inboard holes of the two exhaust manifold exit flanges. Use good laboratory practice to ensure that water does not accumulate in the lines during engine operation.

6.15.4 Back-Pressure Lines-To permit measurement of the back pressure in each exhaust manifold, install exhaust back-pressure lines in the outboard holes of the exhaust manifold exit flanges. Use good laboratory practice to ensure that water does not accumulate in the lines during engine operation.

6.16 Blowby Flow Rate Measurement-Use the sharp-edge orifice meter to measure engine blowby flow rates. See section 12

6.17 Pressure Measurement and Pressure Sensor Location-Use electronic pressure transducers located as indicated in the Sequence IIIF Engine Assembly Manual.

6.17.1 Intake Manifold Vacuum-Use a transducer having a range of 0 to 100 kPa (0 to 20 in. Hg). Connect the transducer to the vacuum outlet located on the intake plenum main vacuum port. Tee the transducer, manifold air pressure sensor and fuel rail pressure regulator all together from the main port.

6.17.2 Engine Oil Gallery Pressure- Use a transducer having a range of 0 to 700 kPa (0 to 100 psi). Connect the gage to the location shown in the Sequence IIIF Engine Assembly Manual section 8 sheet 3 (OUT Port, oil to block).

6.17.3 Oil Pump Outlet Pressure- Use a transducer having a range of 0 to 700 kPa (0 to 100 psi). Connect the transducer to the location shown in the Sequence IIIF Engine Assembly Manual section 8 sheet 3 (IN Port, oil to filter).

6.17.4 Exhaust Back Pressure- Use a transducer having a range of 0 to 10 kPa (0 to 40 in. of water) attach the line to the outboard fitting on the exhaust end plate as shown in the Sequence IIIF Engine Assembly Manual section 8 sheet 1.

6.17.5 Inlet Air Pressure- Use a transducer having a range of 125 Pa (0.5 in. of water). Connect the transducer to the air inlet adapter as shown in the Sequence IIIF Engine Assembly Manual section 8 sheet 4.

6.17.6 Crankcase Pressure- Use a transducer having a range of -125 to +125 Pa (-0.5 to +0.5 in. of water). Connect the transducer to the front of the lower intake manifold as shown in the Sequence IIIF Engine Assembly Manual section 6 sheet 7.

6.18 PCV Plug- The positive crankcase ventilation system is blocked off during testing using a dummy PCV valve as shown in the Sequence IIIF Engine Assembly Manual section 6 sheet 11.

6.19 Parts Modifications- Modify the following parts according to the instructions listed in the Sequence IIIF Engine Assembly Manual:

- 6.19.1 Throttle body, section 6 sheet 9.
- 6.19.2 Intake manifold, section 6 sheet 7.
- 6.19.3 Engine block, section 1 sheet 2.

7. Reagents and Materials

7.1 Test Fuel-Use only EEE unleaded fuel ^{xx} (Warning-see Note 4) (see Annex A4, Table xx), observing the following:

Note-4: Warning-Flammable. Health Hazard.

7.1.1 Make certain that all tanks used for transportation and storage are clean before they are filled with test fuel.

7.1.2 Verify that at least 2000 L (526.3 gal) of test fuel (Warning-see Note 5) is available for use before initiating a test.

Note-5: Warning-Flammable. Health Hazard.

7.2 Additive Concentrate for the Coolant Blend the additive concentrate for the engine coolant system, and for the breather tube coolant system, using ethylene glycol meeting ASTM Standard Specification E1119-92 for Industrial Grade Ethylene Glycol^{xx} (Warning--see Note 6) plus the coolant additive^{xx} at a concentration of 15.625 mL/L (0.125 pt/gal) (Warning--see Note 7).

^{xx} Ethylene Glycol meeting this specification is available from Dow Chemical Co., 2040 Dow Center, Midland, MI 48674. An equivalent may be used.

Note-6: Warning-Combustible. Health Hazard.

Note-7: Warning-See the appropriate materials safety data sheet.

7.3 Coolant Preparation-Prepare the coolant blend for the engine coolant system, and for the oil cooler and breather tube coolant system, in the following manner:

7.3.1 Do not apply heat either during, or following, the coolant preparation.

7.3.2 Use a container of a size adequate to hold the entire coolant blend required by both systems. See drawing RX-117350-D for an example of a suitable container.

7.3.3 Add the required amount of glycol (Warning-see Note 8) to the container.

Note-8: Warning-Combustible. Health Hazard.

7.3.4 Add the required amount of additive concentrate to the container.

7.3.5 Agitate the blend in the container for 30 min.

7.3.6 Within 2 hours, add the blend to the engine coolant system, and to the oil cooler and breather coolant system.

7.4 Pre-Test Cleaning Materials-Use the cleaning materials (see Note 9) specified in the following list for cleaning of parts to be used in the test. Use no substitutes (see Note 10).

7.4.1 Commercial cleaning agent^{xx} (Warning-see Note 11)

^{xx} An acceptable cleaning agent is Penmul L460 available from the Penetone Corporation 74 Hudson Ave. Tenafly, New Jersey 07670.

7.4.3 Aliphatic naphtha meeting Specification D 235 Type I regular mineral spirits (Stoddard solvent) requirements, with a boiling point of 149-204°C (300-400°F) ^{xx} (see Note 9, 12, & 13).

7.4.4 Sequence IIIF test component cleaner,^{xx} a mixture (by mass) of:

94 parts oxalic acid^{xx1} (Warning-see Note 14).

6 parts dispersant^{xx2} (Warning-see Note 14).

^{xx1} Oxalic acid (55-lb bags) and sodium carbonate (50-lb bags) are available from Ashland Chemical Co., P.O. Box 391, Ashland, KY. 41114. If permitted by the hazardous materials disposal practices in a laboratory, sodium carbonate can be used to neutralize the oxalic acid in used Sequence IIIF Test component cleaner.

^{xx2} Petro Dispersant Number 425 Powder (50-lb bags) is available from Witco Corp., 3230 Brookfield, Huston, TX. 77045.

Note-9: Warning-See the appropriate materials safety data sheet.

Note 10-Only these specific materials and sources have been found satisfactory. If chemicals other than these are proposed for use, equivalency must be proven and approval obtained from the ASTM TMC.

Note 11: Warning-Corrosive. Health Hazard.

Note 12: Warning-Flammable. Health Hazard.

Note 13: Warning-Combustible. Health Hazard.

Note 14: Warning-Corrosive. Health Hazard.

7.5 Sealing and Anti-seize Compounds-Use the sealing and anti-seize compounds specified in the following list. See Notes 16 and 17.

7.5.1 Sealing compound for the cylinder head bolts,^{xx3}

^{xx3} Permatex Number 2 non-hardening sealer available through local distributors of Permatex products.

7.5.2 Sealing compound for front and rear cover gaskets ^{xx4}

^{xx4} Perfect Seal Number 4 Brush-Type Sealing Compound, part GM3D (16oz container), must be used. It can be ordered from P.O.B. Sealants Inc., 11102 Kenwood Rd. Cincinnati, OH. 45242

7.5.3 Anti-seize compound for the exhaust manifold and pipe bolts,^{xx5}

^{xx5} Anti-seize compounds which have been found suitable are Fel-Pro C-100 available from Fel-Pro Inc. and Permatex anti-seize compound part no. 80078 brush top container. Both products should be available through local distributors.

Note 16-Warning-See the appropriate materials safety data sheet.

Note 17-Only the specific materials and sources indicated in 7.5 have been found satisfactory. If materials other than these are proposed for use, equivalency must be proven and approval obtained from the ASTM TMC.

8. Hazards

8.1 General-The environment involved with any engine test is inherently hazardous. Serious injury of personnel and damage to facilities can occur if adequate safety precautions are not taken. However, as evidenced by the fact that many thousands of engine tests are successfully conducted each year, it is possible to take adequate precautions.

8.2 Caveat-The following paragraphs do not cover all possible safety-related problems associated with Sequence IIIIF testing. See 1.3.

8.3 Personnel-Carefully select and train personnel who will be responsible for the design, installation, and operation of Sequence IIIIF test stands. Make certain that the test operators are capable of handling the tools and facilities involved, and in observing all safety precautions, including avoiding contact with either moving or hot test parts.

8.4 Personnel Protection Facilities-Provide the following personnel protection facilities:

8.4.1 Provide safety shower and eye-rinse equipment in close proximity to the facilities used for parts cleaning, engine build-up, engine test operation, and parts rating.

8.4.2 Provide, and require the use of, appropriate face masks, eye protection, chemical breathers, gloves, etc. in all aspects of Sequence IIIIF testing.

8.4.3 Provide dry chemical fire extinguishers for putting out fires.

8.4.4 Advise personnel not to use water to attempt to extinguish fires involving fuel, oil, or glycol.

8.4.5 Equip test stands with automatic fire extinguishing equipment.

8.4.6 Install suitable guards around all external moving parts, or hot parts.

8.4.7 Advise personnel not to work alongside the engine and coupling shaft when the engine is operating at high speeds.

8.4.8 Provide barrier protection between the engine and coupling shaft, and operating personnel.

8.4.9 Prohibit the wearing of loose or flowing clothing by personnel working near a running engine.

8.4.10 Advise personnel regarding the possibility of exothermic reactions with some of the chemicals used in the Sequence IIIF test.

8.5 Safety Equipment and Practices-Observe the following in order to establish and maintain safe working conditions for Sequence IIIF testing:

8.5.1 Provide the proper tools for conducting the Sequence IIIF test.

8.5.2 Require regular inspection and approval by the laboratory safety department of the facilities used for Sequence IIIF testing.

8.5.3 Properly install all fuel lines, coolant lines, oil lines, air lines, and electrical wiring; and maintain them in good condition.

8.5.4 Select and install coolant hoses and clamps with special care in order to prevent coolant leaks and possible fires.

8.5.5 Do not permit tripping hazards to exist in any of the areas involved with the Sequence IIIF testing.

8.5.6 Keep the outer surfaces of the engine, other equipment, and the floor area free of fuel and oil.

8.5.7 Do not allow the accumulation of containers of oil or fuel in Sequence IIIF test areas.

8.5.8 Demand that personnel be alert for leaking fuel, exhaust gas, oil, or coolant, and that they take action to stop such leaks.

8.5.9 Equip the test stand with an automatic fuel shutoff valve designed to turn off the fuel supply to the engine whenever the engine is not running.

8.5.10 Make provision for manual, remote operation of the fuel shutoff valve.

8.5.11 Install suitable interlocks to shut down the engine when any of the following develop: loss of dynamometer field current, engine overspeeding, loss of engine oil pressure, failure of the exhaust system, failure of the room ventilation, activation of the fire protection system, excessive vibration, etc.

8.5.12 In case of injury, seek medical attention immediately, and report the incident to the proper administrative people.

9. Test Oil Sample Requirements

9.1 Selection-The supplier of the test oil sample shall determine that it is representative of the lubricant formulation being evaluated and that it is not contaminated.

9.2 Quantity-The supplier should provide 15 L (4 gal) of the test oil sample.

Note-18 A Sequence IIIF Test can be conducted with only 12 L (3.17 gal) of test oil, provided that no spillage or leakage occurs during test preparation. The greater quantity is specified to accommodate such spillage and leakage.

9.3 Storage Prior to Test-The test laboratory shall store the test oil sample in a covered building to prevent contamination by rainwater.

10. Preparation of Apparatus

10.1 Breather Tube Cleaning-Immediately after completing a Sequence IIIF test, remove the stainless steel breather tube assembly, disassemble it, and soak it in commercial cleaning agent. (Warning-see Note 19) After the soaking, clean the inside of the tube with commercial cleaning agent (Warning-see Note 20) and a non-cuprous bristle brush.⁵⁷ Rinse both the blowby gas and coolant sides of the breather tube with clean aliphatic naphtha. (Warning-see Note 21)

Note-19: Warning-Corrosive. Health Hazard.

Note 20: Warning-**Blank**

Note 21: Warning-Combustible. Health Hazard.

10.1.1 After ten tests, or more frequently if film is present, clean the coolant side of the breather tube by flushing it for ½ hour with a water solution of 20 g/L of Sequence IIIF test component cleaner (Warning-see Note 22) (see 7.4). Rinse it thoroughly with tap water at 60°C (140°F).

Note-22: Warning-Corrosive. Health Hazard.

10.1.2 After cleaning the coolant side of the breather tube, pressure check it with air at 70 kPa (10 psi) (Warning-see Note 23).

Note-23: Warning-For technical use only.

10.3 Intake Manifold Cleaning-Clean the intake manifold to ensure proper heat transfer rates. Wire brush the side exposed to the lifter valley, and thoroughly wash it with commercial cleaning agent (Warning-see Note 24) and aliphatic naphtha. (Warning-see Note 25)

Note-24: Warning-Corrosive. Health Hazard.

Note 25: Warning-Combustible. Health Hazard.

10.4 Cleaning of Engine Parts (other than the block and heads)- Clean all engine parts (other than the block and heads; see 10.5 and 10.6) thoroughly prior to engine assembly. Degrease them first, and then brush them with commercial cleaning agent. (Warning-see Note 26) (Prevent contact by the cleaner of nonferrous parts.) Immediately remove the cleaner by spraying with aliphatic naphtha. (Warning-see Note 27) Blow dry the parts with clean, dry shop air (Warning-see Note 28), and immediately coat them with build-up oil.^{xx}

Note-26: Warning-Corrosive. Health Hazard.

Note 27: Warning-Combustible. Health Hazard.

Note 28: Warning-For technical use only.

10.5 Engine Block Cleaning-Clean the block according to the following:

10.5.1 If a new block is used, remove the debris in all tapped holes using bottoming taps of the appropriate sizes.

10.5.2 Physically remove all sand and slag deposits, and any other debris, from the water jacket using a sharp-ended drill rod or a long straight slot screwdriver.

10.5.2.1 Check the camshaft tunnel for sharp edges on the front of each bore and along the cross-drilled oil gallery inside each bearing bore. See the Sequence IIIF Engine Assembly Manual section 1 sheet 2.

10.5.3 Thoroughly clean the block prior to honing as follows: In the case of a block used in a previous test, remove the crankshaft, main bearings, and bearing caps. In addition, all bushings, bearings, and oil gallery plugs shall be removed prior to cleaning. With either a new or used block, prevent cleaner or oil from entering the engine coolant passages. Clean the block by applying commercial cleaning agent to the cylinder walls and other areas; do not submerge the block in the commercial cleaning agent. (Warning-see Note 29) The cleaning solution may be circulated through the oil passages to ensure removal of deposits. Remove the cleaner by spraying the block (including all oil galleries) with aliphatic naphtha. (Warning-see Note 30) Blow dry with air. (Warning-see Note 31)

Note-29: Warning-Corrosive. Health Hazard.

Note 30: Warning-Combustible. Health Hazard.

Note 31: Warning-For technical use only.

10.5.3.1 The block should be cleaned in a heated bath or temperature controlled automated parts washer before and after

honing. Follow the suggested guidelines as listed below to ensure there is no oxidation flash over of the engine block after this process.

- 1) Use only NAT-50-S soap at a concentration of 16 pounds of soap per 100 gallons of water.
- 2) Set the temperature of the water to 140 degrees F.
- 3) Do not pre-condition the water that is being used in any way.
- 4) Prior to installing the engine in the parts washer, ensure that all coolant passages are blocked off to prevent cleaning solutions from entering the passages.
- 5) Allow the block to run through the cleaning cycle for a period of 30 to 40 minutes.
- 6) After the cycle is complete, immediately remove the block from the washer and spray it down with stoddard solvent.
- 7) Wipe cylinder bores out with a lint free towel.
- 8) Spray engine block with a mixture of 50/50 EF-411 and stoddard solvent.

10.5.3.2 See the Sequence IIIF Engine Assembly Manual section 2 for the honing procedure.

10.5.3.3 After the cylinder walls have been honed, clean the engine block again according to 10.5.3. and spray the engine block (including all oil galleries) first with aliphatic naphtha (Warning-see Note 32) followed by a 50:50 mixture of aliphatic naphtha and build-up oil. Using this 50:50 mixture, wipe out the cylinder bores with clean cloth towels until all honing residue has been removed.

Note-32: Warning-Combustible. Health Hazard.

10.5.3.4 Air dry the engine block, using clean dry shop air (Warning-see Note 33), and coat the cylinder walls with build-up oil using soft, lint-free, clean cloths.

Note-33: Warning-For technical use only.

10.6 Cylinder Head Cleaning-Clean the cylinder heads according to the following:

10.6.1 Using a flexible probe, explore all accessible water passages to detect any material which would interfere with coolant flow.

10.6.2 Using a 10-mm wire brush, extending two-thirds the length of the cylinder head from freeze plug hole to freeze plug hole, clean all core sand and casting slag from the cylinder heads to ensure unrestrained coolant flow.

10.6.3 Clean the cylinder heads according to the recommended engine block cleaning procedure (10.5).

10.6.4 Air dry the cylinder heads using clean dry shop air. (Warning-see Note 34)

Note-34: Warning-For technical use only.

10.7 Engine Build-up Procedure-Laboratories should design and maintain engine build data sheets in a format compatible with Excel and record data for cylinder bore measurements, piston and ring sizing data, valvetrain spring load calibrations, camshaft and lifter measurements, and all critical part identification information. This data shall be made available to the TMC and the Test Developer for investigative studies as deemed necessary for hardware investigations during times of industry severity shifts or other problems.

10.7.1 General Information-Use only the listed service parts, special test parts, and special build-up procedures specific to this test as outlined in this procedure and the Sequence IIIF Engine Assembly Manual. See 6.4. Make and record measurements specified in this test method, of the cylinders, pistons, rings, bearings, valve train, cam, and lifters. These measurements will provide evidence of conformance to the specifications of the method, and will provide baselines for determining engine wear which occurs during a Sequence IIIF test.

10.7.2 Special Parts-Use the special parts listed in the Sequence IIIF Engine Assembly Manual sections 9, 10, and 11.

10.7.3 Hardware Information-Complete Form 12, Hardware Information, in standardized report form set (See Annex A6).

10.7.5 Fastener Torque Specifications and Torquing Procedures-Use the following specifications and torquing procedures when installing bolts in the engine:

10.7.5.1 Main Bearing Cap Bolts- Do not use air tools on bolts to seat the main bearing caps in the engine block. Use a rubber or plastic mallet to seat the main bearing caps to avoid

misalignment and potential damage to the engine block. Apply build-up oil to the threads, and to the surfaces of the bolts which contact the main bearing caps. In order to prevent hydraulic lock, do not apply oil to the tapped holes in the cylinder block. Install the bolts finger tight, and tighten them further with the SPS Torque Sensor I torque wrench^{xx} only working from the center out in a criss cross pattern. See the Sequence IIIF Engine Assembly Manual for torquing instructions. (See section 1 sheet 6 for honing and section 3 sheet 6 for final assembly)

10.7.5.2 Cylinder Head Bolts-The cylinder head bolts, GM Part No. 25527831 (long) and 25533811 (short), are of special design for yield applications and shall be installed using the SPS Torque Sensor I torque wrench^{xx} only. See the Sequence IIIF Engine Assembly Manual for installation instructions. Replace the bolts after each test. (See section 1 sheet 7 for honing and section 5 sheet 3 for final assembly)

10.7.5.4 Torques for Miscellaneous Bolts, Studs, and Nuts-Use the torques for miscellaneous bolts, studs, and nuts given in the Sequence IIIF Engine Assembly Manual.

10.8 Parts Replacement-See 10.7.1 for information regarding parts. Replace test parts as follows:

10.8.1 Install the new parts listed in Annex A2 Table 1 for each test.

10.8.2 Install the new parts listed in Annex A2 Table 2, only if the used part is no longer suitable for test purposes.

10.9 Engine Block Preparation-Prepare the engine block as follows:

10.9.1 Install new engine block freeze plugs; use a driver to facilitate this replacement.

10.9.2 Install the main bearing caps, without the bearings in place. Tighten the retaining bolts using the procedure in 10.7.5.1.

10.9.3 To prevent entry of honing fluid into the coolant passages of the engine block, cover and seal the coolant inlet passages and freeze plug openings. Close the petcocks, if any were previously installed; if not, install 1/4-in. NPT pipe plugs

10.9.4 Using a 30-cm (12-in.) smooth file, deburr the surfaces of the block which mate with the cylinder heads to ensure adequate gasket seating.

10.9.5 The honing torque plates B-H-J GM 3.8L/3E-R-s_t-HT^{xx} shall be used with the proper hardened washers, supplied with the honing torque plates, single washers on top row and double washers on bottom row to establish proper bolt depth to pre-stress the engine block for honing. Clean the threaded bores for the cylinder head attachment bolts using a bottoming tap before each installation of the torque plates. The torque plates require the use of new head gaskets, SPO Part No. 24503801 left and 24503802 right, along with cylinder head torque-to-yield fasteners, SPO Part No. 25527831 (long). Clean all sealing and thread locking compounds from the fasteners for the torque plate installation. Coat each fastener with build-up oil and see the Sequence IIIF Engine Assembly Manual for installation instructions. (See section 1 sheet 7)

10.9.6 Use only the CV616 honing machine^{xx} to hone the cylinder walls. See the Sequence IIIF Engine Assembly Manual section 2 for all of the proper setup and operational procedures for each specific run on the Sequence IIIF engine block.

10.9.7 Replace the honing fluid, filters, and fiber mats used in the honing machine every 15-h of honing machine operation. Use the honing machine hour meter to determine hours of operation.

10.9.9 The flow rate of the honing lubricant should be approximately 7.6 L/min (2 gal/min). The honing fluid should not contain an excessive amount of honing debris. In addition, no solvents are to be introduced into the honing fluid or used to clean the honing stones or guides. Only honing fluid is permitted to clean honing stones or guides.

10.9.11 Hone the cylinder walls without the main bearings in place, but with all bearing caps installed

10.9.12 Clean the engine block following honing according to 10.5.

10.9.13 Check the main bearing bore clearances using a mandrel, part BX-398-1, according to the following procedure:

Starting from the front of the block, slide the mandrel through all four main bearing bores. If excessive resistance is encountered while inserting the mandrel, remove the mandrel from the engine block and inspect the main bearing bores for burrs, nicks, dirt, alignment problems, or any abnormalities. Use 400 grit paper or a fine stone to carefully remove any nicks, burrs, scratches, or dirt. Then use a clean shop towel with aliphatic naphtha to wipe the affected surfaces. Reinstall the mandrel to ensure that it can freely pass through all four main bearing

bores. If the mandrel will not clear the bores after the above steps have been completed, the block should not be used. Notify the Test Developer of the problem. After honing, the above procedure should be repeated prior to final engine build. The mandrel is an alignment and clearance gage only, not an assembly tool. The mandrel should not be in the bores when installing the main bearing caps or torquing the main bearing bolts.

10.10 Piston Fitting and Numbering-Fit the pistons to the cylinders according to recommendations listed in the engine assembly manual for the run sequence of the block. Use only the specified code pistons for each run sequence. Number the pistons with odd numbers in the left bank from front to rear and with even numbers in the right bank from front to rear.

10.10.1 Piston Rings- The rings are pre-sized for each run and the gap must be checked in the cylinder bore for each test. The top ring must be 0.102 mm (0.004 in.) larger gap than the second ring. The piston ring gaps should be set at 1.067 mm \pm 0.0254 mm (0.042 in. \pm 0.001 in.) top and 0.965 mm \pm 0.0254 mm (0.038 in. \pm 0.001 in.) second ring gap. Check the ring gap with a ring gap feeler gage^{xx} with the ring positioned in the cylinder bore using a piston ring depth gage (drawing RX-118602-B). Rings shall be positioned at 23.67 mm (0.932 in.) below the cylinder block deck surface during gap measurement. Record the top and bottom ring gaps on Form 12, Hardware Information, in standardized report form set (See Annex A6). Ring gaps shall be recorded and reported in mils (1 mil = 0.001 in).

10.11 Pre-Test Camshaft and Lifter Measurements-Measure the camshaft lobe height and lifter lengths, prior to engine assembly, according to the following procedure:

Note-35 When these parts are removed from the packages as received from the supplier, and if they are not to be measured and installed in the engine immediately, coat them with build-up oil.

10.11.1 If necessary, remove any burrs on the open end of the hydraulic valve lifters, Part OHT3F-029-3 using 400-grit emery paper.

10.11.2 With the camshaft positioned in a set of V-Blocks, Remove any burrs around the camshaft thrust surface. See the Sequence IIIF Engine Assembly Manual section 3 sheet 11 for detailed instructions.

10.11.3 Clean the camshaft with aliphatic naphtha (Warning-see Note 36); blow dry them with clean, dry shop air. (Warning-see Note 37)

Note-36: Warning-Combustible. Health Hazard.

Note-37: Warning-For technical use only.

10.11.4 Measure the maximum pre-test dimension of each camshaft lobe, transverse to the camshaft axis to the nearest 0.001 mm (0.00004 in.). This dimension is at the rear edge of all lobe positions (lobes are numbered from the front to the rear of the camshaft). Record the measurements on internal laboratory forms. See 10.7

10.11.5 Measure the pre-test length of the lifters at the center of the lifter foot to the nearest 0.001 mm (0.00004 in.). Record the measurements on internal laboratory forms. See 10.7

10.11.6 Record the unique serial number for each lifter on internal laboratory forms. See 10.7 Do not use electro-mechanical scribing devices. Do not place any marks on the lifter body or foot.

10.11.7 Coat the camshaft and lifters with build-up oil to prevent rusting.

10.12 Camshaft Bearing Installation-The camshaft tunnel is specially processed and uses oversize bearings provided through the CPD. Install the camshaft bearings according to the engine assembly manual guidelines. Always inspect the lifter and main bearing oil galleries for splintered babbit materials that might have been shaved from the O.D. of the bearings during installation. Remove any materials from the oil galleries with clean dry shop air. (Warning-see Note 38)

Note-38: Warning-For technical use only.

10.13 Camshaft Installation-Install the camshaft according to the following procedure:

10.13.1 Coat the camshaft with a light film of build-up oil on the journals.

Note-39 Camshafts should not sit dry inside the engine block waiting for final assembly more than 24 hours.

10.13.2 Install the camshaft in the engine block, taking care to avoid damage to the lobes, journals, and bearings.

10.13.3 Installation of Camshaft Thrust Plate-Lubricate the thrust plate with build-up oil and install the thrust plate to the front of the engine block using the torx fasteners.

10.14 Main Bearings-Verify that the main bearing bore areas in the engine block and bearing caps are clean. Install new main bearings OHT3F-042-2 in the engine block and main bearing caps, and lightly oil the bearing surfaces with build-up oil.

10.14.1 Crankshaft-Install the crankshaft.

10.14.2 Main Bearing Cap Installation-Install the main bearing caps; use a rubber or plastic mallet to seat the caps. Do not use air tools on the main bearing cap bolts to seat the caps. Install the bolts finger tight, and tighten them according to the procedure in 10.7.5.1. The main bearings should be used as received.

10.15 Crankshaft Sprocket, Install a matched set two piece crankshaft sprocket OHT3F-036-1.

10.16 Camshaft Sprocket, and Timing Chain -Install a new camshaft sprocket and chain.

10.17 Crankshaft End Play-Measure the crankshaft end play. It should be between 0.076 and 0.28 mm (0.003 and 0.011 in.).

10.18 Piston Pin Installation- Install new piston pins and retainers for each test. Clean piston pins using a clean lint free cloth and oil with EF-411. The piston pins are full floating and held in place by (2) retainers.

10.18.1 Piston Installation- Clean pistons using aliphatic naphtha and air dry prior to installation. Install the pistons according to the following procedure:

10.18.2 Piston rings are pre-gapped, see section 10.10.1, use a piston ring expander ^{xx} to install the rings on the pistons.

10.18.3 Position the ring end gaps as shown in the Sequence IIF Engine Assembly Manual section 3 sheet 8.

10.18.4 Coat the cylinder walls with build-up oil and wipe them with a clean, lint-free soft cloth, repeating the process until clean; apply a final coat of build-up oil before installing the piston assembly.

10.18.5 Coat the pistons and rings with build-up oil.

10.18.6 Install the pistons in the cylinders, using a ring compressor tool.^{xx}

10.19 Harmonic Balancer-Deburr the harmonic balancer keyway slot and the slot on the crankshaft with a mill file. The balancer

must not be installed until after the oil pump priming operation has been performed in the test stand just prior to test start.

Note-40: To make the balancer a slip fit, remove the rolled edge on the inside diameter of the balancer until the balancer slips easily over the crankshaft.

10.20 Connecting Rod Bearings- Clean the bearings using a clean lint free cloth and oil with EF-411 prior to installation. Use new connecting rod bearings OHT3F-042-2 for each test, furnished as part of the engine bearing kit.

10.20.1 Install the bearings in the connecting rods, and install the bearing caps with the rods in place on the crankshaft.

10.21 Engine Front Cover-Use a new front cover with each new engine block or if the oil pump gear rotor housing is worn.

10.21.1 Install new oil pump gears, or a new front cover and new gears, as judged necessary according to the Sequence IIIF Engine Assembly Manual inspection requirements section 4 sheet 2.

10.21.2 Ensure the oil pump relief valve moves freely inside its bore in the front cover.

10.21.3 Bolt the front cover and oil pump assembly to the engine block.

10.21.4 Inspect the oil pickup tube and screen assembly for cleanliness and install using a new gasket.

10.22 Coolant Inlet Adapter-Replace the water pump with a coolant inlet adapter as shown in drawing OHT3F-031-1.

10.23 Oil Dipstick Hole-Plug the oil dipstick hole with a hole plug (Part OHT3F-065-1). This plug is removed and the calibrated dipstick (Part OHT3F-064-1) is inserted to determine the oil level at the appropriate time during a test.

10.24 Oil Pan-Install the oil OHT3F-073-1 pan on the engine block, using a new gasket. Do not use magnetic drain plugs in the pan.

Note-41: Insure the cut out area of the windage tray / oil pan gasket does not interfere with the oil dip stick and modify if necessary.

10.25 Cylinder Head Assembly-Prepare the cylinder heads according to the following procedure:

10.25.1 Install new cup-type freeze plugs.

10.25.2 Deburr all surfaces of the cylinder heads which mate with the engine block and the manifolds with a 30-cm (12-in.) smooth file to ensure satisfactory gasket seating.

10.25.3 Thoroughly clean the cylinder heads according to section 10.6 and air (Warning-see Note-43) blow them dry prior to final assembly.

Note-42: Blank

Note-43: Warning-For technical use only.

10.25.4 Coat the valve stems and valve guides with build-up oil.

10.25.5 Install the valves and lightly lap them if desired. Clean the cylinder heads after lapping to ensure that no lapping compound remains on any parts. The valves shall be installed in the location where lapped for final assembly.

10.25.6 Install new valve stem seals over the valve stems onto the valve guides. Exercise extreme care when installing the seals in order to avoid either cutting the seals or mis-positioning them on the guides, thereby helping to preclude high oil consumption.

10.25.7 Install new valve springs OHT3F-059-5. Place the smaller diameter end of the spring against the retainer.

10.25.8 Install valve retainers and keepers.

10.26 Adjustment of Valve Spring Loads-Adjust the load of each valve spring according to the following procedure:

10.26.1 Before and after using the valve spring load measurement apparatus (such as Part BX-310-2¹⁸), calibrate the load cell using the following technique. Use dead weights to produce the specified load of 801 N (180 lbf).

Load Cell to Load Cell Technique

Affix load cell weight adapter plate (see Fig. 1) to calibration load cell. Zero the calibration load cell. Individually place calibrated dead weights onto calibration load cell. Verify that each dead weight indicates the appropriate load on calibration transducer readout. Repeat the calibration of the calibration load cell. The two consecutive readings shall agree within ± 0.5 lbs.; if not inspect the load cell and replace if necessary. Align calibration load cell beneath apparatus load cell. Place the air cylinder ram on the calibration load cell. Set the apparatus load cell to read the value of the calibration load

cell. Apply air pressure to the aligned load cells. Vary air pressure to give several different loads, including 180 lbs. Determine that both calibration and apparatus transducer readouts indicate the same value, if not, adjust the apparatus load cell. Repeat the calibration of the valve spring load measurement apparatus. The two readings shall agree within ± 0.5 lbs.; if not inspect the apparatus load cell and replace if necessary. Retain data obtained during each calibration.

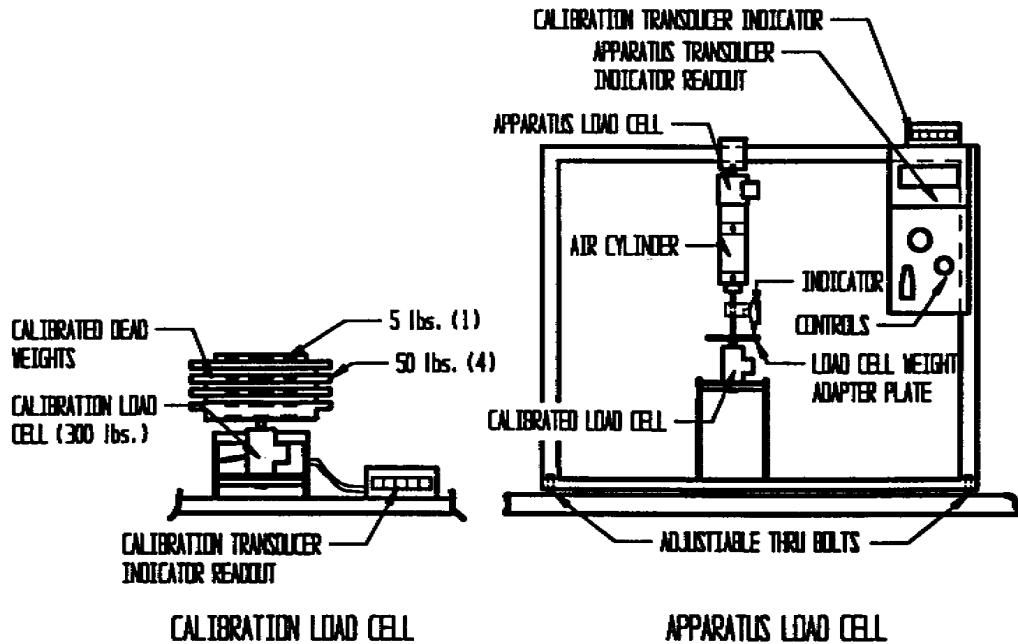

FIG. 1 Load Cell-to-Load Cell Calibration Method Diagram

10.26.2 Install a cylinder head in the holding fixture.

10.26.3 Install zeroing fixture, part D4031^{xx}, to cylinder head. Zeroing fixture, Part D4031, is part of the valve spring load measurement apparatus, Part BX-310-2.

10.26.4 Place the air cylinder loading unit over a valve and check for proper alignment of the valve tip with the loading unit.

10.26.5 Position the dial indicator and its foot on the zeroing fixture in order to accurately measure the axial movement of the valve stem.

10.26.6 Rapidly apply and release the air pressure three times to ensure free travel of the piston rod; adjust the air pressure to obtain a load cell reading of 801 N (180 lbf), if necessary.

10.26.7 If the readings are not within the specifications of 9.5 ± 0.38 mm (0.375 ± 0.015 in.) as shown by the dial indicator, and 801 N (180 lbf) load as shown by the load cell indicator, add or remove shims, or interchange parts as necessary. Repeat steps 10.26.2 through 10.26.7.

10.27 Cylinder Head Installation-New head gaskets, shall be used for each application. Do not use any sealers on the cylinder head gaskets. New fasteners shall be used for each application. Before using the fasteners for cylinder head attachment, all pre-coat sealers and thread locking compounds should be removed from the threads and underside of the bolt head using a wire wheel or brush. Do not use chemical cleaners to remove these coatings. Coat the threads and underside of the bolt head using non-hardening pliable sealing compound^{xx}. Tighten the fasteners according to the guidelines in section 5 sheet 3 of the Sequence IIIF Engine Assembly Manual.

10.28 Hydraulic Valve Lifters-Do not open the hydraulic lifter to expose any part of the internal parts. Do not remove the factory installed leak down oil. Do not electro mechanically etch identification numbers on the hydraulic lifters.

10.28.1 Prior to installation, clean the lifter body and foot using a clean cloth dampened with aliphatic naphtha (Warning-see Note-43). Do not submerge or spray the hydraulic lifter. Gently wipe the lifter body with the dampened cloth and dry using a clean dry cloth or terry towel.

Note-43: Warning-Combustible. Health Hazard.

10.28.2 Install the test lifters in the test engine, coating each lifter foot with the build-up oil before installation into the lifter bore. Rotate the engine crankshaft slowly for 720° while insuring that the lifters follow the cam lobe profile. Remove each lifter and once again coat the lifter foot with build-up oil. Reinstall the lifter into the engine block with the ground flat on the lifter body facing inboard toward the center of the engine. See the Sequence IIIF Engine Assembly Manual section 6 sheet 1.

10.29 Pushrods-Clean the pushrods with aliphatic naphtha (Warning-see Note-44), and air (Warning-see Note-45) blow them dry prior to installation; make certain that the oil passages are open. Lubricate the ball ends of the pushrods with buildup oil and install the pushrods. See the Sequence IIIF Engine Assembly Manual section 6 sheet 2.

Note-44: Warning-Combustible. Health Hazard.

Note-45: Warning-For technical use only.

10.30 Valve Train Loading-Install the rocker arm pivot retainer and the precision roller rockers and torque the rocker arm pedestal bolts according to section 6 in the Sequence IIIF Engine Assembly Manual section 6 sheet 4.

Note-46 Once the valve train is loaded, the engine shall not be rotated until the start of test using the dynamometer air starter system.

10.31 Intake Manifold-Modify the intake manifold as shown in the Sequence IIIF Engine Assembly Manual. (See section 6 sheet 7)

10.31.2 Plug the EGR port using OHT3-024-1.

10.31.3 Install OHT3F-002-1 positive crankcase ventilation valve replacement plug in the intake manifold plenum.

10.32 Rocker Covers-Install two left side rocker covers part #25534751 on the cylinder heads.

10.33 Water outlet Adapter-Install a water inlet adapter made according to drawing OHT3F-034-1.

10.34 Breather Tube-Install a breather tube mounting bracket OHT3F-041-1 and breather tube ITT 5-142-08-036-001^{xx} with an adapter OHT3F-040-1 on the front of the engine using flexible hose to connect the adapter to the rocker cover bushings OHT3F-028-1.

10.35 Coolant Outlet Adapter-Replace the thermostat housing with a coolant outlet adapter, OHT3F-034-1.

10.36 Oil Filter Adapter and Cooler-Install an oil filter adapter and cooler as shown in the Sequence IIIF Engine Assembly Manual section 8 sheet 3.

10.37 Oil Sample Valve-Install suitable plumbing to the oil pressure fitting located in the oil filter adapter to permit the removal of oil samples. Select the plumbing to minimize the added volume.

10.38 Ignition System-Install ignition system components according to the following instructions:

10.38.1 Use high-energy ignition wires which are resistant to moisture and high temperatures.^{xx}

10.38.2 Use an original equipment manufacturer coil pack mounted on the front engine mount according to drawing OHT3F026-1.

10.38.3 Use new spark plugs R42LTSM. Adjust the gaps with a wire gage to 1.14 mm (0.045 in.) Install a set of plugs prior to test start-up.

10.39 Throttle Body Modify a production throttle body according to the drawing in the Sequence IIIF Engine Assembly Manual section 7 sheet 5.

10.39.1 Install the throttle body onto the plenum and attach the throttle body adapter OHT3F-001-2.

10.40 Accessory Drive Units-Do not use any accessory drive units, such as alternators, generators, fuel pumps, power steering units, air pumps, etc.

10.41 Exhaust Manifolds, Water-Cooled-Prepare two water-cooled exhaust manifolds OHT3F-003-1 and install one on each of the two cylinder heads using transition adapters OHT3F-004-1 according to the following instructions:

10.41.1 Provide pressure taps for exhaust back pressure and exhaust gas analysis in each manifold exit plate as shown in the Sequence IIIF Engine Assembly Manual section 8 sheet 1.

10.41.2 Deburr all the surfaces of the exhaust manifolds which mate with the cylinder heads with a 30-cm (12-in.) smooth file to ensure proper gasket seating.

10.41.3 Attach the exhaust manifolds to the heads using stainless steel studs (3/8-16 x 3/8-24 x 11/2 in.), stainless steel 3/8-24 nuts, and shielded exhaust gaskets OHT3F-018-1.

Note-47: Ensure that there are no leaks between the manifold assembly components that might allow outside air to enter the exhaust system through scavenging up stream of the O₂ sensor.

10.42 Engine Flywheel-Install the flywheel and drive shaft plate assembly OHT3F-020-2

10.43 Pressure Checking of Engine Coolant System-Pressure check the engine coolant system after assembly and before installation of the engine on the test stand, according to the following procedure:

10.43.1 Block all coolant outlets, and install the necessary fittings on the coolant inlet to permit pressurizing the coolant system with air, and sealing it.

10.43.2 Pressurize the coolant system with air to 100 kPa (30 in. of Hg) (Warning-see Note-48), and seal it. Monitor the pressure for 10 min. Take no corrective action if the reduction in pressure is less than 3.4 kPa (1 in. of Hg) in 10 min. If larger changes in pressure are observed, re-torque all appropriate bolts, and replace gaskets, seals, and components (including the cylinder heads and the intake manifold) as necessary. Repeat the pressure checking.

Note-48: Warning-For technical use only.

10.44 Lifting of Assembled Engines-Lift the assembled engines with a suitable lift chain.^{xx} Do not lift the assembled engines by the intake manifold; this practice is known to generate coolant leaks.

10.45 Mounting the Engine on the Test Stand-Mount the engine on the test stand according to the following:

10.45.1 Use OHT3F-026 front and OHT3F-025 rear engine mounts.

10.45.2 Mount the engine in such a manner that the intake plenum mounting flange-to-intake manifold interface is horizontal.

10.45.3 Install an engine flywheel guard, safety housing, and air starter mounting assembly (part of OHT3F-025).

10.45.4 Connect the engine to the dynamometer with a flywheel-to-driveshaft coupling adapter (part of OHT3F-020-1) and a driveshaft.^{xx}

10.45.6 Install a coolant drain valve in the middle of each side of the block, in the 1/4-in. NPT hole. The use of street ells and petcocks has been found satisfactory. (Installation of petcocks will be assumed for the remainder of this standard.)

10.46 External Cooling System Cleaning-Clean the external cooling system of either a new or used test stand, or a new flushing tank assembly. Clean the used test stand system periodically, typically before a reference test. Use the following procedure:

10.46.1 Remove all galvanized materials from the system.

10.46.2 Prepare a cleaning mixture in the flushing tank (drawing RX-116924-C) by mixing 19.0 g/L Sequence IIIF test component cleaner (Warning-see Note 61) (see 7.4) with water. Heat the mixture to $60 \pm 2.8^{\circ}\text{C}$ ($140 \pm 5^{\circ}\text{F}$).

Note-49: Warning-Corrosive. Health Hazard.

10.46.3 Circulate the mixture at 160 L/min (42.3 gpm) flow rate for 30 min.

10.46.4 Immediately following step 10.46.3, thoroughly flush all system components with water at $60 \pm 2.8^{\circ}\text{C}$ ($140 \pm 5^{\circ}\text{F}$).

10.47 Engine Coolant Jacket (Flushing)-After the engine has been installed on the test stand, chemically clean the engine coolant jacket to ensure the proper rate of heat transfer to the jacket coolant, according to the following procedure:

10.47.1 Connect the flushing tank to the engine so that the cleaning solutions enter at the coolant outlet adapter and exit at the front of the engine block (reverse flow only for flushing) through the water inlet adapter.

10.47.2 Plug the coolant outlet hose located at the front of the engine intake manifold for this procedure.

10.47.3 For the following segments of this cleaning procedure, minimize the elapsed time between steps in order to avoid rusting of the coolant jacket.

10.47.4 Remove the oil pan drain plug. Open the engine block petcocks and pass water heated to 60 to 70°C (140 to 158°F) through the engine coolant jacket for 2 min. Check for coolant leaks around the intake manifold, front cover, rear cover, and oil pan drain plug. If coolant is leaking, take appropriate steps to stop the leak. If no leaking is evident, close the petcocks and

fill the flushing tank and engine block with water to provide a total volume of 38 to 45 L (10 to 12 gal).

10.47.5 Energize the flushing tank heaters. Circulate water through the engine at a flow rate of 115 to 130 L/min (30-35 gpm) through the engine until the temperature of the water flowing out of the engine reaches $70 \pm 3.0^{\circ}\text{C}$ ($158 \pm 5.0^{\circ}\text{F}$).

10.47.6 While the water continues to circulate through the engine, add 19 g/L Sequence IIIF test component cleaner (Warning-see Note-50) (see 7.4) to the water in the flushing tank.

Note-50: Warning-Corrosive. Health Hazard.

10.47.7 Continue to circulate the mixture through the engine for 30 min.

10.47.8 Stop the circulation pump and skim any oily surface film from the flushing tank using a suitable blotter-type material. Open the engine block petcocks, and drain the contents of the engine and flushing tank into a suitable container.

Note-51: The drained material should be neutralized before disposal according to applicable local and federal hazardous material guidelines.

10.47.9 Close the engine block petcocks and flow hot tap water through the engine into a suitable container, for 2 to 5 min, until the pH of the water flowing out of the engine is neutral. Use water at a temperature of 60 to 70°C (140 to 158°F). Maintain a flow rate of 76 to 95 L/min (20 to 25 gal/min). (See Note-51)

10.47.10 Immediately after neutralizing the engine block in 10.47.9, open the block petcocks and after draining all flush water remove the four freeze plugs from the sides of the engine block. Using a flashlight, inspect the block for any remaining core sand or slag by looking up through the freeze plug holes toward the cylinder head attachment bolts which protrude downward through the cylinder block deck. If deposits are present, use compressed air (Warning-see Note-52) and high-pressure water, together with a sharp object such as a thin-blade screwdriver, to dislodge and remove the deposits. Also, check for deposits on the jacket walls surrounding the cylinders by wiping the walls with a finger. Replace the freeze plugs, and circulate tap water through the engine for 10 min. Repeat the freeze-plug-removal, inspection, and cleaning procedure until all deposits are removed. After all deposits are removed, repeat chemical flushing procedure.

Note-52: Warning-For technical use only.

Note-53:-Speed is essential to prevent the water jacket from air drying and oxidizing.

10.47.11 Quickly install new cup-type freeze plugs.

10.47.12 Connect the engine to the external engine cooling system.

10.47.13 Immediately charge the engine jacket with coolant.

10.48 Coolant Charging-Charge the engine jacket with the specified inhibited glycol coolant (Warning-see Note-54), according to the following procedure:

Note-54: Warning-Combustible. Health Hazard.

10.48.1 To preclude contamination of the coolant system with water, install low-point drains and eliminate all traps in the system. Drain all water in the system.

10.48.2 Use a charging adapter installed between the external cooling system and the engine.

10.48.3 Completely fill the engine jacket and cooling system with inhibited coolant (see 7.3). (Warning-see Note-55) Fill the engine coolant jacket before filling the breather tube system.

Note-55: Warning-Combustible. Health Hazard.

10.48.4 Charge the breather tube coolant system immediately after charging the engine cooling system.

10.48.5 Cycle the circulating pump on 15 seconds and off 45 seconds for a 5-min. period to aid in the removal of air and consequently decrease the time to achieve clarity of the coolant. During this period, operate any proportioning valves in the coolant system several times.

10.48.6 Until the test is started, circulate the coolant at a temperature of $48.9 \pm 2.8^{\circ}\text{C}$ ($120 \pm 5^{\circ}\text{F}$) and a flow rate of 160 L/min (40 gpm). Start the test no later than 6 hours after step 10.48.5

10.49 Test Oil Charging-Charge the engine with the test oil as follows:

10.49.1 Install the engine oil filter adapter OHT3F-035-1.

10.49.2 Install a new oil cooler OHT3F-030-1.

10.49.3 Install a new oil filter OHT3F-057-1.

10.49.4 Connect the external oil cooler lines to the oil cooler.

10.49.5 Add an initial fill of 5.50 L (5 qt, 26 oz) of fresh test oil through the rocker cover oil fill cap.

10.50 Engine Oil Pump Priming-Prime the engine oil pump according to the following instructions:

10.50.1 With the front balancer and front half of the oil pump drive gear OHT3F-036-1 removed, use a suitable high torque drill motor and oil pump drive tool OHT3F-038-1 rotating the gearotor oil pump in a clockwise direction for two minutes after indication of oil pressure.

10.50.2 Replace the front half of the oil pump drive gear and the front balancer and torque the balancer to 150 N.m+ 76° (111 lb.ft. + 76°).

10.50.3 Connect the crankcase pressure line and oil sample valve fittings in preparation for testing, and proceed with the initial run operation.

11. Calibration

11.1 Laboratory and Engine Test Stand Calibration-To maintain testing laboratory and engine test stand calibration status for Sequence IIIF engine oil testing, follow these directions:

Note-56 Annexes A1 and A5 cover the involvement of the ASTM TMC in respect to calibration procedures and acceptance criteria for a testing laboratory and a test stand, and the issuance of Information Letters and memoranda affecting the test method.

11.2 Testing of Reference Oils-Periodically conduct tests on reference oils according to the following:

11.2.1 Reference oil tests conducted on each test stand within a laboratory which is to be considered calibrated must be conducted according to ASTM Test Monitoring Center guidelines.

11.2.2 Obtain reference oils directly from the ASTM TMC. These oils have been formulated or selected to represent specific chemical types or performance levels, or both. They are usually supplied directly to a testing laboratory under code numbers to ensure that the laboratory is not influenced by prior knowledge of acceptable results in assessing the test results. The ASTM TMC will determine the specific reference oil to be tested by a laboratory.

11.2.3 Unless specifically authorized by the ASTM TMC, do not analyze reference oils, either physically or chemically. Identification of reference oils by such analyses could undermine the confidentiality required to operate an effective reference oil system. Therefore, reference oils are supplied with the explicit understanding that they will not be subjected to analyses other than those specified in this procedure, unless specifically authorized by the ASTM TMC. If so authorized, prepare a written statement of the circumstances involved, the name of the person authorizing the analysis, and the data obtained; furnish copies of this statement to both the ASTM TMC and the Test Developer.

11.2.4 Assign a stand test number to each Sequence IIIF test. The number must include the test type (IIIF), the stand number, the number of Sequence IIIF tests conducted on the stand since the last reference oil test was conducted (0 to 15), and a sequential laboratory test number based on the starting date of the test. For example, IIIF-60-03-785 defines a Sequence IIIF test on stand number 60, which is the third non-reference oil test run on stand 60 since successful completion of a reference oil test, and was the 785th Sequence IIIF test in the laboratory. The only exception to this format is that the sequential laboratory test number shall be followed by the letter A for the first rerun, B for the second, etc. for invalid or unacceptable reference oil tests.

11.3 Reference Oil Test Frequency-Conduct reference oil tests according to the following frequency requirements:

11.3.1 For a given calibrated test stand, conduct an acceptable reference oil test after no more than 15 test starts have been conducted, or after 120 days have elapsed, whichever occurs first.

11.3.2 For a given testing laboratory with more than one calibrated test stand, conduct an acceptable reference oil test after no more than 90 days have elapsed since the last reference oil test.

11.3.3 After a laboratory reference oil test is started, non-reference oil tests may be started on any other calibrated test stands.

11.3.4 The ASTM TMC may schedule more frequent reference oil tests at their discretion.

11.3.5 Under special circumstances, such as extended downtime caused by industry-wide parts or fuel shortages, the ASTM TMC may extend the intervals between reference oil tests.

11.3.6 In addition to the aforementioned reference oil tests, the ASTM TMC will schedule periodic runs at each laboratory on a poor-quality reference engine oil for each test stand within that laboratory in order to ensure that each laboratory can produce adequate discrimination. In general, the ASTM TMC will not use the results of such tests in determining laboratory precision, but the ASTM TMC is authorized to so use the results if they choose.

11.4 Reporting of Reference Oil Test Results-Report the results of all reference oil tests to the ASTM TMC according to the following directives:

11.4.1 Results are to be transmitted to the TMC within 5 days of test completion via electronic data transfer protocol as outlined in the Data Communication Committee Electronic Test Report Transmission Model (ETRTM). The ETRTM can be obtained from the TMC.

11.4.2 If the test was conducted during a time extension permitted by the ASTM TMC, so indicate in the Comments section of the test report.

11.4.3 For an acceptable reference oil test, conducted following an unacceptable reference oil test. Provide sufficient information in the Comments section of the test report to indicate how the problem was identified and corrected, insofar as possible, and how it was related to candidate oil tests conducted during the period of time that the problem was being solved.

11.4.4 Send by mail one copy of the standard final report (Use the report forms supplied by the ASTM TMC. Report forms can be obtained from the TMC web site: <ftp://tmc.astm.cmri.cmu.edu/datadict/> or by contacting the TMC.) to the Test Developer, and one copy of the report to the ASTM TMC, at the following addresses in order that the records are received within 30 days of test completion.

General Motors Corporation
Research and Development Center
Mail Code 480-106-160
Sequence IIIF Test Coordinator
30500 Mound Road
Box 9055
Warren, MI 48090-9055

Test Report Clerk
ASTM Test Monitoring Center
6555 Penn Avenue
Pittsburgh, PA 15206

11.5 Evaluation of Reference Oil Test Results-The ASTM TMC will evaluate the reference oil test results for both operational validity and statistical acceptability. The TMC may consult with the Test Developer, and test laboratory in case of difficulty, as follows:

11.5.1 Immediately upon receipt of the reference oil test results from the test laboratory, the ASTM TMC will evaluate the laboratories decision on operational validity. For operationally valid tests the TMC will then evaluate the pass/fail parameters according to the Sequence IIIF Lubricant Test Monitoring System (ASTM TMC Memorandum 94-200). If the test is judged acceptable, the reference oil code will be disclosed by the ASTM TMC to the test laboratory. The ASTM TMC will convey its preliminary findings based on the limited information available to them, to the test laboratory.

11.5.2 Subsequently, upon receipt of the information detailed in 11.4.4, the ASTM TMC will review all reference oil test results and reports to determine final test acceptability.

11.5.3 In the event the reference oil test is unacceptable, an explanation of the problem relating to the failure should be provided by the test laboratory. If the problem is not obvious, all test-related equipment must be re-checked. Following this re-check, the ASTM TMC will assign another reference oil for testing by the laboratory.

11.5.4 The ASTM TMC will decide, with consultation as needed with industry experts (testing laboratories, Test Developer, members of the ASTM Technical Guidance Committee and of the Surveillance Panel, etc.), whether the reason for any failure of a reference oil test is a false alarm, testing stand, testing laboratory, or industry-related problem. Industry problems must be adjudicated by the Sequence IIIF Surveillance Panel.

11.6 Status of Non-Reference Oil Tests Relative to Reference Oil Tests-Non-reference oil tests may proceed within a given laboratory during reference oil testing based upon the following:

11.6.1 During the time that a reference oil test is being conducted on one test stand, non-reference oil tests may be conducted on other previously-calibrated stands. If the reference oil test is acceptable to the ASTM TMC, the non-reference oil tests will be considered to have been run in a satisfactorily-calibrated laboratory.

11.6.2 If a reference oil test is unacceptable, and it is determined that the problem is isolated to an individual test stand, other test stands will be considered to remain calibrated,

and testing of non-reference oils may proceed on those other stands.

11.6.3 If a reference oil test is unacceptable, and it is determined that the problem is laboratory related, non-reference tests running during the problem period must be considered invalid unless there is specific evidence to the contrary for each test.

11.7 Status of Test Stands Used for Non-Standard Tests-If a non-standard test is conducted on a previously-calibrated test stand, conduct a reference oil test on that stand to demonstrate that it continues to be calibrated, prior to running standard tests.

11.8 Data Acquisition and Control-The Sequence IIIF test requires the use of computerized data acquisition and control for all measured and controlled parameters outlined in this procedure. The system chosen by individual testing laboratories must be capable of integrating with the Sequence IIIF Process Controller for many of these operations. The system must also be capable of meeting or exceeding certain test specific performance requirements for maximum allowable response times and minimum allowable sample rates. In addition to the aforementioned requirements, the system must also be capable of data logging to test specific archival files for each test parameter at minimum allowable record intervals, i.e., no greater than two-minute intervals between successive logs for each parameter. See the Data Acquisition and Control Automation II Task Force Report ^{xx} and additional requirements as outlined in this procedure.

11.8.1 Sample Rate-The preferred sample rate is 100Hz with the minimum allowable sample rate for the Sequence IIIF data acquisition and control system set at 1Hz.

11.8.2 Measurement Accuracy- All measurement devices used for sensing speed, load, flow, pressure, and temperature must meet the minimum requirements as outlined in the DACA II report and also conform to total system response requirements as outlined by the TMC. The following is a list of minimum requirements for Sequence IIIF testing:

11.8.3 Temperature-Use only iron-constantan (type J) thermocouples with an accuracy of $\pm 0.5^{\circ}\text{C}$ over a range of 0-200 $^{\circ}\text{C}$.

11.8.4 Pressures-For pressures > 6.9 kPa, use only measuring devices with an accuracy of $\pm 0.2\%$ of full scale for capacitive systems and $\pm 0.25\%$ of full scale for strain type systems. For pressures < 6.9 kPa, use only devices with an accuracy of ± 15 Pa for capacitive and ± 14 Pa for strain type systems.

11.8.5 Flow-For systems incorporating vortex shedding measuring (liquid) use $\pm 0.75\%$ of reading, vortex shedding measuring (gas) use $\pm 3.0\%$ of full scale. For magnetic measurement use $\pm 1.0\%$ of reading and coriolis measurements use $\pm 0.25\%$ of reading.

11.8.6 Speed-For speed measured by frequency use ± 1 rpm.

11.8.7 Load-For load measured by strain gage use $\pm 0.25\%$ of full scale.

11.8.8 Measurement Resolution-Resolution for all parameters should be at least 4 times greater than the required system accuracy for that parameter i.e., test procedure accuracy = 1.0 units then the minimum resolution of that parameter = 0.25 units.

11.8.9 System Time Response -Total system time response is the time required for the complete data acquisition system including all filtering, transducer lines, and surge tanks to measure a step change input for a given parameter. System response times should be determined by measuring the time required to reach a certain percentage of an imposed step change. For first order systems use the time to 63.2% of the imposed step change and for moving average systems use the time to 45.4% of the imposed step change.

See the TMC System Time Response Measurement Guidelines for methods of imposing step changes for calibration of Sequence IIIF test stands.

See Annex A9 for maximum allowable system time responses for the data acquisition system.

11.8.10 Quality Index-Use of the quality index method of measuring the control capability of the test stand is required for certain parameters. The following formula should be used and a minimum of 2400 data records are required for the final end of test values.

$$QI = 1 - \frac{1}{n} \sum \left(\frac{U + L - 2X_i}{U - L} \right)^2$$

X_i = Recorded test measurement parameter

U = Upper specification for that parameter

L = Lower specification for that parameter

n = Total number of data points taken as determined from test length and procedural specified sampling rate

The upper and lower values used for QI calculations for the required parameters are listed in Annex A8.

12. Engine Operating Procedure

12.1 Dipstick and Hole Plug-Remove the calibrated dipstick and close off the dipstick hole in the block with the required plug, for all engine operation. See the Sequence IIIF Engine Assembly Manual.

12.3 Engine Start-up and Shutdown Procedures-Start and stop Sequence IIIF engines according to the following procedures and the test states and setpoints listed in Annex A8 Fig.1.1, 1.2 and 2.

12.4 Start-up-Use the following procedure in starting Sequence IIIF engines:

12.4.1 Supply power to the Powertrain Control Module, fuel pump, and all AFR control units for a minimum of 30 seconds before cranking engine to assure all systems are prepared for closed loop AFR control.

12.4.2 At the same time start the coolant flowing through the exhaust manifolds.

12.4.3 If the engine fails to start after 5 seconds, the problem must be found and corrective action taken before any further attempts are made. A log entry of any failed attempt and any corrective action must be made in the test report.

12.4.4 When the engine has been started, verify that oil pressure is adequate, and the speed is set to 1500 r/min and the load to 6.34 kW (8.5 bhp).

12.5 Scheduled Shutdown-Use the following procedure in stopping Sequence IIIF engines:

12.5.1 Reduce the engine speed and load to 1500 r/min and 6.34 kW (8.5 bhp) with a linear ramp down over 30 s (if applicable). Within 90 s, remove the required oil purge sample and analysis sample from the engine oil sampling valve and adjust all temperatures for engine shutdown.

12.5.1.1 Prior to shutdown on the initial run and at the end of test, add the 472 ml (16 oz) purge back to the engine.

12.5.1.2 Prior to shutdown on all oil levels except the initial and the end of test, add the new oil, 472 ml (16 oz) plus an additional 59 ml (2 oz) of new oil to the engine prior to shutdown.

12.5.2 Turn off ignition power to the PCM.

12.5.3 With the engine stopped, stop the coolant flow through the exhaust manifolds and continue with the oil sampling and leveling procedure (see 12.7 through 12.8).

12.6 Non-Scheduled Shutdowns-For any non-scheduled shutdowns, record in detail the time off test, the reasons for the shutdown, and any other pertinent observations. Include this record in the test note section of the final test report.

12.7 Oil Sampling- With the engine running at 1500 r/min, remove all oil samples from the engine oil sampling valve according to the following instructions:

12.7.1 Before taking the samples in each of the following steps, first remove a 472-mL (16-oz) purge sample, or leveling sample; then remove the oil sample of the specified volume.

12.7.2 Take a 236-mL (8-oz) analysis sample at the end of the initial run (identified as the initial sample) and at the end of the 80-h test.

12.7.3 Take a 59-mL (2-oz) sample at the end of every 10-hours during the test, except at the end of the 80th hour when a 236-mL (8-oz) end of test sample is taken.

12.8 Oil Leveling-Determine the oil level in the crankcase according to the following instructions:

12.8.1 Determine the oil level after the 10-min initial run and after each 10-h of test.

12.8.2 Stop the engine according to the procedure in 12.5 for 15 min to allow the oil to return to the crankcase.

12.8.5 During the 20-min period, maintain the breather tube temperature at 40°C (104°F) and the coolant jacket temperature at 49°C (120°F).

12.8.6 Determine the oil level after the 15-min period, in mm, using the calibrated dipstick.

12.8.7 Following the initial run, record the oil level on Annex A10, according to 12.8.6. Use this level as the full mark for the test. Enter 0 (zero) mL as the computed oil level on Annex A10.

12.8.8 After each 10-h of the 80-h test, except at the end of test, add oil to the crankcase from the 472-mL purge sample to bring the level to that following the initial run, as nearly as

possible. Discard any excess purge sample. Record the results on Fig. XX.

12.9 Checks for Glycol Contamination-Check the initial, 40-h, and end-of-80-h-test oil analysis samples (see Fig. X4.4) for glycol contamination using A.1.2.1 of Test Methods D 2982, according to the following procedure:

12.10 Air-to-Fuel-Ratio Measurement and Control-Measure and control air-to-fuel ratio according to Annex A7.

12.11 Blowby Flow Rate Measurement-Measure the engine blowby flow rate according to the following instructions, and within 15 min. of the end of each period indicated on Form 10, Blowby Values & Plot, in standardized report form set (See Annex A6).

12.11.1 Observe the following requirements:

12.11.2 Measure the blowby flow rate at the breather tube outlet.

12.11.3 Verify that the dipstick hole is sealed during engine operation with the dipstick hole plugged.

12.11.7 Direct the blowby gas into a suitable vent hood at all times. Do not allow the vent system to create a negative draw on the crankcase.

12.11.8 Connect a surge tank, drawing RX-117431-C, to the breather tube.

12.11.9 Connect the blowby flow rate meter to the surge tank.

12.11.10 When permanently installed blowby meters are not used, portable cart applications are allowed. However, position the cart near the testing area for a sufficient time period to assure temperature stabilization of the system components prior to any blowby measurements being taken. Temperature stabilization is necessary to reduce condensation precipitation of the blowby gases. The moisture content of blowby gases are generally between 17 and 20 g/g (120 to 140 grains per lb.). Correction factors are based on this and other average Orsat data of the blowby gases. Therefore, it is important that the blowby gases being measured at the orifice plate be as close in molecular composition and temperature as possible to the blowby gases exiting the breather tube.

12.11.11 The exhaust line for the engine blowby gas being measured shall not be evacuated nor directed toward any low pressure evacuation systems.

12.11.12 Select an orifice size such that the observed blowby flow ΔP lies in the midrange of the calibration curve. Record the orifice size used.

12.11.13 Control the crankcase pressure at 0 ± 12.4 Pa (0.0 ± 0.05 in. of water).

12.11.14 Maintain blowby gas flow through the orifice meter for 2 min. or more to ensure flow stability, prior to taking the actual readings. Due to the relatively low flow rates, allow time for the engine blowby gas to fill the system and further enhance temperature stabilization.

12.11.15 Record the uncorrected blowby flow rate in L/min and correct it for an atmospheric pressure of 100 kPa (29.70 in. Hg) and a temperature of 37.8°C (100°F), using the correction factors given in Table xx and Table xx. NEED DATA

12.11.16 Alternatively, correct the blowby flow rate using the following equations, on which table xx and table xx are based:

$$CF_{Si} = \left(3.1002 \left(\frac{P_{kpa}}{273.15 + t \circ C} \right) \right) 0.5$$

$$CF_{in-lb} = \left(18.844 \left(\frac{P_{in.Hg}}{459.67 + t \circ F} \right) \right) 0.5$$

12.11.17 Disconnect the surge tank from the breather tube.

12.11.18 Direct the blowby gas into the vent hood, drawing RX-118623-A2, at all times other than when the blowby flow rate is being measured.

12.12 NO_x Determinations-Measure NO_x concentrations using suitable exhaust gas analysis equipment at 7 h, 39 h, and 79 h. record the data on Fig. XX.

12.13 Data Recording-Record data at a minimum of every two minutes for all parameters listed in Annex A8 Fig. 2.

12.14 Initial run (10 min)-After the engine is charged with the test oil and primed, conduct the 10-min initial run.

12.14.2 Start the engine (see 12.4). Begin timing the 10-min initial run.

12.14.3 Maintain the ignition voltage at 13 Volts minimum.

12.14.4 Make certain that coolant is flowing through the water-cooled exhaust manifolds.

12.14.5 Control the coolant jacket and oil sump temperatures at $50.0 \pm 2.0^{\circ}\text{C}$ ($122 \pm 3.6^{\circ}\text{F}$), and the breather tube coolant temperature at $40.0 \pm 2.0^{\circ}\text{C}$ ($104 \pm 3.6^{\circ}\text{F}$) during the initial run.

12.14.6 Set the engine speed at 1500 r/min, no load; operate for 2 min to check for leaks.

12.14.7 Operate the engine at 1500 r/min, 6.34 kW (8.5 bhp) for the remainder of the 10 min.

12.14.8 Ten minutes after the initial run start, and just prior to stopping the engine, remove a 472-mL (16-oz) purge sample, then take the initial, 236-mL (8-oz), 0-h oil sample.

12.14.9 Stop the engine (see 12.5).

12.14.10 Follow 12.7 and 12.8 to determine the oil level after drain-down, mm; record the value on Annex A10. Use this level as the full mark for the test.

12.15 Engine Oil Quality Testing (80-h)-After completing all phases of the initial run, conduct the 80-h engine oil quality evaluation portion of the test, according to the following procedure:

12.15.1 Start the engine (see 12.4).

12.15.2 Ensure the throttle body humidified air inlet supply to the engine is connected.

12.15.3 Maintain the ignition voltage at 13 Volts, minimum.

12.15.4 Operate the engine under the test conditions listed in Annex A8. Fig. 1.1, 1.2, and Fig.2.

12.15.5 For each 10-h segment of the 80-h engine oil quality testing, test time is counted from the moment when all the test conditions listed in Annex A8 are reached and stabilized. Start calculating QI values when temperatures are stable or when test state warm up times are exceeded. If engine is shut down for any

reason except oil leveling, start counting down time. Maximum allowable down time for the IIIF test is 24 hours.

12.15.6 Every 10-h, conduct the oil sampling and oil leveling according to 12.5 and 12.6. See Annex A10. Record the time when the final (80-h) leveling is completed; be aware that most of the engine disassembly must be completed within 4 h of this time. See 13.1.1.

12.16 Test Termination-Terminate the test as follows:

12.16.3 Terminate the test at the completion of the 80-h engine oil quality testing, following the taking of the purge and analysis samples and completion of the end of test oil leveling procedure. Record the end of test time after the final engine oil level procedure.

12.16.3.1 Drain the oil sump.

12.16.3.2 Drain the breather tube cooling system.

12.16.3.3 Drain the engine coolant.

12.16.3.4 Immediately flush the glycol side of the external engine cooling system with water at a temperature of 49°C (120°F) until the flush water is clear.

12.16.3.5 Remove the engine from the test stand, and transport it to the engine disassembly area for determination of test results.

13. Determination of Test Results-

13.1 This section describes techniques used to evaluate the oils performance with respect to oxidation (viscosity increase), wear (camshaft and lifter), piston deposits, ring sticking, sludge deposits, oil pump screen plugging , and oil consumption.

13.2 Engine Disassembly-Disassemble the engine according to the following instructions, in preparation for inspection, rating, and measurement:

13.2.1 Plan the disassembly so that the parts to be rated for sticking, deposits, and plugging (pistons, rings, and oil screen) shall be removed from the engine within 12 hours of the completion of the oil level.

13.2.2 Remove the components from the top of the engine in order to gain access to the cylinder bores.

13.2.3 Remove the carbon deposits from the top portion of the cylinder walls, above the top compression ring travel, before removing the pistons from the engine.

13.2.4 Disassemble the remainder of the engine.

13.3 Preparation of Parts for Rating of Sticking, Deposits, and Plugging-Prepare the specified parts for rating according to the following instructions:

13.3.1 Check all piston rings for freedom of action in the grooves as the pistons are removed from the engine. See 13.5.1 through 13.5.1.3.

13.3.2 Remove all piston rings that are free. Leave stuck rings (includes pinched or pivot condition) in place. Stuck rings will be rated as having 100% heavy carbon in the groove.

13.3.3 If the piston deposits cannot be rated immediately after the pistons are removed from the engine, store the pistons in a vacuum desiccator for no longer than 72 h from end of test before rating. Do not wipe the pistons before storing them. See 13.7.

13.4 Piston deposit ratings - The pistons are rated for skirt varnish, oil ring land deposits, and overall piston deposits using the (Weighted Piston Deposit - WPR)

13.4.1 Establish the proper environment for parts rating (see section xxx). Rate all parts against a white background.

13.4.2 Rate piston skirt deposits use CRC manual 14 rating scale and breakdown method under a lamp with two 15-watt cool-white fluorescent tubes which together produce 350 to 500 fc (3800 to 5400 lx) at the rating surface. These ratings will be used for IIIF deposit determinations.

13.4.3 Blank

13.4.3.1 Rate the oil pump screen for percent plugging (using CRC manual 12).

13.4.3.2 In addition to the ratings generated in section 13.4.2, rate each piston top groove, 2nd groove, oil ring groove, 2nd land, and undercrown (Band-Aid area) for deposits using CRC manual 14 rating techniques and breakdown method. Carbon deposit ratings will consist of only two levels: Heavy = 0.00 merit value or Light = 0.75 merit value. These ratings should be performed in a rating booth, using a 20-segment piston rating cap, a piston rating stand, and a 22watt circular rating lamp.

13.4.4 If multiple ratings are deemed necessary of a given part or parts, consensus rating may be used according to the following:

13.4.4.1 The raters shall be from the laboratory in question, no outside raters can be used unless requested and directed through the Sequence IIIF Surveillance Panel.

13.4.4.2 No averaging of ratings is permitted.

13.4.4.3 Only one rating value is to be reported and is to be agreed to by the raters involved.

13.5 Piston Ring Sticking-Rate the piston rings for hot-stuck and cold-stuck rings as follows:

13.5.1.1 See Section 3 for the definition of hot-stuck and cold-stuck rings.

13.5.1.2 Determine which rings are hot-stuck or cold-stuck and record the piston number and ring identification (for example, piston No. 3, top ring) for such rings on Form 8, Summary of Oil Ring Land Deposit Rating, in standardized report form set (See Annex A6). Record the total number of hot-stuck rings on Form 4, Test Result Summary, in the standardized report form set (See Annex A6).

13.6 Intentionally left blank

13.7 Piston Skirt Deposits Rating-Rate the piston skirts for deposits using CRC manual 14 rating scale and breakdown method to a tenth of a number. Average the results and report them to the nearest hundredth of a number. Proceed according to the following instructions:

13.7.1 Rate the piston skirt deposits immediately upon removal of the pistons from the engine, or within 2-hours after removal of pistons stored in a desiccator. See 13.3.3.

13.7.3 Gently wipe off any excess oil from the piston skirts with a soft cloth.

13.7.4 Do not apply any chemicals or build-up oil to the skirts prior to rating them for deposits.

13.7.7 Average each individual piston (thrust side and anti-thrust side) for inclusion in Weighted Deposit Rating (WDR).

13.7.9 Record ratings on Form 9, Summary of Piston Deposits, in standardized report form set (See Annex A6).

13.7.10 Calculate the average thrust and anti-thrust values and record on Form 9, Summary of Piston Deposits, and on Form 4, Test Results Summary, in standardized report form set (See Annex A6). Calculate the average of the values of the twelve skirts, and record it as the official piston skirt varnish average on Form 9, Summary of Piston Deposits, and on Form 4, Test Results Summary, in standardized report form set (See Annex A6). Report average results to two places after the decimal point (for example, 8.65).

13.7.11 Report any unusual piston skirt deposits observed in the comments section of Form 9, Summary of Piston Deposits, in standardized report form set (See Annex A6)

13.7.12 Upon completion of the rating and photographing of the pistons, apply build-up oil to the pistons to help preserve their condition during storage.

13.8 Oil Ring Land Deposits Rating-Rate the piston oil ring land (the face of the land above the oil ring) deposits to the nearest hundredth of a number. Use CRC manual 14 and breakdown method. Refer to Practice E 29 for any needed rounding; use the rounding-off method. Proceed according to the following instructions:

13.8.1 Rate the piston oil ring land deposits immediately upon removal of the pistons from the engine, or within 2-hours after removal of pistons stored in a desiccator. See 13.3.3.

13.8.3 Gently wipe off any excess oil from the piston oil ring lands with a soft cloth.

13.8.4 Do not apply any chemicals or build-up oil to the oil ring lands.

13.8.5 Use the rating procedures contained in CRC Manual 14 (non-rubbing scale).

13.8.6 Rate only the deposits present. Though chipped areas might sometimes appear, rate what appears and do not interpolate deposits.

13.8.8 Record the rating results on Form 8, Summary of Oil Ring Land Deposit Rating, in standardized report form set (See Annex A6)

13.8.9 Calculate the average of the six ratings; record this as the official ring land deposit average on Form 8, Summary of Oil Ring Land Deposit Rating, and on Form 4, Test Results Summary, in standardized report form set (See Annex A6).

13.9 Weighted Piston Deposit Rating (WPD) - This weighted piston rating is comprised of skirt varnish (section 13.7), oil ring land deposit (section 13.8), top groove, 2nd groove, oil ring groove, undercrown, and 2nd land.

13.9.1 Prepare pistons for rating - Gently wipe excess oil from the grooves and lands using a soft cloth.

13.9.2 Rate each piston top groove, 2nd groove, oil ring groove, 2nd land, and undercrown (Band-Aid area) using CRC manual 14 rating techniques and breakdown method. Carbon deposit ratings will consist of only two levels: Heavy = 0.00 merit value or Light = 0.75 merit value. These ratings should be performed in a rating booth, using a 20-segment piston rating cap, a piston rating stand, and a 22watt circular rating lamp.

13.9.3 The Weighted Deposit Rating (WDR) for each individual piston is calculated using the following factors:

Piston Undercrown	10%
2 nd Land	15%
3 rd Land (ORLD)	30%
Piston Skirts (avg)	10%
Top Groove	5%
2 nd Groove	10%
Oil Ring Groove	20%

13.9.4 The Weighted Deposit Rating (WDR) for the test is calculated by a simple average of the six individual piston WDR ratings. Report this value Form 9, Summary of Piston Deposits, in standardized report form set (See Annex A6).

13.10 Oil Ring Plugging Observations-Rate the specified parts for plugging to the nearest whole percentage number. Refer to Practice E 29 for any needed rounding; use the rounding-off method. Proceed according to the following instructions:

13.10.1 Rate the oil rings for percent plugging of the rail separators. Record the results on Fig. A6.8.

13.10.2 Calculate the average percent plugging. Record the answer on Form 8, Summary of Oil Ring Land Deposit Rating, in standardized report form set (See Annex A6).

13.11 Post-Test Camshaft and Lifter Wear Measurements-Measure the wear of the camshaft lobes and lifters to the nearest 0.001 mm (0.00004 in.) Refer to Practice E 29 for any needed rounding; use the rounding-off method. Proceed according to the following procedure:

13.11.1 Clean the camshaft lobes and lifters with aliphatic naphtha (Warning-see Note 76); blow dry them with clean, dry shop air. (Warning-see Note 77.)

Note 76: Warning-Combustible. Health Hazard.

Note 77: Warning-For technical use only.

13.11.2 Store the camshaft and lifters in a temperature-controlled room for at least 90 min before making dimensional measurements, to ensure temperature stabilization. The temperature of the post-test measurement room must be within 3°C (5°F) of the temperature of the pre-test measurement room.

13.11.3 Use dimensional measuring equipment accurate to 0.001mm. Before each measurement session, use standards traceable to the National Institute of Standards and Technology, to ensure measuring equipment accuracy. Include standards having length values within 1.3 mm (0.05 in.) of the typical lifter and lobe measurements taken. Use the same equipment and standards for post-test measuring as were used for pre-test measuring. If a calibration shift between pre-test and post-test measurements is detected, evaluate the shift to determine its effect on the wear measurements. Record the results of the evaluation, and any corrective action taken.

13.11.4 Measurements on a camshaft and the lifters used in a given test must be made by the same person if the measurement equipment utilized is operator-sensitive (that is, if a micrometer is used with which the operator determines the spindle pressure).

13.11.5 When measuring the camshaft and the lifters, take precautions to prevent any influence of body heat on the measurements.

13.11.6 Measure the maximum dimension of each camshaft lobe, transverse to the camshaft axis. This dimension is at the rear edge of all lobes (lobes are numbered from the front to the rear of the camshaft).

13.11.7 Measure the length of the lifters at the center of the lifter foot.

13.11.8 Calculate the wear for each camshaft lobe and lifter by subtracting the after-test measurement from the before-test measurement.

13.11.8.1 Due to varnish accumulations on camshaft lobes of high wear resistant oils, post-test measurements may indicate a larger numeric value than pre-test measurements. In this situation, the end of test calculation equates to a negative value. All negative values shall be overridden and entered as "0.000 mm" wear for all calculations when determining post-test results.

13.11.9 Calculate the cam-plus-lifter wear by adding the values obtained in 13.11.8. Record the results on Form 7, Valve Lifter and Camshaft Wear Results, in standardized report form set (See Annex A6).

13.11.10 Determine the maximum, minimum, and average camshaft-lobe, valve-lifter, and cam-plus-lifter wear. Record the values on Form 7, Valve Lifter and Camshaft Wear Results, in standardized report form set (See A6).

13.12 Used Oil Sample Testing - With the following exceptions, conduct a Cold-Cranking Simulator test (Test Method D5293) and a Mini Rotary Viscometer test (Test Method D4684) on the end-of-test used oil sample. Report the results on Form 8, Used Oil Analysis Results, in the standardized report form set (See A6).

13.13.1 If the viscosity increase for the test is higher than 500% (See 13.13), the Cold-Cranking Simulator and Mini Rotary Viscometer tests are not required.

13.13.2 If the test oil is a straight-grade oil, the Cold-Cranking Simulator and Mini Rotary Viscometer tests are not required.

13.13.3 If the end-of-test used oil sample fails the Cold-Cranking Simulator test at -5°C , the Mini Rotary Viscometer test is not required.

13.13 Viscosity Test-Determine the viscosity of a sample of the fresh test oil and of the nine test samples by analysis according to the following instructions:

13.13.1 Do not filter the samples.

13.13.2 Use Test Method D 445.

13.13.3 Use either the Cannon-Fenske Routine Viscometer of the Ostwald Type for Transparent Liquids, or the Cannon-Fenske Opaque Viscometer of the Reverse-Flow Type for Transparent and Opaque Liquids.

13.13.4 Conduct the measurement at 40°C (104°F).

13.13.5 Record the results on Fig. A6.4

13.13.6 Critically examine the relationship of the viscosity of the initial oil sample to that of the new oil. The viscosity of the initial sample can legitimately be as much as 10 cSt less than that of the new oil, because of permanent shearing effects. If the difference is greater than 10 cSt, explore possible causes such as failure to purge the oil sample line [removing the 473-mL (16-oz) purge sample] prior to withdrawing the 237-mL (8-oz) analysis sample, or an excessive amount of build-up oil in the system.

13.13.7 Calculate the change in viscosity in centistokes, from the value for the initial sample, for the last eight samples. Record the changes on Form 6, Used Oil Analysis Results, in standardized report form set (See Annex A6). Record the final percent viscosity increase on Form 4, Test Result Summary, in standardized report form set (See Annex A6).

13.14 Blowby Flow Rate Measurements-Plot blowby flow rate measurements on Form 10, Blowby Results & Plot, in standardized report form set (See Annex A6).

13.15 Oil Consumption Computation-Compute the oil consumption for the test as follows:

13.15.1 Annex A10

13.15.2 Determine the total fresh oil added to the engine during the initial oil leveling run and 10-h test periods in Step 8 of Annex A10. Enter the total in the end-of-test total column on Annex A10.

13.15.3 Determine the total amount of oil discarded during the 80-h test periods in Step 11 of Annex A10. Enter the total in the end-of-test total column on Annex A10.

13.15.4 Determine the computed oil level in milliliters at the end of the test, Step 13 in Annex A10. Enter the number in the end-of-test total column on Annex A10.

13.15.5 Add the values determined in 13.15.2 and 13.15.4, and subtract the value determined in 13.15.3. Enter the remainder, which is the amount of oil consumed in the test, in the blank for Step 14 in the Figure shown in A10.

13.16 Photographs of Test Parts-Take color photographs of the test parts for inclusion in the test report, as follows:

13.16.1 Photograph pistons after all ratings have been completed.

13.16.2 Do not coat the pistons with build-up oil (for preservation) before the photographs are taken. Do not re-install piston rings.

13.16.3 Photograph all six piston thrust sides in one shot. No piston labels required. (see 13.16.13)

13.16.4 Photograph all six piston anti-thrust sides in one shot. No piston labels required. (see 13.16.13)

13.16.11 Size the final piston photographs for inclusion in the test report so that the overall piston height is not less than 5 cm (2 in.), but small enough that three photographs can be mounted in a column on the 28-cm (11-in.) dimension of a 22 by 28-cm (8 1/2 by 11 in.) sheet of paper.

13.16.12 Assemble the photographs on two pages, with the thrust side photographs on one page, and the anti-thrust photographs on the other page.

13.16.13 Mount the photographs on each of the two pages with the reciprocating axes of the pistons parallel to the 28-cm (11-in.) dimension of the page. Arrange the photographs in two vertical columns of three each, with the No. 1 piston in the upper left corner of the page, No. 2 piston in the upper right corner, No. 3 piston in the center of the left column, etc.

13.17 Retention of Representative Test Parts-Retain for at least 6 months, all pistons, camshaft, and lifters.

13.18 Severity Adjustments-Calculate severity adjustments (SA) for results of non-reference engine oil tests. Use the control chart technique, described in A5, for determining the laboratory bias for % viscosity increase, piston skirt varnish, and weighted piston deposits. Enter the adjustments on Form 4, Test Result Summary, in standardized report form set (See A6).

13.19 Determination of Operational Validity-Determine and document the operational validity of every Sequence IIIF test conducted, according to the following:

13.19.1 Complete the report forms to substantiate that the test stand, engine build-up, installation of the engine on the test stand, and the test operation conformed to the procedures specified in this test method.

13.19.2 Inspect the test records for instances of downtime (excluding the initial oil level run of the test), and record any such instances on Form 13, Downtime & Outlier Report Form, in standardized report form set (See A6). Enter the total downtime on Form 13, Downtime & Outlier Report Form, in standardized report form set (See A6). If the total downtime exceeds 24 h, note on Form 1, in standardized report form set (See A6) that the test is invalid.

13.19.3 Sequence IIIF tests must average higher than 23 l/m (0.812 cu.ft./m) blowby rate for hours 1 through 26 in order to be considered a valid engine build.

13.19.4 If the end of test quality index value is below 0.000, conduct an engineering review of the test operations. The engineering review will be conducted by the test laboratory, and for reference oil tests the Test Monitoring Center. If needed, additional industry experts may be consulted. Document the results of the engineering review.

14. Report

14.1 Report Forms-Use the standardized report form set and data dictionary for reporting the test results for test oils and reference oils, and for summarizing the operational data.

14.2 Use of SI Units-Report all results in metric (SI) units. Record all measurements, with the exception of top and bottom ring gaps, in SI units.

14.3 Precision of Reported Units-Use Practice E 29 for rounding off data; use the rounding-off method. Report the data to the same precision as indicated in Annex A9.

14.4 Deviations from Test Operational Limits-*In addition to any deviations specified in 13.19, report all deviations from the specified test operational limits on a supplemental page. Include the test time, magnitude, and duration of the deviations. Include deviations from specified warm-up times, scheduled and unscheduled shutdowns, and shutdown procedures.*

15. Precision and Bias

15.1 Test precision is established on the basis of reference oil test results (for operationally-valid tests) monitored by the ASTM TMC. The data are reviewed semi-annually by the Sequence IIIF Surveillance Panel. Contact the ASTM TMC for current industry data.

15.1.1 Intermediate Precision (ip) (formerly called repeatability)- is the difference between two results obtained on the same test oil in the same laboratory and would, in the long run, in the normal and correct conduct of the test method, exceed the values shown in Table 12 in only one case in twenty. It should be noted that these repeat tests are not run in the same engines; that each engine is completely rebuilt before each test, and the engine is believed to be an important variable affecting the precision of the test.

15.1.2 Reproducibility (R)-The difference between two single and independent results obtained on the same oil by different operators working in different laboratories and would, in the long run, in the normal and correct conduct of the test method, exceed the values in Table 12 only one case in twenty.

15.1.3 Bias will be determined by applying an accepted statistical technique to reference oil test results, and when a significant bias is determined, a severity adjustment will be permitted for non-reference oil test results

16. Keywords

16.1 bearing weight loss; cam and lifter wear; deposits; engine oil; engine wear; high-temperature performance; oil consumption; oil thickening; oil viscosity; oxidation resistance; Sequence IIIF test; sludge; sludge deposition; spark-ignition automotive engine; varnish; varnish deposition

ANNEXES

(Mandatory Information)

A1. THE ROLE OF THE ASTM TEST MONITORING CENTER AND THE CALIBRATION PROGRAM

A1.1 Nature and Functions of the ASTM Test Monitoring Center (TMC)-The ASTM TMC is a non-profit organization located in Pittsburgh, PA and is staffed to administer engineering studies; conduct laboratory visits; perform statistical analyses of reference oil test data; blend, store, and ship reference oils; and provide the associated administrative functions to maintain the referencing calibration program for various lubricant tests as directed by Subcommittee D02.B and the Test Monitoring Board. The TMC coordinates its activities with the test sponsors, the test developers, the surveillance panels, and the testing laboratories.

A1.2 Rules of Operation of the ASTM TMC-The TMC operates in accordance with the ASTM Charter, the ASTM Bylaws, the Regulations Governing ASTM Technical Committees, the Bylaws Governing ASTM Committee D-2, and the Rules and Regulations Governing the ASTM Test Monitoring System.

A1.3 Management of the ASTM TMC-The management of the Test Monitoring System is vested in the Test Monitoring Board (TMB) elected by Subcommittee D02.B. The TMB selects the TMC Administrator who is responsible for directing the activities of the TMC staff.

A1.4 Operating Income of the ASTM TMC-The TMC operating income is obtained from fees levied on the reference oils supplied and on the calibration tests conducted. Fee schedules are established and reviewed by Subcommittee D02.B.

A1.5 Conducting a Reference Oil Test:

A1.5.1 For those laboratories which choose to utilize the services of the ASTM TMC in maintaining calibration of test stands, full-scale calibration testing shall be conducted at regular intervals. These full-scale tests are conducted using coded reference oils supplied by the ASTM TMC. It is a laboratory's responsibility to maintain the calibration in

accordance with the test procedure. It is also a laboratory's responsibility to keep the on-site reference oil inventory at or above the minimum level specified by the TMC test engineers.

A1.5.2 When laboratory personnel decide to run a reference calibration test, they shall request an oil code from the cognizant TMC engineer. Upon completion of the reference oil test, the data shall be sent in summary form (use TMC-acceptable forms) to the TMC by telephone facsimile transmission, or by some other method acceptable to the TMC. The TMC will review the data and contact the laboratory engineer to report the laboratory's calibration status. All reference oil tests, whether aborted, invalidated, or successfully completed, shall be reported to the TMC. Subsequent to sending the data in summary form to the TMC, the laboratory is required to submit to the TMC the written test report specified in the test procedure.

A1.6 New Laboratories-Laboratories wishing to become a part of the ASTM Test Monitoring System will be requested to conduct reference oil tests to ensure that the laboratory is using the proper testing techniques. Information concerning fees, laboratory inspection, reagents, testing practices, appropriate committee membership, and rater training can be obtained by contacting the TMC Administrator at ASTM Test Monitoring Center, 6555 Penn Ave. Pittsburgh, PA 15206.

A1.7 Introducing New Sequence IIIF Reference Oils-The calibrating reference oils produce various wear, oil thickening, and deposit characteristics. When new reference oils are selected, member laboratories will be requested to conduct their share of tests to enable the TMC to establish the proper industry average and test acceptance limits. The ASTM D02.B0.01 Sequence IIIF Surveillance Panel requires a minimum of four tests to be conducted prior to establishing the industry average and test acceptance targets for new reference oils. The TMC estimates that laboratories will normally be requested to run no more than one contributing test per year per test stand.

A1.8 TMC Information Letters:

A1.8.1 Occasionally, it is necessary to change the procedure, and notify the test laboratories of the change, prior to consideration of the change by either ASTM Subcommittee D02.B on Automotive Lubricants or ASTM Committee D-2 on Petroleum Products and Lubricants. In such a case, the TMC will issue an Information Letter. Subsequently, prior to each semi-annual Committee D-2 meeting, the accumulated Information Letters are balloted by ASTM Subcommittee D02.B. The ballot is reviewed at the ASTM Subcommittee D02.B meeting, and the actions taken are considered

at a meeting of ASTM Committee D-2. By this means, the Society due process procedures are applied to these Information Letters.

A1.8.2 The review of an Information Letter prior to its original issue will differ according to its nature. In the case of an Information Letter concerning a part number change which does not affect test results, the TMC is authorized to issue such a letter. Long-term studies by the surveillance panel to improve the test procedure through improved operation and hardware control may result in a recommendation to issue an Information Letter. If obvious procedural items affecting test results need immediate attention, the test sponsor and the TMC will issue an Information Letter and present the background and data to the surveillance panel for approval prior to the semi-annual ASTM Subcommittee D02.B meeting.

A1.8.3 Authority for the issuance of Information Letters was given by the ASTM Committee on Technical Committee Operations (COTCO) in 1984, as follows:

``COTCO recognizes that D-2 has a unique and complex situation. The use of Information Letters is approved providing each letter contains a disclaimer to the effect that such has not obtained ASTM consensus. These Information Letters should be moved to such consensus as rapidly as possible."

A1.8.4 Information Letters appertaining to this procedure issued prior to 1994-05-31 are incorporated in this test method. A listing of such Information Letters, and copies of the letters, may be obtained from the TMC. Information Letters issued subsequent to this date may also be obtained from the TMC.

A1.9 TMC Memoranda-In addition to the aforementioned Information Letters, supplementary memoranda are issued. These are developed by the TMC, and distributed to the Sequence IIIF Test Surveillance Panel and to participating laboratories. They convey such information as batch approvals for test parts or materials, clarification of the test procedure, notes and suggestions for the collection and analysis of special data that the TMC may request, or for any other pertinent matters having no direct effect on the test performance, results, or precision and bias.

A1.10 Precision Data-The TMC determines the current Sequence IIIF test precision by analyzing results of calibration tests conducted on reference oils. Current precision data can be obtained from the TMC.

A2. SEQUENCE IIIF ENGINE TEST PARTS

A2.1 Engine Test Parts Classification:

A2.1.1 Critical Parts-These are engine parts that are known to affect test severity. They will be identified with a serial number or a batch lot control number as supplied by the Central Parts Distributor.¹³ or Special Parts Supplier. Critical parts are listed in Table A2.1.

A2.1.2 Non-Production Parts-These are engine parts no longer available except through the Central Parts Distributor or by special order through the Test Developer.³⁷ Non-production parts are listed in Table A2.2.

A2.1.2.1 The engine parts supplied by the Central Parts Distributor and Special Parts Supplier are designated by numbers with a OHT or GMM prefixes.

A2.1.3 Service Parts Operations (SPO) Parts-These are most of the remaining engine parts, and are available through local General Motors dealer networks. SPO parts are listed in Table A2.3.

A2.1.3.1 The engine parts supplied through General Motors Service Parts Operations are designated by numbers containing five to eight digits.

A2.1.4 CPD Special Test Parts-These are engine parts that do not meet all the definitions of critical parts, non-production parts, or SPO parts, but shall be obtained from the Central Parts Distributor. CPD special test parts are listed in Table A2.4.

A2.1.4.1 The parts listed in this category are to include a brief description as to whether or not it is deemed to affect test severity and why it is not classified in one of the other three classifications.

A2.1.5 There are a few other engine parts that are available from other sources identified by footnotes in the following listing.

A2.2 Parts Procurement and Usage Guidelines:

A2.2.1 Use all parts on a first-in, first-out basis.

A2.2.2 The maximum order quantity of Critical Parts from the Central Parts Distributor.¹³ or Special Parts Supplier is limited to a sixty day supply for any given laboratory.

A2.2.3 Order quantities for non-production parts and SPO parts are also encouraged to be as low as is feasible to ensure a timely inventory turnover.

A2.2.4 The maximum inventory for critical parts and SPO parts in a given laboratory is a six month supply.

A2.2.5 Use all parts as received unless specific modifications are prescribed in the test method.

A2.2.6 All critical parts shipped from the Central Parts Distributor.¹³ or Special Parts Supplier will be accompanied by a critical parts accountability form (see Fig. A2.1). If any of these parts are rejected by a test laboratory, the reason for rejection shall be stated on the form. A copy shall be faxed monthly to the Test Monitoring Center, the Central Parts Distributor.¹³ or Special Parts Supplier, and the Test Developer. All required critical parts shall be saved for return shipment to the Central Parts Distributor.¹³ or Special Parts Supplier semi-annually on April 15 and October 15, or earlier as directed.

A2.2.7 No part number deviations from the current SPO Parts List are allowed except for depletion of old stock. Deviations shall be recorded in the supplementary test notes. The current SPO Qualified Parts List may differ from that in this test method, and the TMC should be contacted for the latest version of this test.

A2.3 Sequence IIIF Test Hardware Tracking-For each test, complete all hardware information in Fig. A2.2.

A2.3.1 For reference oil tests, complete the test results section of Fig. A2.2.

A2.3.2 For non-reference oil tests, the test results sections of Fig. A2.2 are optional.

A2.3.3 Record the information in Fig. A2.2 in an electronic format. Any software may be used, however, the data shall be able to be made available in a format readable by Microsoft Excel|Pr.

Annex A2. Table 1

Parts to be replaced in each build	Part #
Water Pump Gasket	24501565
Oil Pump Pick-up Tube Gasket	24501259
Oil Pan Gasket	24502397
Oil Pan Gasket	24502397
Rear Cover Gasket	24507388
Rocker Cover Gaskets	25532619
Cylinder Head Cup Plugs	9427698
Long Cylinder Head Bolts	25527831
Short Cylinder Head Bolts	25533811
Intake Plenum Gaskets	17113137
Gasket kit Intake Manif.(Lower)	12539094
Cam Bushings 1-4(Both are in engine kits)	3F028-09
Cam Bushings 2-3	3F028-10
Timing Gear	24505306
Timing Chain	24504668
PLATE, CM/SHF THR	OHT3F-011-1
Oil Filter Adapter Gasket	25534742
ARM, ROCKER WITH PIVOT BRG.	OHT3F-058-1
Rod/Main Bearings(in kit)	3F042-1
CAMSHAFT, SPECIAL TEST	OHT3F-008-6
GASKET, ENG FRT CVR	24502252
LIFTER, TEST, ACI W/FLAT (25338738A)	OHT3F-029-3
Pistons from run kit (x = run number)	OHT3F-050-Runx
Rings from run kit (x = 3, 4, or 5)	OHT3F—05x-1
PUSHROD, SPECIAL TEST	OHT3F-007-1
ROD, CONNECTING	24501696
SEAL, CR/SHF FRT OIL	24504098
SEAL, CR/SHF RR OIL(LIP SEAL)	25534760
VALVE, EXH(STD)	24507423
VALVE, INT(STD)	24507422
SEAL, EXH VLV STEM OIL(ID-WHITE STRIPE)	OHT3F-061-1
SEAL, INT VLV STEM OIL	OHT3F-060-1

Annex A2. Table 2

Parts to be replaced as necessary	Part#
Crankshaft	24502168
Oil Pump "Gearotor set"	24505433
Timing Cover	24502241
Intake Manifold	17113136
Harmonic Balancer	24507558
KEY, CM/SHF SPKT	24500618
Coolant out Gasket	24502433
ADAPTER, OIL FLTR(W/BYPASS VLV)	24501300
BEARING, BAL SHF FRT(PART OF 151)	24503193
BEARING, BAL SHF RR	
COVER, VLV RKR ARM(LEFT SIDE PLASTIC)	25534753
DAMPENER, TMG CHAIN(INCLS BOLT,RET RING)	24503893
GEAR, BAL SHF DRIVEN	24503524
GEAR, BAL SHF DRV	24504792
GROMMET, VLV RKR ARM CVR BOLT	25534749
KEY, CM/SHF SPKT	24500618
MAGNET, CM/SHF POSN SEN(2.383)	10456195
MANIFOLD, LWR INTAKE	24505728
PAN, OIL	OHT3F-073-1
SCREEN, O/PMP(W/SUC PIPE)	24505569
SEAL, OIL PAN DRN PLUG(O RING)	3536966
SEAL, PCV VLV(*KIT#5 P.N. 17113220)	
SEAL, PCV VLV(*KIT5)	
SHAFT, BAL(INCL 148)	24506557
SPROCKET, CM/SHF	24505306
SPROCKET, CR/SHF	OHT3F-036-1

A3. SEQUENCE IIIF BLUEPRINT LISTING

This section intentionally left blank at this time

A4. SEQUENCE IIIF TEST FUEL ANALYSIS

PRODUCT: **EEE Unleaded Gasoline**
 PRODUCT CODE: **HF003**

Batch No.: 99C-9
 TMO No.: _____
 Tank No.: 2014
 Analysis Date: 10/19/99
 Shipment Date: _____

TEST	METHOD	UNITS	FED Specs		SFC SPECIFICATIONS			RESULTS
			MIN	MAX	MIN	TARGET	MAX	
Distillation - IBP	ASTM D86	°F	75	95	75		95	83
5%		°F						109
10%		°F	120	135	120		135	124
20%		°F						147
30%		°F						171
40%		°F						200
50%		°F	200	230	200		230	221
60%		°F						232
70%		°F						243
80%		°F						261
90%		°F	305	325	305		325	315
95%		°F						334
Distillation - EP		°F		415			415	383
Recovery		vol %				Report		97.7
Residue		vol %				Report		1.0
Loss		vol %				Report		1.3
Gravity	ASTM D4052	°API	58.7	61.2	58.7		61.2	59.0
Density	ASTM D4052	kg/l			0.734		0.744	0.742
Reid Vapor Pressure	ASTM D323	psi	8.7	9.2	8.7		9.2	9.2
Reid Vapor Pressure	ASTM D5191	psi				Report		9.14
Carbon	ASTM D3343	wt fraction				Report		0.8652
Carbon	ASTM E191	wt fraction				Report		0.8613
Hydrogen	ASTM E191	wt fraction				Report		0.133
Hydrogen/Carbon ratio	ASTM E191	mole/mole				Report		1.840
Oxygen	ASTM D4815	wt %					0.05	<0.05
Sulfur	ASTM D4294	wt %		0.1			0.1	<0.015
Lead	ASTM D3237	g/gal		0.05			0.01	<0.01
Phosphorous	ASTM D3231	g/gal		0.005			0.005	<0.0008
Composition, aromatics	ASTM D1319	vol %		35.0			35.0	28.3
Composition, olefins	ASTM D1319	vol %		10.0			10.0	0.5
Composition, saturates	ASTM D1319	vol %				Report		71.2
Particulate matter	ASTM D5452	mg/l					1	0.6
Oxidation Stability	ASTM D525	minutes			240			>1000
Copper Corrosion	ASTM D130						1	1
Gum content, washed	ASTM D381	mg/100mls					5	1
Fuel Economy Numerator/C Density	ASTM E191				2401		2441	2431
C Factor	ASTM E191					Report		0.9982
Research Octane Number	ASTM D2699		93.0		95.0			98.5
Motor Octane Number	ASTM D2700					Report		89.7
Sensitivity			7.5		7.5			8.8
Net Heating Value, btu/lb	ASTM D3338	btu/lb				Report		18477
Net Heating Value, btu/lb	ASTM D240	btu/lb				Report		18457
Color	VISUAL	1.75 ptb				Report		Red

APPROVED BY: _____

ANALYST KMW

A5. SEQUENCE IIIF TEST CONTROL CHART TECHNIQUE FOR DEVELOPING AND APPLYING SEVERITY ADJUSTMENTS (SA)

Refer to "*The Lubricant Test Monitoring System*", available from the ASTM TMC, for information on the control chart technique and application of severity adjustments.

A6. SEQUENCE IIIF TEST REPORT Forms and Data Dictionary

Note: The actual report forms and data dictionary must be downloaded separately from the ASTM Test Monitoring Center Web Page at <http://tmc.astm.cmri.cmu.edu/> or can be obtained in hardcopy format from the TMC.

Sequence IIIF

Table of Contents

1.	Title / Validity Declaration Page	Form 1
2.	Summary of Test Method	Form 3
3.	Test Result Summary	Form 4
4.	Operational Summary	Form 5
6	5. Viscosity and ICP Analytical Test Results	Form
	6. Valve Lifter and Camshaft Wear Results	Form 7
	7. Summary of Oil Ring Land Deposit Rating	Form 8
	8. Summary of Weighted Piston Deposits	Form 9
	9. Blowby Values and Plot	Form 10
	10. Viscosity Increase Plot	Form 11
	11. Hardware Information	Form 12
	12. Downtime and Outlier Report Form	Form 13

Annex A7

Fig. A7.1 Air-to-Fuel ratio control flow chart

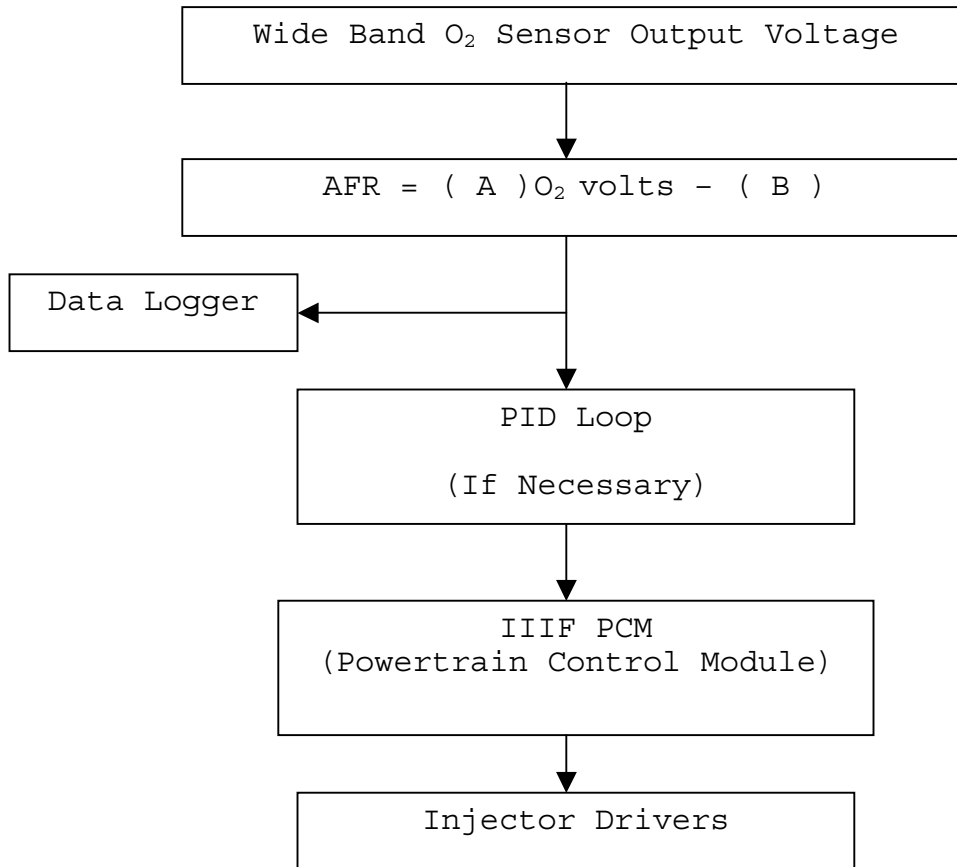

A & B derived from sensor calibration procedure and scaled to oscillating voltage from 100mv to 900mv input to PCM. Adjust B term as necessary during first hour of test condition to control at 15:1 air-to-fuel ratio.

Table A7.1 Sequence IIIIF Air-to-Fuel Equivalence Ratio Chart for Specified

Fuel (C H)x
1.860

Composition by Weight: %C %H Stoichiometric AFR = 14.530
86.50 13.50

Equivalence Ratios			Emissions by Volume (Dry)				Moisture
AFR	Lambda	Gamma	%O2	%H2	%CO	%CO2	%H2O
7.265	0.500	2.000	0.000	13.635	19.975	2.968	7.149
7.555	0.520	1.923	0.000	12.557	19.179	3.387	7.772
7.846	0.540	1.852	0.000	11.536	18.379	3.817	8.344
8.137	0.560	1.786	0.000	10.571	17.575	4.258	8.868
8.427	0.580	1.724	0.000	9.660	16.767	4.709	9.346
8.718	0.600	1.667	0.000	8.803	15.954	5.170	9.780
9.008	0.620	1.613	0.000	7.997	15.137	5.641	10.173
9.299	0.640	1.562	0.000	7.241	14.317	6.122	10.526
9.589	0.660	1.515	0.000	6.533	13.494	6.611	10.843
9.880	0.680	1.471	0.000	5.872	12.670	7.107	11.125
10.171	0.700	1.429	0.000	5.256	11.844	7.611	11.374
10.461	0.720	1.389	0.000	4.682	11.018	8.120	11.593
10.752	0.740	1.351	0.000	4.149	10.192	8.634	11.783
11.042	0.760	1.316	0.000	3.655	9.369	9.153	11.947
11.333	0.780	1.282	0.000	3.197	8.549	9.674	12.086
11.624	0.800	1.250	0.000	2.774	7.732	10.196	12.202
11.914	0.820	1.220	0.000	2.382	6.921	10.720	12.297
12.205	0.840	1.190	0.000	2.021	6.116	11.243	12.373
12.495	0.860	1.163	0.000	1.689	5.319	11.765	12.432
12.786	0.880	1.136	0.000	1.383	4.529	12.285	12.474
13.077	0.900	1.111	0.000	1.101	3.748	12.802	12.502
13.367	0.920	1.087	0.000	0.842	2.977	13.315	12.517
13.658	0.940	1.064	0.000	0.604	2.216	13.824	12.519
13.948	0.960	1.042	0.000	0.385	1.466	14.327	12.511
14.239	0.980	1.020	0.000	0.184	0.727	14.825	12.494
14.530	1.000	1.000	0.000	0.000	0.000	15.317	12.467
14.820	1.020	0.980	0.439	0.000	0.000	14.996	12.238
15.111	1.040	0.962	0.861	0.000	0.000	14.688	12.017
15.401	1.060	0.943	1.265	0.000	0.000	14.392	11.803
15.692	1.080	0.926	1.653	0.000	0.000	14.108	11.597
15.982	1.100	0.909	2.027	0.000	0.000	13.835	11.398
16.273	1.120	0.893	2.386	0.000	0.000	13.572	11.206
16.564	1.140	0.877	2.732	0.000	0.000	13.320	11.021
16.854	1.160	0.862	3.065	0.000	0.000	13.076	10.841
17.145	1.180	0.847	3.386	0.000	0.000	12.841	10.667
17.435	1.200	0.833	3.696	0.000	0.000	12.614	10.498
17.726	1.220	0.820	3.995	0.000	0.000	12.396	10.335
18.017	1.240	0.806	4.284	0.000	0.000	12.185	10.177
18.307	1.260	0.794	4.563	0.000	0.000	11.980	10.024
18.598	1.280	0.781	4.833	0.000	0.000	11.783	9.875
18.888	1.300	0.769	5.094	0.000	0.000	11.592	9.730
19.179	1.320	0.758	5.347	0.000	0.000	11.407	9.590
19.470	1.340	0.746	5.592	0.000	0.000	11.228	9.453
19.760	1.360	0.735	5.830	0.000	0.000	11.054	9.321
20.051	1.380	0.725	6.060	0.000	0.000	10.886	9.192
20.341	1.400	0.714	6.283	0.000	0.000	10.723	9.067
20.632	1.420	0.704	6.500	0.000	0.000	10.564	8.945
20.923	1.440	0.694	6.710	0.000	0.000	10.410	8.826
21.213	1.460	0.685	6.915	0.000	0.000	10.261	8.710
21.504	1.480	0.676	7.113	0.000	0.000	10.116	8.598
21.794	1.500	0.667	7.306	0.000	0.000	9.975	8.488

Theoretical Exhaust Gas Relationships for Specified EEE Test Fuel

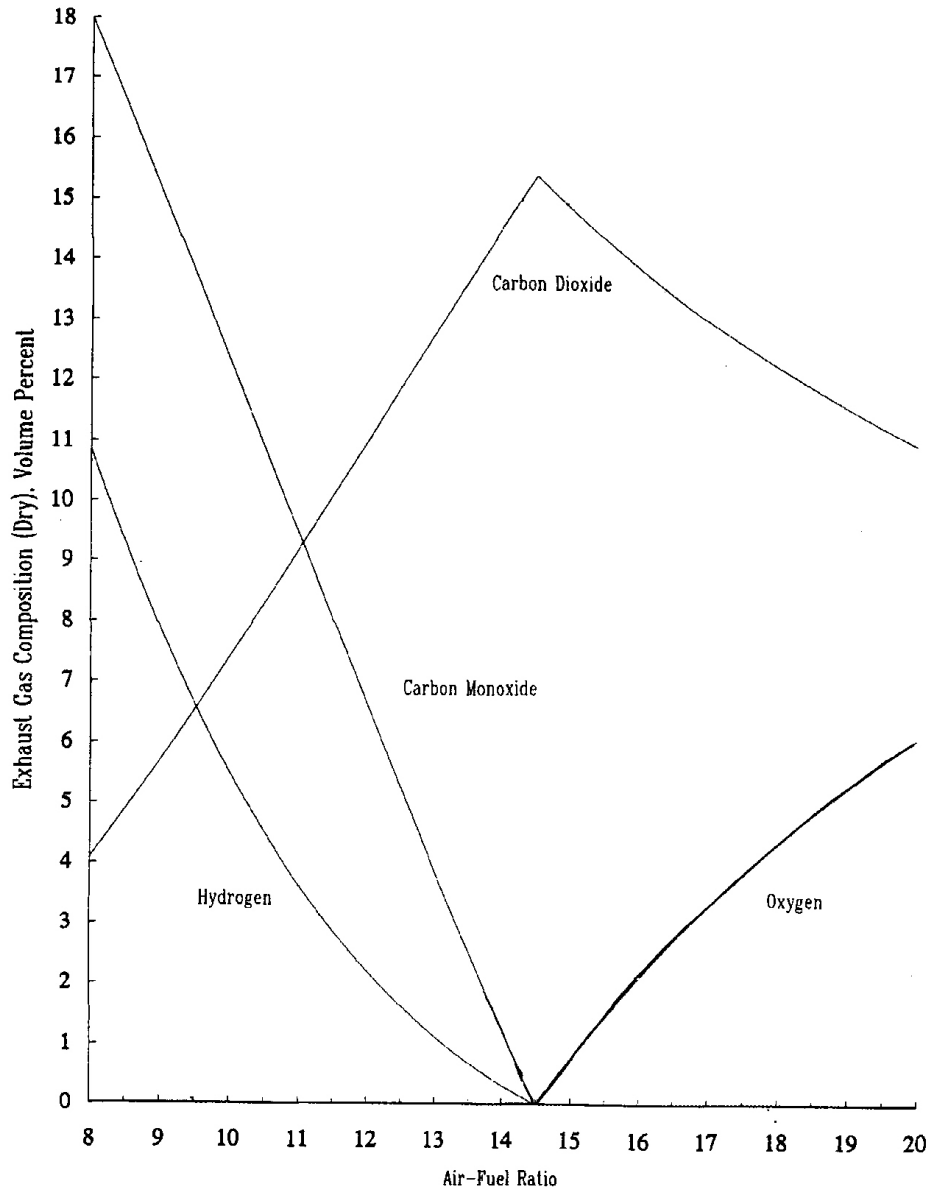

Note - Use corrected values for oxygen and carbon dioxide volumes; see text

Fig. A7.2 Sequence III F Air-to-Fuel Ratio for Specified Fuel ($\text{CH}_{1.880}$)_x

Sequence IIIF Operating Procedure and Specifications

Sequence IIIF On-Test Control Settings

Test Parameter	Setpoint	Units	Acronym
Engine Speed	3600	RPM	SPEED
Dyno Torque	200	Nm	LOAD

Temperature

Oil Filter Block	155	°C	TOLFLT
Oil Sump	R	°C	TOLSMP
Engine Coolant Out	122	°C	TCLEO
Engine Coolant In	R	°C	TCLEI
Inlet Air Adapter	27	°C	TAIRIN
Dewpoint	16.1	°C	DEWPT
Breather Tube Coolant Outlet	40	°C	TCOND
Blowby Gas Outlet	R	°C	TBLBY
Fuel	R	°C	TFUELIN
Ambient Air	R	°C	TAMB
Right Exhaust Manifold Coolant Out	R	°C	TMMRO
Left Exhaust Manifold Coolant Out	R	°C	TMMLO

Pressure

Oil Filter Inlet	R	kPa	POLFTR
Oil Gallery	R	kPa	POLENG
Fuel	365	kPa	PFUEL
Inlet Air Adapter *	0.05	kPa	PAIRIN
Intake Manifold Vacuum	R	kPa	PINVAC
Crankcase	R	kPa	PCC
Exhaust Back Pressure Right	6	kPa	PEXHBR
Exhaust Back Pressure Left	6	kPa	PEXHBL

Flow

Engine Coolant	160	L/m	FCLEO
Breather Tube	10	L/m	FCOND
Exhaust Manifold Left	8	L/m	FMML
Exhaust Manifold Right	8	L/m	FMMR
Engine Oil Cooler	12	L/m	FOXHC

AFR

Air-to-Fuel Ratio Left	15.0:1	:1	AFRL
Air-to-Fuel Ratio Right	15.0:1	:1	AFRR

* Future Consideration

Sequence IIF Test States

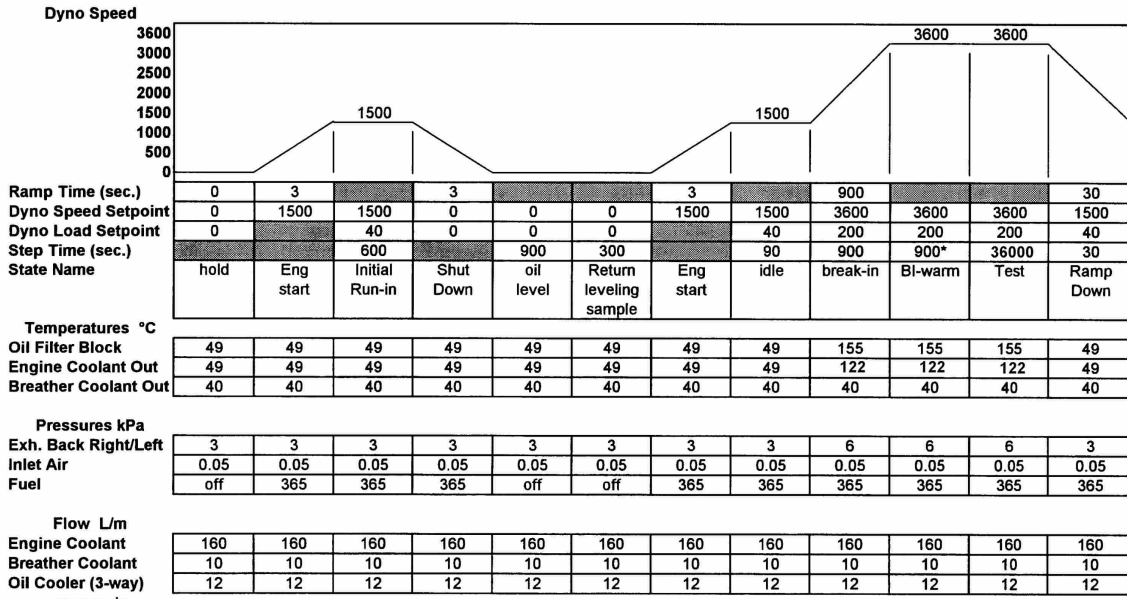

* Typical warm-up transition time to on test condition about 8 minutes.
 ** Typical warm-up transition time to on test condition about 18 minutes.
 All ramp times are linear with respect to dyno speed and load settings.
 All temp., press., & flow settings are setpoint changes between states. Control systems should allow for overshoot and stabilization.

Sequence III F Test States

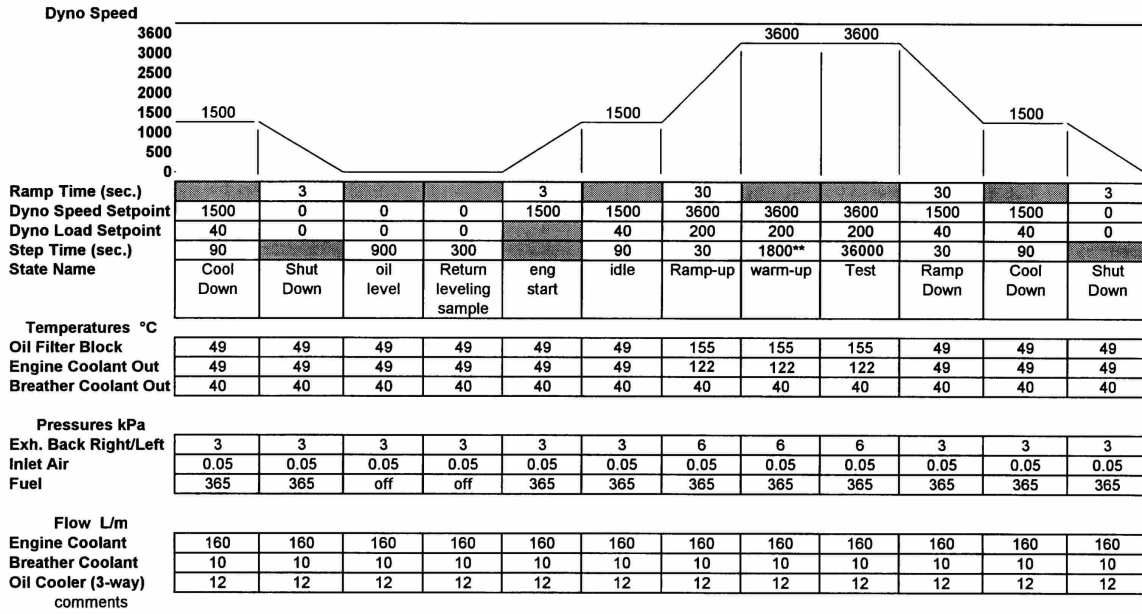

Annex A9
Sequence IIIIF Quality Index U&L Values
(Effective 10/4/00)

Controlled Parameters	Quality Index U&L Values	
	L	U
Speed	3595	3605
Load	199.02	200.98
Air-to-Fuel Ratio	14.87	15.13
Condenser Coolant Outlet Temperature	39.77	40.23
Engine Coolant Outlet Temperature	121.54	122.46
Oil Filter Block Temperature	154.58	155.42
Exhaust Back Pressure	5.92	6.08
Intake Air Pressure	0.041	0.059
Condenser Coolant Flow	9.9	10.1
Engine Coolant Flow	158.57	161.43

Sequence IIIIF Required Resolution for Data Acquisition

Controlled Parameters	Units	Required Resolution*
Speed	r/min	5.0
Load	N•m	5.1
Air-to-Fuel Ratio	--	5.2
Condenser Coolant Outlet Temperature	°C	5.1
Engine Coolant Outlet Temperature	°C	5.1
Oil Filter Block Temperature	°C	5.1
Exhaust Back Pressure	kPa	5.2
Intake Air Pressure	kPa	5.3
Condenser Coolant Flow	L/min	5.2
Engine Coolant Flow	L/min	5.1

*Decimal point is counted in format.

Maximum System Time Response - *for controlled (QI) parameters only.*

Speed - 0.10s
Torque - 0.60s
Coolant Flow - 8.0s
Intake Air Pressure - 0.75s
Exhaust Backpressure - 1.20s
Temperatures - 2.40s

Annex A10
Engine Oil Level Data Sheet

TEST CELL _____
ENG # _____

TEST # _____
DATE _____

SEQ. IIIIF OIL LEVEL, AND CONSUMPTION
OIL LEVEL AT END OF TIMING RUN

INITIAL FILL=5500 ML

REMOVE 472ML PURGE SAMPLE
REMOVE 472ML LEVELING SAMPLE
REMOVE 236ML ANALYSIS SAMPLE
REMOVE 59ML ANALYSIS SAMPLE
REPLACE 472ML PURGE SAMPLE
ADD 236ML TO REPLACE SAMPLE
ADD 59ML TO REPLACE SAMPLE
ADD 472ML NEW OIL

OIL LEVEL AFTER DRAIN DOWN (ML)
LEVELING SAMPLE ADDED (ML)
LEVELING SAMPLE DISCARDED (ML)
RESULTING DIPSTICK LEVEL (MM)
COMPUTED OIL LEVEL ML

PERFORMED BY _____
ADDITIONAL OIL ADDED (ML) _____
OIL CONSUMPTION _____

TOTAL NEW OIL ADDED DURING TEST TIME -TOTAL DISCARDED+LEVEL AT EOT= TOTAL AMOUNT OF OIL CONSUMED DURING TEST

ML

	TEST	HOURS							EOT
TMNG RN	10	20	30	40	50	60	70	80	TOTAL
									472
	#VALUE!	#VALUE!	#VALUE!	#VALUE!	#VALUE!	#VALUE!	#VALUE!	#VALUE!	#VALUE!
	#VALUE!	#VALUE!	#VALUE!	#VALUE!	#VALUE!	#VALUE!	#VALUE!	#VALUE!	#VALUE!
	#VALUE!	#VALUE!	#VALUE!	#VALUE!	#VALUE!	#VALUE!	#VALUE!	#VALUE!	#VALUE!
	#VALUE!	#VALUE!	#VALUE!	#VALUE!	#VALUE!	#VALUE!	#VALUE!	#VALUE!	#VALUE!

#VALUE!