

This document is not an ASTM standard; it is under consideration within an ASTM technical committee but has not received all approvals required to become an ASTM standard. You agree not to reproduce or circulate or quote, in whole or in part, this document outside of ASTM Committee/Society activities, or submit it to any other organization or standards bodies (whether national, international, or other) except with the approval of the Chairman of the Committee having jurisdiction and the written authorization of the President of the Society. If you do not agree with these conditions please immediately destroy all copies of the document. Copyright ASTM International, 100 Barr Harbor Drive, West Conshohocken, PA 19428. All Rights Reserved.



Designation: DXXXX – XX

Date: 12/14/15
To: Subcommittee D02.B0
Tech Contact: E. A. Hap Thompson
Work Item #: WK50204
Ballot Action: Revision of DXXXX-XX
Rationale: A new heavy duty engine oil classification has been issued so this is a new standard.

Standard Test Method for Evaluation of Diesel Engine Oils in T-13 Diesel Engine¹²

This standard is issued under the fixed designation DXXXX; the number immediately following the designation indicates the year of original adoption or, in the case of revision, the year of last revision. A number in parentheses indicates the year of last reapproval. A superscript epsilon (ϵ) indicates an editorial change since the last revision or reapproval.

1. Scope

1.1 This test method covers an engine test procedure for evaluating diesel engine oils for oxidation performance characteristics in an engine equipped with exhaust gas recirculation and running on ultra-low sulfur diesel fuel.² This test method is commonly referred to as the Volvo T-13.

1.2 The values stated in SI units are to be regarded as standard. No other units of measurement are included in this standard.

1.2.1 *Exception*—Where there is no direct SI equivalent, such as the units for screw threads, National Pipe Threads/diameters, tubing size, and single source supply equipment specifications.

1.3 *This standard does not purport to address all of the safety concerns, if any, associated with its use. It is the responsibility of the user of this standard to establish appropriate safety and health practices and determine the applicability of regulatory limitations prior to use. See Annex A10 for specific safety precautions.*

2. Referenced Documents

2.1 ASTM Standards:³

- D86 Test Method for Distillation of Petroleum Products at Atmospheric Pressure
- D93 Test Methods for Flash Point by Pensky-Martens Closed Cup Tester
- D97 Test Method for Pour Point of Petroleum Products
- D130 Test Method for Corrosiveness to Copper from Petroleum Products by Copper Strip Test
- D235 Specification for Mineral Spirits (Petroleum Spirits) (Hydrocarbon Dry Cleaning Solvent)
- D287 Test Method for API Gravity of Crude Petroleum and Petroleum Products (Hydrometer Method)
- D445 Test Method for Kinematic Viscosity of Transparent and Opaque Liquids (and Calculation of Dynamic Viscosity)
- D482 Test Method for Ash from Petroleum Products

¹ This test method is under the jurisdiction of ASTM Committee D02 on Petroleum Products and Lubricants and is the direct responsibility of Subcommittee D02.B0 on Automotive Lubricants.

Current edition approved May 1, 2013. Published June 2013. Originally approved in 2008. Last previous edition approved in 2012 as D7422 – 12. DOI: 10.1520/D7422-13.

² The ASTM Test Monitoring Center will update changes in this test method by means of Information Letters. Information letters may be obtained from the ASTM Test Monitoring Center, 6555 Penn Avenue, Pittsburgh, PA 15206-4489, Attention: Administrator. This edition incorporates revisions in all Information Letters through No. XX–X.

³ For referenced ASTM standards, visit the ASTM website, www.astm.org, or contact ASTM Customer Service at service@astm.org. For *Annual Book of ASTM Standards* volume information, refer to the standard's Document Summary page on the ASTM website.

- D524 Test Method for Ramsbottom Carbon Residue of Petroleum Products
 - D613 Test Method for Cetane Number of Diesel Fuel Oil
 - D664 Test Method for Acid Number of Petroleum Products by Potentiometric Titration
 - D976 Test Method for Calculated Cetane Index of Distillate Fuels
 - D1319 Test Method for Hydrocarbon Types in Liquid Petroleum Products by Fluorescent Indicator Adsorption
 - D2274 Test Method for Oxidation Stability of Distillate Fuel Oil (Accelerated Method)
 - D2500 Test Method for Cloud Point of Petroleum Products
 - D2622 Test Method for Sulfur in Petroleum Products by Wavelength Dispersive X-ray Fluorescence Spectrometry
 - D2709 Test Method for Water and Sediment in Middle Distillate Fuels by Centrifuge
 - D3338 Test Method for Estimation of Net Heat of Combustion of Aviation Fuels
 - D4052 Test Method for Density, Relative Density, and API Gravity of Liquids by Digital Density Meter
 - D4175 Terminology Relating to Petroleum, Petroleum Products, and Lubricants
 - D4294 Test Method for Sulfur in Petroleum and Petroleum Products by Energy Dispersive X-ray Fluorescence Spectrometry
 - D4485 Specification for Performance of Active API Service Category Engine Oils
 - D4739 Test Method for Base Number Determination by Potentiometric Hydrochloric Acid Titration
 - D5185 Test Method for Determination of Additive Elements, Wear Metals, and Contaminants in Used Lubricating Oils and Determination of Selected Elements in Base Oils by Inductively Coupled Plasma Atomic Emission Spectrometry (ICP-AES)
 - D5186 Test Method for Determination of the Aromatic Content and Polynuclear Aromatic Content of Diesel Fuels and Aviation Turbine Fuels by Supercritical Fluid Chromatography
 - D5453 Test Method for Determination of Total Sulfur in Light Hydrocarbons, Spark Ignition Engine Fuel, Diesel Engine Fuel, and Engine Oil by Ultraviolet Fluorescence
 - D5967 Test Method for Evaluation of Diesel Engine Oils in T-8 Diesel Engine
 - D6079 Test Method for Evaluating Lubricity of Diesel Fuels by the High-Frequency Reciprocating Rig (HFRR)
 - E29 Practice for Using Significant Digits in Test Data to Determine Conformance with Specifications
 - E178 Practice for Dealing with Outlying Observations
- 2.2 *National Archives and Records Administration*.⁴
- Code of Federal Regulations Title 40 Part 86.310-79

3. Terminology

3.1 Definitions:

3.1.1 *blind reference oil, n*—a reference oil, the identity of which is unknown by the test facility.

3.1.1.1 *Discussion*—This is coded reference oil that is submitted by a source independent from the test facility.

D4175

3.1.2 *blowby, n*—in internal combustion engines, that portion of the combustion products and unburned air/fuel mixture that leaks past piston rings into the engine crankcase during operation.

3.1.3 *calibrate, v*—to determine the indication or output of a device (e.g., thermometer, manometer, engine) with respect to that of a standard.

3.1.4 *candidate oil, n*—an oil that is intended to have the performance characteristics necessary to satisfy a specification and is intended to be tested against that specification. **D4175**

3.1.5 *exhaust gas recirculation (EGR), n*—the mixing of exhaust gas with intake air to reduce the formation of nitrogen oxides (NO_x). **D4175**

3.1.6 *heavy-duty, adj*—in internal combustion engine operation, characterized by average speeds, power output and internal temperatures that are close to the potential maximums. **D4175**

3.1.7 *heavy-duty engine, n*—in internal combustion engine types, one that is designed to allow operation continuously at or close to its peak output.

3.1.8 *non-reference oil, n*—any oil other than a reference oil; such as a research formulation, commercial oil or candidate oil. **D4175**

⁴ Available from U.S. Government Printing Office Superintendent of Documents, 732 N. Capitol St., NW, Mail Stop: SDE, Washington, DC 20401, <http://www.access.gpo.gov>.

3.1.9 *non-standard test, n*—a test that is not conducted in conformance with the requirements in the standard test method; such as running on an uncalibrated test stand, using different test equipment, applying different equipment assembly procedures, or using modified operating conditions. **D4175**

3.1.10 *oxidation, n—of engine oil*, the reaction of the oil with an electron acceptor, generally oxygen, that can produce deleterious acidic or resinous materials often manifested as sludge formation, varnish formation, viscosity increase, or corrosion, or combination thereof.

3.1.11 *reference oil, n*—an oil of known performance characteristics, used as a basis for comparison.

3.1.11.1 *Discussion*—Reference oils are used to calibrate testing facilities, to compare the performance of other oils, or to evaluate other materials (such as seals) that interact with oils. **D4175**

3.1.12 *sludge, n—in internal combustion engines*, a deposit, principally composed of insoluble resins and oxidation products from fuel combustion and the lubricant that does not drain from engine parts but can be removed by wiping with a cloth. **D4175**

3.1.13 *standard test, n*—a test on a calibrated test stand, using the prescribed equipment in accordance with the requirements in the test method, and conducted in accordance with the specified operating conditions.

3.1.14 *test parameter, n*—a specified component, property, or condition of a test procedure.

3.1.14.1 *Discussion*—Examples of *components* are fuel, lubricant, reagent, cleaner, and sealer; of *properties* are density, temperature, humidity, pressure, and viscosity; and of *conditions* are flow rate, time, speed, volume, length, and power. **D4175**

3.1.15 *varnish, n—in internal combustion engines*, a hard, dry, generally lustrous deposit that can be removed by solvents but not by wiping with a cloth. **D4175**

3.1.16 *wear, n*—the loss of material from a surface, generally occurring between two surfaces in relative motion, and resulting from mechanical or chemical action or a combination of both. **D4175**

4. Summary of Test Method

4.1 The test operation involves use of a Volvo/Mack D13/MP8 diesel engine with Exhaust Gas Recirculation (EGR). A warm-up and a 1 h break-in are followed by a single-phase test consisting of 360 h at 1500 r/min and fuel flow of 68.0 kg/h.

4.2 Take oil samples periodically and analyze for viscosity increase, oxidation and wear metals content.

4.3 Rebuild the engine prior to each test. Disassemble, solvent-clean, measure, and rebuild, the engine power section using all new pistons, rings, cylinder liners, and connecting rod bearings, in strict accordance with furnished specifications.

4.4 Solvent-clean the engine crankcase and replace worn or defective parts.

4.5 Equip the test stand with appropriate accessories for controlling speed, fuel flow, and various engine operating conditions.

5. Significance and Use

5.1 This test method was developed to evaluate the oxidation resistance performance of engine oils in turbocharged and intercooled four-cycle diesel engines equipped with EGR and running on ultra-low sulfur diesel fuel. Obtain results from used oil analysis and component measurements before and after test.

5.2 The test method may be used for engine oil specification acceptance when all details of the procedure are followed.

6. Apparatus

6.1 General Description:

6.1.1 The test engine is a Volvo/Mack D13/MP8, electronically controlled fuel injection with six electronic unit injectors. It is an open-chamber, in-line, six-cylinder, four-stroke, turbocharged, charge air-cooled, and compression ignition engine.

6.1.2 The ambient laboratory atmosphere shall be relatively free of dirt and other contaminants as required by good laboratory standards. Filtering air, controlling temperature, and controlling humidity in the engine buildup area helps prevent accumulation of dirt and other contaminants on engine parts and aids in measuring and selecting parts for assembly.

6.2 Test Engine:

6.2.1 *Volvo T-13 Test Engine*—The engine is available from TEI. A list of test parts to be replaced for each test is shown in [Table A6.1](#). Use test parts on a first-in/first-out basis. A complete engine parts list is available from the TMC website.

6.2.1.1 The engine should be mounted with the flywheel perpendicular to the floor and tilted 4° toward the intake manifold side of the engine.

6.2.2 Engine Cooling System:

6.2.2.1 Use a new Volvo coolant filter shown in [Table A6.1](#), every test, to limit scaling in the cooling system. Pressurize the system at the expansion tank to 103 kPa. Use the coolant described in [7.3.1](#).

6.2.2.2 Remove the thermostat and replace it with a sleeve (P/N 21474103) and seal (P/N 1549651).

6.2.2.3 Use a closed-loop, pressurized external engine cooling system composed of a heat exchanger, reservoir, and water-out temperature control valve. The system shall prevent air entrainment and control jacket temperatures within the specified limit. Install a sight glass between the engine and the cooling tower to check for air entrainment and uniform flow in an effort to observe and prevent localized boiling.

6.2.2.4 Use a closed-loop, pressurized external EGR cooling system composed of a heat exchanger, reservoir, and coolant-out temperature control valve. The system shall prevent air entrainment and control jacket temperatures within the specified limit. Install a sight glass between the EGR cooler and the cooling tower to check for air entrainment and uniform flow in an effort to observe and prevent localized boiling. The coolant flow direction is to be parallel (concurrent) with the EGR gas flow.

6.2.3 Auxiliary Oil System:

6.2.3.1 To maintain a constant oil level in the pan, provide an additional 9.5 L sump by using a separate closed tank connected to the sump. Circulate oil through the tank with an auxiliary pump. The system schematic is shown in Fig. A1.1. The supply line to the tank from the sump is to have an inside diameter of 16 mm. The return line from the tank to the sump is to have an inside diameter of 12 mm. Use a vent line with a minimum inside diameter of 13 mm. Return line from external oil vessel connected to center of compressor block-off plate. Refer to Fig. A5.2. Vent of external oil vessel connected to cylinder head cover between cylinder 1 and cylinder 2 (see attached). Max length of supply and return line combined: 5.4 m (18 ft).

6.2.3.2 Use a front mount steel oil pan (P/N 21585801) with gasket (P/N 21293367). Remove the oil level sensor. Locate the auxiliary oil system suction line on the exhaust side of the oil pan, down from the oil pan rail 245 mm, and back from the front of the pan 157 mm. Refer to [Fig. A5.3](#). Connect the auxiliary oil system return line to the air compressor block off plate on the rear timing gear cover. Connect the auxiliary oil scale vent line to the top of the auxiliary oil sump bucket and the valve cover.

6.2.3.3 Use Viking Pump Model SG053514 as the auxiliary oil pumps. Pump speed is specified as 1725 r/min.⁵

6.2.3.4 Oil Sampling Port: Size: ¼ in. (No. 4 Aeroquip or equivalent), Max. Length: 2.43 m, Port Location on side of oil filter housing. Refer to Fig. A5.4

6.2.3.5 Pressurized Oil Filling Connection, see Fig. A5.5, between the oil cooler and the oil filter housing.

6.2.4 Oil Cooling System:

6.2.4.1 Use a US07 Oil Filter Housing (P/N 21183257) and remove the oil thermostat. See Figures A6.2 and A6.3.

6.2.5 *Blowby Meter*—Use a meter capable of providing data at a minimum frequency of 6 min. To prevent blowby condensate from draining back into the engine, ensure the blowby line has a downward slope to a collection bucket. Ensure the collection bucket has a minimum volume of 18.9 L. Locate the blowby meter downstream of the collection bucket. The slope of the blowby line downstream of the collection bucket is unspecified.

6.2.6 *Air Supply and Filtration*—Use an air filter element and a filter housing appropriate for a heavy duty engine. Install an adjustable valve in the inlet air system at least 2 pipe diameters before any temperature, pressure and humidity measurement devices. Use the valve to maintain inlet air restriction within required specifications.

6.2.6.1 If so equipped remove the inlet air pre-heater element and its housing and replace it with a non heater equipped housing. The part number for the non-heated housing is 20730387. This unit also requires bolts (P/N 965184), washers (P/N

⁵ The sole source of supply of the apparatus known to the committee at this time is Viking Pump, Inc., a unit of IDEX Corporation, 406 State Street, P.O. Box 8, Cedar Falls, IA 50613-0008. If you are aware of alternative suppliers, please provide this information to ASTM International Headquarters. Your comments will receive careful consideration at a meeting of the responsible technical committee,¹ which you may attend.

976944) and gaskets (P/N 3979639).

6.2.7 *Fuel Supply*—Heating, cooling, or both of the fuel supply may be required, and a recommended system is shown in Fig. A5.35.

6.2.8 *Intake Manifold Temperature Control*—Use an intercooler to control intake manifold temperature. Intercooler shall meet the following specifications: pressure drop at test conditions ≤ 5 kPa, provide enough cooling capacity to maintain specified Intake Manifold temperature, and equipped with drain to remove condensate.

6.2.9 *Fuel Pressure Regulator*—Use a P/N 691GC227M2 fuel pressure regulator.

6.2.10 *Engine Control Module (ECM)*— Load the test flash file 357309A59 T13 OFFICIAL FINAL Oct 2014 30 Inlet Air.

6.2.11 *Exhaust Valvetrain (Rocker Arms and Rocker Arm Shaft)* Use PVD coated exhaust rocker arms (P/N 21474103) with PVD coated rocker arm shaft (P/N 21534995).

6.2.12 *Camshaft*- Use a non-engine brake camshaft (P/N 21219818) with a Dummy Solenoid Valve (P/N 21105100).

6.2.13 *Oil mist separator speed sensor* Use Detroit Diesel P/N A0061535528 speed sensor with Detroit Diesel P/N A4720180340 bracket and Detroit Diesel P/N A0001506336 connector.

6.2.14 Compressor Block off Plate, use Volvo Penta P/N 21226107.

6.2.15 Turbocharger inlet rubber hose P/N 21659720.

6.2.16 Cool the crank damper with an appropriate method (a fan has been known to cool the damper).

6.2.17 Injector (6), use P/N 22027808. Use graphite paste P/N 85134750 for installation.

6.2.18 Turbocharger, P/N 85136177 with gasket with large opening P/N 20781146

6.2.19 Oil Cooler, ITT Model SSCF 5-160-03-014-004 two pass, all stainless steel; remove cooler core and baffle from engine (right side); plumb the cooler with 1in. (No. 16 Aeroquip or equivalent) flex lines with a combined max length to and from cooler to be 91.4 cm. Plumb the oil line to the shell side of the cooler and plumb process water to the tube side of the cooler.

6.2.20 Remove the vanes and cartridge from fuel and steering pump assembly.

6.2.21 Use flywheel, P/N 20941525 21514067.

6.2.22 Use Volvo/Mack Valve Cover P/N 20728586.

6.2.23 Crank pulley P/N 20799474, fan pulley P/N 20872502, belt idler (including pulley) P/N 20582550, belt tensioner P/N 21779276, belt P/N 88GB447P615 for correct water pump speed.

6.2.24 Leave the ambient temperature sensor disconnected.

6.2.25 Remove after treatment fuel doser and install connector jumper. Run with fault codes as shown in A9.

6.2.26 *EGR Cooler and Coolant Passage Cover*- Modify the coolant passage cover as show in Fig. A5.35. Use the fabricated EGR cooler adapter shown in Fig. A5.36 to connect the EGR cooler inlet to the closed loop external EGR coolant system specified in 6.2.2.4.

6.2.27 Fuel filter housing 21336013

6.2.28 Fuel Filter P/N 20972295

6.2.29 Fuel Water Separator P/N 21380521 (plastic bowl/drain P/N 21337071)

6.2.30 CO₂ Intake and Exhaust Measurements: Same probe specifications as Mack T-12; Cool sample to a Dew Point ≤ 5 °C

TABLE 1 Test Conditions

Parameters	Limits
Time, h	360
Controlled Parameters^A	
Speed, r/min	1500
Fuel flow kg/h	68
Coolant Out Temp., °C	110
Oil Gallery Temp., °C	130
Inlet Air Temp., °C	30
Inlet Manifold Temp., °C	78
EGR Gas Out Temp., °C	120
Fuel In Temp., °C	35
Inlet Air Pressure, kPaA	94
Inlet Manifold Pressure, kPaG	232 ± 5
Ranged Parameters^B	
Intake CO2	2.01 to 2.11
Engine Coolant Blanket Pressure, kPaG	99 to 107
EGR Coolant Blanket Pressure, kPaG	99 to 140
Crankcase Pressure, kPa	-0.3 to 0.3
Uncontrolled Parameters	
Load, N-m	2200
Exhaust CO2, %	Record
Coolant In Temp., °C	Record
Crankcase Pressure, kPa	Record
Pre-Turbine Temp. (F), °C	Record
Pre-Turbine Temp. (R), °C	Record
Tailpipe Temp., °C	Record
Main Gallery Oil Pressure, kPa	Record
Oil Sump Temp., °C	Record
Oil Jet Temp., °C	Record
Oil Jet Pressure, kPa	Record
Fuel Gallery Temp., °C	Record
Fuel Gallery Pressure, kPa	Record
Intercooler Out Temp., °C	Record
Intercooler Out Pressure, kPa	Record
Compressor Out Temp., °C	Record
Compressor Out Pressure, kPa	Record
Room Temp., °C	Record
EGR Position, %	Record
VGT Position, %	Record
Throttle Position, %	Record
Blowby, L/min	Record
Inlet Air Dew Point, °C	Record

^A All control parameters shall be targeted at the mean indicated.

^B All ranged parameters shall fall within the specified ranges.

7. Engine Fluids

7.1 *Test Oil*—Approximately 76 L of test oil are required for the test.

7.2 *Test Fuel*—Obtain the ultra-low sulfur diesel (ULSD) test fuel from the supplier shown in A6.5. The required fuel properties and tolerances are shown in Table 2.

TABLE 2 ULSD Fuel Specification

Property	Specification	Test Method
Additives	Lubricity additive only	...
Distillation Range, °C, 90 %	293–332	ASTM D86
Specific Gravity	0.840–0.855	ASTM D4052
API Gravity	34–37	ASTM D4052
Corrosion, 3 h at 50 °C	1 max	ASTM D130
Sulfur, g/kg	7–15	ASTM D5453 or equivalent
Flash Point, °C	54 min	ASTM D93
Pour Point, °C	–18 max	ASTM D97
Cloud Point, °C	Report	ASTM D2500
Viscosity at 40 °C, mm ² /s	2.0–2.6	ASTM D445
Ash, mass fraction %	0.005 max	ASTM D482
Carbon Residue on 10 % Bottoms	0.35 max	ASTM D524
Net Heat of Combustion	Report	ASTM D3338
Water and Sediment, volume %	0.05 max	ASTM D2709
Total Acid Number	0.05 max	ASTM D664
Strong Acid Number	0 max	ASTM D664
Cetane Index	Report	ASTM D976
Cetane Number	43–47	ASTM D613
Accelerated Stability, mg/100 mL	1.5 max	ASTM D2274
Composition		
Aromatics, mass fraction %	26–31.5	ASTM D5186
Olefins, vol %	Report	ASTM D1319
Saturates, vol %	Report	ASTM D1319
Lubricity, microns	460 max ^A	ASTM D6079 ^A

^A May be altered to be consistent with California Air Resources Board (CARB) or ASTM diesel fuel specifications.

7.3 Coolant:

7.3.1 Coolant, Chevron Delo Extended Life Coolant diluted 50/50

-P/N 227811 50/50 pre-mixed

-P/N 227808 concentrated

7.3.2 The EGR coolant is not specified and is at the discretion of the lab.

7.4 Cleaning Materials:

7.4.1 For cleaning engine parts, use only mineral spirits (solvent) meeting the requirements in Specification D235, Type II, Class C for Aromatic Content (0 % to 2 % by volume), Flash Point (142 °C, min) and Color (not darker than +25 on Saybolt Scale or 25 on Pt-Co Scale), refer to A6.4. (**Warning**—Combustible. Health hazard.) Obtain a Certificate of Analysis for each batch of solvent from the supplier.

7.4.2 Pentane. (**Warning**—Flammable. Health hazard.)

8. Preparation of Apparatus at Rebuild

8.1 Cleaning of Parts:

8.1.1 *Engine Block*—Thoroughly spray the engine with solvent to remove any oil remaining from the previous test and air-dry. Follow the optional use of an engine parts washer by a solvent wash.

8.1.2 *Rocker Covers and Oil Pan*—Remove all sludge, varnish and oil deposits. Rinse with solvent and air-dry. Follow the optional use of an engine parts washer by a solvent wash.

8.1.3 *Auxiliary Oil System*—Flush all oil lines, galleries and external oil reservoirs with solvent to remove any previous test oil and then air-dry.

8.1.4 *Oil Cooler and Oil Filter*—Flush the oil cooler and filter lines with solvent to remove any previous test oil and then

air-dry. Follow the optional use of an engine parts washer by a solvent wash.

8.1.5 *Cylinder Head*—Clean the cylinder heads using a wire brush to remove deposits and rinse with solvent to remove any sludge and oil and then air-dry. Follow the optional use of an engine parts washer by a solvent wash.

8.1.6 *Intake Manifold*—Clean the intake manifold before each test. Scrub the manifold using a nylon brush and solvent, and then wash the manifold using an engine parts washer.

8.1.7 *EGR Cooler*—Replacing or cleaning of the EGR coolers is at the test laboratory's discretion. An example of a successful cleaning method is available from the Test Monitoring Center (TMC) (Annex A1 explains the function of the TMC).

8.1.8 *EGR Venturi Unit*—Clean the venturi before each test. Spray with solvent and scrub with a nylon brush. Further instruction can be found in the Volvo Service Manual.

8.2 *Valves, Seats, Guides, and Springs:*

8.2.1 Visually inspect valves, seats, and springs for defects or heavy wear and replace if necessary. Replacement of the valves, guides, and seat inserts for each test is recommended, but not required. Refer to the Volvo service manual for cylinder head rebuilding procedure.

8.3 *Cylinder Liner, Piston, and Piston Ring Assembly:*

8.3.1 *Cylinder Liner Fitting*—For proper heat transfer, fit cylinder liners to the block using the procedure outlined in the Volvo Service Manual.⁶

8.3.2 *Piston and Rings*—Cylinder liners, pistons, and rings are provided as a set and shall be used as a set. Examine piston rings for any handling damage. Record the pre-test measurements as detailed in 11.1.

8.4 *Injectors:*

8.4.1 *Injectors*— The electronic unit injectors (EUI) may be changed at any time using the procedure specified in the Volvo Service Manual. Be sure to enter the EUI's calibration code into the Engine Control Module (ECM). The calibration code can be found on the EUI label.

—8.5 *Assembly Instructions:*

8.5.1 *General*—The test parts specified for this test are intended to be used without material or dimensional modification. An exception, for example, is approval of a temporary parts supply problem by the surveillance panel, and noting this approval in the test report. All replacement test engine parts shall be genuine Volvo parts. Assemble all parts as illustrated in the Volvo Service Manual except where otherwise noted. Target all dimensions for the means of the specifications. Use Bulldog Oil for lubricating parts during assembly; see A6.10.

8.5.1.1 *Thermostat*—Replace the thermostat with sleeve 21474103. See Fig. A6.1.

8.5.1.2 *Connecting Rod Bearings*—Install new connecting rod bearings for each test. See 10.1 for recording pre-test measurements.

8.5.1.3 *Main Bearings*—Install new main bearings for each test.

8.5.1.4 *Piston Under-crown Cooling Nozzles*—Particular care shall be taken in assembling the piston under-crown cooling nozzles to insure proper piston cooling (as outlined in the Volvo Service Manual⁶).

NOTE 1—Proper oil pressure is also important to assure sufficient oil volume for proper cooling.

8.5.1.5 *Thrust Washers*—Install new thrust washers for each test.

8.5.2 *New Parts*—Use test parts on a first-in/first-out basis. Install the following new parts for each rebuild; see Table A6.1 for part numbers:

8.5.2.1 Cylinder liners.

8.5.2.2 Pistons.

8.5.2.3 Piston rings.

8.5.2.4 Overhaul gasket set.

8.5.2.5 Oil filters.

8.5.2.6 Engine coolant conditioner.

8.5.2.7 Primary fuel filter.

8.5.2.8 Secondary fuel filter.

8.5.2.9 Valve stem seals.

8.5.2.10 Valve guides.

8.5.2.11 Connecting rod bearings.

8.5.2.12 Main bearings.

8.5.2.13 Thrust washers.

8.5.2.14 Oil Mist Separator Unit

8.6 *Measurements:*

⁶ Volvo Service Manuals are available from local Mack Trucks, Inc. distributors.

8.6.1 *Calibrations*—Calibrate thermocouples, pressure gages, speed, torque and fuel flow measuring equipment prior to each reference oil test or at any time readout data indicates a need. Conduct calibrations with at least two points that bracket the normal operating range. Make these calibrations part of the laboratory record. During calibration, connect leads, hoses and readout systems in the normally used manner and calibrate with necessary standards. For controlled temperatures, immerse thermocouples in calibration baths. Calibrate standards with instruments traceable to the National Institute of Standards and Technology (NIST) on a yearly basis.

8.6.2 *Temperatures:*

8.6.2.1 *General*—Measure temperatures with thermocouples and conventional readout equipment or equivalent. For temperatures in the 0 °C to 150°C range, calibrate temperature measuring systems to ± 0.5 °C for at least two temperatures that bracket the normal operating range. Insert all thermocouples so that the tips are located midstream of the flow unless otherwise indicated.

8.6.2.2 *Ambient Air*—Locate thermocouple in a convenient, well-ventilated position from the engine and hot accessories.

8.6.2.3 *Coolant*—Locate the coolant-out thermocouple in the water elbow flange after the thermostat housing. Locate it in the center of the water stream. Refer to Fig. A5.7. Locate the coolant-in thermocouple near the connection to the engine, as shown in Fig. A5.8.

8.6.2.4 *Oil Gallery*—Locate thermocouple on the left gallery of the engine (intake side), as shown in Fig. A5.9. Insertion depth of 64.2 mm from face of engine block.

8.6.2.5 *Oil Sump Temperature*—Using a front oil pan configuration, locate a thermocouple on the intake side of the oil pan, 158.8 mm from the front of the pan and 254 mm from the top of the pan rail. Insertion depth shall be 76.2 mm to 27mm from the inside wall of the oil pan. Refer to Fig. A5.6 and A5.10.

8.6.2.6 *Inlet Air Temperature*—Locate the inlet air thermocouple in the center of the air stream leading to the turbocharger inlet, with the dimensions shown in Fig. 1 below and pictured in Fig. A5.11. It is not necessary to control inlet air humidity, but measurement is required.

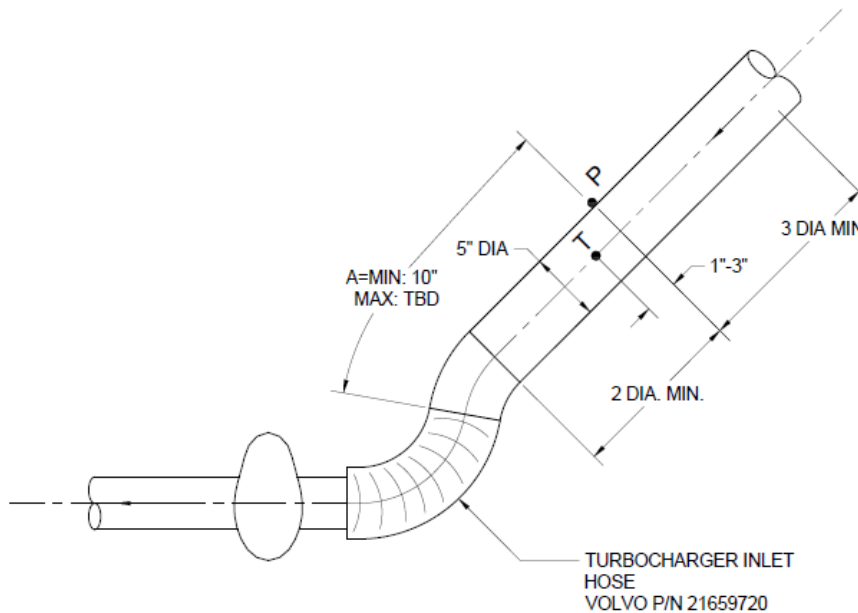

Fig.1 Inlet Air Piping for the Turbocharger

8.6.2.7 *Fuel In*—Locate thermocouple at connection of fuel inlet fitting on the intake side of the engine, as shown in Fig. A5.12.

8.6.2.8 *Exhaust Tailpipe*—Locate a thermocouple in the exhaust pipe downstream of the exhaust back pressure tap and CO₂ probe using the dimensions shown below in Fig 2 and pictured in Fig. A5.13.

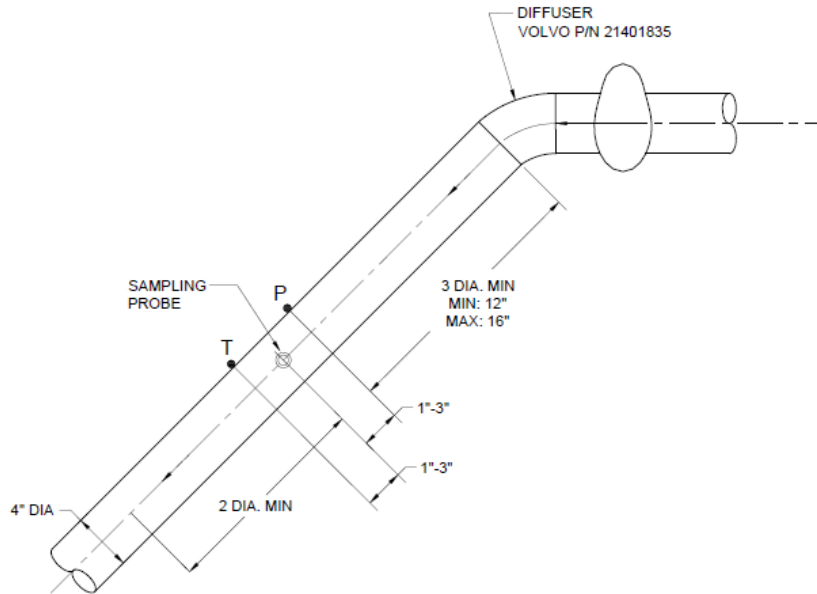

Fig. 2 Exhaust Piping

- 8.6.2.9 *Intake Manifold*—Locate a thermocouple at the tapped fitting on the intake air manifold as shown in [Fig. A5.14](#).
- 8.6.2.10 *EGR Cooler Outlet*—Locate thermocouple as shown in [Fig. A5.15](#).
- 8.6.2.11 *Intercooler Outlet*—Locate the thermocouple downstream of the cooler outlet and prior to the EGR mixer, as shown in [Fig A5.16](#).
- 8.6.2.12 *Oil Jet*—Locate the thermocouple on the oil filter housing, as shown in [Fig A5.17](#). Insertion depths of 78.5 mm from face of oil filter housing.
- 8.6.2.13 *Fuel Gallery*—Locate the thermocouple in the fuel gallery as shown in [Fig A5.18](#). Insertion depth of 50.8 mm from face of cylinder head.
- 8.6.2.14 *Dew point*—Locate the sensor to record the dew point temperature before the air filter, as shown in [Fig A5.19](#).
- 8.6.2.15 *Compressor Discharge*—Locate the thermocouple between the compressor outlet and the intercooler, as shown in [Fig A5.20](#). Locate the thermocouple downstream of the compressor outlet pressure tap.
- 8.6.2.16 *Cylinder Ports*—Locate thermocouples in each cylinder port as shown in [Fig A5.21](#) and [Fig A5.22](#). This measurement is not mandatory, but it is recommended for diagnostic purposes.
- 8.6.2.17 *Oil From Cooler*—Locate the thermocouple on the oil filter housing, as shown in [Fig A5.23](#). Insertion depths of 24.1 mm from face of oil filter housing. This measurement is not mandatory, but it is recommended for diagnostic purposes.
- 8.6.3 *Pressures:*
- 8.6.3.1 *After Oil Filter (Main Oil Gallery)*—Locate the pickup on the left side of the engine (intake side). Refer to [Fig. A5.24](#).
- 8.6.3.2 *Pre-Turbine Exhaust*—Locate the pickup on the exhaust manifold, see [Fig. A5.25](#). This measurement is not mandatory, but it is recommended for diagnostic purposes.
- 8.6.3.3 *Intake Manifold (Air Boost)*—Take the measurement at the tapped fitting provided on the intake manifold as illustrated in [Fig. A5.26](#).
- 8.6.3.4 *Intake Air Pressure (Intake Air Restriction)*—Measure it with a static port (pressure tap hole) located upstream of Inlet Air Temperature (see [Fig. A5.11](#)).
- 8.6.3.5 *Exhaust Back Pressure*—Measure exhaust back pressure in a straight section of pipe upstream of the exhaust tailpipe thermocouple, with a pressure tap hole as shown in [Fig. A5.13](#). Do not locate the tap downstream of either the temperature thermocouple or the CO₂ probe.
- 8.6.3.6 *Crankcase Pressure*—Locate the pickup on the valve cover between cylinder 3 and cylinder 4. Refer to [Fig A5.27](#).
- 8.6.3.7 *Compressor Discharge*—Locate the pickup as shown in [Fig A5.20](#). Locate the pressure tap upstream of the compressor outlet thermocouple.
- 8.6.3.8 *Coolant System*—Locate the pickup at the top of the coolant system expansion tank, as shown in [Fig A5.28](#).
- 8.6.3.9 *Air Cleaner*—Locate pickups to read the pressure differential for both the high and low sides across the air cleaner, as shown in [Fig A5.29](#) and [Fig A5.30](#).
- 8.6.3.10 *Coolant Pump*—Locate the pickup on the right side cover, as shown in [Fig A5.31](#).
- 8.6.3.11 *Intercooler Outlet*—Locate the pickup at the outlet of the intercooler, as shown in [Fig A5.16](#). Locate the pressure tap upstream of the intercooler outlet thermocouple.

8.6.3.12 *Fuel Gallery*—Locate the pickup in the fuel gallery, as shown in Fig A5.32.

8.6.3.13 *Oil Jet*—Locate the pickup on the oil filter housing, as shown in Fig A5.33.

8.6.3.14 *Cylinder Head Oil*—Locate the pickup in the cylinder head, as shown in Fig A5.7.

8.6.4 *Carbon Dioxide Measurements*:

8.6.4.1 *General*—Calibrate the sensors prior to each measurement taken during the course of the test. The CO₂ levels for the calibration span gases are specified. The intake span gas shall be 2 % to 4 % CO₂. The exhaust span gas shall be 10 % to 15 % CO₂. The blend quality for all span gases shall be Primary Standard ± 1 %. The intake and exhaust CO₂ samples shall have a dew point no greater than 5 °C.

8.6.4.2 *Exhaust Carbon Dioxide Probe*—Measure the exhaust CO₂. Locate the probe downstream of the exhaust back-pressure tap. Use a 6.4 mm probe that meets the Code of Federal Regulations, Title 40 Part 86.310-79. The probe diameter is not to exceed the sample line diameter. Refer to Fig. A5.13.

8.6.4.3 *Intake Manifold Carbon Dioxide Probe*—Locate the probe in the intake manifold, as shown in Fig A5.34. Use a 6.4 mm probe that meets the Code of Federal Regulations, Title 40 Part 86.310-79. The probe diameter is not to exceed the sample line diameter. Inset the probe tip 6.3 mm from the face of the cylinder head.

8.6.5 *System Time Responses*—The maximum allowable system time responses are shown in Table 3. Determine system time responses in accordance with the Data Acquisition and Control Automation II (DACA II) Task Force Report.⁷

TABLE 3 Maximum Allowable System Time Responses

Measurement Type	Time Response, s
Speed	2.0
Temperature	3.0
Pressure	3.0
Flow	45.0

9. Procedure

9.1 *Pretest Procedure*:

9.1.1 *Initial Oil Fill for Pretest Break-In*—The initial oil fill is 25.8 kg of test oil. Pressure fill through the location described in 6.2.3.5.

9.1.2 *Pretest Break-In*:

9.1.2.1 Run the break-in sequence described in Annex A8.

9.1.2.2 Drain the oil after the break-in is completed within 1 h and allowed to drain for at least 3 min. Replace all oil filters. Refill the engine with 22.8 kg of test oil and conduct the test in accordance with 9.4.

9.2 *Engine Start-Up*—Perform all engine start-ups in accordance with Annex A8. Start-ups are not included as test time. Test time starts as soon as the engine reaches or returns to the test cycle. Record the first time the engine reaches test cycle conditions as the test clock start on the appropriate form.

9.3 *Engine Shutdown*:

9.3.1 Perform all non-emergency shutdowns in accordance with Annex A8. The shutdown operation does not count as test time. Record the length and reason of each shutdown on the appropriate form.

9.3.2 All operationally valid tests should not exceed 10 shutdowns. Additionally, all operationally valid tests should not exceed downtime of 150 h. Conduct an engineering review if either condition is exceeded.

9.4 *Test Cycle*:

9.4.1 The test cycle includes a 30 min break-in followed by a 360 h test. Non-reference oil tests may run longer than 360 h provided that all posttest measurements required in 10.2 are performed at the extended EOT and the additional EOT h are reported on the appropriate forms. The official test length, EOT date and time reported should correspond to the 360 h date and time. Operating conditions are shown in Table 1.

9.4.2 *Operational Validity*—Determine operational validity in accordance with Annex A7.

9.5 *Oil Samples*—Take 120 mL oil samples according to Table 5. Take the EOT oil sample at start of cool down. Always take oil samples before new oil is added. Obtain oil samples from the pre-filter pressure port, refer to Fig. A5.4. This can be done by installing a tee fitting, a small petcock valve and No. 4 Aeroquip line of length 254 mm to 305 mm, from which the sample is taken. Prior to each sample, take a minimum 140 mL purge. After sample completion, be sure to return the purge to the engine.

9.6 *Oil Addition and Drain*:

9.6.1 Initially establish the full mark as the oil mass after running at test conditions for 4 h. Follow the oil consumption sampling log sheet in Annex A.13.

9.7 *Fuel Samples*—Take one 120 mL fuel sample at SOT and at EOT.

⁷ The Data Acquisition and Control Automation II Task Force Report may be obtained from the ASTM Test Monitoring Center, 6555 Penn Avenue, Pittsburgh, PA 15206-4489, Attention: Administrator.

9.8 Periodic Measurements:

9.8.1 Make measurements at 6 min intervals on the parameters listed in 9.8.2 and record statistics on the appropriate form. Automatic data acquisition is required. Recorded values shall have minimum resolution as shown in Table 4. Characterize the procedure used to calculate the data averages on the appropriate form.

TABLE 4 Minimum Resolution of Recorded Measurements

Parameter	Record Data to Nearest	Parameter	Record Data to Nearest
Speed	1 r/min	Blowby	1 L/min
Fuel Flow	0.1 kg/h	Inlet Air Dew Point	1 °C
Coolant Temperatures	0.1 °C	Oil Temperatures	0.1 °C
Fuel In Temperature	0.1 °C	Exhaust Temperatures	1 °C
Intake Air Temperature	0.1 °C	EGR Temperatures	1 °C
Intake Manifold Temperature	0.1 °C	Oil Pressures	1 kPa
Exhaust Back Pressure	0.1 kPa	Crankcase Pressure	0.1 kPa
Inlet Air Restriction	0.1 kPa	Intake Manifold Pressure	1 kPa
Torque	1 N·m	Intake and Exhaust CO ₂	0.01 %
Power	1 kW	Oil Mass	0.001 kg
Humidity	0.1 g/kg

9.8.2 Parameters:

- 9.8.2.1 Speed, r/min.
- 9.8.2.2 Torque, N·m.
- 9.8.2.3 Oil Gallery Temperature, °C.
- 9.8.2.4 Oil Sump Temperature, °C.
- 9.8.2.5 Coolant Out Temperature, °C.
- 9.8.2.6 Coolant In Temperature, °C.
- 9.8.2.7 Intake Air Temperature, °C.
- 9.8.2.8 Intake Manifold Temperature, °C.
- 9.8.2.9 Intake Manifold Pressure, kPa.
- 9.8.2.10 Fuel Flow, kg/h.
- 9.8.2.11 Fuel Inlet Temperature, °C.
- 9.8.2.12 Tailpipe Exhaust Back Pressure, kPa.
- 9.8.2.13 Before Filter Oil Pressure, kPa.
- 9.8.2.14 Main Gallery Oil Pressure, kPa.
- 9.8.2.15 Crankcase Pressure, kPa.
- 9.8.2.16 Pre-Turbine Exhaust Temperature, Front Manifold, °C.
- 9.8.2.17 Pre-Turbine Exhaust Temperature, Rear Manifold, °C.
- 9.8.2.18 Inlet Air Restriction, kPa.
- 9.8.2.19 Tailpipe Exhaust Temperature, °C.
- 9.8.2.20 Crankcase Blowby, L/min (see 9.9).
- 9.8.2.21 Pre-Turbine Exhaust Pressure, Front Manifold, kPa.
- 9.8.2.22 Pre-Turbine Exhaust Pressure, Rear Manifold, kPa.
- 9.8.2.23 Inlet Air Humidity, g/kg.
- 9.8.2.24 EGR Cooler Outlet Temperature, °C.
- 9.8.2.25 EGR Pre-Venturi Temperature, °C.
- 9.8.2.26 Inlet Air Dew Point, °C.
- 9.8.2.27 Oil Mass, kg.
- 9.8.2.28 Intercooler Outlet Temperature, °C.

9.9 *Blowby*—Record the crankcase blowby on the appropriate form. Take care to prevent oil traps from occurring in the blowby line at any time during operation.

9.10 *Carbon Dioxide*—Measure and record intake and exhaust CO₂ levels every 8 h.

10. Inspection of Engine, Fuel, and Oil

10.1 Pre-Test Measurements:

- 10.1.1 *Pistons*—No piston measurements are required.
- 10.1.2 *Piston Rings*—Clean and measure in accordance with the Mack Test Ring Cleaning and Measuring Procedure,

available from the TMC. Report results on the appropriate form.

10.1.3 *Connecting Rod Bearings:*

10.1.3.1 Prior to measuring, mark bearings with a single digit on the locating tang to identify cylinder location.

10.1.3.2 Clean the bearings with solvent (see 7.4.1). Use a soft brush if necessary. Air-dry the bearings. Rinse in pentane. Do not handle bearings with bare hands. Use gloves or plastic covered tongs.

10.1.3.3 Weigh bearings on a scale capable of a resolution of 1 mg.

10.2 *Post Test Engine Measurements :*

10.2.1 *Pistons*—Before removing pistons, carefully remove carbon from top of cylinder sleeve— *do not remove any metal.*

10.2.2 *Cylinder Liners*—Measure in accordance with Instructions for Measuring Cylinder Liners, available from the TMC. Report the results on the appropriate form.

10.2.3 *Piston Rings*—Clean and measure in accordance with the Mack Test Ring Cleaning and Measuring Procedure, available from the TMC. Report results on the appropriate form.

10.2.4 *Connecting Rod Bearings:*

10.2.4.1 Clean the bearings with solvent (see 7.4.1). Use a soft brush if necessary. Air-dry the bearings. Rinse in pentane. Do not handle bearings with bare hands. Use gloves or plastic covered tongs.

10.2.4.2 Weigh bearings on a scale capable of a resolution of 1 mg.

10.3 *Oil Inspection*—Perform all oil analyses listed in 10.3.1-10.3.6 according to the oil sampling schedule in Table 5. Report all results.

10.3.1 *Viscosity*—Analyze oil samples for viscosity at 40 °C and 100 °C in accordance with Test Method D445.

10.3.2 *Metals*—Determine wear metals content (iron, lead, copper, chromium, aluminum, nickel), additive metals content, silicon and sodium levels in accordance with Test Method D5185. Conduct oil analysis as soon as possible after sampling.

10.3.3 *Base Number*—Determine base number in accordance with Test Method D4739.

10.3.4 *Acid Number*—Determine acid number in accordance with Test Method D664.

10.3.5 *Oxidation*—Determine oxidation using both integrated IR (IR measurement techniques are available from the TMC) and peak height IR.

10.3.6 *Soot* – Conduct soot analysis in accordance with Test Method D5967, Annex A4.

Table 5 Oil Sampling and Analysis Schedule

Method	D5967-A4	D445-3	D445-5	D664-1	D4739	E168 FTIR T12 IR		E168 FTIR T12 Nitr	D3524M	D5185	
	Soot Wt.% TGA	Viscosity At 40°C cSt	Viscosity At 100°C cSt	TBN	TAN	IR Oxidation		IR Nitration Peak Height	Fuel Dilution	Wear Metals	Sample Volume
						Integrated	Peak Height				
Hours	5 mL	40 mL		35 mL		10 mL			10 mL	10 mL	120 mL
0	X	X	X	X	X	X	X	X		X	120 mL
24 ^A											120 mL
48	X	X	X	X	X	X	X	X	X	X	120 mL
72 ^A											120 mL
96	X	X	X	X	X	X	X	X		X	120 mL
120	X	X	X	X	X	X	X	X		X	120 mL
144	X	X	X	X	X	X	X	X		X	120 mL
168	X	X	X	X	X	X	X	X		X	120 mL
192	X	X	X	X	X	X	X	X		X	120 mL
216	X	X	X	X	X	X	X	X		X	120 mL
240	X	X	X	X	X	X	X	X		X	120 mL
252		X	X			X	X	X		X	120 mL
264	X	X	X	X	X	X	X	X		X	120 mL
276		X	X			X	X	X		X	120 mL
288	X	X	X	X	X	X	X	X		X	120 mL
300		X	X			X	X	X		X	120 mL
312	X	X	X	X	X	X	X	X		X	120 mL
324		X	X			X	X	X		X	120 mL
336	X	X	X	X	X	X	X	X		X	120 mL
348		X	X			X	X	X		X	120 mL
360	X	X	X	X	X	X	X	X	X	X	120 mL

^A 120 mL samples at 24 h and 72 h may be analyzed at the discretion of the lab.

10.4 Fuel Inspections:

10.4.1 Use fuel purchase inspection records to ensure conformance to the specifications listed in [Table 2](#) and to complete the appropriate form for the last batch of fuel used during the test. In addition, perform the following inspections on new (0 h) and EOT (360 h) fuel samples:

10.4.1.1 API Gravity at 15.6 °C, Test Method [D287](#) or [D4052](#).

10.4.1.2 Total Sulfur, mg/kg, Test Method [D2622](#) ([D5453](#), [D4294](#) and [D7039](#) can be substituted). Use one 120 mL sample for inspections.

10.5 Oil Consumption Calculation :

10.5.1 Using the oil mass measurements taken at 6 min intervals (see [9.5](#)), determine the oil consumption in g/h by performing linear regression on the data. Do not use the oil consumption data from the first 24 h of the test. For each of the periods from 24 through 240 regress the 24 h period excluding the first hour. Starting at hour 240 and through the end of the test, regress each 12 h period minus the first hour of each period beginning with hour 360. Average together two consecutive 12 h periods to report the 24 h period average oil consumption (as an example 252 and 264, 276 & 288). To calculate the final average oil consumption, average the periods from test hours 25 through 192.

10.5.1.1 Following any shutdowns, oil samples or oil additions exclude from the regression 1 h of oil mass data to account for the stabilizing of the oil scale.

10.5.1.2 If any shutdowns occur during a 24 h period, the result for that 24 h period shall be the weighted average of all the regression slopes that apply to that period. The weighting of a regression slopes is the length of run time associated with it. An example with two shutdowns, one at 109 h and one at 118.5 h is shown in [Table 6](#).

TABLE 6 24 h Period Oil Consumption Sample Calculation

Oil Scale Data	Time Start (hh:mm)	Time Stop (hh:mm)	Run Time	Regression Slope (g/h)
Stabilizing	100:00	101:00	1:00	n/a
Collecting	101:00	109:00	8:00	40.0
Stabilizing	109:00	110:00	1:00	n/a
Collecting	110:00	118:30	8:30	45.0
Stabilizing	118:30	119:30	1:00	n/a
Collecting	119:30	125:00	5:30	48.5
Oil Consumption (100 to 125) h = $\frac{[(8 \times 40.0) + (8.5 \times 45.0) + (5.5 \times 48.5)]}{22}$				
= 44.1 g/h				

10.5.1.3 Report the average oil consumption for the test on the appropriate form.

11. Laboratory and Engine Test Stand Calibration and Non-Reference Oil Test Requirements

11.1 *Calibration Frequency*—To maintain test consistency and severity levels, calibrate the test stand at regular intervals.

11.2 *Calibration Reference Oils:*

11.2.1 The reference oils used to calibrate T-13 test stands have been formulated or selected to represent specific chemical types or performance levels, or both. They can be obtained from the TMC (see Annex A1). The TMC (see Annex A2) assigns reference oils for calibration tests. These oils are supplied under code numbers (blind reference oils).

11.2.2 *Reference Oils Analysis*—Do not submit reference oils to physical or chemical analyses for identification purposes. Identifying the oils by analyses could undermine the confidentiality required to operate an effective blind reference oil system. Therefore, reference oils are supplied with the explicit understanding that they will not be subjected to analyses other than those specified within this procedure unless specifically authorized by the TMC (see Annex A3). In such cases where analyses are authorized, supply written confirmation of the circumstances involved, the data obtained, and the name of the person authorizing the analysis to the TMC.

11.3 *Test Numbering*—Number each T-13 test to identify the test stand number, the test stand run number, engine serial number, and engine hours at the start of the test. The sequential stand run number remains unchanged for reruns of aborted, invalid, or unacceptable calibration tests. However, follow the sequential stand run number by the letter A for the first rerun, B for the second, and so forth.. For example, 58-12A-2H0380-121 defines a test on stand 58 and stand run 12 as a calibration test that was run twice on engine 2H0380 (serial number) with rebuild kit 121. A test number of 58-14-2H0380-300 defines a test on stand 58 and stand run 14 as a non-reference oil test on engine 2H0380 with rebuild kit 300.

11.4 *New Laboratories and New Test Stands:*

11.4.1 A new lab is any lab that has never previously calibrated a test stand under this test method (See Annex A4).

11.4.2 A new stand is a test cell and support hardware which has never previously been calibrated under this test method.

11.4.3 Calibrate a new test stand in accordance with the Lubricant Test Monitoring System (LTMS).⁸

11.5 *Test Stand Calibration:*

11.5.1 *Test Stand Calibration*—Perform a calibration test on a reference oil assigned by the TMC after ten months or ten operationally valid non-reference tests have elapsed since the completion of the last successful calibration test. An unsuccessful calibration test voids any current calibration on the test stand. A non-reference test stand is defined as when the engine has been installed in the test stand with the test oil and it has been cranked with the intent of firing the engine. Report the date the engine was charged with oil as the oil charged date on the appropriate form. The first time the engine is cranked with the intention of firing the engine is to be reported as the engine start date on the appropriate form.

11.5.2 *Test Stand and Engine Combination*—For reference and non-reference tests, any engine may be used in any stand. However, use the engines in the test stands on a first available engine basis (FIFO). In other words, there shall be no attempt on the part of the test laboratory to match a particular test stand and engine combination for any given test.

11.5.3 If non-standard tests are conducted on a calibrated test stand, the TMC may require the test stand to be recalibrated prior to running standard tests.

11.6 *Test Results:*

11.6.1 The specified measurements for reference oil tests are IR oxidation peak height in absorbance (cm) and percent increase in viscosity at 40 °C from 300 h to 360 h in percent.

11.6.2 *IR Oxidation Peak Height* – Measure the EOT IR oxidation peak height in accordance with section 10.3.5 and

⁸ The Lubricant Test Monitoring System may be obtained from the ASTM Test Monitoring Center, 6555 Penn Avenue, Pittsburgh, PA 15206-4489, Attention: Administrator.

report in on the appropriate form.

11.6.3 *Percent Increase in Viscosity at 40 °C from 300 h to 360 h* – Calculate the percent increase in viscosity at 40 °C according to equation 1 by measuring the viscosity at 40 °C and test hours 300 and 360 respectively in accordance with section 10.3.1. Report the percent change on the appropriate form.

$$KV40PC = \frac{KV40_{360} - KV40_{300}}{KV40_{300} \times 100} \quad (1)$$

11.7 *Reference and Non-Reference Oil Test Requirements:*

11.7.2 Determine calibration acceptance in accordance with the Lubricant Test Monitoring System (LTMS)⁸ as administered by the TMC.

11.8 *Non-Reference Oil Test Result Severity Adjustments*—This test method incorporates the use of a Severity Adjustment (SA) for non-reference oil test results. A control chart technique, described in the LTMS, has been selected for identifying when a bias becomes significant for IR oxidation peak height and percent increase in viscosity at 40 °C from 300 h to 360 h. When calibration test results identify a significant bias, determine a SA in accordance with LTMS. Report the SA value on the appropriate form, Test Results Summary, in the space for SA. Add this SA value to non-reference oil test results, and enter the adjusted result in the appropriate space. The SA remains in effect until a new SA is determined from subsequent calibration test results, or the test results indicate the bias is no longer significant. Calculate and apply SA's on a laboratory basis.

11.9 *Donated Reference Oil Test Programs*—The surveillance panel is charged with maintaining effective reference oil test severity and precision monitoring. During times of new parts introductions, new or re-blended reference oil additions, and procedural revisions, it may be necessary to evaluate the possible effects on severity and precision levels. The surveillance panel may choose to conduct a program of donated reference oil tests in those laboratories participating in the monitoring system, in order to quantify the effect of a particular change on severity and precision. Typically, the surveillance panel requests its panel members to volunteer enough reference oil test results to create a robust data set. Broad laboratory participation is needed to provide a representative sampling of the industry. To ensure the quality of the data obtained, donated tests are conducted on calibrated test stands. The surveillance panel shall arrange an appropriate number of donated tests and ensure completion of the test program in a timely manner.

11.10 *Adjustments to Reference Oil Calibration Periods:*

11.10.1 *Procedural Deviations*—On occasions when a laboratory becomes aware of a significant deviation from the test method, such as might arise during an in-house review or a TMC inspection, the laboratory and the TMC shall agree on an appropriate course of action to remedy the deviation. This action may include the shortening of existing reference oil calibration periods.

11.10.2 *Parts and Fuel Shortages*—Under special circumstances, such as industry-wide parts or fuel shortages, the surveillance panel may direct the TMC to extend the time intervals between reference oil tests. These extensions shall not exceed one regular calibration period.

11.10.3 *Reference Oil Test Data Flow*—To ensure continuous severity and precision monitoring, calibration tests are conducted periodically throughout the year. There may be occasions when laboratories conduct a large portion of calibration tests in a short period of time. This could result in an unacceptably large time frame when very few calibration tests are conducted. The TMC can shorten or extend calibration periods as needed to provide a consistent flow of reference oil test data. Adjustments to calibration periods are made such that laboratories incur no net loss or gain in calibration status.

11.10.4 *Special Use of the Reference Oil Calibration System*—The surveillance panel has the option to use the reference oil system to evaluate changes that have potential impact on test severity and precision. This option is only taken when a program of donated tests is not feasible. The surveillance panel and the TMC shall develop a detailed plan for the test program. This plan requires all reference oil tests in the program to be completed as close to the same time as possible, so that no laboratory or stand, or both calibration is left in an excessively long pending status. In order to maintain the integrity of the reference oil monitoring system, each reference oil test is conducted so as to be interpretable for stand calibration. To facilitate the required test scheduling, the surveillance panel may direct the TMC to lengthen and shorten reference oil calibration periods within laboratories such that the laboratories incur no net loss or gain in calibration status.

12. Report

12.1 For reference oil results, use the standardized report form set available from the ASTM TMC and data dictionary for reporting test results and for summarizing operational data.

NOTE 2—Report the non-reference oil test results on these same forms if the results are intended to be submitted as

candidate oil results against a specification.

12.1.1 Fill out the report forms according to the formats shown in the data dictionary.

12.1.2 Transmit results to the TMC within 5 working days of test completion.

12.1.3 Transmit the results electronically as described in the ASTM Data Communications Committee Test Report Transmission Model (Section 2 — Flat File Transmission Format) available from the ASTM TMC. Upload files via the TMC's website.

12.2 Report all reference oil test results, whether aborted, invalidated, or successfully completed, to the TMC.

12.3 Deviations from Test Operational Limits—Report all deviations from specified test operational limits.

12.4 Precision of Reported Units—Use the Practice E29 rounding-off method for critical pass/fail test result data. Report the data to the same precision as indicated in data dictionary.

12.5 In the space provided, note the time, date, test hour, and duration of any shutdown or off-test condition. Document the outcome of all prior reference oil tests from the current calibration sequence that were operationally or statistically invalid.

12.6 If a calibration period is extended beyond the normal calibration period length, make a note in the comment section and attach a written confirmation of the granted extension from the TMC to the test report. List the outcomes of previous runs that may need to be considered as part of the extension in the comment section.

13. Precision and Bias

13.1 Precision:

13.1.1 Test precision is established on the basis of operationally valid reference oil test results monitored by the TMC (See Annex A4).

13.1.1.1 *Intermediate Precision Conditions*—Conditions where test results are obtained with the same test method using the same test oil, with changing conditions such as operators, measuring equipment, test stands, test engines, and time.

NOTE 3—The Intermediate precision is the appropriate term for this method, rather than repeatability, which defines more rigorous within-laboratory conditions.

13.1.1.2 *Intermediate Precision Limit (i.p.)*—The difference between two results obtained under intermediate precision conditions that would, in the long run, in the normal and correct conduct of the test method, exceed the values shown in **Table 7** in only one case in twenty. When only a single test result is available, the Intermediate Precision Limit can be used to calculate a range (test result \pm Intermediate Precision Limit) outside of which a second test result would be expected to fall about one time in twenty.

TABLE 7 Test Precision

Measured Units		
Test Result	Intermediate Precision, (i.p.)	Reproducibility, (R)
IR oxidation peak height, absorbance/cm	1.3	1.6
Percent increase in viscosity at 40°C from 300 to 360 hours, %	22.8	24.9

13.1.1.3 *Reproducibility Conditions* —Conditions where test results are obtained with the same test method using the same test oil in different laboratories with different operators using different equipment.

13.1.1.4 *Reproducibility Limit (R)*—The difference between two results obtained under reproducibility conditions that would, in the long run, in the normal and correct conduct of the test method, exceed the values shown in **Table 7** in only one case in twenty. When only a single test result is available, the Reproducibility Limit can be used to calculate a range (test result \pm Reproducibility Limit) outside of which a second test result would be expected to fall about one time in twenty.

13.1.2 Test precision, as of May 27, 2015 is shown in **Table 7**.

13.1.3 The TMC updates precision data as it becomes available.

13.2 *Bias*—Bias is determined by applying an accepted statistical technique to reference oil test results and when a significant bias is determined, a severity adjustment is permitted for non-reference oil test results (see **11.8**).

14. Keywords

14.1 cylinder liner wear; diesel engine oil; exhaust gas recirculation; lead; lubricants; oil consumption; oxidation; soot; top ring mass loss; ultra-low sulfur diesel fuel; viscosity increase

ANNEXES
(Mandatory Information)

A.1 ASTM TEST MONITORING CENTER ORGANIZATION

A1.1 Nature and Functions of the ASTM Test Monitoring Center (TMC)—The TMC is a non-profit organization located in Pittsburgh, Pennsylvania and is staffed to: administer engineering studies; conduct laboratory inspections; perform statistical analyses of reference oil test data; blend, store, and ship reference oils; and provide the associated administrative functions to maintain the referencing calibration program for various lubricant tests as directed by TMC Subcommittee D02.B0 and the ASTM Executive Committee. The TMC coordinates its activities with the test sponsors, the test developers, the surveillance panels, and the testing laboratories. Contact TMC through the TMC Director at:

ASTM Test Monitoring Center
6555 Penn Avenue
Pittsburgh, PA 15206-4489
www.astmtmc.cmu.edu

A1.2 Rules of Operation of the ASTM TMC—The TMC operates in accordance with the ASTM Charter, the ASTM Bylaws, the Regulations Governing ASTM Technical Committees, the Bylaws Governing ASTM Committee D02, and the Rules and Regulations Governing the ASTM Test Monitoring System.

A1.3 Management of the ASTM TMC—The management of the Test Monitoring System is vested in the Executive Committee elected by Subcommittee D02.B0. The Executive Committee selects the TMC Director who is responsible for directing the activities of the TMC.

A1.4 Operating Income of the ASTM TMC—The TMC operating income is obtained from fees levied on the reference oils supplied and on the calibration tests conducted. Fee schedules are established by the Executive Committee and reviewed by Subcommittee D02.B0.

A2. ASTM TEST MONITORING CENTER: CALIBRATION PROCEDURES

A2.1 Reference Oils—These oils are formulated or selected to represent specific chemical, or performance levels, or both. They are usually supplied directly to a testing laboratory under code numbers to ensure that the laboratory is not influenced by prior knowledge of acceptable results in assessing test results. The TMC determines the specific reference oil the laboratory shall test.

A2.1.1 Reference Oil Data Reporting – Test laboratories that receive reference oils for stand calibration shall submit data to the TMC on every sample of reference oil they receive. If a shipment contains any missing or damaged samples, the laboratory shall notify the TMC immediately.

A2.2 Calibration Testing:

A2.2.1 Full-scale calibration testing shall be conducted at regular intervals. These full-scale tests are conducted using coded reference oils supplied by the TMC. It is a laboratory's responsibility to keep the on-site reference oil inventory at or above the minimum level specified by the TMC test engineers.

A2.2.2 Test Stands Used for Non-Standard Tests—If a non-standard test is conducted on a previously calibrated test stand, the laboratory shall conduct a reference oil test on that stand to demonstrate that it continues to be calibrated, prior to running standard tests.

A2.3 Reference Oil Storage—Store reference oils under cover in locations where the ambient temperature is between -10 °C and +50 °C.

A2.4 Analysis of Reference Oil—Unless specifically authorized by the TMC, do not analyze TMC reference oils, either physically or chemically. Do not resell ASTM reference oils or supply them to other laboratories without the approval of the TMC. The reference oils are supplied only for the intended purpose of obtaining calibration under the ASTM Test

Monitoring System. Any unauthorized use is strictly forbidden. The testing laboratory tacitly agrees to use the TMC reference oils exclusively in accordance with the TMC's published Policies for Use and Analysis of ASTM Reference Oils, and to run and report the reference oil test results according to TMC guidelines. Additional policies for the use and analysis of ASTM Reference Oils are available from the TMC.

A2.5 Conducting a Reference Oil Test—When laboratory personnel are ready to run a reference calibration test, they shall request an oil code via the TMC website.

A2.6 Reporting Reference Oil Test Results—Upon completion of the reference oil test, the test laboratory transmits the data electronically to the TMC, as described in Section 13. The TMC reviews the data and contacts the laboratory engineer to report the laboratory's calibration status. All reference oil test results, whether aborted, invalidated, or successfully completed, shall be reported to the TMC.

A2.6.1 All deviations from the specified test method shall be reported.

A3. ASTM TEST MONITORING CENTER: MAINTENANCE ACTIVITIES

A3.1 Special Reference Oil Tests—To ensure continuous severity and precision monitoring, calibration tests are conducted periodically throughout the year. Occasionally, the majority or even all of the industry's test stands will conduct calibration tests at roughly the same time. This could result in an unacceptably large time frame when very few calibration tests are conducted.

The TMC can shorten or extend calibration periods as needed to provide a consistent flow of reference oil test data. Adjustments to calibration periods are made such that laboratories incur no net loss or gain in calibration status.

A3.2 Special Use of the Reference Oil Calibration System—The surveillance panel has the option to use the reference oil system to evaluate changes that have potential impact on test severity and precision. This option is only taken when a program of donated tests is not feasible. The surveillance panel and the TMC shall develop a detailed plan for the test program. This plan requires all reference oil tests in the program to be completed as close to the same time as possible, so that no laboratory/stand calibration status is left pending for an excessive length of time. In order to maintain the integrity of the reference oil monitoring system, each reference oil test is conducted so as to be interpretable for stand calibration. To facilitate the required test scheduling, the surveillance panel may direct the TMC to lengthen and shorten reference oil calibration periods within laboratories such that the laboratories incur no net loss or gain in calibration status. To ensure accurate stand, or laboratory, or both severity assessments, conduct non-reference oil tests the same as reference oil tests.

A3.3 Donated Reference Oil Test Programs—The surveillance panel is charged with maintaining effective reference oil test severity and precision monitoring. During times of new parts introductions, new or re-blended reference oil additions, and procedural revisions, it may be necessary to evaluate the possible effects on severity and precision levels. The surveillance panel may choose to conduct a program of donated reference oil tests in those laboratories participating in the monitoring system, in order to quantify the effect of a particular change on severity and precision. Typically, the surveillance panel requests its panel members to volunteer enough reference oil test results to create a robust data set. Broad laboratory participation is needed to provide a representative sampling of the industry. To ensure the quality of the data obtained, donated tests are conducted on calibrated test stands. The surveillance panel shall arrange an appropriate number of donated tests and ensure completion of the test program in a timely manner.

A3.4 Intervals Between Reference Oil Tests—Under special circumstances, such as extended downtime caused by industry-wide parts or fuel shortages, the TMC may extend the intervals between reference oil tests.

A3.5 Introducing New Reference Oils—Reference oils produce various results. When new reference oils are selected, participating laboratories will be requested to conduct their share of tests to enable the TMC to recommend industry test targets. ASTM surveillance panels require a minimum number of tests to establish the industry test targets for new reference oils.

A3.6 TMC Information Letters—Occasionally it is necessary to revise the test method, and notify the test laboratories of the change, prior to consideration of the revision by Subcommittee D02.B0. In such a case, the TMC issues an Information Letter. Information Letters are balloted semi-annually by Subcommittee D02.B0, and subsequently by D02. By this means, the Society due process procedures are applied to these Information Letters.

A3.6.1 *Issuing Authority*—The authority to issue an Information Letter differs according to its nature. In the case of an Information Letter concerning a part number change which does not affect test results, the TMC is authorized to issue such a letter. Long-term studies by the surveillance panel to improve the test procedure through improved operation and hardware control may result in the issuance of an Information Letter. If obvious procedural items affecting test results need immediate attention, the test sponsor and the TMC issue an Information Letter and present the background and data supporting that action to the surveillance panel for approval prior to the semiannual Subcommittee D02.B0 meeting.

A3.7 *TMC Memoranda*—In addition to the Information Letters, supplementary memoranda are issued. These are developed by the TMC and distributed to the appropriate surveillance panel and participating laboratories. They convey such information as batch approvals for test parts or materials, clarification of the test procedure, notes and suggestions of the collection and analysis of special data that the TMC may request, or for any other pertinent matters having no direct effect on the test performance, results, or precision and bias.

A4. ASTM TEST MONITORING CENTER: RELATED INFORMATION

A4.1 *New Laboratories*—Laboratories wishing to become part of the ASTM Test Monitoring System will be requested to conduct reference oil tests to ensure that the laboratory is using the proper testing techniques. Information concerning fees, laboratory inspection, reagents, testing practices, appropriate committee membership, and rater training can be obtained by contacting the TMC Director.

A4.2 *Information Letters: COTCO Approval*—Authority for the issuance of Information Letters was given by the committee on Technical Committee Operations in 1984, as follows: “COTCO recognizes that D02 has a unique and complex situation. The use of Information Letters is approved providing each letter contains a disclaimer to the effect that such has not obtained ASTM consensus. These Information Letters should be moved to such consensus as rapidly as possible.”

A4.3 *Precision Data*—The TMC determines the precision of test methods by analyzing results of calibration tests conducted on reference oils. Precision data are updated regularly. Current precision data can be obtained from the TMC.

A5. SYSTEM SCHEMATICS AND SENSOR LOCATIONS

A5.1 Properly locating the sensor devices is important to this test. The following figures indicate the sensor locations for the T-13 engine components. See Figs. A5.1-A5.35 and Table A5.1.

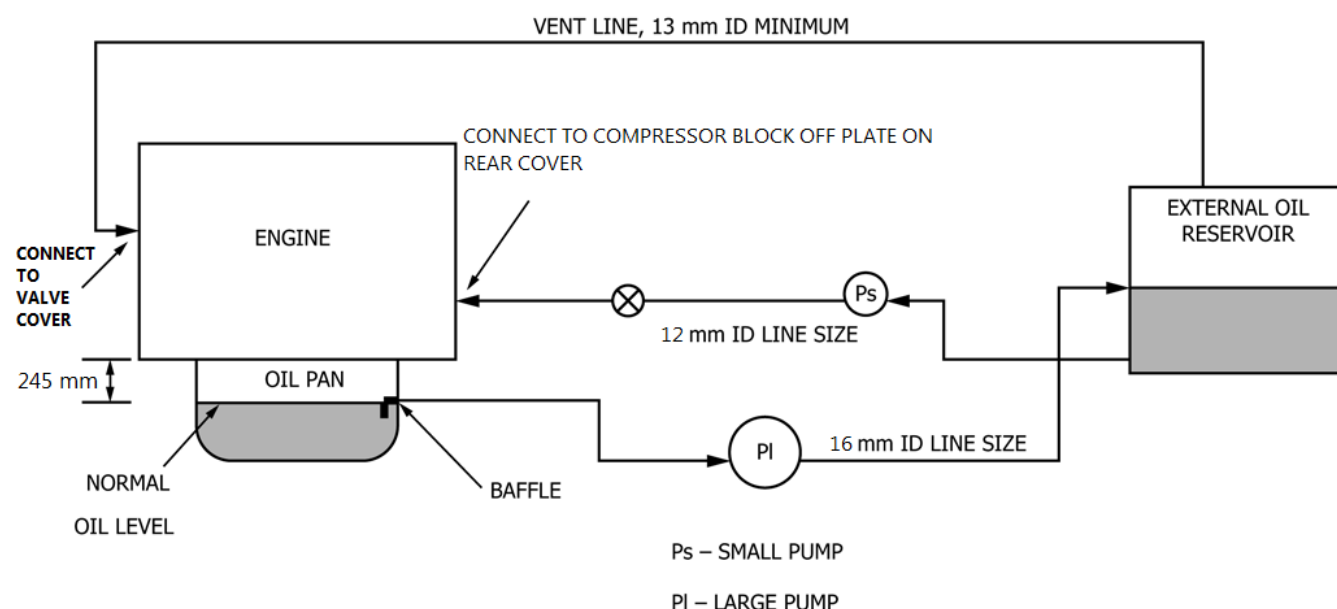

FIG. A5.1 Auxiliary Oil System

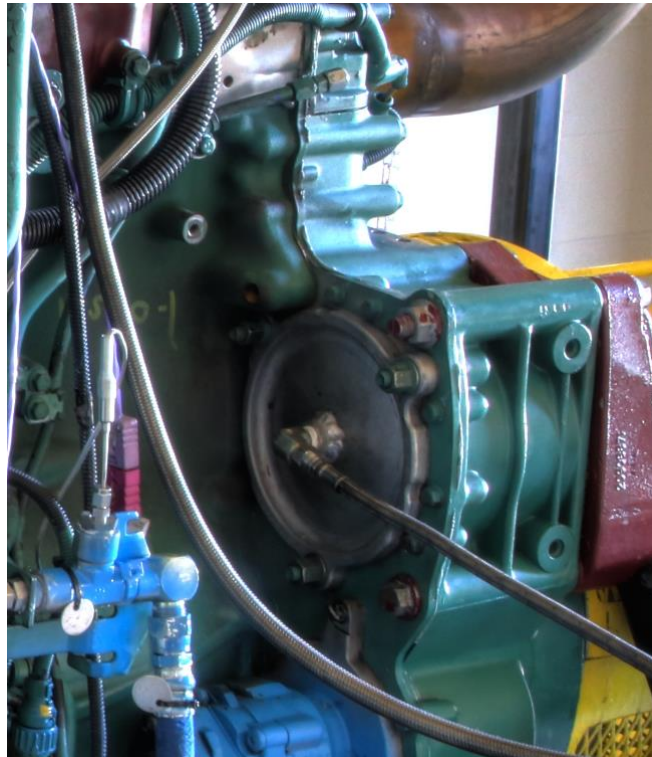
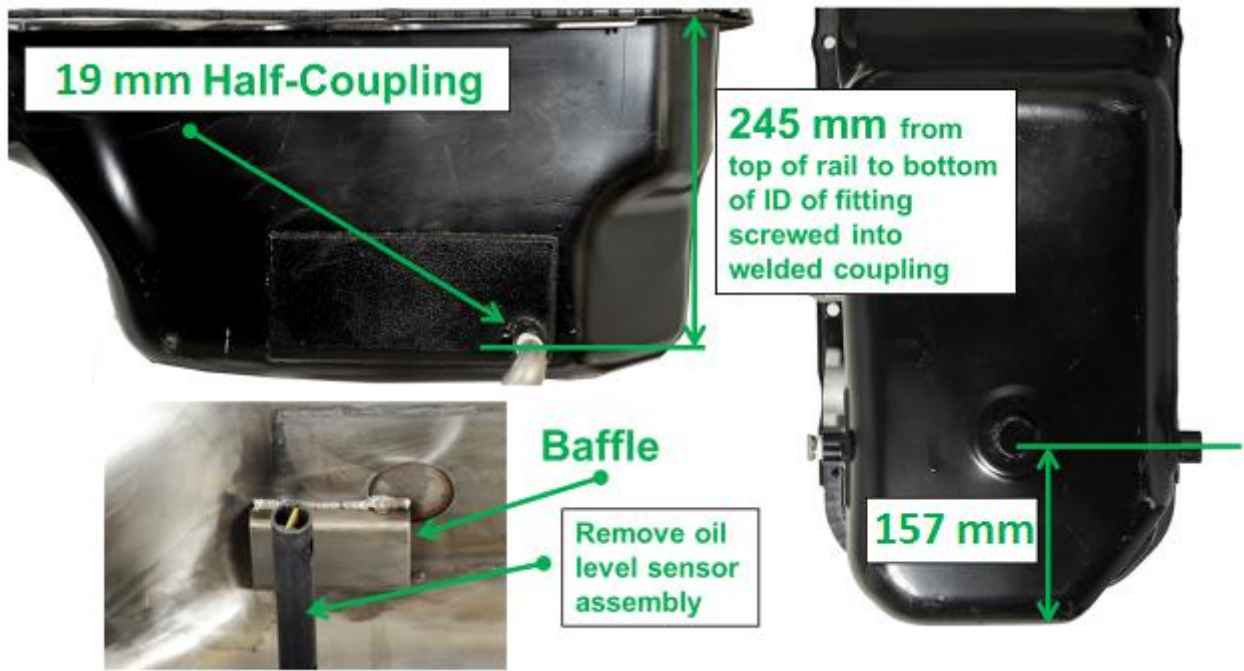

FIG. A5.2 Compressor Block-Off Plate Oil Return Line



A5.3 External Oil System Suction Port

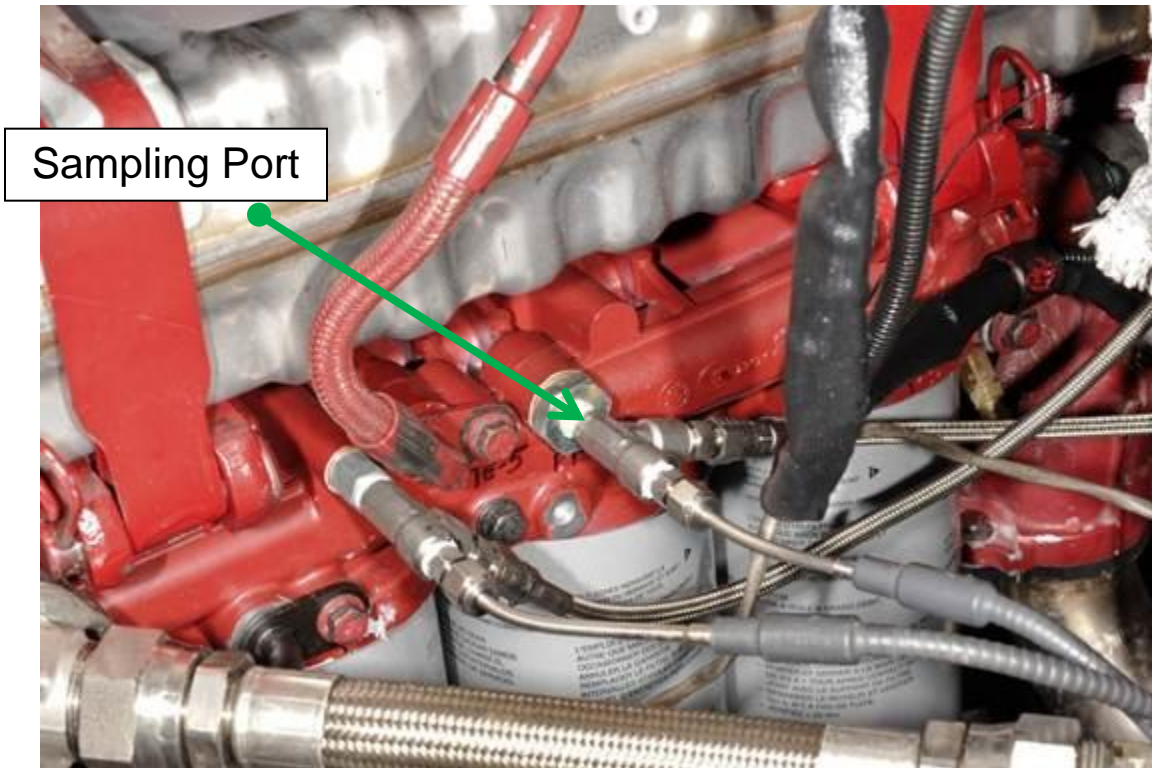

Fig.A5.4 Oil Sampling Port

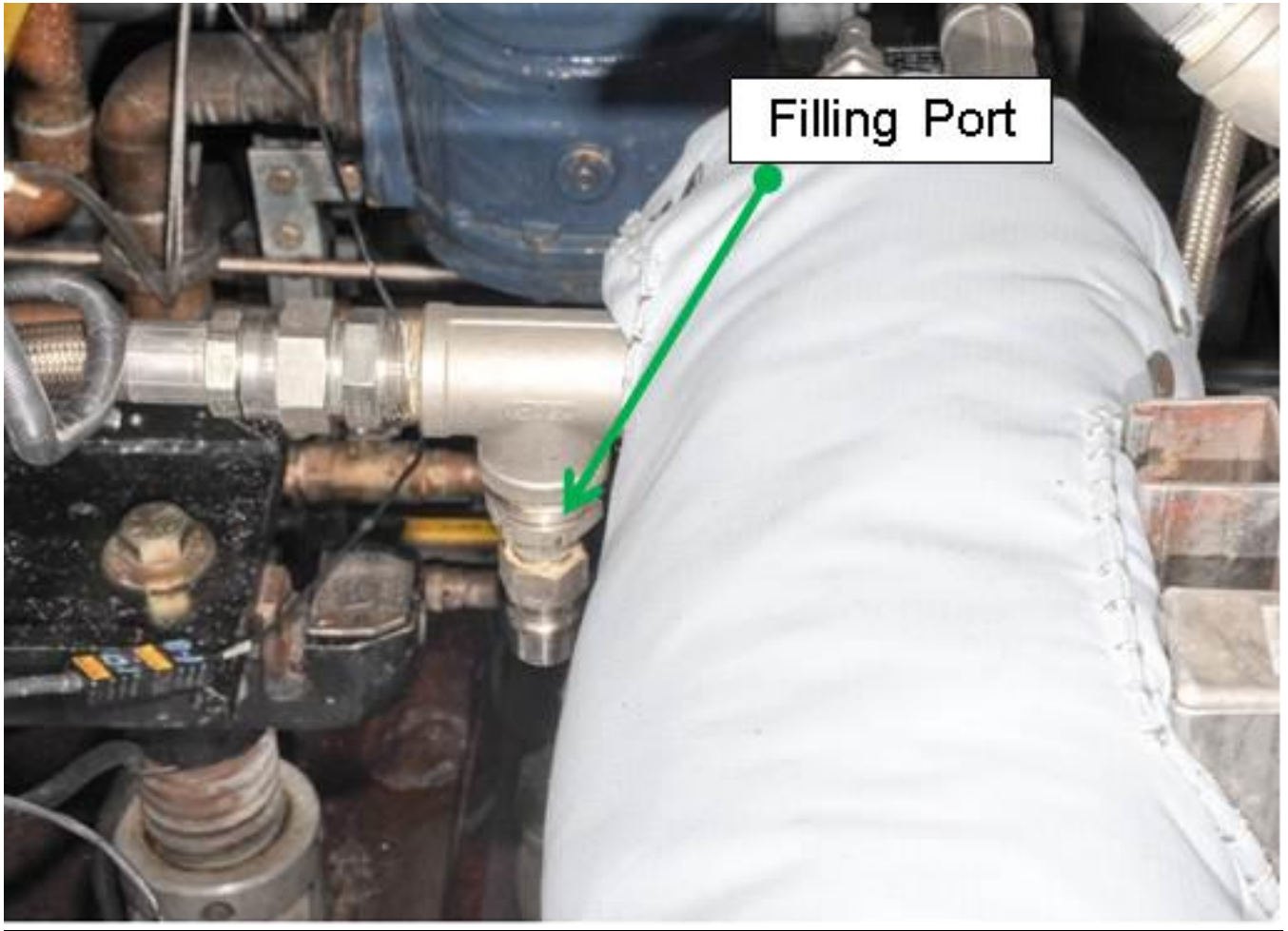

Fig. A5.5 Pressurized Oil Fill Location

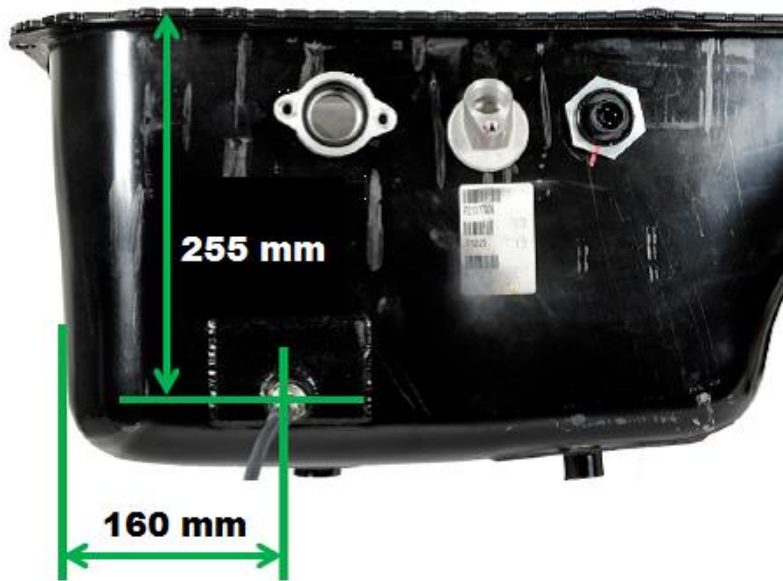

Fig. A5.6 Oil Sump Thermocouple Location

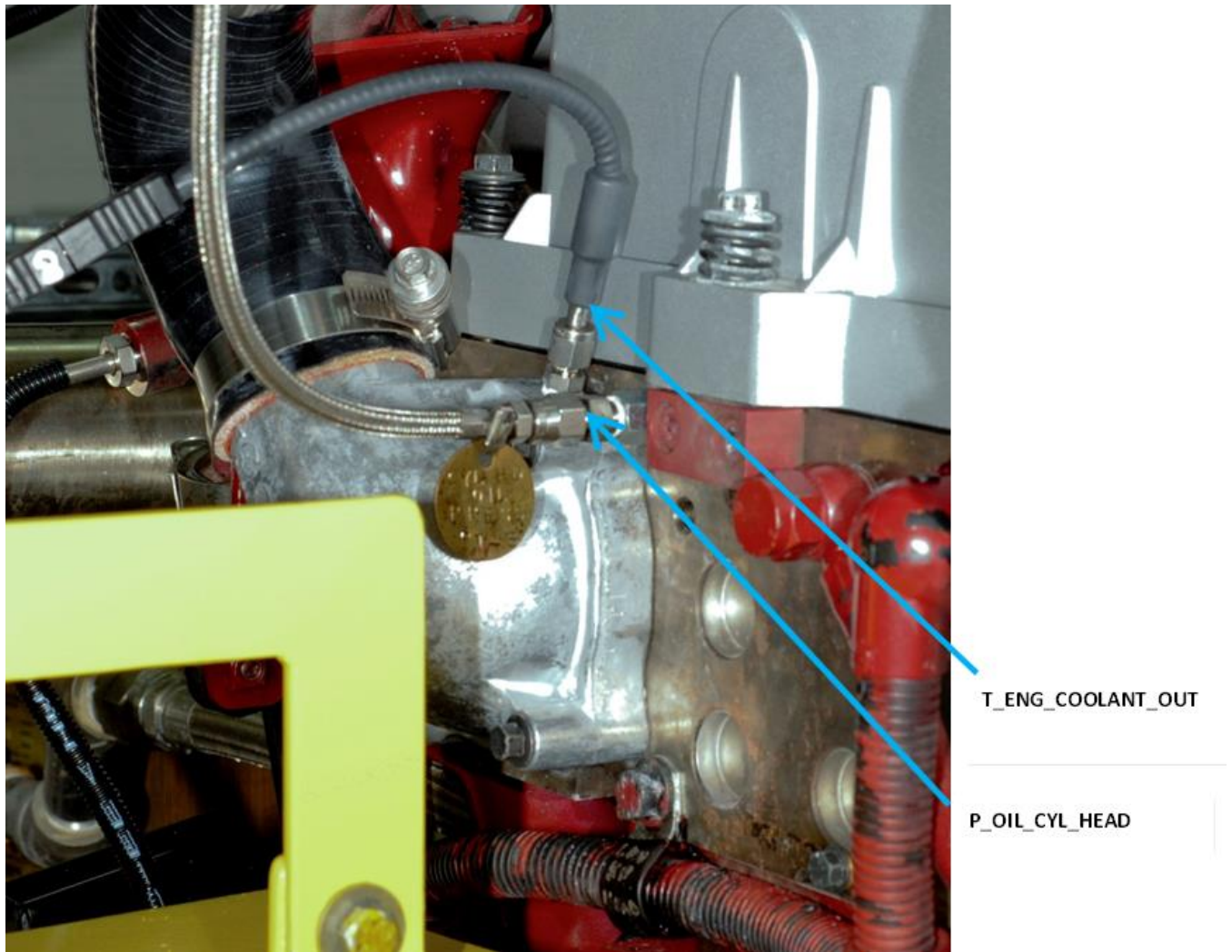
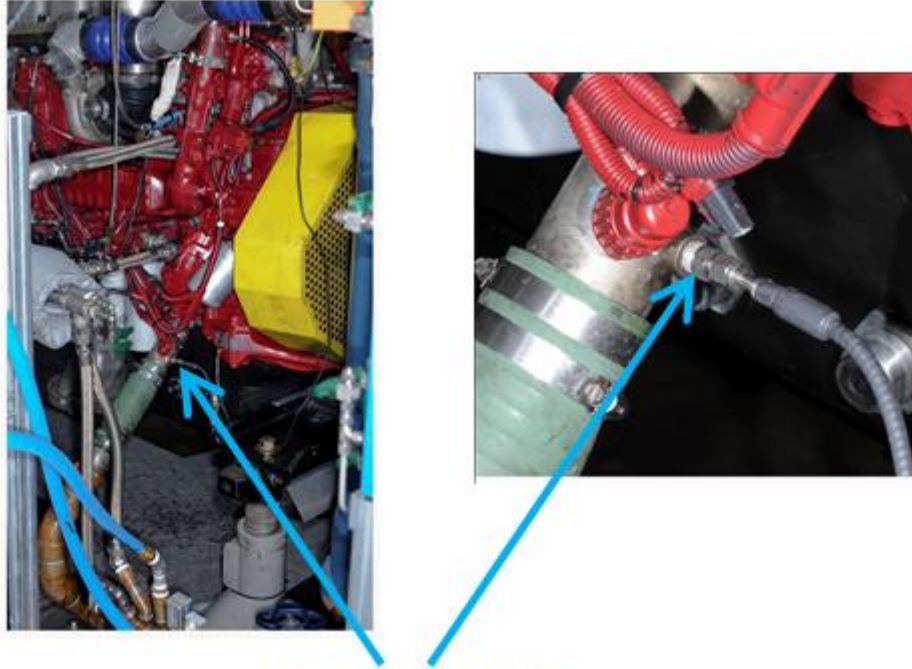
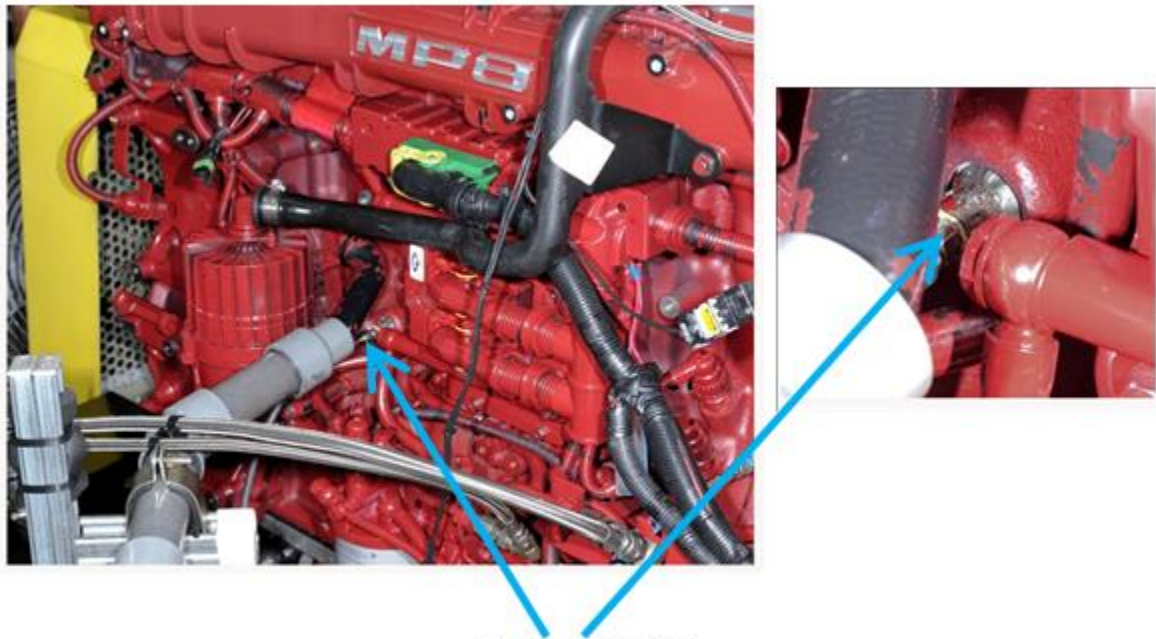

FIG. A5.7 Engine Coolant Out Temperature and Cylinder Head Oil Pressure



T_ENG_COOLANT_IN

FIG. A5.8 Engine Coolant In Temperature



T_OIL_GALLERY

FIG. A5.9 Oil Gallery Temperature

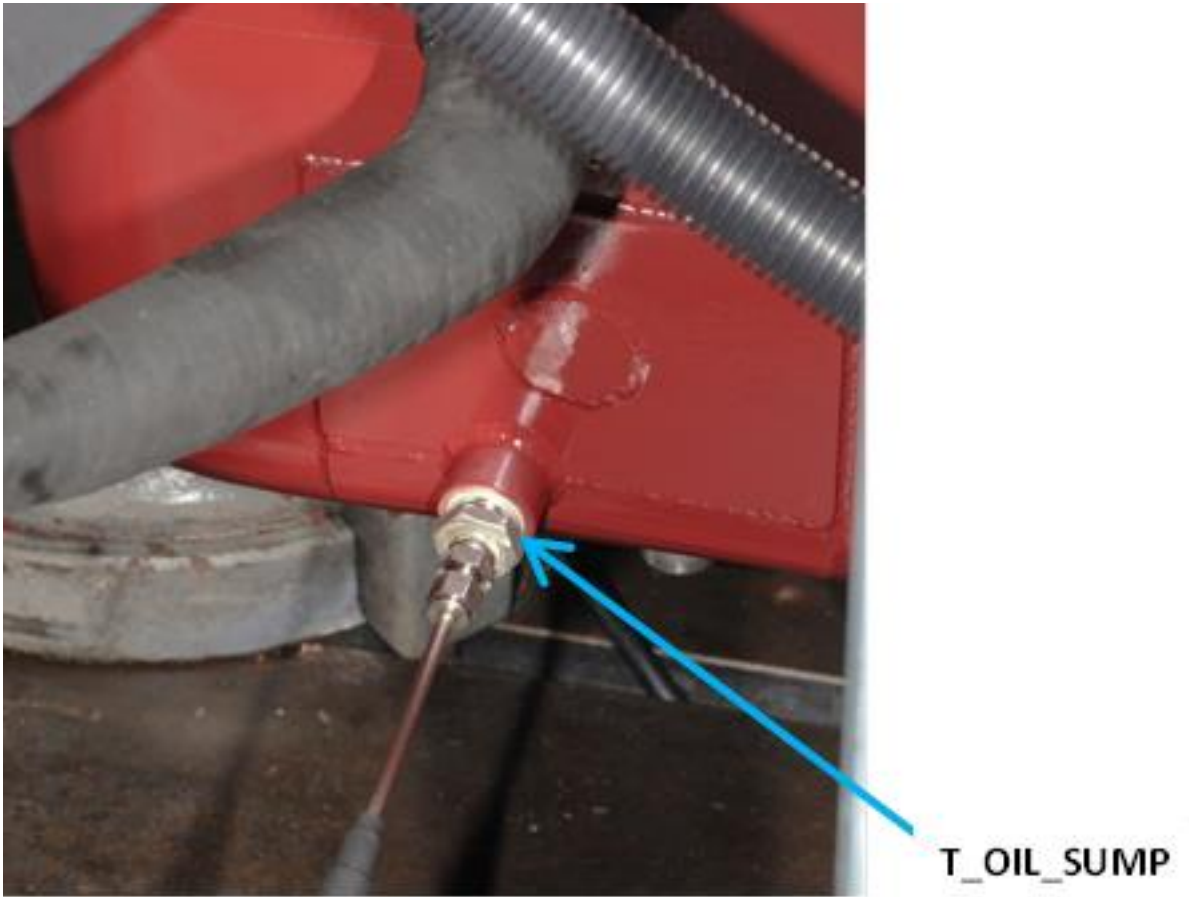

FIG. A5.10 Oil Sump Temperature

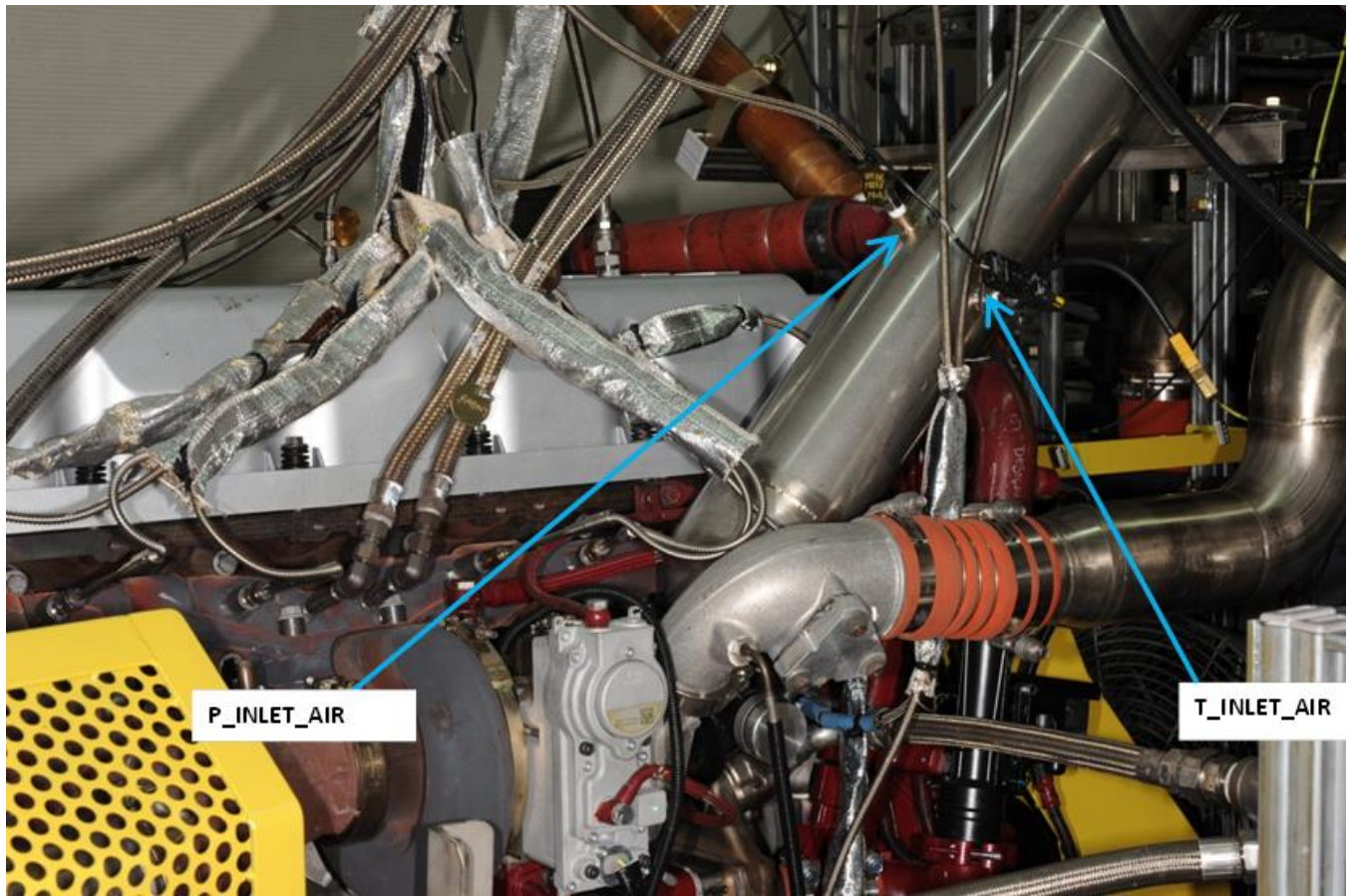

FIG. A5.11 Intake Air Temperature and Pressure

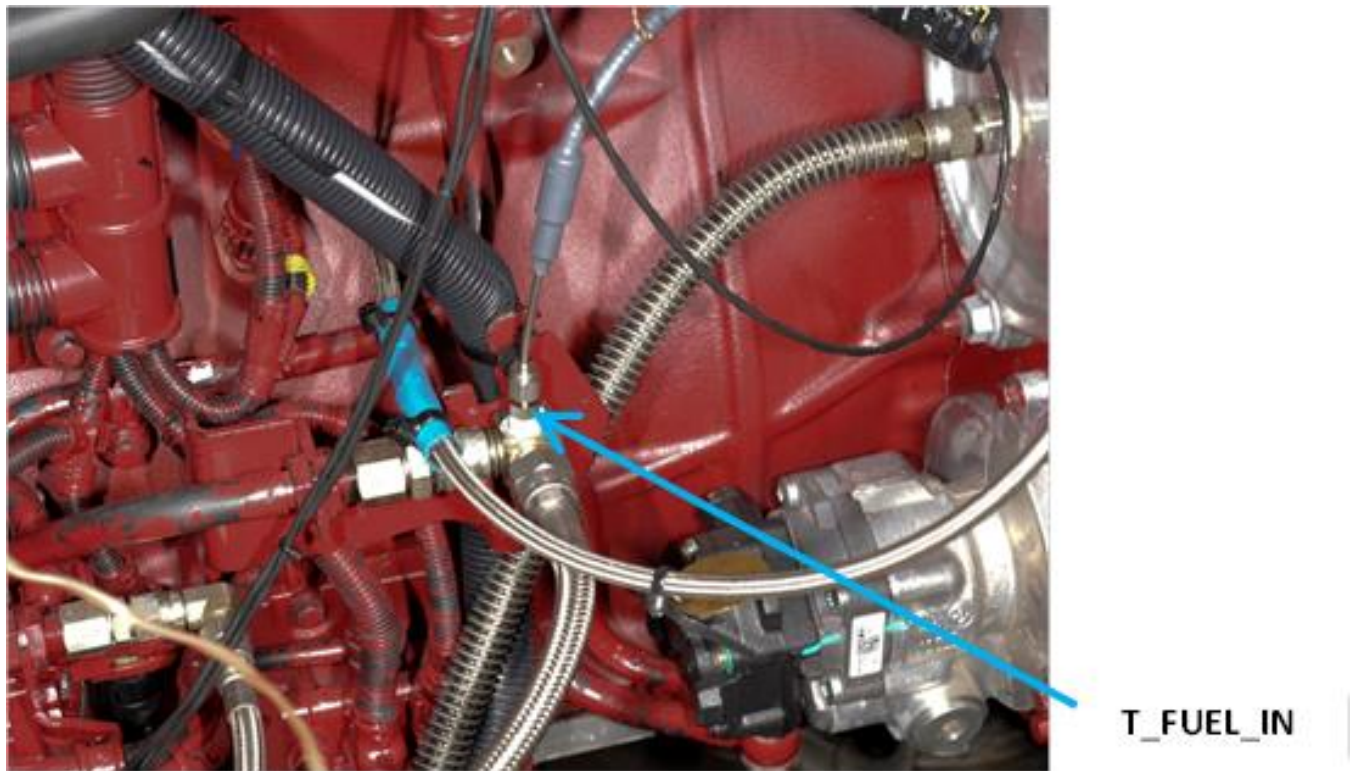

FIG. A5.12 Fuel In Temperature

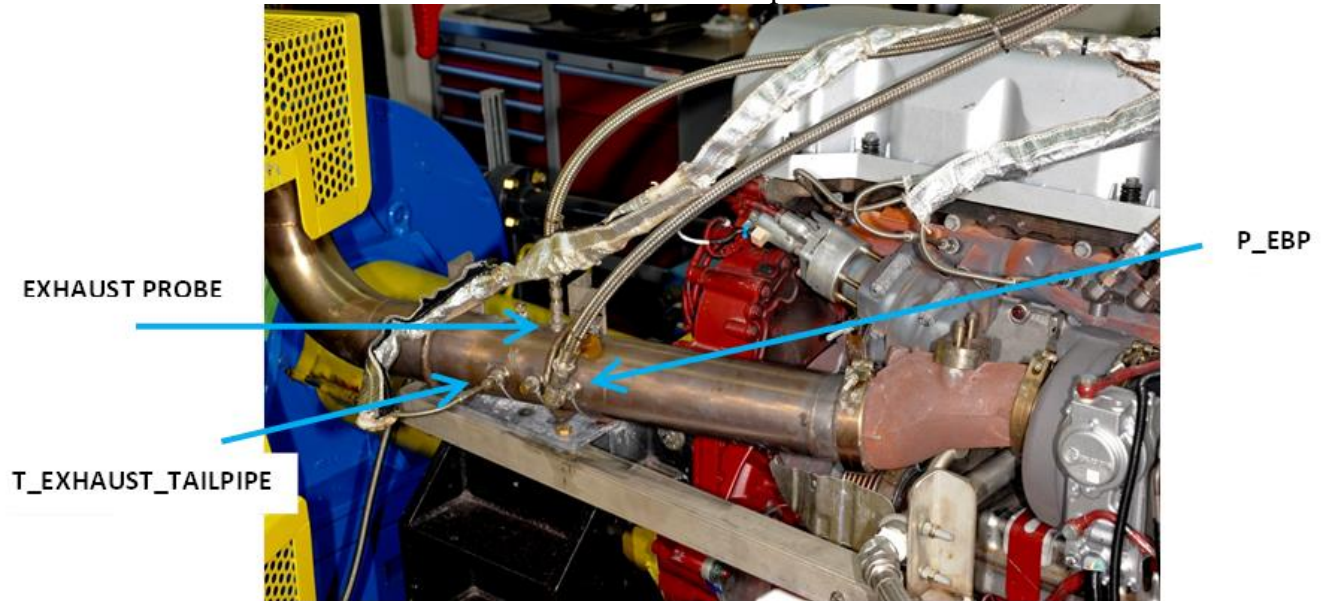

FIG. A5.13 Exhaust Tailpipe Temperature, Exhaust Back-Pressure and Exhaust probe

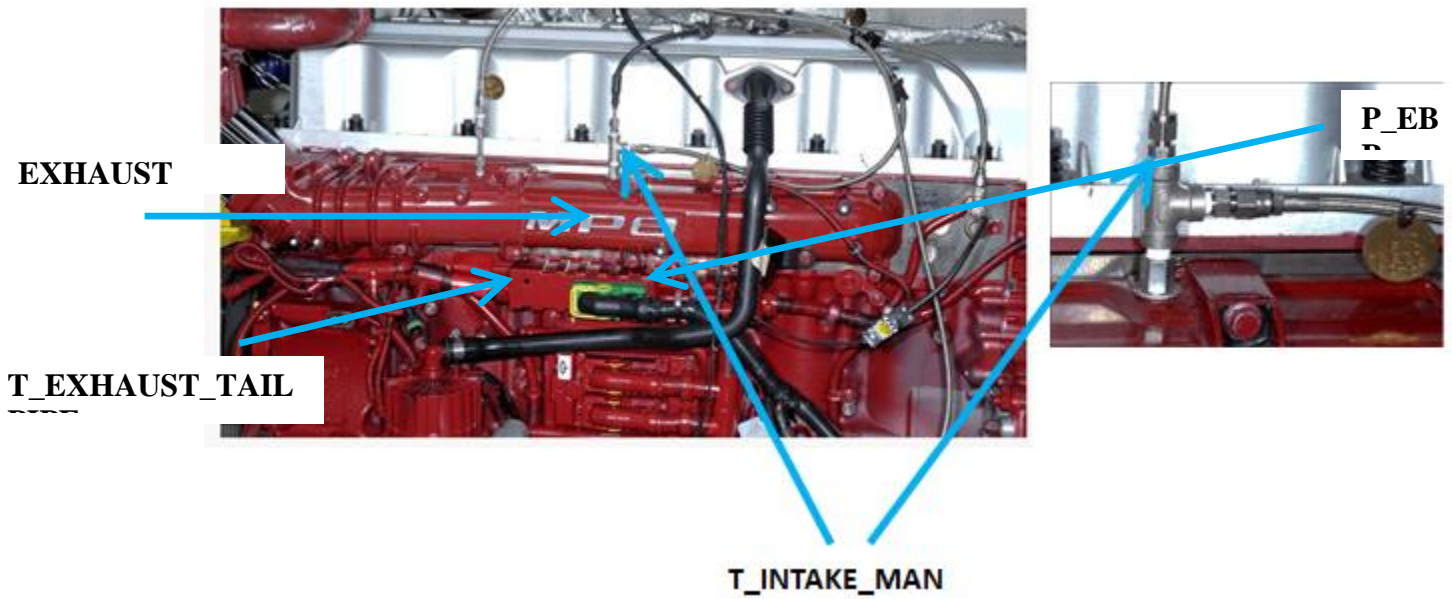

FIG. A5.14 Intake Manifold Temperature



T_EGR_OUT

FIG. A5.15 EGR Gas Out Temperature

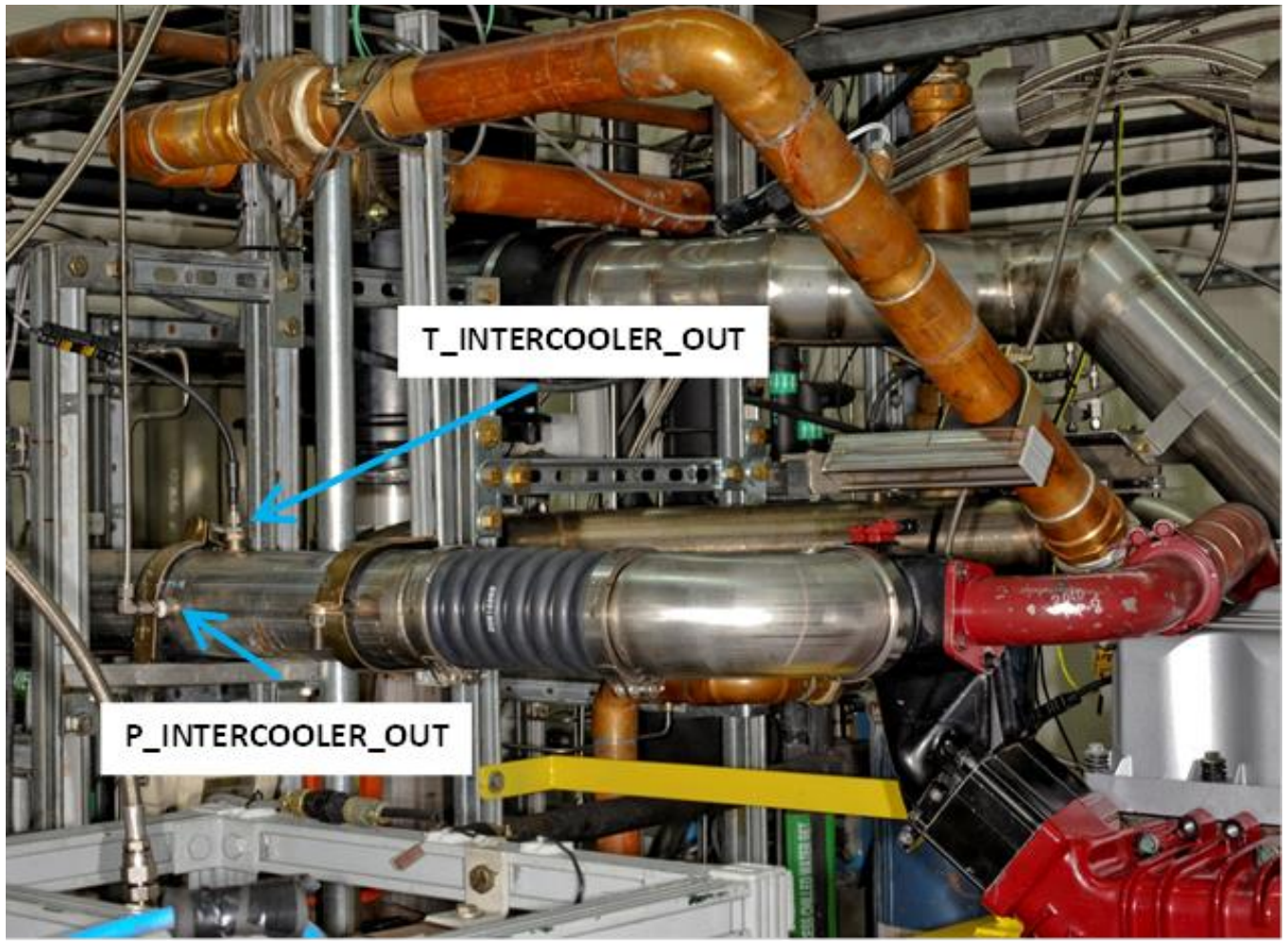

FIG. A5.16 Intercooler Outlet Temperature and Pressure

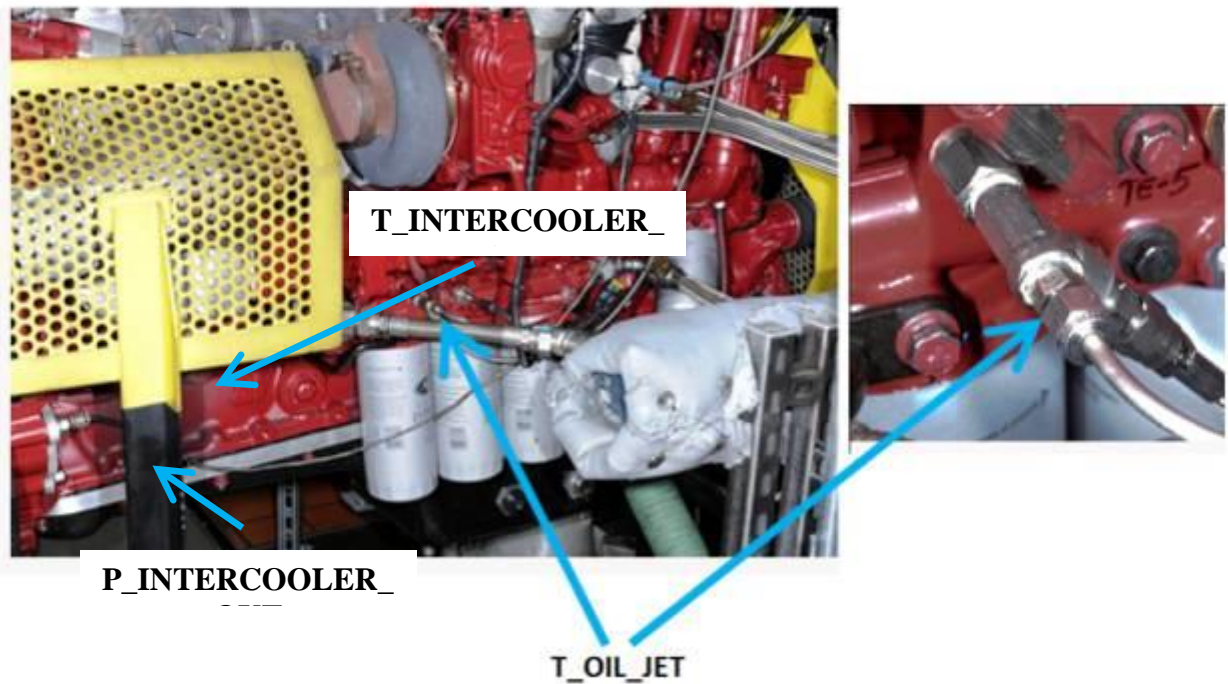
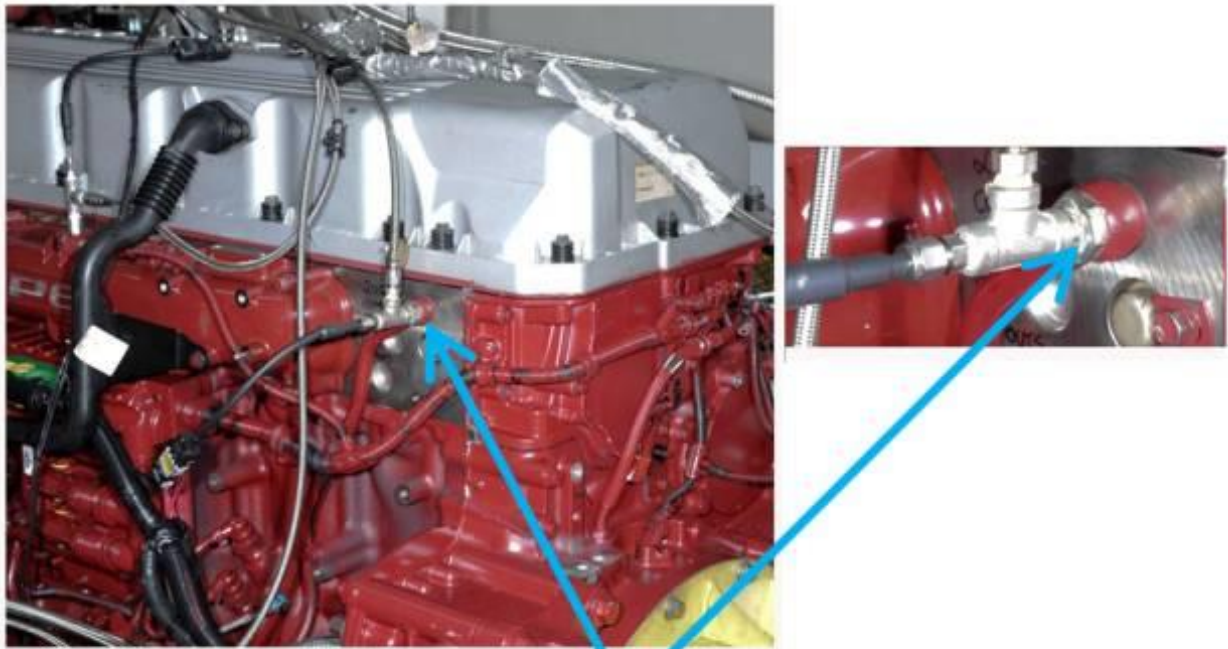

FIG. A5.17 Oil Jet Temperature



T_FUEL_GALLERY

FIG. A5.18 Fuel Gallery Temperature



T_DEWPOINT

FIG. A5.19 Dew point Temperature

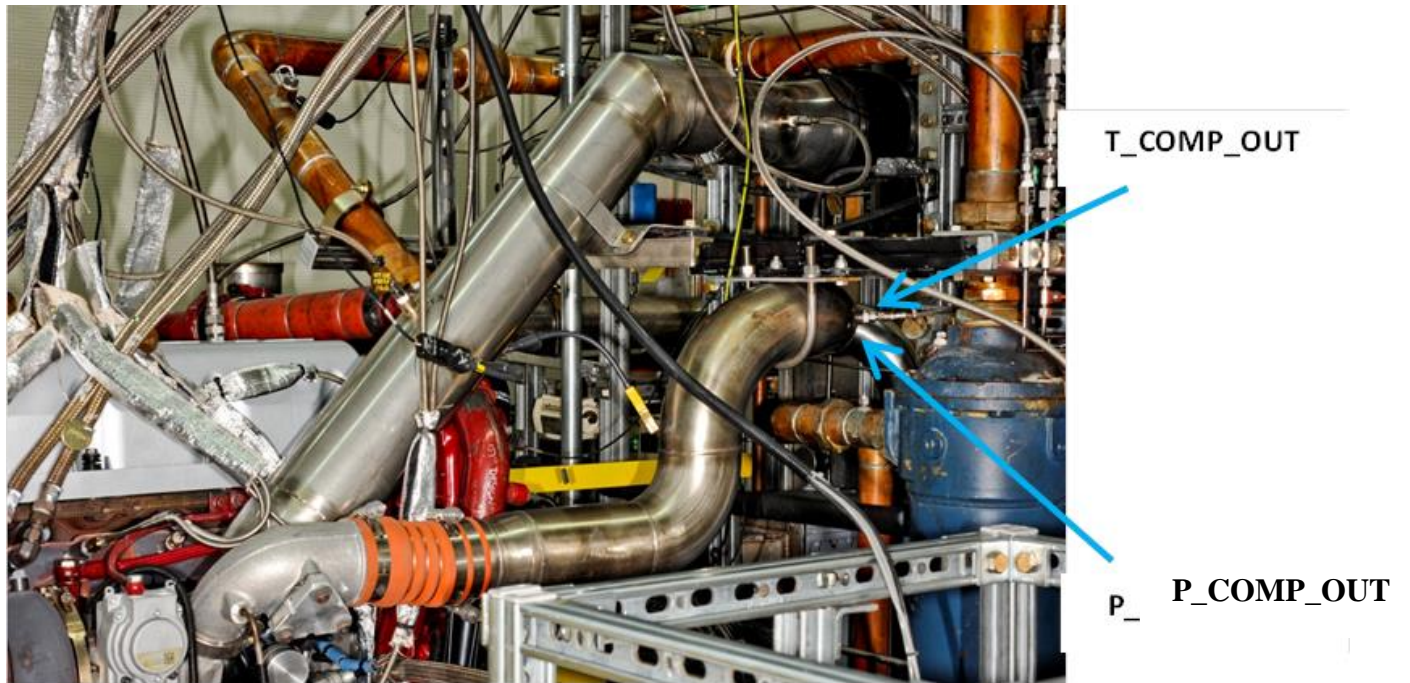

FIG A5.20 Compressor Outlet Temperature and Pressure

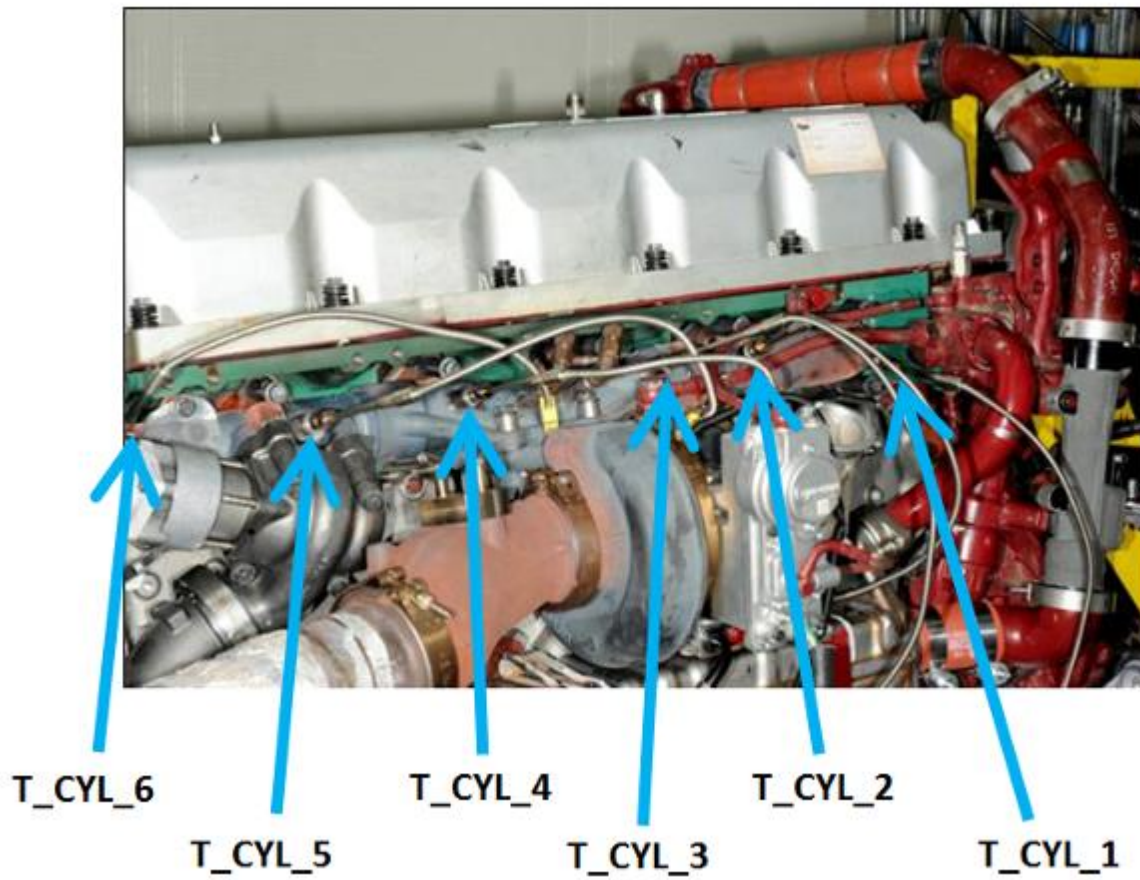

FIG A5.21 Cylinder Port Temperatures

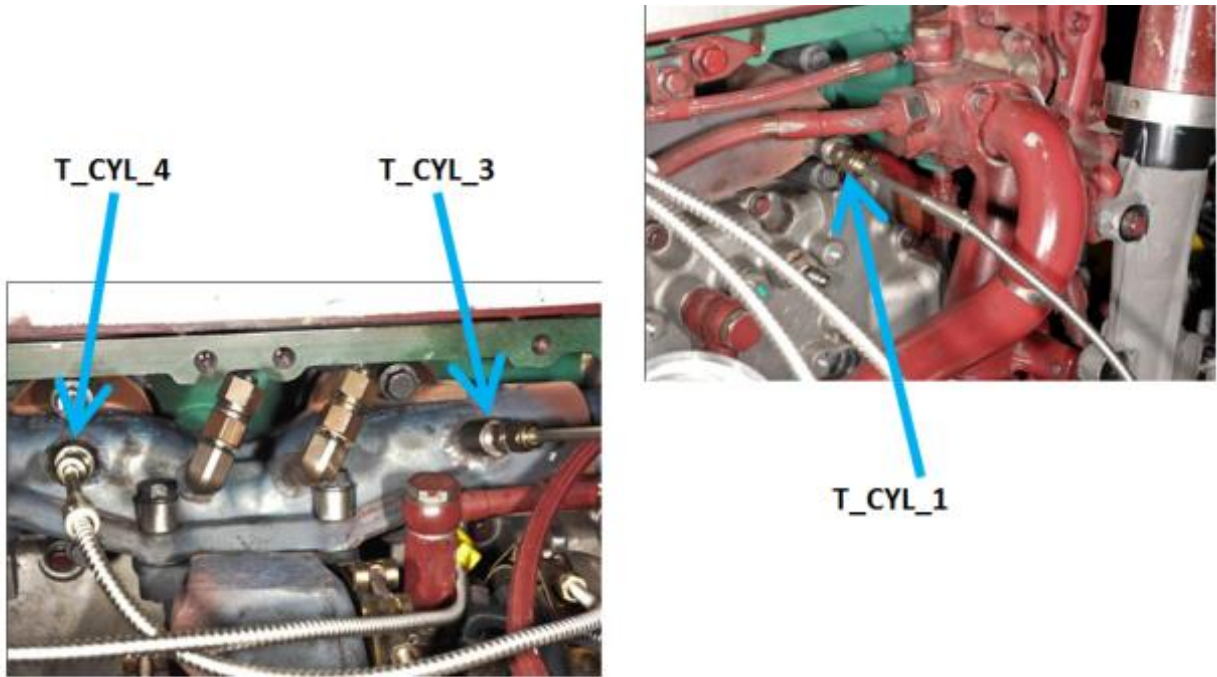

FIG A5.22 Cylinder Port Temperatures (Close View)

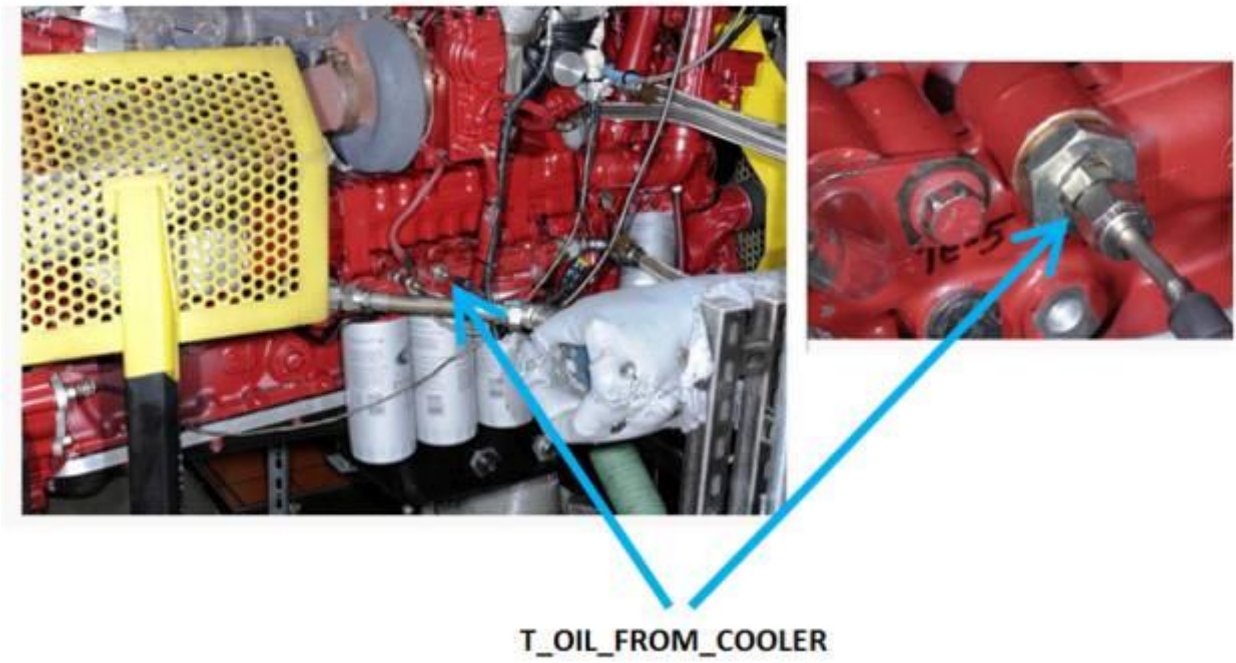
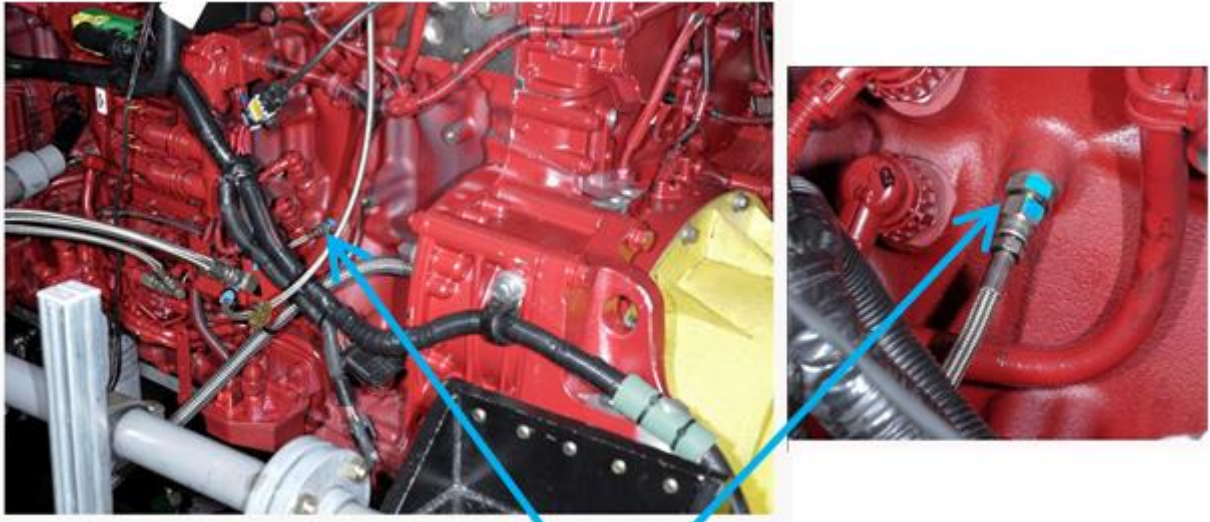
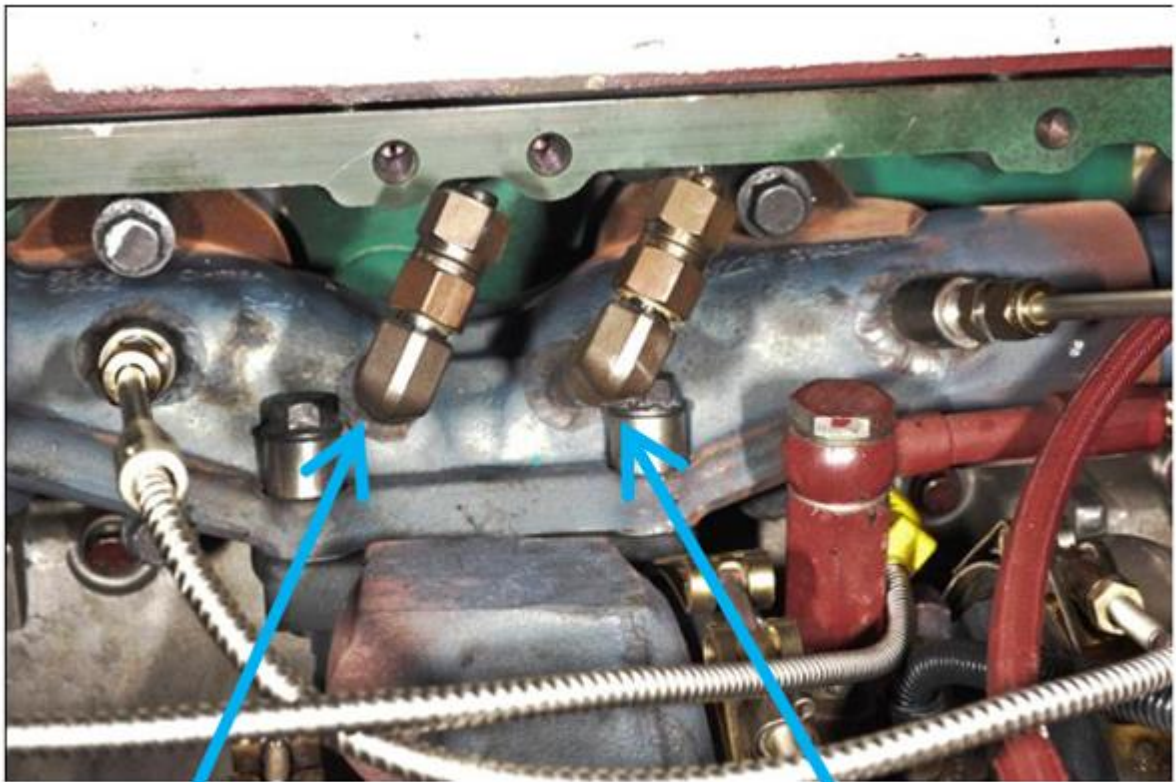

FIG A5.23 Oil Temperature From Cooler



P_OIL_GALLERY

FIG A5.24 Oil Gallery Pressure



**P_R_EXH_MAN
(Rear)**

**P_F_EXH_MAN
(Front)**

FIG A5.25 Exhaust Manifold Pressures

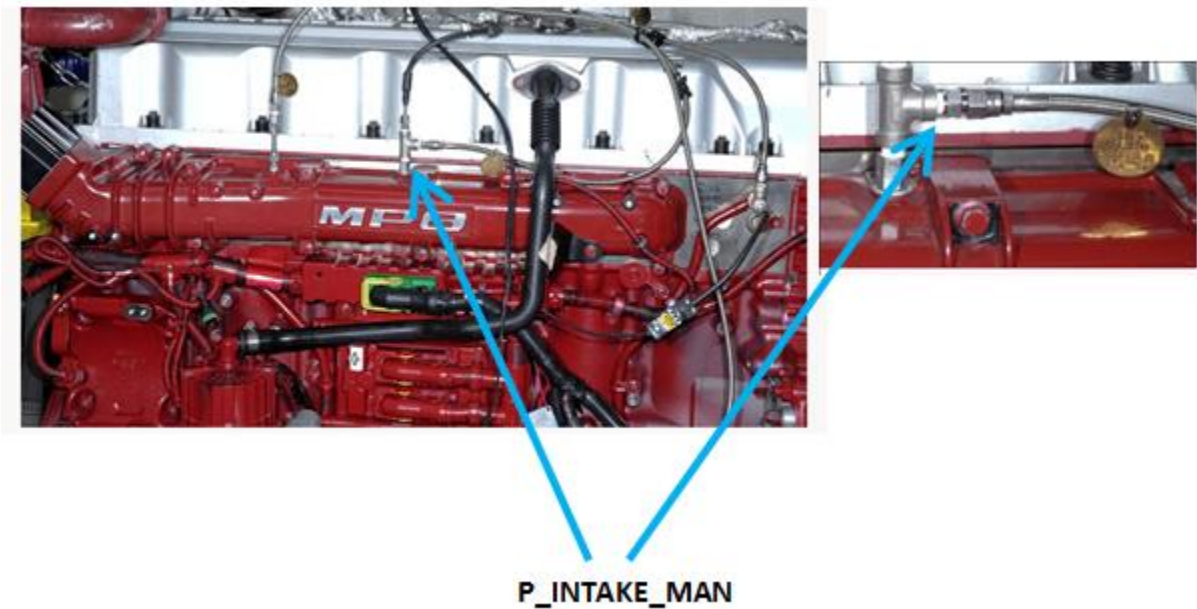

FIG A5.26 Intake Manifold Pressure

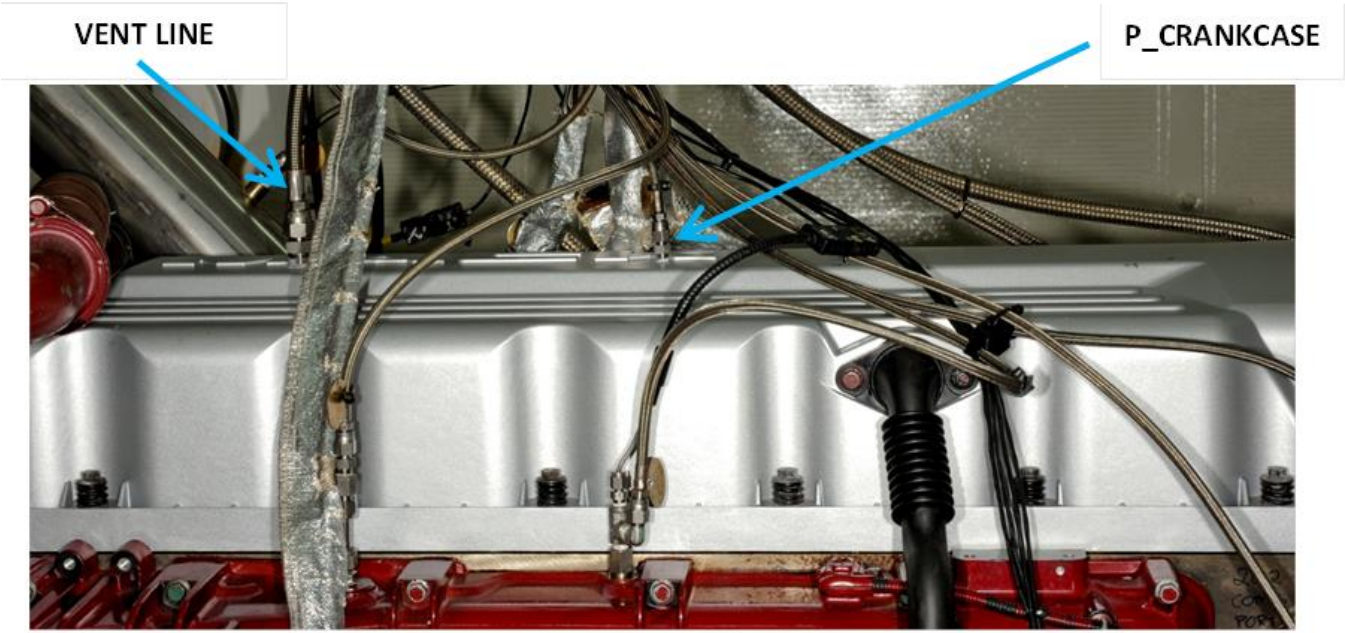
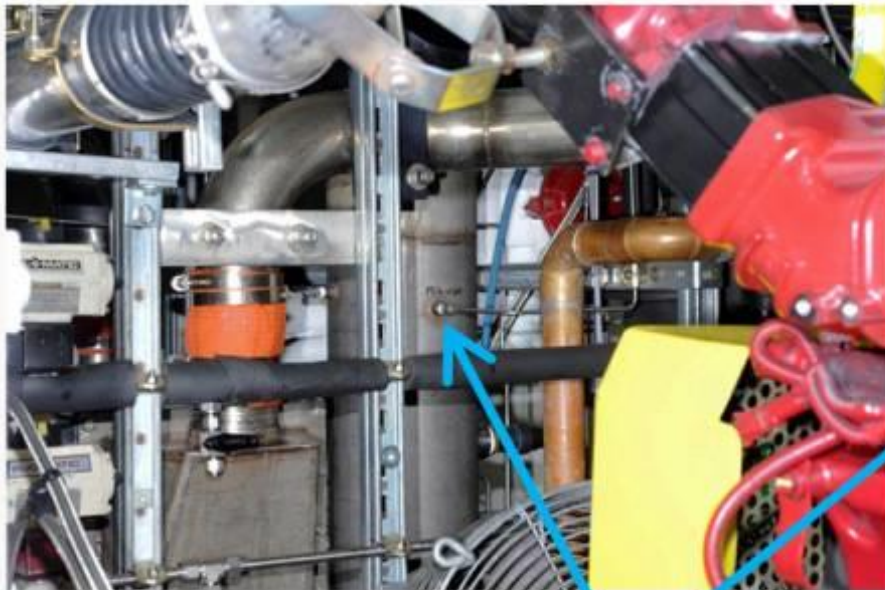

FIG A5.27 Crankcase Pressure and Vent of External Oil Vessel



P_COOL_TANK

FIG A5.28 Coolant Expansion Tank Pressure



**P_AIR_CLEANER
(High Side)**

FIG A5.29 Air Cleaner Pressure Differential (High Side)

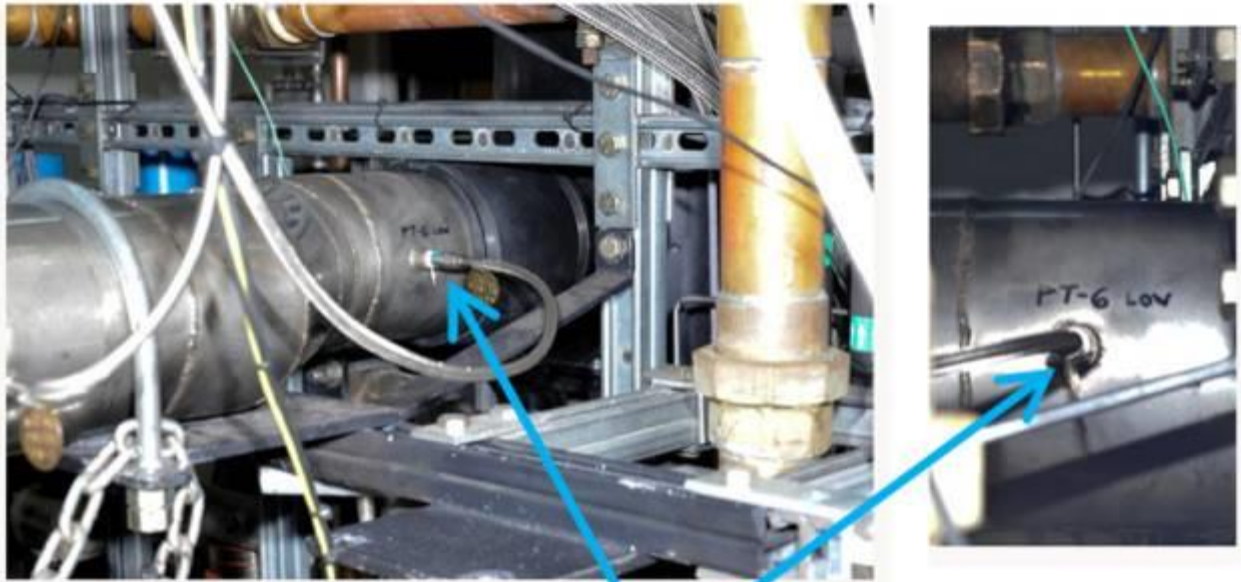

**P_AIR_CLEANER
(Low Side)**

FIG A5.30 Air Cleaner Pressure Differential (Low Side)

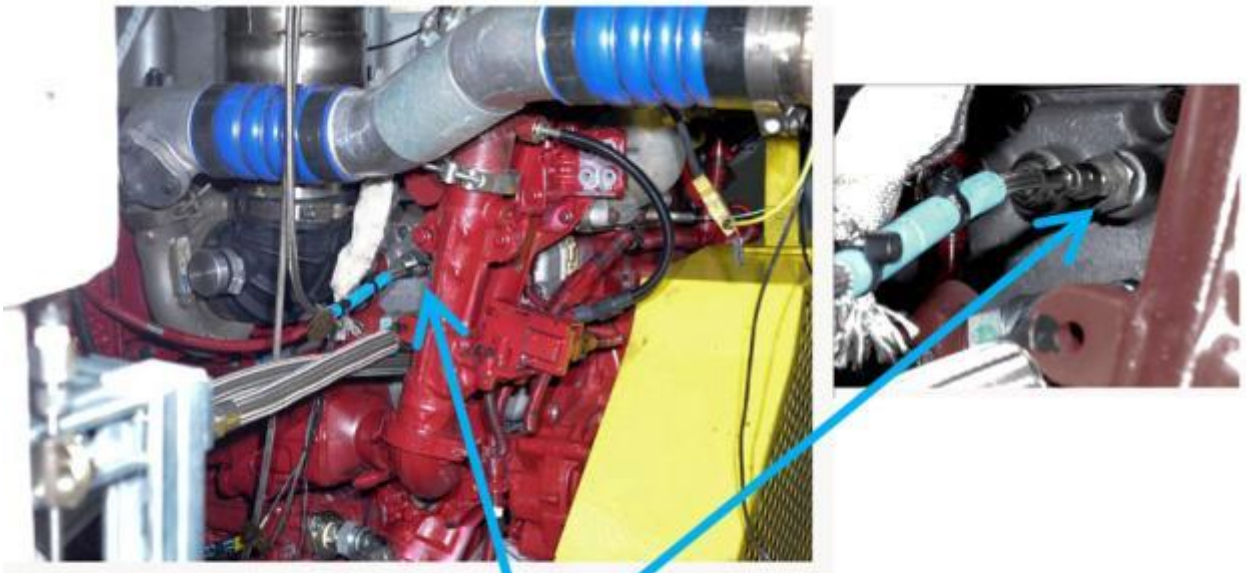

P_COOLANT_PUMP

FIG A5.31 Coolant Pump Pressure



P_FUEL_GALLERY

FIG A5.32 Fuel Gallery Pressure



P_OIL_JET

FIG A5.33 Oil Jet Pressure

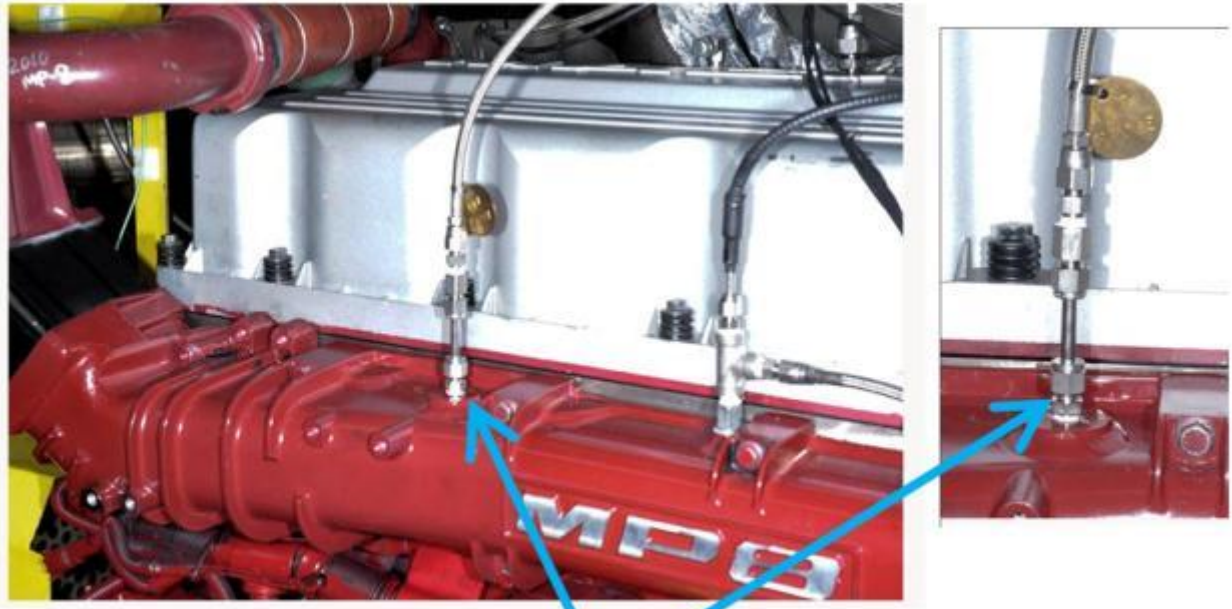

INTAKE MANIFOLD PROBE

FIG A5.34 Intake Manifold Probe



EPA2010 MP7/MP8 Engine Sensors

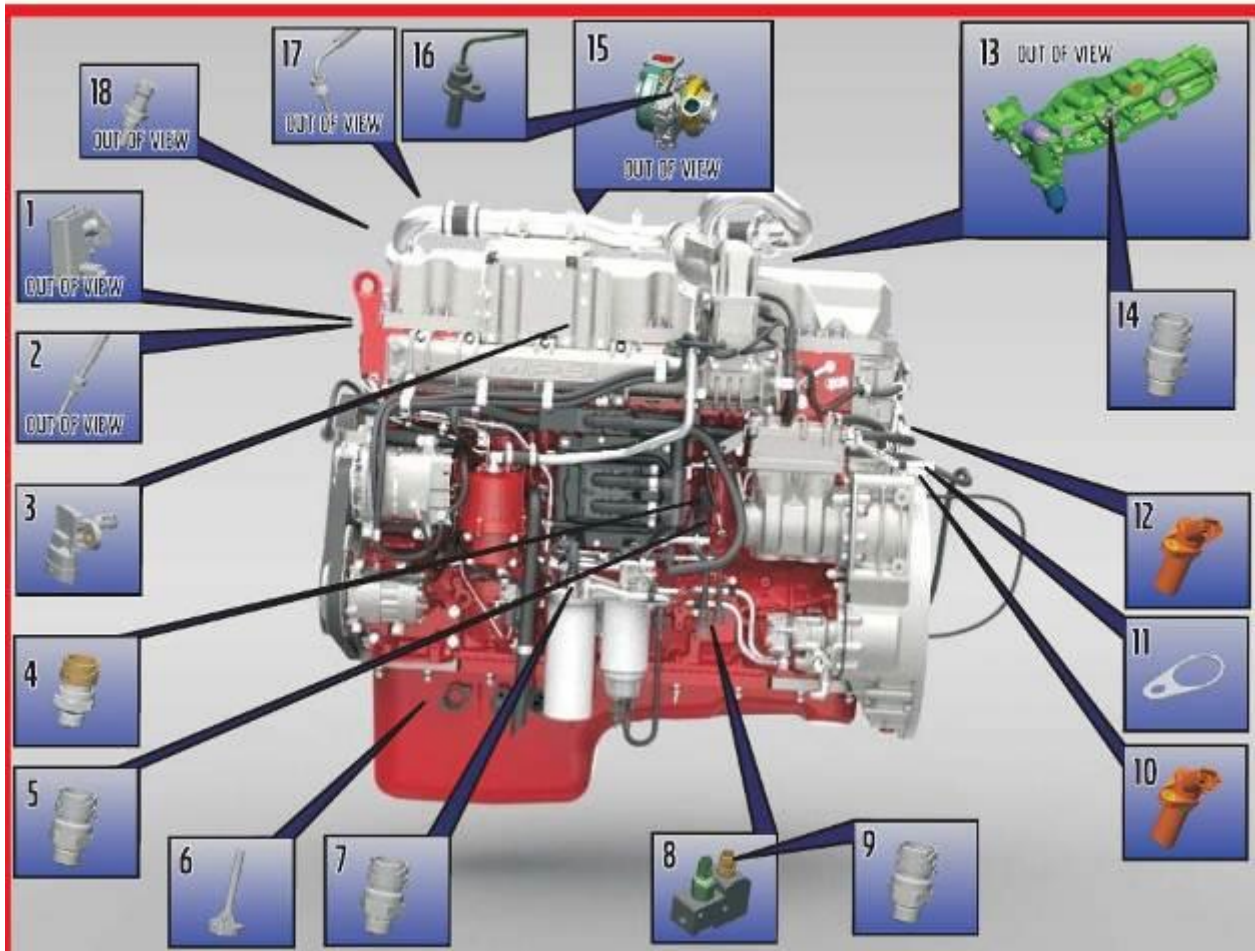

Fig. A5.35 EPA 2010 MP7/MP8 Engine Sensors

Table A5.1 Engine Sensors

#1 – EGR Delta Pressure Sensor - Must use sensor PN# 21713917 with new harness.



EPA2010 MP7/MP8 Engine Sensors

<u>Position</u>	<u>Description</u>	<u>Part number</u>
1.	EGR Delta Pressure Sensor	21304786
2.	EGR Temperature Sensor	21164790
3.	Intake Air Temperature / Boost Pressure Sensor	21097978
4.	Crankcase Pressure Sensor	20796744
5.	Engine Oil Pressure Sensor	21302639
6.	Engine Oil Level / Temperature Sensor	21042447
7.	Fuel Pressure Sensor	21302639
8.	Fuel Control Solenoid	20942984
9.	Aftertreatment Fuel Pressure Sensor	21302639
10.	Crankshaft Speed Sensor	20513343
11.	Shim	20556179
12.	Camshaft Speed Sensor	20513343
13.	Engine Oil Thermal Management System	Check Per VIN
14.	OBD Oil Pressure Sensor	21302639
15.	Turbocharger	Check Per VIN
16.	Turbine Shaft Speed Sensor	24427413
17.	Turbocharger Discharge Temperature Sensor	21164792
18.	Engine Coolant Temperature Sensor	20513340

NOTE: Images, Locations and Part numbers are for reference only!
Refer to the VIN number in Impact for the latest information.

DATE: 9/08/2009 PUBLICATION: PV776-SENSOR10-MP7-MP8

NOTES

- 1.) FYI - #4 and #5 Position sensors - are reversed for position on MP8 Engine /Sensor display above.
- 2.) #6 sensor: the correct PN# is 21521353. Remove sensor from oil pan.
- 3.) #13 – is not used
- 4.) #14 – is not used
- 5.) **Ambient Air Temperature Sensor to be left disconnected**

A6. PROCUREMENT OF TEST MATERIALS

A6.1 Throughout this test method, references are made to necessary hardware, reagents, materials and apparatus. In many cases, for the sake of uniformity and ease of acquisition, certain suppliers are named. If substitutions are deemed appropriate for the specified suppliers, obtain permission to substitute in writing from the TMC before such substitutions will be considered to be *equivalent*. The following entries represent a consolidated listing of the ordering information necessary to complete the references found in the text.

A6.2 The test engine and EU6 cylinder heads (P/N 21995786) and cylinder head kit (P/N 22251160) are available from:
Mack Trucks, Inc.
13302 Pennsylvania Avenue
Hagerstown, MD 21742

A6.2.1 The intake manifold, oil pump, EGR venturi unit, and injector nozzles (P/N 736GB419M3) and the parts shown in **Table A6.1** are available from:

TABLE A6.1 New Parts for Each Rebuild

Part Name	Mack Part Number	Quantity
Piston	21170742 P06	6
Liner	20852790 P05	6
Top Ring	21251596 P03	6
Second Ring	20590309 P32	6
Oil Ring	20568155 P34	6
Pin	20569833 P32	6
Snap Rings	914531 P01	12
Liner Seal – top at flange	470922 P03	6
Liner Seal(lower top and middle)	470190 P05	12
Liner Seal – lower – bottom	21430623 P01	6
Main Bearings – Upper	20530902	7
Main Bearings – Lower	20530900	7
Rod Bearings – Upper	20508264	6
Rod Bearings – Lower	20530094	6
Thrust Washer (4 pieces/pack)	21267844	1
Cable Tie	98372	1
Seal	20938963	1
Gasket	18665	1
Gasket	3979639	1
Retainer	8131393	1
Sealing	21185132	1
Washer	21274699	1
Gasket	20855371	1
Sealing Strip	20538793	1
Gasket	20841816	1
Sealing Strip	21298915	1
Cylinder Head Gasket	21510072	1
Gasket	20850815	1
Gasket	20781146	1
Gasket	20817742	1
O-Ring	967343	1
Sealing	20805850	1
Sealing Ring	21532258	1
O-Ring Kit	276948	1

A6.3TEI

12718 Cimarron Path
San Antonio, TX 78249-3423

A6.4 *Air Filtration*—Mack air filter element (p/n 57MD33) and Mack air filter housing (p/n 2MD3183) are available from Mack Trucks, Inc.

A6.5 Cleaning solvent and Pentane are available from local petroleum product suppliers.

A6.6 Ultra-Low Sulfur Diesel Fuel is available from:

Chevron Phillips Chemical Company LP
10001 Six Pines Drive, Suite 4036B
The Woodlands, TX 77387-4910
Ph: 832-813-4859
Fax: 832-813-4907
Email: fuels@cpchem.com

A6.7 Keil Probes are available from United Sensor Corp., 3 Northern Blvd., Amherst, NH 03031.

A6.8 Bulldog Oil is available from local Volvo/Mack Truck dealers.

A6.9 Honing and cutting oil is available from local industrial or automotive supply shops.



FIG A6.1 Sleeve replacing Thermostat

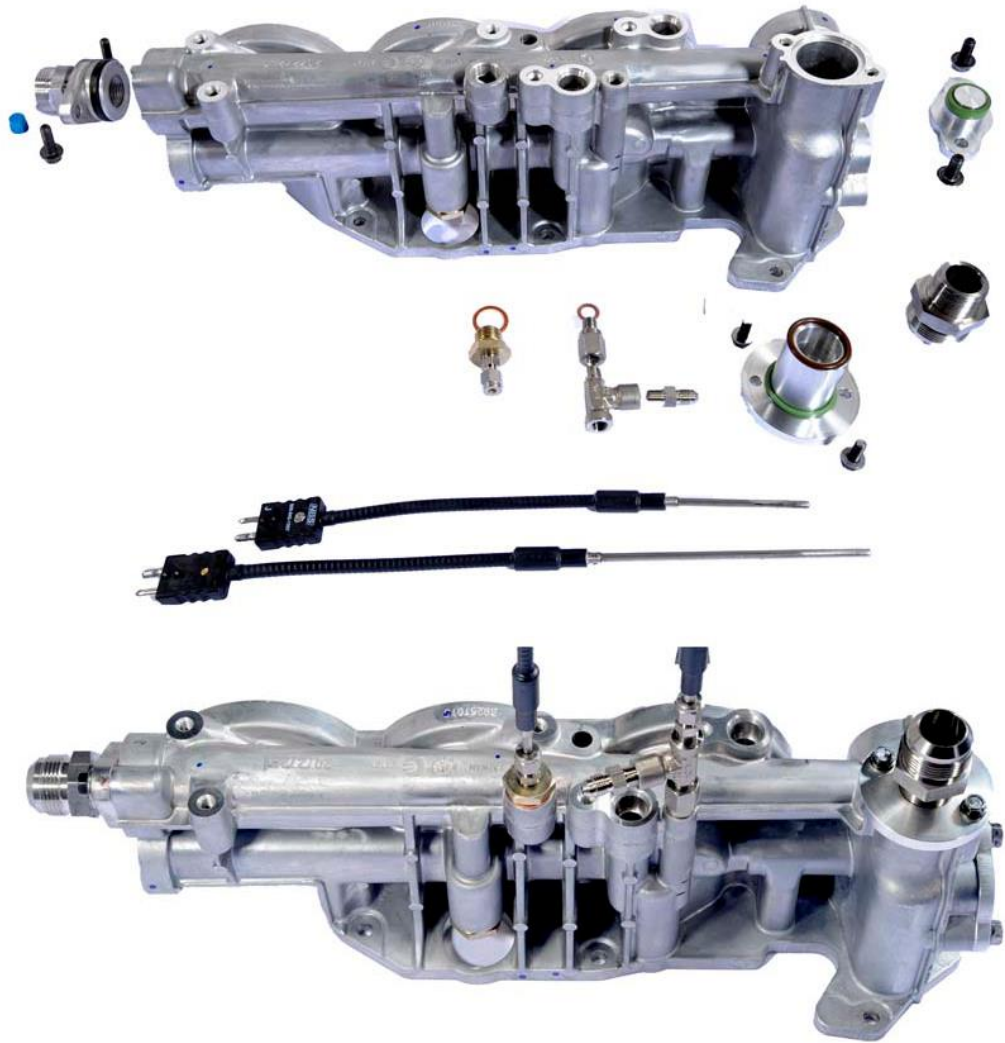

FIG A6.2 Modified US07 Oil Filter Housing



FIG A6.3 US07 Oil Filter Housing Fittings

A7. Quality Index and Operational Data Review

A7.1 Quality Index Calculation

A7.1.1 Calculate Quality Index (QI) for all control parameters in accordance with the DACA II Report. Be sure to account for missing or bad quality data in accordance with the DACA II Report as well.

A7.1.2 Use the U, L, Over Range, and Under Range values shown in [Table A7.1](#) for the QI calculations.

TABLE A7.1 Quality Index and Average Calculation Values

Control Parameter	Units	Quality Index Threshold	Quality Index U & L Values		Over & Under Range Values	
			U	L	Low	High
Speed	r/min	0.000	1502.5	1497.5	1350	1650
Fuel Flow	kg/h	0.000	69.0	67.0	8.0	128.0
Coolant Out Temp.	°C	0.000	110.7	109.3	68.0	152.0
Oil Gallery Temp.	°C	0.000	130.3	129.7	112.0	148.0
Intake Air Temp.	°C	0.000	30.6	29.4	-6.0	66.0
Inlet Manifold Temp.	°C	0.000	78.8	77.2	30.0	126.0
EGR Gas Out Temp.	°C	0.000	121.0	119.0	60.0	180.0
Fuel In Temp.	°C	0.000	35.5	34.5	5.0	65.0
Inlet Air Pressure	kPaA	0.000	94.5	93.5	64.0	124.0
Exhaust Back Pressure	kPaA	0.000	115.7	114.9	91.3	139.3
Ranged Parameter	Units	Range	Over & Under Range Values			
					Low	High

Control Parameter	Units	Quality Index Threshold	Quality Index U & L Values		Over & Under Range Values	
			U	L	Low	High
Inlet Manifold Pressure	kPaG	232 ± 5			0.0	532.0
Intake CO ₂	%	2.01 to 2.11			1.7	2.4
Engine Coolant Blanket Pressure	kPaG	99 to 107			0	343.0
EGR Coolant Blanket Pressure	kPaG	99 to 140			0	1349.5
Crankcase Pressure	kPa	-0.3 to 0.3			-18.0	18.0

^A U and L values for speed, fuel flow, inlet manifold temperature, coolant out temperature, and oil gallery temperature are split by test phase.

A7.1.3 Round the calculated QI values to the nearest 0.001.

A7.1.4 Report the QI values on the appropriate form.

A7.2 Averages

A7.2.1 Calculate averages for all control, ranged, and non-control parameters and report the values on the appropriate form.

A7.2.2 The averages for control and non-control parameters are not directly used to determine operational validity but they may be helpful when an engineering review is required (refer to A7.4).

A7.3 Determining Operational Validity

A7.3.1 QI threshold values for operational validity are shown in Table A7.1. Specifications for all ranged parameters are shown in Table A7.1.

A7.3.1.1 A test with EOT QI values for all control parameters equal to or above the threshold values and with averages for all ranged parameters within specifications is operationally valid, provided that no other operational deviations exist that may cause the test to be declared invalid.

A7.3.1.2 Conduct an engineering review (see A7.4) to determine the operational validity of a test with any control parameter QI value less than the threshold value.

A7.3.1.3 With the exception of crankcase pressure, a test with a ranged parameter average value outside the specification is invalid. Conduct an engineering review to determine operational validity for a test with crankcase pressure outside the specification.

A7.4 Engineering Review

A7.4.1 Conduct an engineering review when a control parameter QI value is below the threshold value. A typical engineering review involves investigation of the test data to determine the cause of the below threshold QI. Other affected parameters may also be included in the engineering review. This can be helpful in determining if a real control problem existed and the possible extent to which it may have impacted the test. For example, a test runs with a low QI for fuel flow. An examination of the fuel flow data may show that the fuel flow data contains several over range values. At this point, an examination of exhaust temperatures may help determine whether the instrumentation problem affected real fuel flow versus affecting only the data acquisition.

A7.4.2 For reference oil tests, conduct the engineering review jointly with the TMC. For non-reference oil tests, optional input is available from the TMC for the engineering review.

A7.4.3 Determine operational validity based upon the engineering review and summarize the decision in the comment section on the appropriate form. It may be helpful to include any supporting documentation at the end of the test report. The final decision regarding operational validity rests with the laboratory.

A8. BREAK-IN, START-UP, SHUTDOWN, AND TRANSITION PROCEDURES

A8.1 The break-in sequence is shown in **Table A8.1**.

TABLE A8.1 Break-In Sequence

Step:	1	2	3	4	5	6	7	8	
*Time (minutes):	2	4	4	10	30	4	4	2	
Speed, rpm	1000	1200	1500	1500	1500	1500	1200	1000	
Torque, N·m	0	500	1200	2000	2200	1200	500	0	
Fuel Flow, kg/h (nominal)	NA	NA	NA	NA	(68.0)	NA	NA	NA	
Coolant Out Temp, °C	80	88	90	105	110	105	88	80	
Fuel In Temp, °C	35	35	35	35	35	35	35	35	
Inlet Air Temp, °C	30	30	30	30	30	30	30	30	
Intercooler Out Temp, °C	30	36	40	40	NA	40	36	30	
Intake Manifold Temp, °C	NA	NA	NA	NA	78	NA	NA	NA	
Oil Gallery Temp, °C	80	90	100	120	130	110	90	80	
EGR Coolant In Temperature, °C	50	60	80	100	NA	80	60	50	
EGR Gas Out Temperature, °C	NA	NA	NA	NA	120	NA	NA	NA	
Intake Air Press, kPaA	Valve 100% Open		98.0	96.0	94.0	98.0	Valve 100% Open		
Exhaust BackPress, kPaA	Valve 100% Open		107.3	111.3	115.3	107.3	Valve 100% Open		
Engine Coolant Blanket Press, kPaG	99-107								
EGR Coolant Blanket Press, kPaG	99-107								
Oil Scale	Off			On			Off		
Front Cooling Fan	On							Off	

*: Time includes a 30s linear ramps between Steps

A8.2 The Warm Up and Cool Down sequence is shown in **Table A8.2**.

TABLE A8.2 Warm-Up and Cool Down Sequence

Step:	1	2	3	4	5
* Time (minutes):	2	4	4	5	3
Speed, rpm	1000	1200	1200	1500	1500
Torque, N·m	0	400	1200	2000	2200
Fuel Flow, kg/h (nominal)	NA	NA	NA	NA	(68.0)
Coolant Out Temp, °C	80	88	90	105	110
Fuel In Temp, °C	35	35	35	35	35
Inlet Air Temp, °C	30	30	30	30	30
Intercooler Out Temp, °C	30	36	40	40	NA
Intake Manifold Temp, °C	NA	NA	NA	NA	78
Oil Gallery Temp, °C	80	90	100	120	130
EGR Coolant In Temperature, °C	50	60	80	100	NA
EGR Gas Out Temperature, °C	NA	NA	NA	NA	120
Intake Air Press, kPaA	Valve 100% Open		98.0	96.0	94.0
Exhaust BackPress, kPaA	Valve 100% Open		107.3	111.3	115.3
Engine Coolant Blanket Press, kPaG	99-107				
EGR Coolant Blanket Press, kPaG	99-107				
Oil Scale	Off		On		
Front Cooling Fan	On				

*: Time includes a 30s linear ramps between Steps

- 1) Warm up consists of steps 1-5
- 2) Cool down consists of steps 4-1

A9. Fault Codes

Mack T-13 Running Test Fault Codes						
Description	MID	PID	PPID	SID	PSID	FMI
Ambient Air Temperature	128	171				12
Clock	128	251				2
Clock	128	251				9
Clock	128	251				12
Clock	128	251				13
Compressor Recirculation Valve	128		330			5
Date	128	252				9
DPF Switch	128				114	9
Engine Oil Burn Valve	128			85		5
Engine Oil Level	128	98				5
Fan Clutch Output	128			33		5
NOX Sensor Gas Intake	128		348			9
Nox Sensor Gas Outlet	128		270			9
Program Memory	128			240		14
Speed Sensor Calibration	128	228				11
Thermostat Bypass Valve	128				72	5
Total Vehicle Distance	128	245				9

A10. SAFETY PRECAUTIONS

A10.1 General

A10.1.1 The operating of engine tests can expose personnel and facilities to a number of safety hazards. It is recommended that only personnel who are thoroughly trained and experienced in engine testing should undertake the design, installation and operation of engine test stands.

A10.1.2 Each laboratory conducting engine tests should have their test installation inspected and approved by their Safety Department. Personnel working on the engines should be provided with proper tools, be alert to common sense safety practices, and avoid contact with moving, and hot engine parts, or both. Guards should be installed around all external moving or hot parts. When engines are operating at high speeds, heavy duty guards are required and personnel should be cautioned against working alongside the engine and coupling shaft. Barrier protection should be provided for personnel. All fuel lines, oil lines, and electrical wiring should be properly routed, guarded, and kept in good order. Scraped knuckles, minor burns, and cuts are common if proper safety precautions are not taken. Safety masks or glasses should always be worn by personnel working on the engines and no loose or flowing clothing, including long hair or other accessory to dress which could become entangled, should be worn near running engines.

A10.1.3 The external parts of the engines and the floor area around the engines should be kept clean and free of oil and fuel spills. In addition, all working areas should be free of tripping hazards. Personnel should be alert for leaking fuel or exhaust gas. Leaking fuel represents a fire hazard and exhaust gas fumes are noxious. Containers of oil or fuel cannot be permitted to accumulate in the testing area.

A10.1.4 The test installation should be equipped with a fuel shut-off valve which is designed to automatically cutoff the fuel supply to engine when the engine is not running. A remote station for cutting off fuel from the test stand is recommended. Suitable interlocks should be provided so that the engine is automatically shut-down when any of the following events occur: engine or dynamometer water temperature becomes excessive; engine loses oil pressure; dynamometer loses field current; engine over-speeds; exhaust system fails; room ventilation fails; or the fire protection system is activated.

A10.1.5 Consider an excessive vibration pickup interlock if equipment operates unattended. Fixed fire protection equipment should be provided.

A10.1.6 Normal precautions should be observed whenever using flammable solvents for cleaning purposes. Make sure adequate fire-fighting equipment is immediately accessible.

A11. T-13 RING AND LINER OUTLIER METHODOLOGY

A11.1 Average Top Ring Mass Loss

A11.1.1 Calculate the average and standard deviation of top ring mass loss using all rings and report the data on the appropriate forms. Use Practice E178 Section 6.1 and Table 1, two-sided test at Upper 2.5% Significance Level with 6 observations (1.887) to determine if any top ring mass loss values are outliers. Remove a maximum of one outlier. Calculate outlier screened average mass loss, \bar{x} , and the standard deviation of the mass loss, s , for the group and report on the appropriate forms.

A11.2 Average Cylinder Liner Wear

A11.2.1 Calculate the average and standard deviation of cylinder liner wear using all liners and report the data on the appropriate forms. Use Practice E178 Section 6.1 and Table 1, two-sided test at Upper 2.5% Significance Level with 6 observations (1.887) to determine if any cylinder liner wear values are outliers. Remove a maximum of one outlier. Calculate outlier screened cylinder liner wear, \bar{x} , and the standard deviation of the liner wear, s , for the group and report on the appropriate forms.

A12. Oil Consumption Sampling Schedule

Test Hours	Operator	24	48	72	96	120	144	168	192	216	240	252	264	276	288	300	312	324	336	348	360	
1 Full Mark-Scale mass, g																						
2 Scale mass at end of interval, g																						
3 Interval consumption, g	1 - 2																					
3A Remove 140 mL purge, Operator																						
3B Return purge, Operator																						
4 Mass of sample removed, g																						
5 Mass to be drained, g	6 - 3 - 4																					
6 New oil additions, g		750	750	750	750	750	750	750	750	750	750		750		750		750		750		750	
Oil Sampling Log sheet Instructions: a. Complete the log sheet in Sequence # 1-6 . b. The full mark is the mass of the scale at 4 h or after the first 4 h of uninterrupted operation following the start-of-test, whichever comes first. The mass readings of the external scale are recorded by the cell computer every 6 min. c. All samples must be taken before new oil is added. d. Return the entire purge to the engine except at 360 h or end-of-test . e. whichever comes first . f. At EOT, obtain the Blowby Tank Drain and total mass of oil drained from engine, oil filters and oil cooler in grams.																						

ASTM International takes no position respecting the validity of any patent rights asserted in connection with any item mentioned in this standard. Users of this standard are expressly advised that determination of the validity of any such patent rights, and the risk of infringement of such rights, are entirely their own responsibility.

This standard is subject to revision at any time by the responsible technical committee and must be reviewed every five years and if not revised, either reapproved or withdrawn. Your comments are invited either for revision of this standard or for additional standards and should be addressed to ASTM International Headquarters. Your comments will receive careful consideration at a meeting of the responsible technical committee, which you may attend. If you feel that your comments have not received a fair hearing you should make your views known to the ASTM Committee on Standards, at the address shown below.

This standard is copyrighted by ASTM International, 100 Barr Harbor Drive, PO Box C700, West Conshohocken, PA 19428-2959, United States. Individual reprints (single or multiple copies) of this standard may be obtained by contacting ASTM at the above address or at 610-832-9585 (phone), 610-832-9555 (fax), or service@astm.org (e-mail); or through the ASTM website (www.astm.org). Permission rights to photocopy the standard may also be secured from the ASTM website (www.astm.org/COPYRIGHT/).