



Volvo/Mack CPD Report

T8/T11/T12/T13

Volvo/Mack CPD Report Contents

- Issues/Updates/Observations
 - New Parts Batches
 - T-11/T-12 Liners
 - T-11/T-12 Skirts
 - Covert Rods
 - Federal Mogul Update
- Inventory and Availability
 - Critical Parts
 - Miscellaneous Parts



Volvo/Mack T-11/T-12 New Parts Batches

- TEI is ordering enough of all critical T-11/T-12 parts to last until 2026.
- Ordering now will help prevent parts shortages in the future.



Volvo/Mack

T-11/T-12 New Parts Batches

- T-11/T-12 parts that are currently batched that we cannot order as a batch anymore:
 - 2nd and Oil rings
 - Main bearings
 - Connecting rod bearings



Volvo/Mack T-11/T-12 New Parts Batches

- TEI currently has 500 new crowns with a nearly 100% acceptance rate
- An order is placed for 2,150 top rings (Batch Y) and should arrive in ~14 weeks.



Volvo/Mack T-11/T-12 Liners

- TEI currently has 432 of the 3,000 liners that were ordered.
- The surface finish measurements are comparable to Batch “V”.

	T-12 Liners - Batch V vs W						
	Average of Ra	Average of Rk	Average of MR1	Average of MR2	Average of Rpk	Average of Rvk	Average of VO
Batch V	17.1	46.7	7.5	84.0	17.0	38.8	0.0107
Batch W	16.4	41.7	6.5	81.9	12.2	40.1	0.0092



Volvo/Mack T-11/T-12 Liners

- The new liners have spots that are from leftover machining fluid.

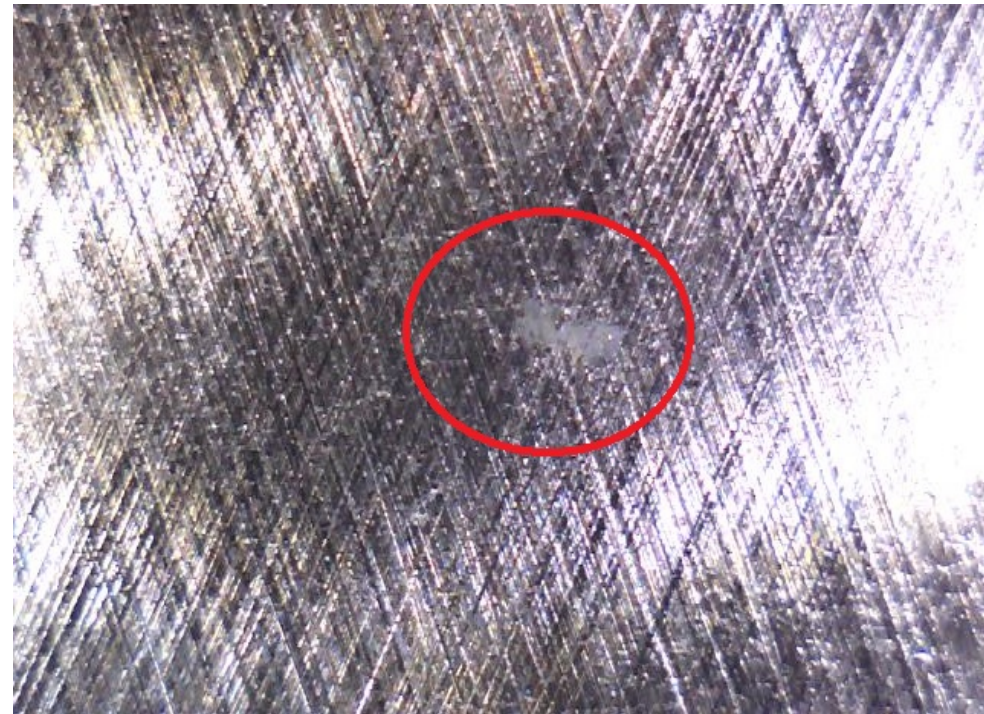
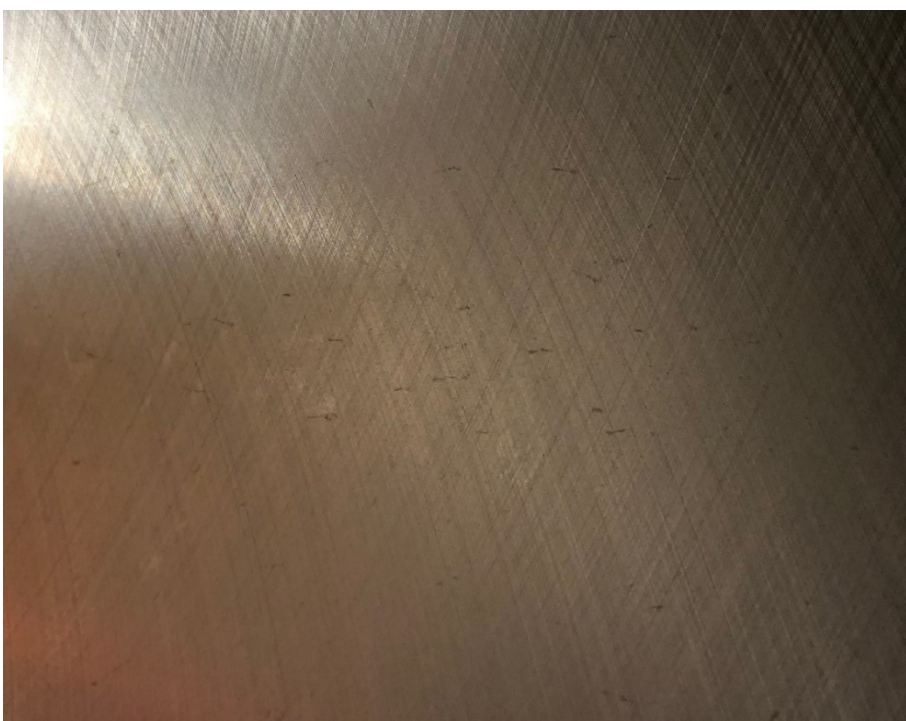

Volvo/Mack T-11/T-12 Skirts

- TEI currently has 1,680 new skirts.
- 10 out of the 10 measured skirts were out of spec.
- FM has been made aware of the problem and has been sent skirts for review.



Volvo/Mack T-11/T-12 Skirts

- The nominal diameters for D1 and D3 are based on the measured D2 diameter
- D1, D3 or both were out of spec on 10/10 skirts

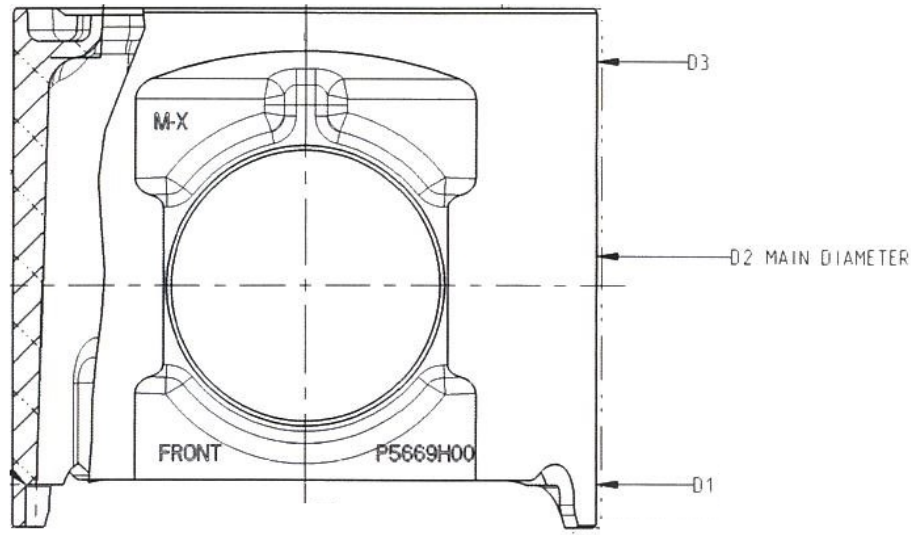

Volvo/Mack T-11/T-12 Covert Connecting Rods

- TEI is currently out of T-11/T-12 Covert rods.
- The current ETA is August 2019
- These will be increasing in price from \$980.40 to \$1,039.20



Side Note

- Federal Mogul was recently bought by Tenneco.
- There is little to no overlap between Tenneco and Federal Mogul, so no change is expected.

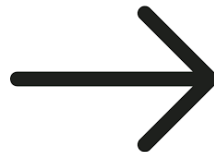

Volvo/Mack Kit Parts Inventory

Critical Parts Inventory

Part Description	Test Type	Part Number	Batch/Date	In Stock	~Reject %
Cylinder Liner	T8, T11, T12	509GC471	V	277	10%
Piston Crown	T11, T12	240GC5125M	F	500	1%
Piston Skirt	T8,T11, T12	240GC5119M	B	1,680	100%
Piston Assembly	T8	215SB232A	n/a	11	0%
Top Ring	T8, T11, T12	349GC3107	X	1,075	5%
			V	4	n/a
2nd Ring	T8, T11, T12	349GC3108	W	403	5%
Oil Ring	T8, T11, T12	350GC343	W	403	5%
Connecting Rod Bearings	T8, T11, T12	*20705743	Y	1,449	25%
Main Bearings (full sets)	T8, T11, T12	*25503508	P	213	15%

Cylinder Liner	T13	21334768	B	1116	1%
Piston	T13	**21330684	n/a	120	50%
Top Ring	T13	**21330684	n/a	120	10%
2nd Ring	T13	**21330684	n/a	120	10%
Oil Ring	T13	**21330684	n/a	120	10%
Connecting Rod Bearings	T13	**20580558	B	156	10%
Main Bearing (full sets)	T13	**20530916	n/a	26	10%



Volvo/Mack Miscellaneous Parts Inventory

Miscellaneous Parts Inventory

Test Type	Part Description	Part Number	In Stock
T8	Injection Pump "calibrated"	313GC5212P16X	0
	Injector Nozzle	736GB343P2X	27
T11	EGR Cooler	19GBX52	6
	Injection Nozzle	736GB411M2	10
	Modine Intercooler	5424-03928031	2
	Turbo Small	631GC5145M3 316686-S400	12
T12	EGR Cooler	28GB519	0
	Injection Nozzle	736GB419M3	11
	Modine Intercooler	5424-1A166566D	2
	Turbo Small	631GC5176CM7	0
T11 and T12	Camshaft Kit	57GC2209A	0
	Cylinder Head - Low Swirl	732GB3499M	2
	Electronic Actuator	9MS42	1
	Engine - Bare Block	239GB5551M	0
	Engine - Basic Engine	86SB3536N	1
	Exhaust Manifold Assembly (front and rear)	M10104GC5164M	3
	Fuel Injector Line	HL69-151	20
	Fuel Injector Line	HL69-152	22
	Full Flow Oil Filter	485GB3236	3
	High Temperature Hose	3101632M	327
	Intake Manifold Assembly	M10105GCX4332/5212	1
	Lifter Assembly	72GC373A	0
	Machine Elbow	454GC5236	20
	Oil Cooler End Caps	TEI-T12OCEC	1
	Oil Filter Housing	27GB528M2	0
	Oil Pump Assembly - Low Flow - 9-tooth internal gears	315GC465BM	2
	Connecting Rod	367GC4243M2	0
	Covert Connecting Rods	20706148N	9
	Short EGR Exhaust Probe	TEGR0005	3
	Turbo Gasket	TEIEX201064AM	78
	Turbo Large	3801847R	0
	Venturi	762GBX433SS	



Questions ?

