

This document is not an ASTM standard; it is under consideration within an ASTM technical committee but has not received all approvals required to become an ASTM standard. You agree not to reproduce or circulate or quote, in whole or in part, this document outside of ASTM Committee/Society activities, or submit it to any other organization or standards bodies (whether national, international, or other) except with the approval of the Chairman of the Committee having jurisdiction and the written authorization of the President of the Society. If you do not agree with these conditions please immediately destroy all copies of the document. Copyright ASTM International, 100 Barr Harbor Drive, West Conshohocken, PA 19428. All Rights Reserved.



6th Development Group DRAFT

Date: 10/03/2022
To: Subcommittee D02.BO.02 members
Tech Contact: Sid Clark, slclark@comcast.net
Work Item #: WK 72778
Ballot Action: New Standard Test Method
Rationale: A new standardized test method for Diesel engine oil classification and future approval.

Designation: DXXXX – XX

Standard Test Method for Evaluation of Diesel Engine Oils in Ford 6.7L Diesel Engine¹

This standard is issued under the fixed designation DXXXX; the number immediately following the designation indicates the year of original adoption or, in the case of revision, the year of last revision. A number in parentheses indicates the year of last reapproval. A superscript epsilon (^ε) indicates an editorial change since the last revision or reapproval.

INTRODUCTION

Portions of this test method are written for use by laboratories that make use of ASTM Test Monitoring Center (TMC)² services (See [Annex A1](#)).

The TMC provides reference oils, engineering and statistical services to laboratories that desire to produce test results that are statistically similar to those produced by laboratories previously calibrated by the TMC.

In general, the Test Purchaser decides if a calibrated test stand is to be used. Organizations such as the American Chemistry Council require that a laboratory utilize the TMC services as part of their test registration process. In addition, the American Petroleum Institute (API) and the Gear Lubricant Review Committee of the Lubricant Review Institute (SAE International) require that a laboratory use the TMC services in seeking qualification of oils against their specifications.

The advantage of using the TMC services to calibrate test stands is that the test laboratory (and hence the Test Purchaser) has an assurance that the test stand was operating at the proper level of test severity. It should also be borne in mind that results obtained in a non-calibrated test stand may not be the same as those obtained in a test stand participating in the ASTM TMC services process. Laboratories that chose not to use the TMC services may simply disregard these portions.

1. Scope

1.1 This test method covers an engine test procedure for evaluating diesel engine oils for valve-train wear characteristics in an engine running on ultra-low sulfur diesel fuel. This test method is commonly referred to as the Ford 6.7L Valve-Train Wear (VTW) Test.

¹ This test method is under the jurisdiction of ASTM Committee D02 on Petroleum Products, Liquid Fuels, and Lubricants and is the direct responsibility of Subcommittee D02.B0 on Automotive Lubricants.

² ASTM Test Monitoring Center, 203 Armstrong Drive, Freeport, PA. 16229, USA. Tel. +1 412 365 1000. <https://www.astmtmc.org/>

1.2 The values stated in SI units are to be regarded as standard. No other units of measurement are included in this standard.

1.2.1 *Exception*—Where there is no direct SI equivalent, such as the units for screw threads, National Pipe Threads/ diameters, tubing size, and single source supply equipment specifications.

1.3 *This standard does not purport to address all of the safety concerns, if any, associated with its use. It is the responsibility of the user of this standard to establish appropriate safety and health practices and determine the applicability of regulatory limitations prior to use.* See **Annex A2** for specific safety precautions.

2. Referenced Documents

2.1 ASTM Standards:³

D86 Test Method for Distillation of Petroleum Products and Liquid Fuels at Atmospheric Pressure

D93 Test Method for Flash Point by Pensky-Martens Closed Cup Tester

D97 Test Method for Pour Point of Petroleum Products D130 Test Method for Corrosiveness to Copper from

Petroleum Products by Copper Strip Test

D130 Test Method for Corrosiveness to Copper from Petroleum Products by Copper Strip Test

D235 Specification for Mineral Spirits (Petroleum Spirits) (Hydrocarbon Dry Cleaning Solvent)

D240 Standard Test Method for Heat of Combustion of Liquid Hydrocarbon Fuel by Bomb Calorimeter

D287 Test Method for API Gravity of Crude Petroleum and Petroleum Products (Hydrometer Method)

D445 Test Method for Kinematic Viscosity of Transparent and Opaque Liquids (and Calculation of Dynamic Viscosity)

D482 Test Method for Ash from Petroleum Products

D524 Test Method for Ramsbottom Carbon Residue of Petroleum Products

D613 Test Method for Cetane Number of Diesel Fuel Oil D664 Test Method for Acid Number of Petroleum Products

by Potentiometric Titration

D974 Test Method for Acid and Base Number by Color-Indication Titration

D975 Specification for Diesel Fuel Oils

D1319 Test Method for Hydrocarbon Types in Liquid Petroleum Products by Fluorescent Indicator Adsorption

D2274 Test Method for Oxidation Stability of Distillate Fuel Oil

D2500 Test Method for Cloud Point of Petroleum Products and Liquid Fuels

D3524 Test Method for Diesel Fuel Diluent in Used Diesel Engine Oils by Gas Chromatography

D4052 Test Method for Density, Relative Density, and API Gravity of Liquids by Digital Density Meter

D4057 Standard Practice for Manual Sampling of Petroleum and Petroleum Products

D4175 Terminology Relating to Petroleum Products, Liquid Fuels, and Lubricants

D4177 Standard Practice for Automatic Sampling of Petroleum and Petroleum Products

D4485 Standard Specification for Performance of Engine Oils

D4737 Calculated Cetane Index by Four Variable Equation

D4739 Test Method for Base Number Determination by Potentiometric Hydrochloric Acid Titration

D4809 Standard Test Method for Heat of Combustion of Liquid Hydrocarbon Fuel by Bomb Calorimeter (Precision Method)

D4951 Determination of Additive Elements in Lubricating Oils by Inductively Coupled Plasma Atomic Emission Spectrometry

D5185 Test Method for Multielement Determination of Used and Unused Lubricating Oils and Base Oils by Inductively Coupled

Plasma Atomic Emission Spectrometry (ICP- AES)

D5186 Test Method for Determination of the Aromatic Content and Polynuclear Aromatic Content of Diesel Fuels and Aviation

Turbine Fuels by Supercritical Fluid Chromatography

D5453 Test Method for Determination of Total Sulfur in Light Hydrocarbons, Spark Ignition Engine Fuel, Diesel Engine Fuel, and

Engine Oil by Ultraviolet Fluorescence

D5800 Evaporation Loss of Lubricating Oils by the Noack Method

D5967 Test Method for Evaluation of Diesel Engine Oils in T-8 Diesel Engine

D7094 Standard Test Method for Flash Point by Modified Continuously Closed Cup (MCCCFP) Tester

E29 Practice for Using Significant Digits in Test Data to Determine Conformance with Specifications

E168 Practices for General Techniques of Infrared Quantitative Analysis

E380 Use of the International System of Units (SI) (The Modernized Metric System)

³ For referenced ASTM standards, visit the ASTM website, www.astm.org, or contact ASTM Customer Service at service@astm.org. For *Annual Book of ASTM Standards* volume information, refer to the standard's Document Summary page on the ASTM website.

2.2 SAE Standards⁴

J300 Engine Oil Viscosity Classification

J304 Engine Oil Tests

3. Terminology

3.1 Definitions:

3.1.1 *blind reference oil*, n—a reference oil, the identity of which is unknown by the test facility.

3.1.1.1 *Discussion*—This is a coded reference oil that is submitted by a source independent from the test facility. D4175

3.1.2 *break-in*, v—in *internal combustion engines*, the running of a new engine under prescribed conditions to help stabilize engine response and help remove initial friction characteristics associated with new engine parts. D4175

3.1.3 *calibrate*, v—to determine the indication or output of a measuring device with respect to that of a standard. D4175

3.1.4 *calibrated test stand*, n—a test stand on which the testing of reference material(s), conducted as specified in the standard, provided acceptable test results.

3.1.4.1 *Discussion*—In several automotive lubricant standard test methods, the ASTM Test Monitoring Center provides testing guidance and determines acceptability. D4175

3.1.5 *calibration test*, n—an engine test conducted on a reference oil under carefully prescribed conditions, the results of which are used to determine the suitability of the engine stand/laboratory for such tests on non-reference oils.

3.1.5.1 *Discussion*—A calibration test also includes tests conducted on parts to ensure their suitability for use in reference and non-reference tests. D4175

3.1.6 *candidate oil*, n—an oil that is intended to have the performance characteristics necessary to satisfy a specification and is intended to be tested against that specification. D4175

3.1.7 *engine oil*, n—a liquid that reduces friction or wear, or both, between the moving parts within an engine; removes heat particularly from the underside of pistons; and serves as combustion gas sealant for the piston rings.

3.1.7.1 *Discussion*—It may contain additives to enhance certain properties. Inhibition of engine rusting, deposit formation, valve train wear, oil oxidation, and foaming are examples. D4175

3.1.8 *exhaust gas recirculation (EGR)*, n—the mixing of exhaust gas with intake air to reduce the formation of nitrogen oxides (NO_x). D4175

3.1.9 *heavy-duty*, adj—in internal combustion engine operation, characterized by average speeds, power output and internal temperatures that are close to the potential maximums. D4175

3.1.10 *heavy-duty engine*, n—in *internal combustion engine types*, one that is designed to allow operation continuously at or close to its peak output.

3.1.11 *lubricant test monitoring system (LTMS)*, n—an analytical system in which ASTM calibration test data are used to manage lubricant test precision and severity (bias). D4175

3.1.11.1 *LTMS date*, n—the date the test was completed unless a different date is assigned by the TMC.

3.1.11.2 *LTMS time*, n—the time the test was completed unless a different time is assigned by the TMC.

3.1.12 *lubricant*, n—any material interposed between two surfaces that reduces the friction or wear, or both, between them. D4175

3.1.13 *non-reference oil*, n—any oil other than a reference oil; such as a research formulation, commercial oil or candidate oil. D4175

3.1.14 *non-standard test*, n—a test that is not conducted in conformance with the requirements in the standard test method; such as running on an uncalibrated test stand, using different test equipment, applying different equipment assembly procedures, or using modified operating conditions. D4175

3.1.15 *oxidation*, n—of engine oil, the reaction of the oil with an electron acceptor, generally oxygen, that can produce deleterious acidic or resinous materials often manifested as sludge formation, varnish formation, viscosity increase, or corrosion, or combination thereof. D4175

3.1.16 *quality index (QI)*, n—a mathematical formula that uses data from controlled parameters to calculate a value indicative of control performance. D4175

3.1.17 *quantity*, n—in the *SI*, a measurable property of a body or substance where the property has a magnitude expressed as the product of a number and a unit; there are seven, well-defined base quantities (length, time, mass, temperature, amount of substance, electric current and luminous intensity) from which all other quantities are derived (for example, volume whose SI unit is the cubic meter).

3.1.17.1 *Discussion*—Symbols for quantities must be carefully defined; are written in italic font, can be upper or lower case, and can be qualified by adding further information in subscripts, or superscripts, or in parentheses (for example, $t_{fuel} = 40\text{ }^{\circ}\text{C}$, where t is used as the symbol for the quantity Celsius temperature and t_{fuel} is the symbol for the specific quantity fuel temperature). D4175

⁴ Available from Society of Automotive Engineers, 400 Commonwealth Dr. Warrendale, PA. 15096-0001.

3.1.18 *reference oil*, n—an oil of known performance characteristics, used as a basis for comparison.

3.1.18.1 *Discussion*—Reference oils are used to calibrate testing facilities, to compare the performance of other oils, or to evaluate other materials (such as seals) that interact with oils. D4175

3.1.19 *Safety Data Sheet (SDS)*, n—a fact sheet summarizing information about material identification; hazardous ingredients; health, physical, and fire hazards; first aid; chemical reactivity's and incompatibilities; spill, leak, and disposal procedures; and protective measures required for safe handling and storage.

3.1.20 *standard test*, n—a test on a calibrated test stand, using the prescribed equipment in accordance with the requirements in the test method, and conducted in accordance with the specified operating conditions.

3.1.21 *test oil*, n—any oil subjected to evaluation in an established procedure.

3.1.21.1 *Discussion*—It can be any oil selected by the laboratory conducting the test. It could be an experimental product or a commercially available oil. Often it is an oil that is a candidate for approval against engine oil specifications (such as manufacturers' or military specifications, and so forth). D4175

3.1.22 *test parameter*, n—a specified component, property, or condition of a test procedure.

3.1.22.1 *Discussion*—Examples of components are fuel, lubricant, reagent, cleaner, and sealer; of properties are density, temperature, humidity, pressure, and viscosity; and of conditions are flow rate, time, speed, volume, length, and power. D4175

3.1.23 *test stand*, n—a suitable foundation (such as a bedplate) to which is mounted a dynamometer, and which is equipped with a suitable data acquisition system, fluids process control system, supplies of electricity, compressed air, and so forth, to provide a means for mounting and operating an engine in order to conduct a Ford Valvetrain Wear Test.

3.1.24 *wear*, n—the loss of material from a surface, generally occurring between two surfaces in relative motion, and resulting from mechanical or chemical action or a combination of both. D4175

3.2 *Definitions of Terms Specific to This Standard:*

3.2.1 *Degreasing Solvent*—Mineral spirits meeting the requirements of Specification D235, Type II, Class C for Aromatic Content (0 to 2) volume %, Flash Point (61°C, min) and Color (not darker than +25 on Saybolt Scale or 25 on Pt-Co Scale). (**Warning**-Combustible-Health hazard-see appropriate SDS). A Certificate of Analysis is required for each batch of solvent.

3.2.2 *new laboratory*, n—one that has never previously calibrated a test stand under this test method.

3.2.3 *new stand*, n—a test cell and support hardware which has never previously been calibrated under this test method.

3.3 *Acronyms:*

3.3.1 CAC—charge air cooler

3.3.2 CPD – central parts distributor

3.3.3 DACA II—data acquisition and control automation II

3.3.4 EGR—exhaust gas recirculation

3.3.5 EOT—end of test

3.3.6 ID—internal diameter

3.3.7 KV – Kinematic Viscosity

3.3.8 TMC² – Test Monitoring Center

3.3.9 SOT—start of test

3.3.10 ULSD – ultra low sulfur diesel fuel

3.3.11 VTW – Valve Train Wear

4. Summary of Method

4.1 This test method uses a MY2019 Ford Powerstroke⁵ 6.7L, 8-cylinder diesel engine with EGR removed.

4.2 The engine is disassembled down to a short block prior to each test and rebuilt with measured test components.

4.3 The test stand is equipped with appropriate accessories for measuring and controlling speed, torque, temperature, and pressures with a suitable data acquisition system to record various engine operating conditions.

4.4 Following an engine flush, power check, and secondary flushes, the engine runs a 200 hour test schedule at rated rpm and near peak power.

4.5 Oil samples are taken periodically for the measurement of viscosity, soot, oxidation, and wear metal concentrations.

⁵ Powerstroke is a trademark of the Ford Motor Company.

5. Significance and Use

5.1 *Test Method* – This test method was developed to evaluate the performance of engine oils in controlling engine valvetrain wear in turbocharged and intercooled four-cycle diesel engine, roller-style cam followers, and a ball and socket style rocker arms and running on ultra-low sulfur diesel fuel.

5.2 Use:

5.2.1 The results from this test method may be compared against engine oil specification requirements such as Specification D4485 to ascertain acceptance.

5.2.2 The design of the test engine used in this test method is representative of many, but not all, diesel engines. This factor, along with the unique operating conditions, needs to be considered when comparing the test results against specification requirements.

6. Apparatus

6.1 *Laboratory*: – Observe the following laboratory conditions to ensure good control of test operations and good repeatability:

6.1.1 The ambient laboratory atmosphere shall be relatively free of dirt and other contaminants as required by good laboratory standards. Air filtration and temperature and humidity control in the engine buildup area helps prevent accumulation of dirt, rust, and other contaminants on engine parts and aids in measuring and selecting parts for assembly.

6.2 Test Engine:

6.2.1 The test engine is a MY 2019 Ford Powerstroke⁵ diesel engine with a displacement of 6.7L. It features no aftertreatment and is an electronically controlled, turbocharged, charge air-cooled, eight-cylinder, direct- injection, compression ignition engine with an in-block camshaft, dual push tube per cam-follower, and a four valve per cylinder arrangement.

6.2.2 *Ford Motor Company Parts and Part Numbers* – Information about test parts and part numbers is provided in [Annex A3](#). Use test parts on a first-in/first-out basis. Procure engine parts from Ford Motor Company⁶ or the Central Parts Distributer (CPD). Part numbers indicated in this procedure are valid at the time of initial publication and may be superseded by Ford over the life of the test method. Supersession numbers must be provided by a Ford Dealership and approved by Ford engineering staff prior to use. A list of appropriate superseded numbers may be obtained from the TMC website.

6.2.2.1 *Critical Test Parts* – Procure critical test parts from the Central Parts Distributer (CPD). Critical test parts are listed in [Annex A3](#).

6.2.2.2 *Replaced Parts* - Replace all parts provided in [Annex A3](#) with new parts every test.

6.2.2.3 *Reusable Parts* – Parts shown in [Annex A3](#) may be used multiple tests as long as they remain serviceable and are cleaned if they come in contact with oil.

6.2.2.4 *Engine Control Module (ECM)* – Run the engine with an ECM (P/N: HC3A-12B684-BA2 and HC3A-12A650-BA2UEX) that utilizes calibration DFDDOI1B59_2017_Dyno_450. Calibration can be obtained by contacting and supplying an ECM to the Ford Motor Company⁶.

6.2.2.5 *Test Stand Hoses and Lines* – Dimensions given for various line internal diameters should be treated as a nominal target for line sizes. It is understood that various manufactures and batches of line/hose will have slight variations in ID. The line size closest to the specified ID should be used.

6.3 Test Stand:

6.3.1 Engine Mounting:

6.3.1.1 *Mounting Angle* - Mount the engine at a 5° +/- 0.5° from vertical measured from the rear surface of the flywheel housing with the front higher than the rear. The engine is to be level from left and right.

6.3.1.2 *Front Mounts* – Construct front mounts for the engine to maintain an engine mounting angle in accordance with [6.3.1.1](#). An example of typical front mount setup using the engine's two side mounts is shown in [Figure A4.2](#) and [Figure A4.3](#).

6.3.1.2.1 *Left Front Mount* – Use production Engine Support Insulator Assembly P/N HC3Z-6038-F and Engine Support Bracket P/N HC3Z-6031-A. Connect Support Insulator Assembly to a test stand mount, and securely affix the test stand mount to the test bed.

6.3.1.2.2 *Right Front Mount* – Use production Engine Support Assembly P/N HC3Z-6038-C and Engine Support Bracket P/N HC3Z-6030-B. Connect Support Insulator Assembly to a test stand mount, and securely affix the test stand mount to the test bed.

6.3.1.3 *Rear Mounts* – Construct rear mounts for the engine to maintain an engine mounting angle in accordance with [6.3.1.1](#). An example of a typical rear mount setup is shown in [Figure A4.1](#).

⁶ Ford Motor Company Service Product Development, SEO Suite 200 Room P030, 17225 Federal Drive, Allen Park, MI 48101.

6.3.1.3.1 Manufacture a flywheel housing and attach to rear of engine. The flywheel housing is not specified but a typical design is shown on part drawing in [Figure A4.4](#).

6.3.1.3.2 Manufacture other components to mate with the flywheel housing and mount the engine on the test bed. These components are not defined by this test procedure outside of they shall contain Lord⁷ CB-1124-5 center bonded rubber mounts (2 per side of engine, left and right) to isolate vibrations between the engine and test bed and shall not interfere with the driveline defined in [6.3.2](#).

6.3.2 Driveline:

6.3.2.1 *Flywheel* – Manufacture flywheel to print in [Figure A4.5](#). Secure manufactured flywheel to crankshaft using eight bolts. Torque bolts to 100 Nm. Carbon Tool & Manufacturing⁸ has been found as a suitable supplier for manufacturing the flywheel.

6.3.2.2 *Rubber Coupling* - Connect flywheel from [6.3.2.1](#) to Reich⁹ Coupling A0220025.

6.3.2.3 *Driveshaft* – The exact driveshaft needed is not specified by this procedure. Driveshaft shall have a minimum stiffness of 150 kN/Rad, prevent excessive speed or torque fluctuations, and be capable of controlling engine speed to the set points in [Table 1](#). A Machine Services Inc. MSI-63555/71-22 driveshaft¹⁰ has been found suitable for this purpose. The driveshaft shall be mounted in the vertical plane at a $2.5^\circ \pm 0.5^\circ$ angle from the horizontal, with end connected to the Reich Coupler from [6.3.2.2](#) higher than the end connected to the dynamometer.

6.3.2.4 *Dynamometer* – Use a dynamometer capable of controlling engine speed to the set points in [Table 1](#). A Midwest 1519 dynamometer¹¹ has been found suitable for this purpose.

6.3.3 Electronics:

6.3.3.1 *Chassis Harness Modification*: The chassis wire harness can be modified to remove unused connectors. [Figure A4.6](#) lists the unused connectors.

6.3.3.2 *ECM Power*: The ECM power shall be supplied from a nominal 12 Vdc power supply that does not interrupt/interfere with proper ECM operation. Connect the power supply to pins 4 and 18 in the 22-pin ignition panel connector in [Figure A4.6](#).

6.3.3.3 *Ignition*: The ignition power shall be supplied to pins 2, 5, and 17 of the ignition panel connector (See [Figure A4.6](#)) with a nominal 12 Vdc of switched power.

6.3.3.4 *Accelerator Pedal Signal* – Simulate the accelerator pedal signals with the DAQ system, (See [Table 2](#)) for specifications. Apply signals to the accelerator pedal connector in [Figure A4.6B](#).

6.3.3.5 *Engine Grounding* – Ground the engine and the negative terminal of the power source to a common ground.

6.3.3.6 *CAN Data Acquisition* – Record CAN data from pins 6 and 14 of OBD-II connector on the chassis wire harness, (See [Figure A4.6](#)). Protocol and equipment for reading and recording CAN data is not specified by this procedure.

6.3.3.6.1 Wire harness wires may either be spliced into or the use of the standard OBD-II connector may be employed for reading the CAN signals.

6.3.4 Primary Coolant System:

6.3.4.1 To prevent air entrainment and to control primary coolant system related parameters within specified limits, use a closed-loop, pressurized, external, engine-cooling system. These are typically composed of a heat exchanger, expansion tank, sight glass, and flow meter.

6.3.4.2 *Primary Coolant System Configuration*– Configure primary coolant system to the schematic shown in [Figure A4.7](#). Coolant line ID shall not be smaller than the engine inlet or outlet ports

6.3.4.2.1 *Thermostat* – Block both sides of the thermostat fully open (typically 8 mm) as shown in [Figure A4.8](#).

6.3.4.2.2 *Engine-Coolant Outlet Temperature Control* – To control the Engine-Coolant Outlet Temperature, modulate the flow of the cooling medium through the heat exchanger used to cool the primary engine coolant system coolant or modulate the amount of primary engine coolant system coolant that flows through the heat exchanger using a three-way valve and bypass around the heat exchanger.

6.3.4.2.3 *Primary Coolant System Expansion Tank* – Fit the primary coolant expansion tank with a radiator cap to maintain pressure in the coolant system during test operation. A radiator cap with pressure rating of 138 kPa has been found suitable.

6.3.4.2.3.1 Pressurize the system above the coolant level in the expansion tank to control the Air Pressure in Engine Coolant System to the specified setpoint in [Table 1](#).

6.3.4.2.4 *EGR Coolant Configuration* – The test does not use the factory EGR Cooler. As such, remove the EGR Cooler Inlet tube that comes off the Engine Cooling Crossover pipe and block off the port as shown in [Figure A4.9](#).

⁷ Lord, 111 Lord Dr., Cary, NC 27511, USA. Tel +1 877-275-5673.

⁸ Carbon Tool & Manufacturing, Inc. 12735 Inkster Rd. Livonia, MI 48150, USA. Tel +1-734-422-0380.

⁹ The sole source of supply of the apparatus known to the committee at this time as Reich USA Corporation, 300 Route 17 South Suite H Mahwah, NJ 07430, USA. Tel +1 201-684-9400.

¹⁰ A source of supply of the apparatus known to the committee at this time as Machine Services Inc., 1000 Ashaubenon St., Green Bay, WI 54304, USA. Tel:+1 800-677-8711.

¹¹ A source of supply of the apparatus known to the committee at this time Dyne Systems, Inc., W209 N17391 Industrial Drive, Jackson, WI 53037, USA. Tel.:+1 800 657 0726.

6.3.4.3 Cooling System Modifications:

6.3.4.3.1 *Production Oil Cooler* – The production oil cooler is not used for the test. As such, block off the oil cooler coolant feed on the side of the engine block and the return line on the low-pressure side of the water pump as shown in [Figure A4.13](#).

6.3.4.3.2 *Production Expansion Tank* – The production expansion tank is not used in this test procedure. Cap the feed for the expansion tank on the low-pressure side of the water pump as shown in [Figure A4.10](#).

6.3.4.3.3 *Engine Coolant Temperature Sensor Modifications* – Modify the wire harness connecting the engine’s coolant temperature sensor with the ECM to allow for a false coolant temperature signal to be read by the ECM to control soot generation. See [Figure A4.6C](#) for connector pin identification.

6.3.4.3.3.1 Use a power source to supply a voltage between 0.6 and 3.45 volts. A voltage above 3.45 V results in a change in the engine map that is not permissible to run on.

6.3.4.3.3.2 Supplying a false coolant temperature signal should only be done during the test phase. All other engine operation shall be run with the ECM reading the actual coolant temperature sensor (i.e., break-in and flush sequences).

6.3.4.3.3.3 It is recommended to also incorporate a switch to allow the ECM to either read the false signal or the actual signal from the coolant temperature sensor.

6.3.4.4 *Primary Coolant System Coolant* - For each test, use new Motorcraft Yellow Coolant (See [7.3](#)) to limit scaling in the cooling system.

6.3.5 Secondary Coolant System:

6.3.5.1 To prevent air entrainment and to control secondary coolant system related parameters within specified limits use a closed-loop, pressurized, and external system composed of the production Charge Air Cooler P/N BC3Z-6K775-B, Expansion Tank, and Heat Exchanger. The schematic for a typical system is shown in [Figure A4.11](#).

6.3.5.2 *Air Temperature at CAC Outlet Control* – To control Air Temperature at CAC Outlet, modulate the flow of cooling medium used to cool the secondary coolant system coolant or modulate the amount of secondary coolant system coolant that flows through the heat exchanger using a three-way valve and bypass around the heat exchanger, or other appropriate good engineering practice CAC cooling control process.

6.3.5.3 *Secondary Coolant System Expansion Tank* - Fit the secondary coolant expansion tank with a radiator cap with a recommended pressure minimum of 70 kPa.

6.3.5.3.1 Pressurize the system above the coolant level at the expansion tank to control Air Pressure in CAC Coolant System to the specified setpoint in [Table 1](#).

6.3.5.4 *Secondary Coolant System Coolant* - For each test, use Motorcraft Yellow Coolant (See [7.3](#)).

6.3.6 *Front End Accessory Drive* – Use a short front end accessory drive belt with an effective length of 1619 mm that only connects the driveshaft, primary water pump, secondary water pump, and tensioner pulleys, as shown in [Figure A4.12](#). A Gates Micro-V P/N: K080635 has been found suitable for this purpose.

6.3.7 Oil-Cooling System:

6.3.7.1 This test uses an oil cooler relocation plate in place of the production oil cooler to pass oil through the remote oil heat exchanger. Copper containing materials shall not be used in any components or piping that encounters the oil. An example setup is shown in [Figure A4.13](#).

6.3.7.2 *Oil Cooler By-Pass Modification* – Remove the factory Oil Cooler By-Pass soft plug in the upper oil pan. Replace with an Oil Cooler By-Pass soft plug P/N: BC3Z- 6026-B that has had the center hole welded closed or a 1-1/8 in. diameter soft plug. Ensure care when welding and installing as to not deform the soft plug, which could allow oil to by-pass the heat exchanger. See [Figure A4.17](#).

6.3.7.3 *Oil Cooler Relocation Plate* – Attach a Maryland Performance Diesel¹² MPD-67-OCPlate in place of the production oil cooler to direct oil through the Remote Oil Heat Exchanger.

6.3.7.4 *Remote Oil Heat Exchanger* – Use a Standard Xchange 127 mm × 356 mm double-pass, stainless-steel, remote oil heat exchanger¹³ (P/N: SN516005014002).

6.3.7.4.1 Oil shall flow through the shell portion of the heat exchanger in a single pass.

6.3.7.4.2 Use process water or other cooling medium through the tube side of the heat exchanger.

6.3.7.4.3 Control oil temperature by a valve on the cooling medium line to control the flow of cooling medium to meet Oil Temperature In Engine Gallery setpoints in [Table 1](#).

6.3.7.5 *Oil Lines* – Use nominally 13 mm ID lines to connect the Remote Oil Heat Exchanger in [6.3.7.4](#) to the Oil Cooler Adapter [6.3.7.2](#).

6.3.7.5.1 Oil Supply and Return line lengths (including all fittings) from the Oil Cooler Adapter Relocation Plate to the Remote Oil

¹² The sole source of supply of the apparatus known to the committee at this time as Maryland Performance Diesel, 5199 Raynor Ave, Linthicum Heights, MD 21090, USA. Tel: +1 410-354-0340.

¹³ The sole source supply of the apparatus known to the committee at this time as Standard Xchange.

Heat Exchanger and back shall be 2000 ± 60 mm. See [Figure A4.13](#).

6.3.7.6 *Oil Sampling Port* – Locate an oil sampling port on the Oil Supply line from [6.3.7.5.1](#). Tee sample line off Supply line and use a small petcock valve (or similar), as shown in [Figure A4.13](#). Use a maximum sample line length of 1500 mm and maximum line ID of 6 mm.

6.3.7.7 *Oil Charging Port* – Locate an oil charging port on the Oil Return line from [6.3.7.5.2](#). Tee charging port from Return line and cap port during test operation as shown in [Figure A4.13](#). It is recommended to use a ball valve in addition to a cap for the oil charging port.

6.3.7.8 *Remote Mount Oil Filter Block Setup* – Remove the factory installed oil filter head and install the custom remote oil filter adapter plate shown in [Figure A4.30](#). Assemble and install the dual remote oil filter system¹⁴ as shown, using the components outlined in [Figure A4.31](#). The oil supply and return lines from the engine mounted oil filter adapter to the dual filter head setup shall be plumbed using type, AN-12 Stainless Braided Teflon Core hose with AN-12 Stainless Fittings. Total line length including fittings shall be less than 910 ± 20 mm.

6.3.7.8.1 Use new Ford oil filters part number FL-2051S for each flush and test. 6.3.7.9 *Engine Oil Temperature Sensor* – Place a nominally 12 k Ω resistor in place of the oil temperature sensor (between power and signal wires).

6.3.8 *Auxiliary Oil System:*

6.3.8.1 To maintain a constant oil level in the engine oil pan, connect it to a separate, closed reservoir suspended from a load cell with a minimum capacity of 4L. Circulate oil through the reservoir with an auxiliary pump (See [6.3.8.5](#)). Use lines with 10 mm ID for the return to the engine oil pan. Use lines with 13 mm ID for the suction from the engine oil pan. The system schematic is shown in [Figure A4.14](#). Connect the oil fill cap to a vent line at the top of the closed reservoir with a minimum ID of 5 mm, as shown in [Figure A4.32](#). The vent line shall connect above the oil level in the auxiliary oil reservoir.

6.3.8.2 Locate the suction line of the auxiliary oil-system in the bottom of the lower oil pan at a distance of 30 ± 5 mm from the front edge of the gasket flange of the pan and 120 ± 10 mm from left edge of gasket flange (when viewing the lower oil pan upside down). The suction tube attached to the suction line shall protrude into the bottom of the oil pan at a distance of 100 ± 1 mm from the top of the suction tube to inside bottom of the lower oil pan, as shown in [Figure A4.15](#). Modify the lower oil pan by: Refer to [Figure A4.16](#) for Oil Pan Weldment Modifications.

- (1) Drill a $\frac{1}{2}$ in hole in the bottom of the oil pan at 120 ± 10 mm from the left edge of the gasket flange (when upside down) of the oil pan and 30 ± 5 mm from the front edge of the gasket flange of the oil pan, as shown in [Figure A4.16](#).
- (2) Weld a $\frac{1}{2}$ in pipe coupling to the lower oil pan over the hole from (1) as shown in [Figure A4.16](#).
- (3) Reinforcement of the pan can be made on the external surface as needed to avoid cracking or failure of the coupling weld.
- (4) Machine a $\frac{1}{2}$ " OD tube to desired length.
- (5) Insert tube from (4) through pipe coupling from (2) and use a compression fitting to set the suction tube height in the pan. See [Figures A4.14 and A4.15](#).
- (6) Connect $\frac{1}{2}$ " tube to auxiliary oil suction line.

6.3.8.2.1 Suction line length to the auxiliary oil reservoir from the end of the supply pickup tube in the oil pan to the top of the auxiliary oil reservoir shall be 2970 ± 150 mm (including all fittings and the in-line Viking external pump).

6.3.8.3 Locate the return line of the auxiliary oil-system on the rear of the lower oil pan, as shown in [Figure A4.16](#). Modify the lower oil pan by:

- (1) Drill a $\frac{3}{8}$ " in hole in the rear of the lower oil pan at the position shown in [Figure A4.16](#).
- (2) Weld a $\frac{3}{8}$ " NPT pipe coupling to the previously machined hole in the rear of the lower oil pan.
- (3) Reinforcement of the pan can be made on the external surface as needed.

6.3.8.3.1 Return line length from the bottom of auxiliary oil reservoir to the return line machined fitting in the rear of the lower oil pan shall be 2130 ± 150 mm (including all fittings and the in-line Viking external pump).

6.3.8.4 Locate an oil drain and drain valve at the bottom of the oil pan. Modify the lower oil pan by:

- (1) Drill a $\frac{1}{2}$ " hole in the bottom of the oil pan as shown in [Figure A4.16](#).
- (2) Reinforce the external surface of the pan as needed and weld a $\frac{1}{2}$ " pipe coupling to the bottom of the oil pan. Connect an appropriately sized ball valve to a $\frac{1}{2}$ " NPT male fitting.

6.3.8.5 Use Viking Pump Model SG041825 as the auxiliary oil pumps. Nominal pump speed is specified as 1140 r/min.

6.3.9 *Crankcase Ventilation System* – This engine utilizes an open crankcase ventilation system. The production closed system is not used for testing. Use good engineering practice to build a system to manage up to 10kPa blow-by pressure.

6.3.9.1 *Crankcase Ventilation System Surge Tank and J-Tec Meter* – Configure an external blow-by system surge tank and J-Tec Meter according to [Figure A4.36](#). The recommended minimum surge tank volume is 19 liters.

6.3.9.1.2 No connections are allowed on the blow-by outlet side of the J-Tec Meter. Keep all lab ventilation devices far enough

¹⁴ The sole source of supply for Item#1 WGS Remote Filter Head (see table inset in Fig. A4.31) is W. G. Sourcing, Inc., 413 Grayson Dr. Winder, GA. 30680 www.wgsourcing.net.

away from the outlet side of the J-Tec Meter so there is not a vacuum draw on the meter outlet. Labs shall perform in-house maintenance and cleaning of the system between each test.

6.3.9.2 Oil Mist Separator Hose – Remove the production Oil Mist Separator hose and block the port where the production hose connects to the lower intake before the turbo charger inlet. See [Figure A4.37](#) Either thread and block the production connector using a pipe plug or remove the tube from the lower intake and replace with an appropriately sized welch plug.

6.3.10 Air Supply and Filtration System:

6.3.10.1 Modify the inlet of the production air box to accept the laboratory's processed induction air supply. See [Figure A4.38](#). Filtered air should be supplied to the engine either via the production air filter, Motorcraft FA-1902 or a facility filtration system. If using a facility filtration system, the filter paper may be removed from the production air filter element leaving the seal and mesh screen as the sealing element for the air box as shown in [Figure A4.39](#).

6.3.10.2 Remove the external foam air filter element and seal the alternate air box inlet where the foam air filter element would normally reside. See [Figures A4.40 and A4.41](#).

6.3.10.3 Air Supply Pressure Control – Install a control system in the engine's air system prior to the engine air box to control the Air Pressure in Engine Intake to the set points in [Table 1](#).

6.3.10.4 Specifications for CAC – Use a new production Charge Air Cooler for each test. (See [6.2.2.2](#))

6.3.11 Fuel System:

6.3.11.1 Fuel Supply Pressure – Use an external fuel pump to supply a minimum Fuel Pressure at Engine Inlet of 280 kPa. Ford Part BC3Z-9G282-E has been found suitable for this. Also, feed the engine with fuel from a day tank that mixes return fuel from the engine with make-up fuel from a fuel storage tank. A typical fuel system schematic is shown in [Figure A4.18](#).

6.3.11.2 Fuel Temperature Control – Heating, cooling, or both of the fuel supply and return may be required to achieve adequate fuel-temperature control with the set points specified in [Table 1](#).

6.3.12 Engine Exhaust System:

6.3.12.1 Connect the turbo outlet-elbow to the factory downpipe (BC3Z-6N646-A). The factory downpipe shall not be modified to connect with the test cell exhaust system until after Exhaust Temperature in Tailpipe pressure tap (See [8.3.2.13](#)).

6.3.12.2 Engine Exhaust Pressure Control - Install a control system in the tailpipe after any temperature or pressure measurement devices to adequately control Exhaust Back Pressure in Tailpipe to set points in [Table 1](#).

6.3.12.3 EGR Block-Off – The engine in this test does not use the factory EGR cooler so ports for EGR on the right exhaust manifold and intake manifold along with the right cylinder head need to be blocked off. 6.3.12.3.1 Do not use factory EGR cooler on engine.

6.3.12.3.2 Block-off the EGR port on the right exhaust manifold, as shown in [Figure A4.9](#).

6.3.12.3.3 Block-off the EGR port on the intake manifold, as shown in [Figure A4.9](#).

6.3.12.3.4 Block-off coolant ports on the right rocker cover, as shown in [Figure A4.9](#).

6.3.12.3.5 Place a nominally 18.71 kΩ resistor in place of the EGR temperature sensor (between the power and signal wires).

6.3.12.3.6 Connect EGR Valve to wire harness connection and mount off engine in cell.

Table 1 Schedule of Conditions for the Test Procedure

	Set Point for Wear Phase
Time, h	200
Controlled Quantities, ^A units	
Engine Speed, r/min	2800
Fuel Flow Rate, kg/hr.	70.5
Air Temperature at CAC Outlet, °C	50
Engine Coolant-Outlet Temperature, °C	90.5
Air Temperature in Engine Intake, °C	25
Fuel Temperature at Engine Inlet, °C	35
Oil Temperature in Engine Gallery, °C	109
Air Pressure in Engine Intake, kPa(A)	95
Exhaust Back Pressure in Tailpipe, kPa(A)	194
Ranged Quantity	
Air Pressure in CAC Coolant System, kPa(G)	>25
Air Pressure in Engine Coolant System, kPa(G)	>120
Air Pressure at CAC Outlet, kPa(G)	>160
Uncontrolled Quantities, units	
Engine Torque, Nm	Record
Air Dewpoint Temperature at Engine Inlet, °C	Record
Air Temperature at Turbo-Compressor Outlet, °C	Record
Air Temperature of Ambient Test Cell, °C	Record
CAC Coolant-Inlet Temperature, °C	Record
CAC Coolant-Outlet Temperature, °C	Record
Engine Coolant-Inlet Temperature, °C	Record
Exhaust Temperature in Left Exhaust Manifold, °C	Record
Exhaust Temperature in Right Exhaust Manifold, °C	Record
Exhaust Temperature in Tailpipe, °C	Record
Fuel Temperature at Engine Outlet, °C	Record
Oil Temperature in Oil Pan, °C	Record
Air Pressure at Dewpoint Measurement Location, kPa(A)	Record
Air Pressure at Turbo-Compressor Outlet, kPa(G)	Record
Air Pressure in Engine Crankcase, kPa(G)	Record
Barometric Pressure, kPa(A)	Record
Exhaust Pressure in Left Exhaust Manifold, kPa(G)	Record
Exhaust Pressure in Right Exhaust Manifold, kPa(G)	Record
Fuel Pressure at Engine Inlet, kPa(G)	Record
Oil Pressure in Engine Gallery, kPa(G)	Record
Oil Pressure Pre-Filter, kPa(G)	Record
Oil Pressure Filter Delta, kPa(G)	Record
Engine Coolant Flow Rate, L/min	Record
Auxiliary Oil Reservoir Mass, kg	Record
Air Moisture Content at Engine Inlet, g/kg	Record
Voltage from Engine Coolant Temperature Sensor, V	Record
Fuel Injection Timing, deg. BTDC	Record

^ATarget all controlled quantities at mean.

Table 2 Accelerator Pedal Signals

Command Signal	Operating Range	Min Signal (Idle)	Max Signal (WOT)
Acc Pos Sensor 1	0.0 - 5.0 Vdc	0.808 Vdc (16 %)	3.984 Vdc (80 %)
Acc Pos Sensor 2	0.0 - 2.5 Vdc	0.404 Vdc (16 %)	1.992 Vdc (80 %)

Note: Acc Pos Sensor 2 should always be 50% of Acc Pos Sensor 1

7. Engine Fluids

7.1 *Test Oil* – Approximately 120 L of test oil is required for the test.

7.2 *Test Fuel* – Approximately 16200 L of a Surveillance Panel approved ULSD test fuel is required per test. The approved fuels for this test are PC-10 diesel test fuel and ASTM D975 fuel meeting the required fuel properties and tolerances shown in the “TMC-Monitored Test Fuel Specifications” document maintained by the TMC (See [A5](#)).

7.3 *Coolant* – Use Motorcraft Yellow 50/50 Prediluted Antifreeze/Coolant (PN: VC-13DL-G).

7.4 *Build Oil* – Use Motorcraft Super Duty Diesel Motor Oil SAE 10w-30. It is available from Ford under part number XO-10W30-DSD for a drum quantity.

7.5 *Cleaning Materials:*

7.5.1 *Degreasing Solvent*—Mineral spirits meeting the requirements of Specification D235, Type II, Class C for Aromatic Content (0 to 2) volume %, Flash Point (61°C, min) and Color (not darker than +25 on Saybolt Scale or 25 on Pt-Co Scale). (**Warning**-Combustible-Health hazard-see appropriate SDS). A Certificate of Analysis is required for each batch of solvent.

7.5.2 Heptane C₇H₁₆ is a recommended cleaning agent for final rinsing of some special test components. (**Warning** – Flammable-Health hazard-see appropriate SDS).

8. Preparation of Apparatus

8.1 *Cleaning of Parts Prior to Engine Assembly:*

8.1.1 *Reused Engine Parts* – Any hardware removed from the engine between tests that will be reused should be cleaned to eliminate oil residue contamination.

8.1.2 *Measured Test Hardware* – Prepare and clean measured test hardware in accordance with [Section 10](#).

8.2 *Engine Assembly:*

8.2.1 *Assembling the Test Engine-Preparations*—Use the long block obtained from the supplier.⁶

8.2.2 *Engine First Use* - If this is the first use of the long block or short block, it is recommended that it be disassembled, cleaned, lubricated, and rebuilt prior to test in accordance with the appropriate F-250-550 workshop manual.¹⁵

8.2.2.1 Remove cylinder heads, piston assemblies, and inspect rod and main bearings. Clean the pistons, rings, piston grooves, and cylinder bores of any factory build oil and /or any deposits or debris that may be present. Inspect accessible oil galleries and crankcase for any debris and remove or clean as necessary. Verify the piston oil cooling nozzles are aligned appropriately to clear the piston and rotating assembly. Clean and inspect the cylinder heads and re-assemble the engine using the appropriate engine assembly fluid and instructions in the F-250-550 workshop manual.

8.2.2.3 *Parts Selection*—Instructions concerning the use of new or used parts are detailed in 6.2.2.

8.2.2.4 *Sealing Compounds*—Use of a silicon-based sealer is permissible. Motorcraft TA-357 has been found suitable for use.

8.2.2.4.1 Use silicon based sealer sparingly since it can elevate the indicated silicon content of the used oil.

8.2.2.4.2 Non-silicon liquid or tape thread sealers can be used on bolts and plugs.

8.2.2.5 *Gaskets and Seals*—Install new gaskets and seals where appropriate during engine assembly.

8.2.2.6 *Block Preparations*—Inspect block, including oil galleries for debris and rust.

8.2.2.6.1 Remove any debris or rust that is found.

8.2.3 *Engine Subsequent Use* – A short block can be used for a maximum of 7 Test Starts or no more than 1000 total accumulated

¹⁵ Purchase from a local Ford Dealer

engine hours. (Note: this number includes any references).

- 8.2.3.1 *Critical Parts Installation* – Use critical parts from supplier, (See 6.2.2.1). New critical parts shall be used for each test.
- 8.2.3.2 Install new cam followers, premeasured pushrods and premeasured rocker arm fulcrum assemblies in accordance with the appropriate F-250-550 workshop manual¹⁵.
- 8.2.3.3 Follow pre-test measurement instructions in 10.1-10.2.
- 8.2.3.4 Assemble the engine using new and used parts as instructed in 6.2.2.

8.3 *Operational Measurements:*

- 8.3.1 *Calibrations* – Calibrate thermocouples, pressure gauges, and measuring equipment for speed, torque, and fuel flow prior to each reference oil test or at any time readout data indicates a need.
 - 8.3.1.1 Conduct calibrations with at least two points that bracket the normal operating range.
 - 8.3.1.2 Make these calibrations part of the laboratory record.
 - 8.3.1.3 During calibration, connect leads, hoses, and readout systems in the normally-used manner and calibrate with necessary standards.
 - 8.3.1.4 For controlled temperatures, immerse thermocouples in calibration baths. Calibrate standards with instruments traceable to the National Institute of Standards and Technology.¹⁶

8.3.2 *Temperatures:*

- 8.3.2.1 *General* – The measurement equipment is not specified. Install the sensors such that the tip is located midstream of the flow unless otherwise indicated. The accuracy and measurement of the temperature- measurement sensors and the complete measurement system shall follow the guidelines detailed in the DACA II Task Force Report.¹⁷
- 8.3.2.2 *Air Dewpoint Temperature at Engine Inlet* – Measure the dew point temperature of fresh air into the engine prior to the engine air box but after any temperature reducing or moisture adding equipment.
- 8.3.2.3 *Air Temperature at CAC Outlet* – Locate the thermocouple after the intake throttle body at 20 ± 10 mm downstream of the throttle plate at an insertion depth of 40 ± 5 mm from the exterior face of the inlet tube as shown in Figure A4.20.
- 8.3.2.4 *Air Temperature at Turbo-Compressor Outlet* – Locate the thermocouple in the compressor outlet air piping at 200 ± 25 mm from the compressor end of the pipe, as shown in Figure A4.21.
- 8.3.2.5 *Air Temperature in Engine Intake* – Locate thermocouple in the injection molding dimple in the production airbox at an insertion depth of 55 ± 5 mm from the outside face of the air box, as shown Figure A4.22.
- 8.3.2.6 *Air Temperature of Ambient Test Cell* – Locate thermocouple in a convenient, well-ventilated position that is representative of the ambient temperature of the test cell / engine bed plate. Position thermocouple away from the engine or hot accessories.
- 8.3.2.7 *CAC Coolant-Inlet Temperature* - Locate the thermocouple in the CAC coolant hose between the secondary heat exchanger and the CAC inlet. An example is shown in Figure A4.23.
- 8.3.2.8 *CAC Coolant-Outlet Temperature* – Locate the thermocouple in the CAC coolant hose between CAC outlet and the secondary expansion tank. An example is shown in Figure A4.23.
- 8.3.2.9 *Engine Coolant-Inlet Temperature* – Locate the thermocouple in the engine coolant pipe at 570 ± 25 mm from the water pump inlet, as shown in Figure A4.24.
- 8.3.2.10 *Engine Coolant-Outlet Temperature* – Locate the thermocouple in the engine coolant line at 740 ± 30 mm downstream of the thermostat housing, as shown in Figure A4.28.
- 8.3.2.11 *Exhaust Temperature in Left Exhaust Manifold* – Locate the thermocouple in the left exhaust up-pipe downstream of the pressure tap for the Exhaust Pressure in Left Exhaust Manifold. An example is shown in Figure A4.25.
- 8.3.2.12 *Exhaust Temperature in Right Exhaust Manifold* - Locate the thermocouple in the right exhaust up-pipe downstream of the pressure tap for the Exhaust Pressure in Right Exhaust Manifold. An example is shown in Figure A4.26.
- 8.3.2.13 *Exhaust Temperature in Tailpipe* – Locate the thermocouple in the exhaust piping at 355 ± 25 mm downstream of the cobra head outlet, as shown in Figure A4.27.
- 8.3.2.14 *Fuel Temperature at Engine Inlet* - Locate the thermocouple in the engine fuel supply line at 660 ± 25 mm upstream of the flat face of the fuel filter housing, as shown in Figure A4.29.
- 8.3.2.15 *Fuel Temperature at Engine Outlet* – Locate the thermocouple in the engine return line at 610 ± 13 mm downstream of the fuel return rail, as shown in Figure A4.29.
- 8.3.2.16 *Oil Temperature in Engine Gallery* – Locate the thermocouple on the remote mounted dual oil filter assembly on the return side downstream of both primary and secondary oil filters as shown in Figure A4.30.
- 8.3.2.17 *Oil Temperature in Oil Pan* – Locate the thermocouple in the oil drain plug at an insertion depth 70 ± 2 mm from the

¹⁶ National Institute of Standards and Technology, 100 Bureau Drive, Stop 2300, Gaithersburg, MD 20899-2300, USA. www.nist.gov.

¹⁷ Available from the ASTM Test Monitoring Center, 203 Armstrong Drive, Freeport, PA. 16229, Attention: Administrator.

interior face of the oil pan, as shown in [Figure A4.16](#).

8.3.2.18 *Additional Temperatures* – Monitor any additional temperatures at lab discretion.

8.3.3 *Pressures:*

8.3.3.1 The measurement equipment is not specified. The accuracy and measurement of the pressure-measurement sensors and the complete measurement system shall follow the guidelines detailed in the DACA II Task Force Report²⁰.

8.3.3.2 *Air Pressure at CAC Outlet* - Locate the pressure pickup in the same tap after the intake throttle body as the Air Temperature at CAC Outlet thermocouple (See [8.3.2.3](#)). Use a tee fitting as shown in [Figure A4.20](#).

8.3.3.3 *Air Pressure at Dewpoint Measurement Location* – Locate a pressure tap in the intake air tubing within 300 mm of the Air Dewpoint Temperature at Engine Inlet in [8.3.2.2](#).

8.3.3.4 *Air Pressure at Turbo-Compressor Outlet* - Locate the pressure tap in a tee with the temperature measurement, as shown in [Figure A4.21](#).

8.3.3.5 *Air Pressure in CAC Coolant System* – Locate the pressure tap near the top of the secondary coolant system expansion tank above the coolant level.

8.3.3.6 *Air Pressure in Engine Coolant System* – Locate the pressure tap near the top of the primary coolant system expansion tank above the coolant level.

8.3.3.7 *Air Pressure in Engine Crankcase* – Measure crankcase pressure from the modified oil fill cap, as shown in [Figure A4.32](#).

8.3.3.8 *Air Pressure in Engine Intake* – Measure air pressure from the air bleed fitting in the air box, as shown in [Figure A4.22](#).

8.3.3.9 *Barometric Pressure* – Measure the air pressure in a convenient, well-ventilated position near the engine that is representative of the ambient pressure around any differential pressure transducers.

8.3.3.10 *Exhaust Pressure in Left Exhaust Manifold* – Locate the pressure tap in the left exhaust up-pipe upstream of the Exhaust Temperature in Left Exhaust Manifold Thermocouple. An example is shown in [Figure A4.25](#).

8.3.3.11 *Exhaust Pressure in Right Exhaust Manifold* – Locate the pressure tap in the right exhaust up-pipe upstream of the Exhaust Temperature in Right Exhaust Manifold Thermocouple. An example is shown in [Figure A4.26](#).

8.3.3.12 *Exhaust Pressure in Tailpipe* – Locate the pressure tap in the exhaust piping at 100 ± 25 mm downstream of the cobra-head outlet as shown in [Figure A4.27](#). The pressure tap shall be placed from the vertical plane at $0^\circ \pm 10^\circ$ arc around the circumference of the exhaust downpipe on the upper portion of the pipe.

8.3.3.13 *Fuel Pressure at Engine Inlet* – Locate the pressure tap in the engine fuel supply line at 660 ± 25 mm upstream of the flat face of the fuel filter housing, as shown in [Figure A4.29](#).

8.3.3.14 *Oil Pressure in Engine Gallery* -Measure the oil pressure on the outlet side of the oil filters on the remote mounted dual oil filter assembly as shown in [Figure A4.30](#).

8.3.3.15 *Oil Pressure Pre-Filter* – Measure the oil pressure on inlet side of the oil filters on the remote mounted dual oil filter assembly as shown in [Figure A4.30](#).

8.3.3.16 *Oil Pressure Filter Delta* – Calculate as Oil Pressure Pre-Filter minus Oil Pressure in Engine Gallery.

8.3.3.17 *Additional Pressures* – Monitor any additional pressures at lab discretion.

8.3.4 *Flows:*

8.3.4.1 The measurement equipment is not specified. The accuracy and measurement of the flow-measurement sensors and the complete measurement system shall follow the guidelines detailed in the DACA II Task Force Report²⁰.

8.3.4.2 *Engine Coolant Flow Rate* – Locate the flowmeter measurement device prior to the water pump inlet and after all coolant return sources have been recombined, as shown in [Figure A4.7](#).

8.3.4.3 *Fuel Flow Rate* – Locate the metering instrument in the make-up fuel stream prior to any day tank or fuel return so that only make-up or consumed fuel is measured.

8.3.5 *Miscellaneous:*

8.3.5.1 The measurement equipment is not specified. The accuracy and measurement of the miscellaneous sensors and the complete measurement system shall follow the guidelines detailed in the DACA II Task Force Report²⁰.

8.3.5.2 *Engine Speed* – Measure using an encoder, mag pickup or similar. The use of CAN data for QI calculations is not permissible.

8.3.5.3 *Torque* – Measure engine torque with an appropriately sized measurement device.

8.3.5.4 *Auxiliary Oil Reservoir Mass* –Weigh the external oil tank to measure the mass of oil in the auxiliary oil reservoir. An example is shown in [Figure A4.33](#).

8.3.5.5 *Air Moisture Content at Engine Inlet* – First, calculate the Partial Pressure of Water using Eq. (1). Then use the calculated Partial Pressure of Water to calculate the Air Moisture Content at Engine Inlet using Eq. (2):

$$P_W = \frac{10^{23.5518 + \frac{-2937.4}{D+273} * (D+273)^{-4.9283}}}{10} \quad \text{Eq. (1)}$$

$$W = 621.98 * \frac{P_W}{P_A - P_W} \quad \text{Eq. (2)}$$

Where:

- D = Air Dewpoint Temperature at Engine Inlet, °C (See 8.3.2.2).
- P_A = Air Pressure at Dewpoint Measurement Location, kPaA (See 8.3.3.3).
- P_W = Partial Pressure of Water, kPa.
- W = Air Moisture Content at Engine Inlet, g/kg.

8.3.5.6 *Accelerator Position Sensor* – Refer to Figure A4.6B and Table 2 for Accelerator Pedal position sensor connections.

8.3.5.7 *System Time Responses* –The maximum allowable system time responses for all measured quantities are shown in Table 3. Determine system time responses in accordance with the DACA II Task Force Report²⁰.

Table 3 Maximum Allowable System Time Responses

Measurement Type	Time Response, s
Speed	1.0
Torque	1.0
Temperature	3.0
Pressure	3.0
Flow Rate	4.5

8.3.6 CAN Data:

8.3.6.1 Record ECM data from the CAN bus as specified in 6.3.3.7. A list of recommended measured quantities is shown in Table 4. A minimum of the following quantities shall be measured and reported:

8.3.6.2 *Voltage from Engine Coolant Temperature Sensor* – Record from Engine Coolant 1 Sensor Voltage in accordance with Table 4.

8.3.6.3 *Fuel Injection Timing* – Record from Fuel Injection Timing in accordance with Table 4.

8.3.6.4 If a CAN bus signal integrity issue occurs during a test, engineering judgement may be used to remove the erroneous CAN data for the reporting process.

Table 4: Recommended CAN Recorded Quantities

PID Number (Hex)	Parameter Number	Quantity	Size (Bits)	Resolution	Offset	Minimum	Maximum	Units
F487	9	Intake Manifold Absolute Pressure	16	0.03125	0	0	2047	kPa
033D	0	Mass Air Flow (MAF) Sensor Frequency	16	0.25	0	0	16383.75	Hz
03C2	0	Fuel Volume Control Valve Duty Cycle	8	0.392157	0	0	100	%
03C3	0	Fuel Pressure Relief Control Valve Duty Cycle	8	0.392157	0	0	100	%
051C	0	Air Charge Temperature	8	1	-40	-40	215	°C
F404	0	Calculated LOAD Value	8	0.392157	0	0	100	%
F40C	0	Engine RPM	16	0.25	0	0	16383.75	Rpm
F433	0	Barometric Pressure	8	1	0	0	255	kPa
F442	0	Control module voltage	16	0.001	0	0	65.535	V
F449	0	Accelerator Pedal Position D	8	0.392157	0	0	100	%
F44A	0	Accelerator Pedal Position E	8	0.392157	0	0	100	%
F45C	0	Engine Oil Temperature	8	1	-40	-40	215	°C
F45D	0	Fuel Injection Timing	16	0.007813	-210	-210	301.9922	°(angle)
F45E	0	Engine Fuel Rate	16	0.05	0	0	3276.75	l/h
F469	9	Commanded EGR A Duty Cycle/Position	8	0.392157	0	0	100	%
D137	0	Number of Continuous DTCs with Pending or Confirmed Status	8	1	0	0	255	Undefined
F46D	9	Commanded Fuel Rail Pressure A	16	10	0	0	655350	kPa
F46D	10	Fuel Rail Pressure A	16	10	0	0	655350	kPa
F471	10	Variable Geometry Turbo A Position	8	0.392157	0	0	100	%
F46D	11	Fuel Rail Temperature A	8	1	-40	-40	215	°C
033F	0	Fuel Rail Temperature Sensor Voltage	16	0.000977	0	0	63.99902	V
0357	0	Engine Coolant Temperature Sensor Voltage	16	0.004888	0	0	320.3079	V
F467	9	Engine Coolant Temperature 1	8	1	-40	-40	215	°C
F473	9	Exhaust Pressure Bank 1	16	0.01	0	0	655.35	kPa

9. Procedure

9.1 *General* – The test starts with a sequence involving a flush, break-in, power check, and two (2) more flushes. The test oil is then installed, and the test procedure is initiated. The test schedule is 200 hours of running to induce valvetrain wear. Valvetrain wear is measured from an analysis of test parts after the End of Test (EOT).

9.1.1 *Soot Requirements* – All tests shall meet the following soot levels;

9.1.1.2 *100 hours* – 3.00% ± 0.50%

9.1.1.3 *200 Hours* – 6.00% ± 0.50%

9.2 Pretest Procedure:

9.2.1 First Flush:

9.2.1.1 *First Oil-Fill* – Install new oil filters, see Annex A3 for part number, and use a clean external pump (not specified by this procedure) to charge the engine with 14.5 kg of test oil through the oil charging port (See 6.3.7.7).

9.2.1.2 *Engine Start-up* – For the first start-up with new test parts, start the engine and follow flush sequence in Table A6.1.

9.2.1.3 Following the flush sequence, return to idle and stop the engine and drain the oil for a minimum of 30 minutes from the pan, remote oil heat exchanger, and external weight tank.

9.2.1.4 *Compression and Leakdown Check* – (Optional Investigative Operation) Perform a compression and leakdown check on each cylinder through the glow plug port.

9.2.1.4.1 *Compression* – If any cylinder compression is not above 2068 kPa (300 psi) and/or a cylinder has a compression of more than $\pm 20.0\%$ of the engine average (See Eq. 3 for calculation), investigate and resolve the cause of low or variant compression prior to proceeding to 9.2.2.

$$dC_i = \frac{\text{abs}(C_i - C_A)}{C_A} \times 100 \quad \text{Eq. (3)}$$

Where:

dC_i = Relative absolute difference in compression of cylinder i from the engine average, % .

$\text{abs}()$ = Absolute Value

C_i = Compression of cylinder i , kPa.

C_A = Average Compression of all eight cylinders, kPa.

i = Cylinder number.

9.2.1.4.2 *Leakdown* – (Optional Investigative Operation) If any cylinder leakdown rate is $> 20\%$ of the engine average, investigate and resolve the cause of the high leakdown rate prior to proceeding to 9.2.2.

9.2.2 *Break-in:*

9.2.2.1 *Second Oil-Fill* - Install new oil filters, see Annex A3 for part number, and use a clean or the same external pump as used in the *First Oil Fill* (not specified by this procedure) to charge the engine with 14.5 kg of test oil through the oil charging port (See 6.3.7.7).

9.2.2.2 *Engine Start-up* – For the second start-up, start the engine and follow the 7.1 h break-in sequence outlined in Table A6.2.

9.2.2.3 Carry out any unscheduled shutdowns and subsequent restarts during the break-in as described in 9.4.2.3 and 9.4.2.4, respectively.

9.2.2.4 Following any shutdowns that occur in the break-in, run the remainder of the 7.1 h break-in before proceeding to 9.2.2.5.

9.2.2.5 Upon completion of the break-in, proceed directly into the Power Check in section 9.2.3 without shutting the engine down between the end of break-in and running the Power Check.

9.2.3 *Power Check:*

9.2.3.1 *Ramp to Power Check* – Upon completion of the Break-in run step 5 of the Power Check Startup Sequence to ramp to Power Check conditions (See Table A6.9).

9.2.3.2 *Power Check Procedure* – Run the 5 minute Power Check outlined in Table A6.10.

9.2.3.3 If a torque value above 1050 Nm is obtained, proceed to the second flush. If between 1000 and 1050 Nm, conduct an engineering review to determine if other issues exist that prevent the development of power. If the power check torque is below 1000 Nm conduct repairs as needed to obtain the appropriate power on a subsequent power check run.

9.2.3.4 Upon completion of the power check, follow the normal shutdown sequence outlined in Table A6.7.

9.2.3.5 Carry out any unscheduled shutdowns as described in section 9.4. Repeat the power check sequence outlined in Table A6.10 by first restarting the engine and following the start-up sequence in Table A6.9. An uninterrupted power check at the required power level must be completed prior to proceeding to 9.2.3.6.

9.2.3.6 Following the Power Check sequence, drain the oil for a minimum of 30 minutes from the pan, remote oil heat exchanger, and external oil weight tank.

9.2.4 *Second Flush:*

9.2.4.1 *Third Oil-Fill* – Install new oil filters, see Section A3 for part number, and use an external pump (not specified by this procedure) to charge the engine with 14.5 kg of test oil through the oil charging port (See 6.3.7.7).

9.2.4.2 *Engine Start-up* – For the second start-up, start the engine and follow flush sequence in Table A6.1.

9.2.4.3 Following the flush sequence return to idle and stop the engine and drain the oil for a minimum of 30 minutes from the pan, remote oil heat exchanger, and external weight tank.

9.2.5 *Third Flush:*

9.2.5.1 *Fourth Oil-Fill* – Install new oil filters, see Section A3 for part number, and use an external pump (not specified by this procedure) to charge the engine with 14.5 kg of test oil through the oil charging port (See 6.3.7.7).

9.2.5.2 *Engine Start-up* – For the third start-up, start the engine and follow flush sequence in Table A6.1.

9.2.5.3 Following the flush sequence return to idle and stop the engine and drain the oil for a minimum of 30 minutes from the pan, remote oil heat exchanger, and external weight tank.

9.3 Test Procedure:

9.3.1 *Oil-Fill for Test Procedure* - Install new oil filters, see [Section A3](#) for part number, and use an external pump (not specified by this procedure) to charge the engine with 14.5 kg of test oil through the oil charging port (See [6.3.7.7](#)).

9.3.2 *Engine Startup* – Start the engine and confirm there are no oil leaks

9.3.3 Test Sequence:

9.3.3.1 Ramp the engine and carry out the Wear Phase warmup sequence described in [Table A6.8](#).

9.3.3.2 Run the Wear Phase for 200 hours (See [Table 1](#) for conditions) while taking oil samples at a minimum of every 25 hours as outlined in [Table 8](#) using the oil sample procedure in [9.7](#), then perform the normal shutdown sequence outlined in [Table A6.7](#), take an oil sample (following the procedure in [9.7](#)), and stop the engine.

9.3.3.3 *Post Test Compression and Leakdown Check* – (Optional Investigative Operation) Perform a compression and leak down check on each cylinder through the glow plug port as outlined in [9.2.1.2](#).

9.3.3.4 *Engine Disassembly* – After EOT, release the cooling system pressure and drain the coolant. Drain the oil for 30 minutes from the pan, oil heat exchanger, and external weight tank. Remove the cylinder heads to remove the push rods, rocker arms, and roller followers for measurements.

9.4 Engine Shutdowns and Restarts:

9.4.1 Normal Shutdown and Restart:

9.4.1.1 *General* – A normal shutdown is one that occurs as outlined in the Break-in Tables or at the End of Test (EOT).

9.4.1.2 *Normal Shutdown Sequence* – Carry out by ramping down to step 1 conditions as shown in [Table A6.7](#), then stopping the engine by turning the ignition off.

9.4.2 Unscheduled Shutdown and Restart:

9.4.2.1 *General* – An unscheduled shutdown is any shutdown other than a normal shutdown as described in [Table A6.7](#). Although the intent of this test method is to conduct the pre- test flushes, power check, break-in, and wear phase of the test procedure without unscheduled shutdowns, unscheduled shutdowns may be initiated at the discretion of the laboratory to perform repairs or due to an emergency. Record all unscheduled shutdowns in the test notes section of the Ford VTWT Procedure, appropriate report form of the Test Report Form Package.

9.4.2.2 *Emergency/Hard Shutdown*—An emergency or hard shutdown occurs when the shutdowns using the sequence described in [Table A6.7](#) cannot be completed, such as under an alarm condition or loss of power. Emergency or hard shutdowns are considered a laboratory safety procedure and are not specified by this test method.

9.4.2.3 *Shutdown Sequence* – Carry out all non- emergency, unscheduled shutdowns in the same way as for a normal shutdown, as described in [9.4.1.2](#).

9.4.2.4 Restart after an Unscheduled Shutdown:

9.4.2.4.1 If the shutdown occurs in Steps 1-7 of the break- in outlined in [Table A6.2](#), then restart as described in [Table A6.3](#).

9.4.2.4.2 If the shutdown occurs in Steps 8-9 of the break- in outlined in [Table A6.2](#), then restart as described in [Table A6.4](#).

9.4.2.4.3 If the shutdown occurs in Steps 10-12 of the break-in outlined in [Table A6.2](#), then restart as described in [Table A6.5](#).

9.4.2.4.4 If the shutdown occurs in Steps 13-15 of the break-in outlined in [Table A6.2](#), then restart as described in [Table A6.6](#).

9.4.2.4.5 If the shutdown occurs in the wear phase, restart as for a normal shutdown (See [9.4.1.3](#)).

9.4.2.5 If the shutdown occurred during the wear phase, record the length, reason, and test time for each unscheduled shutdown on the appropriate report form.

9.4.3 Shutdown and Downtime Limits—To be considered an operationally valid test:

9.4.3.1 The number of unscheduled shutdowns shall not exceed 10.

9.4.3.2 The downtime shall not exceed 150 h, where down- time is calculated as the time, during shutdowns and warmups, between the engine leaving on-test conditions (that is, the test time at which shutdown is initiated) and returning to on-test conditions (that is, the test time at which the warmup sequence is completed).

9.4.3.3 Conduct an engineering review if either condition is exceeded.

9.5 Test Timer:

9.5.1 Start the test timer immediately after the warm-up section of the test procedure has been completed and start of test conditions have been met.

9.5.1.1 *Normal Shutdowns* – The shutdown time and the subsequent warmup do not count as test time. Therefore, stop the timer immediately at the initiation of the ramp down in [9.4.1.1](#) and restart at the end of the warmup sequence when the engine is back to test conditions.

9.5.1.2 *Unscheduled Shutdowns* – The shutdown and warmup times do not count as test time. Therefore, stop the test timer immediately at the initiation of the shutdown and restart upon the completion of the warmup sequence when the engine is back on

test conditions.

9.6 *Assessment of Operational Validity:*

- 9.6.1 Calculate and report the quality index as described in A7.1.
- 9.6.2 Calculate and report averages, minimums, maximums, and standard deviations as described in A7.2.
- 9.6.3 Determine operational validity as described in A7.3.
- 9.6.4 Perform an engineering review and report the results as described in A7.4.

9.7 *Test Oil Samples:*

- 9.7.1 Take test oil samples from the oil sample line specified in 6.3.7.6.
- 9.7.2 *Purge Sample* - Prior to obtaining each test oil sample, take a 240 mL purge.
 - 9.7.2.1 After sample completion, return the purge to the engine through the auxiliary oil reservoir.
- 9.7.3 *Oil Samples* – Take oil samples at the test hours and volumes shown in Table 8.
 - 9.7.3.1 Take the 0 h oil sample from the fresh-oil container.
 - 9.7.3.2 *Oil Addition* – Initially establish the full mark as the oil mass in the auxiliary oil reservoir after 3 hours in Wear Phase conditions. After the oil sampling, has been completed at the end of each 25 h period shown in Table 8, check the oil mass. Drain a sufficient amount of oil to obtain an oil mass that is 1.4 kg below the full mark. If the oil mass is more than 1.4 kg below the full mark, do not perform a forced drain. Add 1.4 kg of new oil to the engine except at 200 h.
- 9.7.4 No other oil additions during the test are permissible outside of those listed in Table 8.
- 9.7.5 No more than a total of 30 mL of additional samples may be pulled during the wear phase of the test.

9.8 *Fuel Samples* – Take an appropriately sized fuel sample for in-house analytical analysis from the fresh fuel supply at the test cell at Start of Test (SOT) and another sample at End of Test (EOT).

9.9 *Operational Data Acquisition:*

- 9.9.1 Record all operational quantities shown in Table 1 with automated data acquisition at a minimum frequency shown in Table 5. Recorded values shall have a minimum resolution in accordance with Table 6.
- 9.9.2 Record the operational data on the appropriate test report form.

Table 5 Automatic Data Acquisition Frequency

Test Phase/Step	Log Frequency
Warm Up	15 s
Cooldown	15 s
Flush	15 s
Power Check	1 s
Break-in	15 s
Wear Phase	60 s

Table 6 Minimum Resolution of Recorded and Calculated Quantities

Quantity	Record Data to Nearest	Quantity	Record Data to Nearest
Engine Coolant Flow Rate, L/min	1 L/m	Air Dewpoint Temperature at Engine Inlet	1 °C
Fuel Flow Rate	0.1 kg/h	Air Temperature at CAC Outlet	0.1 °C
Auxiliary Oil Reservoir Mass, kg	1 g	Air Temperature at Turbo-Compressor Outlet	1 °C
Air Pressure at CAC Outlet	1 kPa(G)	Air Temperature in Engine Intake-Outlet	0.1 °C
Air Pressure at Dewpoint Measurement Location	0.01 kPa(A)	Air Temperature of Ambient Test Cell	1 °C
Air Pressure at Turbo-Compressor Outlet	1 kPa(G)	CAC Coolant-Inlet Temperature	1 °C
Air Pressure in CAC Coolant System	0.1 kPa(G)	CAC Coolant-Outlet Temperature	1 °C
Air Pressure in Engine Coolant System	0.1 kPa(G)	Engine Coolant-Inlet Temperature	1 °C
Air Pressure in Engine Crankcase	0.1 kPa(G)	Engine Coolant-Outlet Temperature	0.1 °C
Air Pressure in Engine Intake-Outlet	0.01 kPa(A)	Exhaust Temperature in Left Exhaust Manifold	1 °C
Barometric Pressure	0.1 kPa(A)	Exhaust Temperature in Right Exhaust Manifold	1 °C
Exhaust Pressure in Left Exhaust Manifold	1 kPa(G)	Exhaust Temperature in Tailpipe	1 °C
Exhaust Pressure in Right Exhaust Manifold	1 kPa(G)	Fuel Temperature at Engine Inlet	0.1 °C
Exhaust Pressure in Tailpipe	0.1 kPa(G)	Fuel Temperature at Engine Outlet	1 °C
Fuel Pressure at Engine Inlet	1 kPa(G)	Oil Temperature in Engine Gallery	0.1 °C
Oil Pressure in Engine Gallery	1 kPa(G)	Oil Temperature in Oil Pan	1 °C
Oil Pressure Pre-Filter	1 kPa(G)	Engine Torque	1 Nm
Oil Pressure Filter Delta	1 kPa(G)	Air Moisture Content at Engine Inlet	0.1 g/kg
Engine Speed	1 r/min	Voltage from Engine Coolant Temp Sensor	0.001 V
Voltage from Accelerator Pedal Position	0.001 V	Engine Fuel Temperature Sensor	0.001 V
		Fuel Injection Timing	0.01 deg. BTDC

10. Inspection of Engine, Fuel, and Oil

10.1 Individual component locations shall be tracked for all pre- and post-test measurements. The method of tracking is left to the individual test lab and values should be reported on the appropriate test form. Position nomenclature should follow the image in [Figure A4.35](#).

10.2 Push rods:

10.2.1 Clean and weigh push rod mass pre- and post-test on the appropriate report form, report push rod mass to the nearest 0.1 mg.

10.2.1.1 *Handling* – Avoid handling push rods with bare hands.

10.2.1.2 Clean push rods by: ([Adhere to Warning Statements listed in Notes 1 and 2 for Section 10.2.1.2 steps 1 - 6](#)).

Note – 1 *Degreasing Solvent*—Mineral spirits meeting the requirements of Specification D235, Type II, Class C for Aromatic Content (0 to 2) volume %, Flash Point (61°C, min) and Color (not darker than +25 on Saybolt Scale or 25 on Pt-Co Scale). (**Warning**-Combustible-Health hazard-see appropriate SDS). A Certificate of Analysis is required for each batch of solvent.

Note – 2 *Heptane C₇H₁₆* — a recommended cleaning agent for final rinsing of some special test components. (**Warning** – Flammable-Health hazard-see appropriate SDS).

- (1) Wash with degreasing solvent and a rubber bristle brush to remove any oil or deposit from the push rods.
- (2) Run solvent through the oil hole until solvent exiting the push rod is clear.
- (3) Submerge push rods in degreasing solvent for a minimum of 25 minutes. Repeat this step with fresh degreasing solvent if degreasing solvent appears dirty after first application.
- (4) Immediately upon removal from the degreasing solvent, blow dry the push rods with dry compressed shop air. Heating push rods in solvent prior to air drying is allowed at lab discretion. Ensure push rods are dry before proceeding to next step.
- (5) Rinse using the recommended Heptane C₇H₁₆ cleaning agent through the center of the pushrods and around the areas

where the ball-end and socket-end meet the shaft to remove any residual degreasing solvent.

(6) Blow dry with dry compressed shop air.

(7) Demagnetize the pushrods before recording the mass with any commercially available laboratory type demagnetizer.

10.2.1.3 Record push rod mass using an electronic or mechanical balance with a minimum display resolution of 0.1 mg.

10.2.2 Calculate push rod mass loss as the difference between the pre-test push rod mass and the post-test push rod mass. Report results to the nearest 0.1 mg on the appropriate report form.

10.3 *Rocker Arms:*

10.3.1 Disassemble, clean and measure rocker arm mass pre- and post-test on the appropriate report form, report push rod mass to the nearest 0.1 mg.

10.3.2 *Disassembly* – Remove rocker arm from its pedestal by removing the spring clip and sliding the rocker arm out from the pedestal.

10.3.2.1 Only individual rocker arm masses should be measured. Pedestals, fulcrum balls, and spring clips are not included in the mass determinations.

10.3.2.2 *Handling* – Avoid handling rocker arms with bare hands.

10.3.2.3 Clean rocker arms by: (Adhere to Warning Statements listed in Notes 1 and 2 for Section 10.3.2.3 steps 1 - 5).

(1) Carefully remove each rocker arm from the rocker assemblies.

(2) Wash with degreasing solvent and a rubber bristle brush to remove any oil or deposit from the rocker arms.

(3) Submerge in degreasing solvent for a minimum 25 minutes. Repeat this step with fresh degreasing solvent if degreasing solvent appears dirty after first application.

(4) Immediately upon removal from the degreasing solvent, blow dry the rocker arms with dry compressed shop air. Heating rocker arms in degreasing solvent prior to air drying is allowed at lab discretion. Ensure the rocker arms are dry before proceeding to next step.

(5) Rinse with recommended Heptane C₇H₁₆ cleaning agent to remove any residual solvent.

(6) Demagnetize the rocker arms before recording the mass with any commercially available laboratory type demagnetizer.

10.3.2.4 Record individual rocker arm mass using an electronic or mechanical balance with a minimum display resolution of 0.1 mg.

10.3.2.5 After recording pre-test mass for each rocker arm, reassemble the rocker arm assemblies with the pedestals, fulcrum balls, and spring clips to be used for the test.

10.3.3 At End of Test, Calculate rocker arm mass loss as the difference between the pre-test rocker arm mass and the post-test rocker arm mass. Report results to the nearest 0.1 mg on the appropriate report form.

10.4 *Roller Followers:*

Note 3 – All post-test roller followers are disassembled, cleaned and measured to record the post-test shaft wear. Using the appropriate report form, the maximum vertical depth of the wear scar is recorded to the nearest 0.1 micron.

10.4.1 *Cleaning* – Rinse roller follower with solvent to remove any oil or debris.

10.4.2 *Shaft Reference Markings* – Etch a vertical line on the end of each shaft in line with the linear motion of the roller follower. Also etch the position in the engine on the opposite end of each shaft.

10.4.4 *Shaft Removal* – Remove the axle from the lifter body by pressing the shaft from the body.

10.4.5 *Shaft Wear Measurements* – Measure and record the shape of the wear scar using a skidless stylus type measuring device. Make the measurement with the reference line etched on the end of the roller follower shaft in a vertical position in the measuring device. Calculate the wear from the wear trace chart. Wear for a given shaft is defined as the maximum vertical depth shown on the wear trace chart. An example of a typical wear trace and wear determination is shown in [Figure A4.34](#).

10.5 *Oil Analyses* – Carry out the following tests and report the results on the appropriate report form on all the test oil samples collected in the oil sampling schedule in [Table 8](#).

10.5.1 *Kinematic Viscosity (KV)* – Measure KV at 100 °C by Test Method D445. Use the minimum viscosity for calculating the viscosity increase.

10.5.2 *Soot Concentration* – Measure mass fraction of soot as % by the TGA procedure described in [Annex A4](#) of Test Method D5967.

10.5.3 *Wear Metals Concentrations* – Determine concentrations of wear metals (iron, lead, copper, chromium, aluminum, and nickel), additive metals, silicon, and sodium by Test Method D5185.

10.5.4 *Base Number* – Measure base number by Test Method D4739.

10.5.5 *Acid Number* – Measure acid number by Test Method D664.

10.5.6 *Oxidation* – Use Fourier Transform Infrared (FTIR) to measure oxidation using peak height IR techniques¹⁸ based on Practice E168.

10.5.7 *Concentration of Diesel Fuel in Used Oil (Fuel Dilution)* – Measure the mass fraction as percent of the fuel in the oil by Test Method D3524.

10.6 *Fuel Inspections:*

10.6.1 Use inspection records provided by the fuel supplier, or analytically measured by the test lab, to ensure the fuel conforms to the specifications shown in **Table A5.1** and to complete the appropriate form for the last batch of fuel used during the test. In addition, make the following measurements on fresh fuel sample container at Start of Test (SOT) (that is, at 0 hour on the test timer) and End of Test (EOT) fuel samples.

10.6.1.1 API gravity at 15.6 °C by Test Method D287 or Test Method D4052.

10.6.1.2 Mass fraction total sulfur as mg/kg by Test Method D5453 (D2622 or D4294 can be substituted). Take an appropriately sized fuel sample for these measurements. (See 9.8)

10.7 *Oil Consumption Calculation:*

10.7.1 Using the oil mass measurements from the Auxiliary Oil Reservoir Mass (See 8.3.5.4), determine the oil consumption in grams per hour by performing a linear regression on the data. Do not use oil consumption data from the first 10 h of the test. For each of the eight 25 h periods between 0 and 200 hours, regress the 25 h periods excluding the first 4 hours. To calculate the final average oil consumption, average the eight periods from test hours 0 through 200.

10.7.1.1 Following any shutdowns, oil samples, or oil additions exclude from the regression 4 h of oil mass data to account for the stabilizing of the measurement.

10.7.1.2 If any shutdowns occur during a 25 h period, the result for the 25 h period shall be the test time weighted average of all the regression slopes that apply to that period. An example with two shutdowns, one at 71 h and one at 79.5 h is shown in **Table 7**.

10.7.1.3 Report the oil consumption for each of the eight periods and the average oil consumption across the eight periods on the appropriate report forms.

Table 7 25 h Period Oil Consumption Sample Calculation

Auxiliary Oil Reservoir Mass Data	Test Time Start, hh:mm	Test Time Stop, hh:mm	Run Time, h:mm	Regression Slope, g/h
Stabilizing	60:00	64:00	4:00	n/a
Collecting	64:00	71:00	7:00	40
Stabilizing	71:00	75:00	4:00	n/a
Collecting	75:00	79:30	4:30	45
Stabilizing	79:30	83:30	4:00	n/a
Collecting	83:30	85:00	1:30	43
Oil Consumption (60 to 85) h =				
[[(7 x 40) + (4.5 x 45) + (1.5 x 43)] / 13 = 42				

¹⁸ Mack T12 Infrared Oxidation Peak Height Measurement Procedure available from TMC.

Table 8 Minimum Requirements for Oil Sampling and Testing

Phase	Test Hour	Sample Size, mL	Perform Oil Add	Quantity/Test Method							Comments
				Fuel Dilution	KV at 100 °C	Oxidation IR Peak Height Method	Soot by TGA	Wear Metals	Base Number	Acid Number	
				D3524	D445	Based on E168	D5967	D5185	D4739	D664	
	0	120		X	X	X	X	X	X	X	From fresh oil container
Wear	25	120	X		X	X	X	X			
Wear	50	120	X	X	X	X	X	X	X	X	
Wear	75	120	X		X	X	X	X			
Wear	100	120	X	X	X	X	X	X	X	X	
Wear	125	120	X		X	X	X	X			
Wear	150	120	X	X	X	X	X	X	X	X	
Wear	175	120	X		X	X	X	X			
Wear	200	120		X	X	X	X	X	X	X	

11. Laboratory and Engine Test Stand Calibration and Non-Reference Oil Test Requirements

11.1 **Annex A8** describes calibration procedures using the TMC reference oils, including their storage and conditions of use, the conducting of tests, and the reporting of results.

11.2 **Annex A9** describes maintenance activities involving TMC reference oils, including special reference oil tests, special use of the reference oil calibration system, donated reference oil test programs, introducing new reference oils, and TMC information letters and memoranda.

11.3 **Annex A10** provides information regarding new laboratories, the role of the TMC regarding precision data, and the calibration of test stands used for non-standard tests.

11.4 *New Laboratories and New Test Stands:*

11.4.1 *General* – A new laboratory is one that has never previously calibrated a test stand for this test method. A new stand is a test cell and support hardware that has not completed an acceptable reference-oil test within 24 months of the EOT date of the last acceptable reference-oil test. Perform a calibration as described in 11.4.2 to introduce a new test stand.

11.4.2 *Test Stand Calibration:*

11.4.2.1 Calibrate the test stand by conducting a test with a blind reference oil (See **A8.2**). Submit the results to the TMC as described in **A8.6**. Determine the acceptability of a reference-oil test according to the Lubricant Test Monitoring System (LTMS).¹⁹

11.4.2.2 Calibrate a stand after 12 months or 15 operationally valid non-reference tests have elapsed since the completion of the last successful calibration test. An unsuccessful calibration test voids any current calibration on the test stand.

11.4.2.3 A non-reference test is defined as one in which the engine has been installed, charged with the test oil and the engine has been cranked with the intent of firing the engine. Report the date the engine was charged with test oil as the oil charged date on the appropriate form. Report the first time the engine is cranked with the intention of firing the engine as the engine start date on the appropriate form.

11.4.3 *Test Stand and Engine Combination* – For reference-oil and non-reference-oil tests, any engine may be used on any stand. However, use the engines on the test stands on a first available engine basis and do not attempt to match a particular test stand and engine for any given test.

11.4.4 *Stand Modification and Calibration Status* – Stand calibration status will be invalidated by conducting any non-standard test or modification of the test and control systems, or both. A non-standard test is any test conducted under a modified procedure, or using non-procedural hardware, or using controller-set-point modifications, or any combination thereof. Any such changes terminate the current calibration period. A reference test is required before restarting the current calibration period (See **A8.2.2**). If changes are contemplated, contact the TMC beforehand to ascertain the effect changes may have on the current test stand calibration status.

11.4.5 *Test Numbering* – Number each Ford VTW test to identify the test-stand number, stand run number, engine-serial number, and run hours on the engine. For example, 606-0120-0010-0200 defines the 120th test on stand 606, using the engine with serial number 0010, which has run 200 hours prior to this test. A test number of 158-0095-0009-0000 defines the 95th test on stand 158, using the engine with serial number 0009, which is the first test on the engine block. At the start of the test, the engine hours shall not be greater than or equal to 1000 hours.

¹⁹ The Lubricant Test Monitoring System may be obtained from the ASTM Test Monitoring Center, 203 Armstrong Drive, Freeport, PA 16229, Attention: Administrator.

12. Report

12.1 For reference oil results, use the standardized report form set available from the ASTM TMC and data dictionary for reporting test results and for summarizing operational data.

12.1.1 Fill out the report forms according to the formats shown in the data dictionary.

12.1.2 Transmit results to the TMC preferably within five working days of test completion.

12.1.3 Transmit the results electronically as described in the ASTM Data Communications Committee Test Report Transmission Model (Section 2—Flat File Transmission Format) available from the ASTM TMC. Upload files via the TMC's website.

12.2 Report all reference oil test results, whether aborted, invalidated, or successfully completed, to the TMC.

12.3 *Deviations from Test Operational Limits*—Report all deviations from specified test operational limits.

12.4 *Precision of Reported Units*—Use the Practice E29 rounding off method for critical pass/fail test result data. Report the data to the same precision as indicated in the data dictionary.

12.5 In the space provided, note the time, date, test hour, and duration of any shutdown or off-test condition. Document the outcome of all prior reference oil tests from the current calibration sequence that were operationally or statistically invalid.

12.6 If a calibration period is extended beyond the normal calibration period length, make a note in the comment section and attach a written confirmation of the granted extension from the TMC to the test report. List the outcomes of previous runs that may need to be considered as part of the extension in the comment section

13. Precision and Bias

13.1 *Precision*:

13.1.1 Test precision is established on the basis of operationally valid reference oil test results monitored by the ASTM Test Monitoring Center.

13.1.2 *Intermediate Precision Conditions*—Conditions where test results are obtained with the same test method using the same test oil, with changing conditions such as operators, measuring equipment, test stands, test engines, and time.

13.1.2.1 *Intermediate Precision Limit (i.p.)*—The difference between two results obtained under intermediate precision conditions that would, in the long run, in the normal and correct conduct of the test method, exceed the value shown in **Table 9** in only one case in twenty. When only a single test result is available, the Intermediate Precision Limit can be used to calculate a range (test result \pm Intermediate Precision Limit) outside of which a second test result would be expected to fall about one time in twenty.

13.1.3 *Reproducibility Conditions*—Conditions where test results are obtained with the same test method using the same test oil in different laboratories with different operators using different equipment

13.1.3.1 *Reproducibility Limit (R)*—The difference between two results obtained under reproducibility conditions that would, in the long run, in the normal and correct conduct of the test method, exceed the value shown in **Table 9** in only one case in twenty. When only a single test result is available, the Reproducibility Limit can be used to calculate a range (test result \pm Reproducibility Limit) outside of which a second test result would be expected to fall about one time in twenty.

13.1.4 The test precision is shown in **Table 9**. The TMC updates precision data frequently, and this information can be obtained by contacting the TMC.

13.1.5 *Bias*—Bias is determined by applying an accepted statistical technique to reference oil test results and, when a significant bias is determined, a severity adjustment is permitted for non-reference oil test results (refer to the TMC for details).

Insert Table 9 Test Precision for Ford 6.7L Valvetrain Wear Test

Precision Table

14. Keywords

ANNEXES

(Mandatory Information)

A1. ASTM TEST MONITORING CENTER ORGANIZATION

A1.1 *Nature and Functions of the ASTM Test Monitoring Center (TMC)*—The TMC is a nonprofit organization located in Pittsburgh, Pennsylvania and is staffed to: administer engineering studies; conduct laboratory inspections; perform statistical analyses of reference-oil test data; blend, store, and ship reference oils; and provide the associated administrative functions to maintain the referencing calibration program for various lubricant tests as directed by ASTM Subcommittee D02.B0 and the TMC Executive Committee. The TMC coordinates its activities with the test sponsors, the test developers, the surveillance panels, and the testing laboratories. Contact TMC through the TMC Director at:

ASTM Test Monitoring Center
203 Armstrong Dr.
Freeport, PA. 16229
412-365-1000
www.astmtmc.org

A1.2 *Rules of Operation of the ASTM TMC*—The TMC operates in accordance with the ASTM Charter, the ASTM Bylaws, the Regulations Governing ASTM Technical Committees, the Bylaws Governing ASTM Committee D02, and the Rules and Regulations Governing the ASTM Test Monitoring System.

A1.3 *Management of the ASTM TMC*—The management of the Test Monitoring System is vested in the Executive Committee elected by Subcommittee D02.B0. The Executive Committee selects the TMC Director who is responsible for directing the activities of the TMC.

A1.4 *Operating Income of the ASTM TMC*—The TMC operating income is obtained from fees levied on the reference oils supplied and on the calibration tests conducted. Fee schedules are established by the Executive Committee and reviewed by Subcommittee D02.B0.

A2. SAFETY PRECAUTIONS

A2.1 General:

A2.1.1 The operating of engine tests can expose personnel and facilities to a number of safety hazards. It is recommended that only personnel who are thoroughly trained and experienced in engine testing should undertake the design, installation and operation of engine test stands.

A2.1.2 Each laboratory conducting engine tests should have their test installation inspected and approved by their Safety Department. Personnel working on the engines should be provided with proper tools, be alert to common sense safety practices, and avoid contact with moving, and hot engine parts, or both. Guards should be installed around all external moving or hot parts. When engines are operating at high speeds, heavy duty guards are required and personnel should be cautioned against working alongside the engine and coupling shaft. Barrier protection should be provided for personnel. All fuel lines, oil lines, and electrical wiring should be properly routed, guarded, and kept in good order. Scraped knuckles, minor burns, and cuts are common if proper safety precautions are not taken. Safety masks or glasses should always be worn by personnel working on the engines and no loose or flowing clothing, including long hair or other accessory to dress which could become entangled, should be worn near running engines.

A2.1.3 The external parts of the engines and the floor area around the engines should be kept clean and free of oil and fuel spills. In addition, all working areas should be free of tripping hazards. Personnel should be alert for leaking fuel or exhaust gas. Leaking fuel represents a fire hazard and exhaust gas fumes are noxious. Containers of oil or fuel cannot be permitted to accumulate in the testing area.

A2.1.4 The test installation should be equipped with a fuel shut-off valve which is designed to automatically cutoff the fuel supply to engine when the engine is not running. A remote station for cutting off fuel from the test stand is recommended. Suitable interlocks should be provided so that the engine is automatically shut down when any of the following events occur: engine or dynamometer water temperature becomes excessive; engine loses oil pressure; dynamometer loses field current; engine over-speeds; exhaust system fails; room ventilation fails; or the fire protection system is activated.

A2.1.5 Consider an excessive vibration pickup interlock if equipment operates unattended. Fixed fire protection equipment should be provided.

A2.1.6 Normal precautions should be observed whenever using flammable solvents for cleaning purposes. Make sure adequate firefighting equipment is immediately accessible

A3. PARTS LIST

A3.1 The parts listings includes approved parts required for:

A3.1.1 Critical Test Parts.

A3.1.2 Replaced Parts.

A3.1.3 Reusable Parts.

A4. TEST STAND SETUP Drawings, Photos, Illustrations

Temperature, Pressure, and Other Control Systems

A4.1 See **Figures A4.1** through **A4.35** for details.

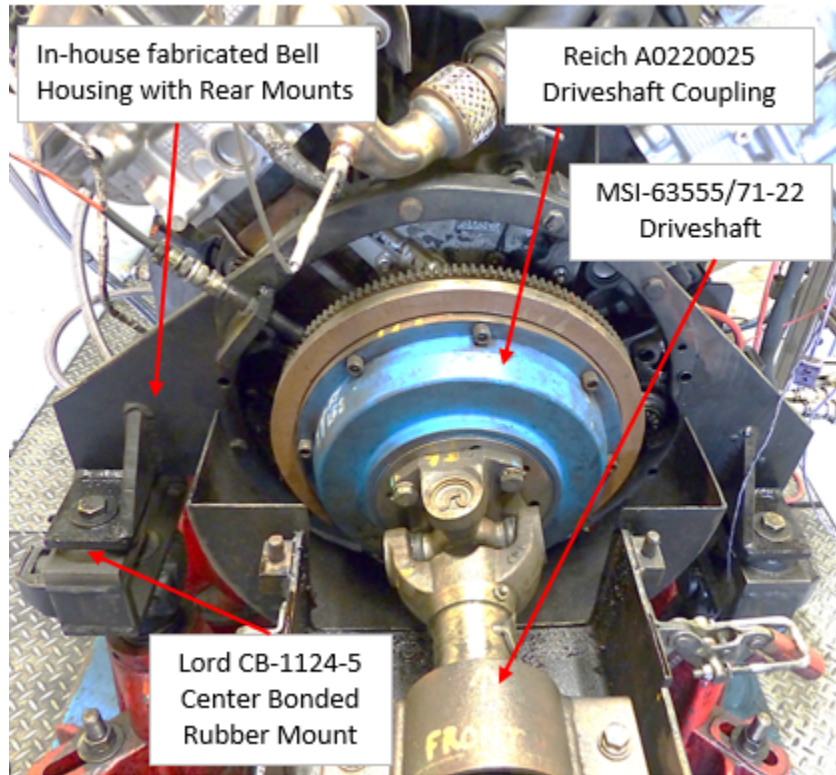

FIGURE A4.1 TYPICAL REAR ENGINE MOUNT SETUP

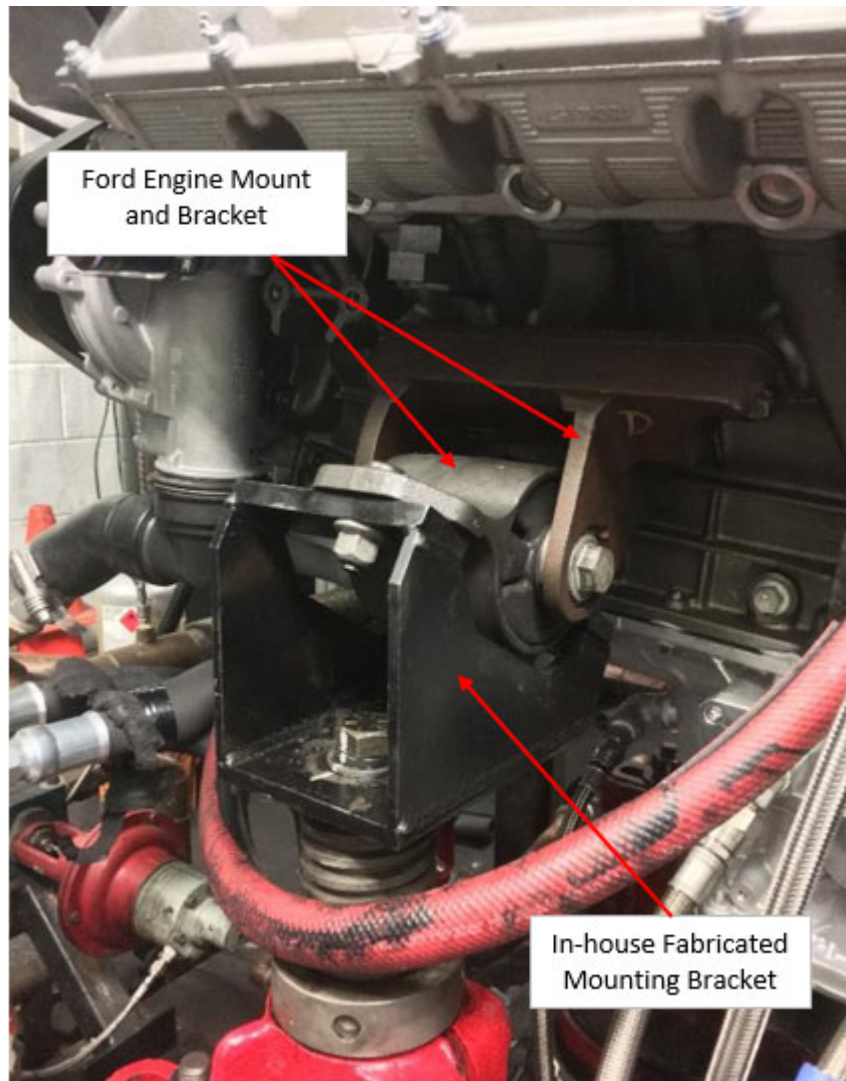

FIGURE A4.2 TYPICAL LEFT FRONT ENGINE MOUNT



FIGURE A4.3 TYPICAL RIGHT FRONT ENGINE MOUNT

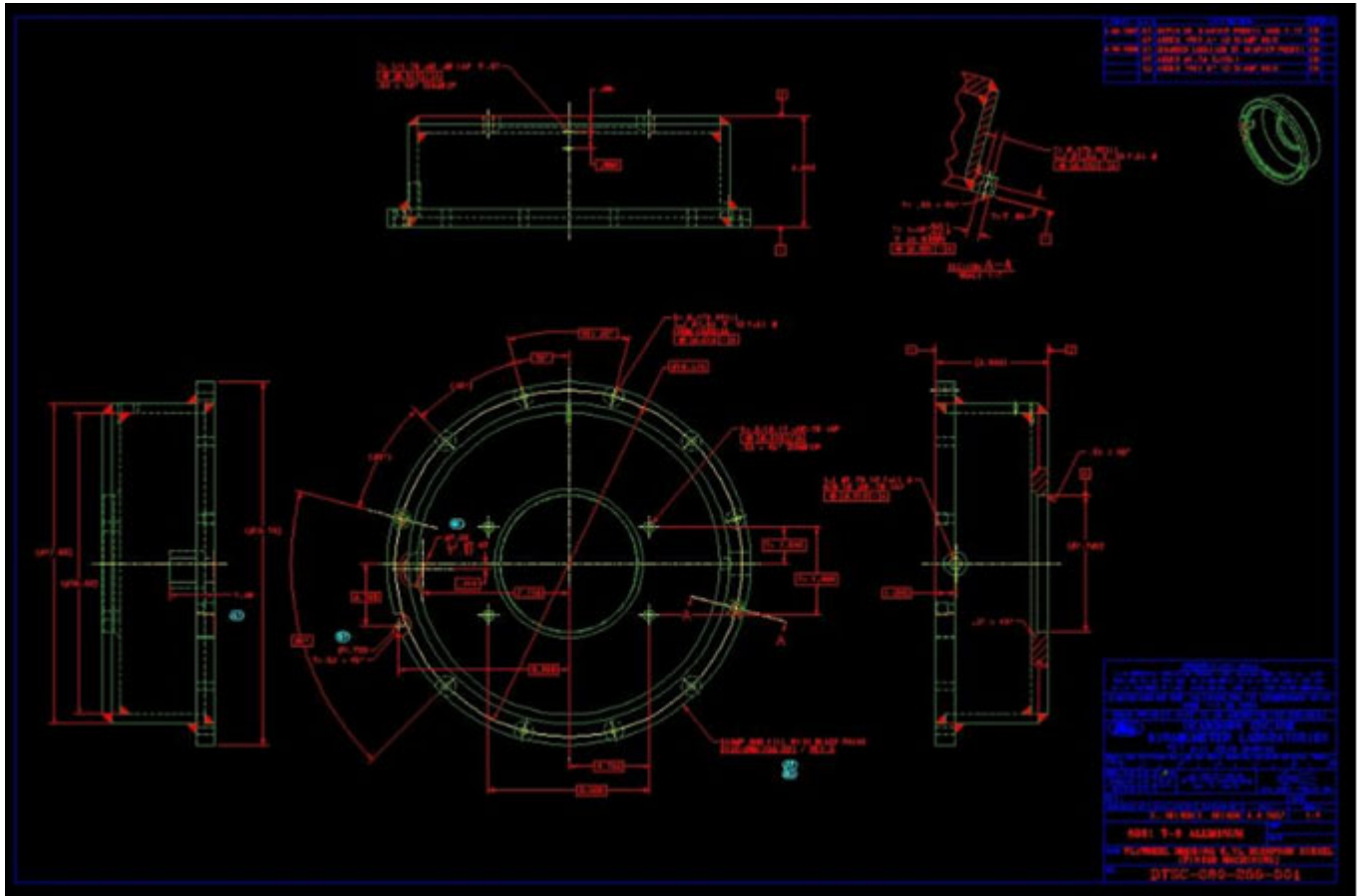

Figure A4.4 Flywheel Cover Part Drawing

Drawing also available at TMC.

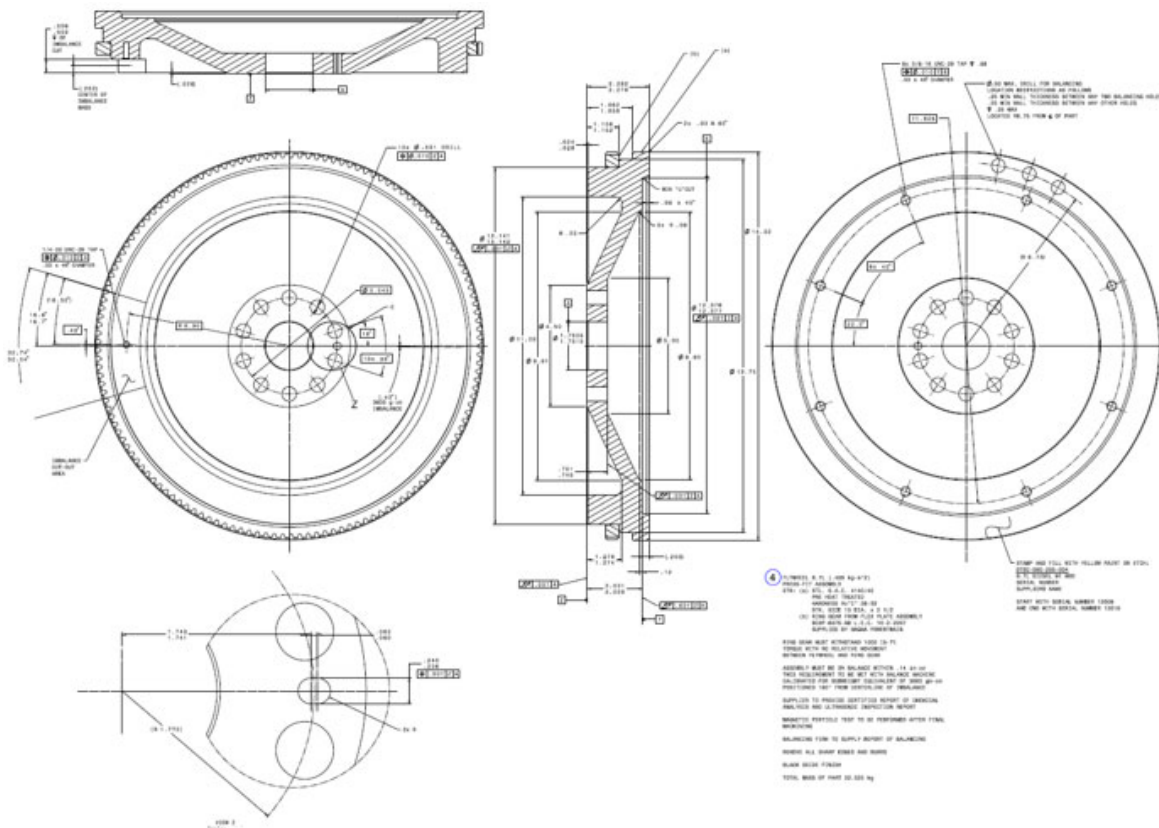

Figure A4.5 Flywheel Part Drawing

Drawing also available at TMC Website

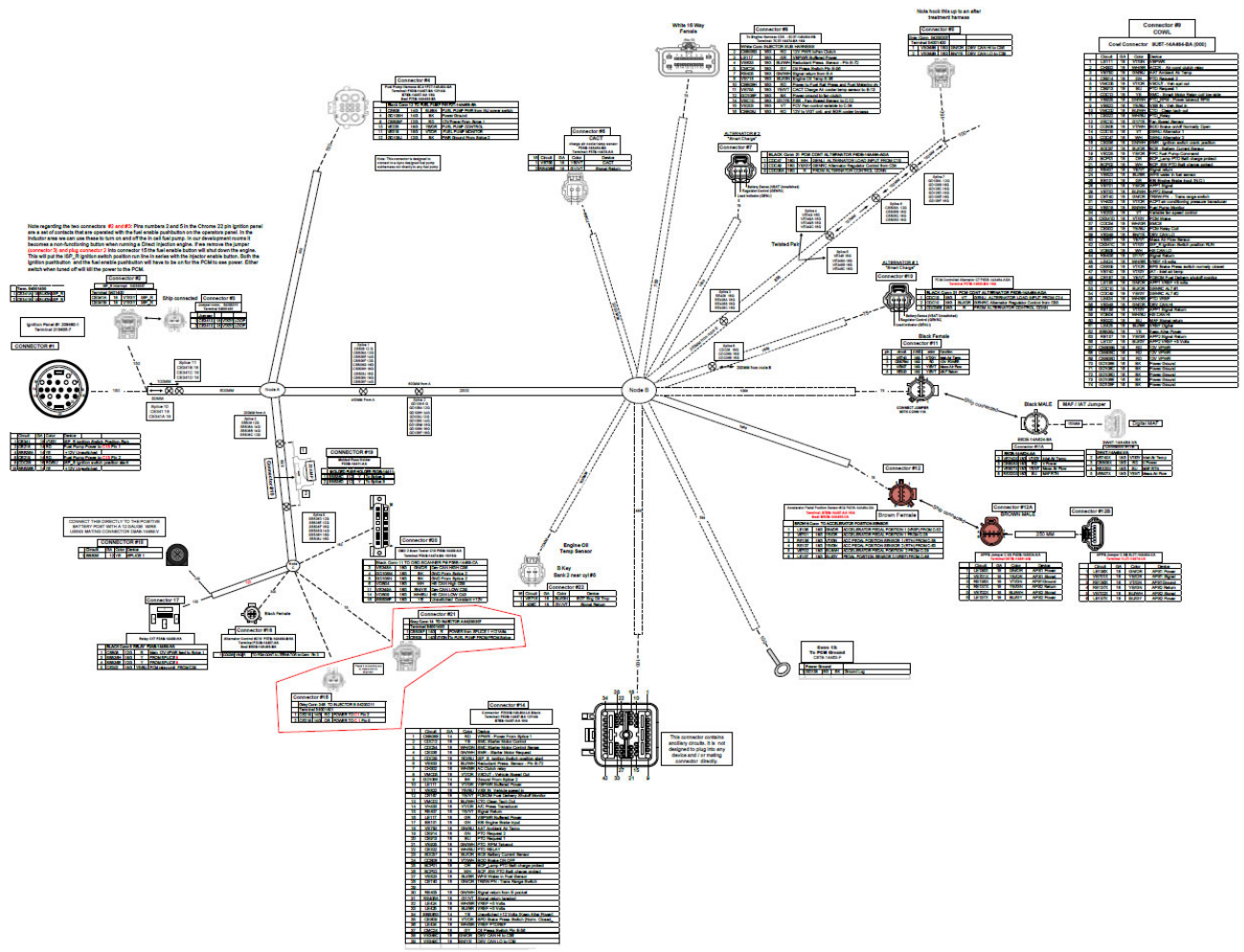
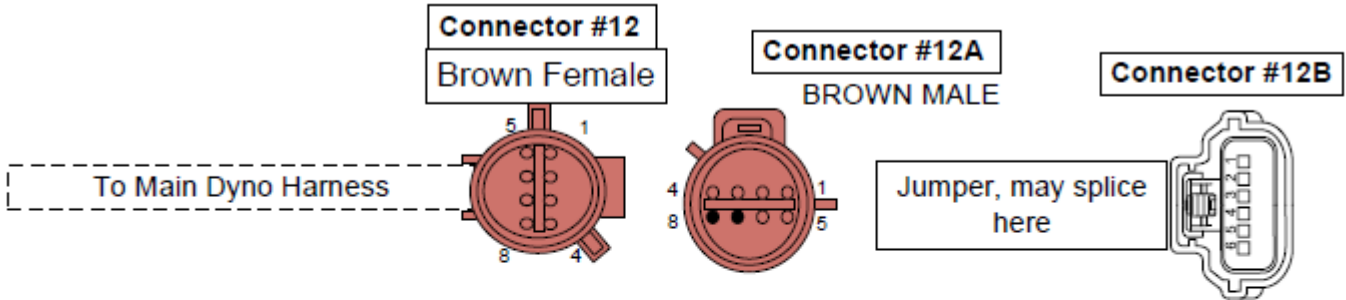

Figure A4.6 Wire Harness Diagram
 Drawing also available at TMC Website



Pin Numbers Apply to All Connectors				
1	LE136	18G	GN/OR	5V Signal for Acc Pos Sensor 1, Do Not Connect
2	VE701	18G	YE/OR	Acc Pos Sensor 1 Voltage from Stand (0-5V)
3	RE136	18G	VT/GN	Acc Pos Sensor 1 Ground
4	RE137	18G	YE/GN	Acc Pos Sensor 2 Ground
5	VE702	18G	BU/WH	Acc Pos Sensor 2 Voltage from Stand (0-2.5V)
6	LE137	18G	BU/GY	5V Signal for Acc Pos Sensor 2, Do Not Connect

Figure A4.6B Accelerator Pedal Pin Call-out

ECT
Engine Coolant
Temperature Sensor

(Key B)

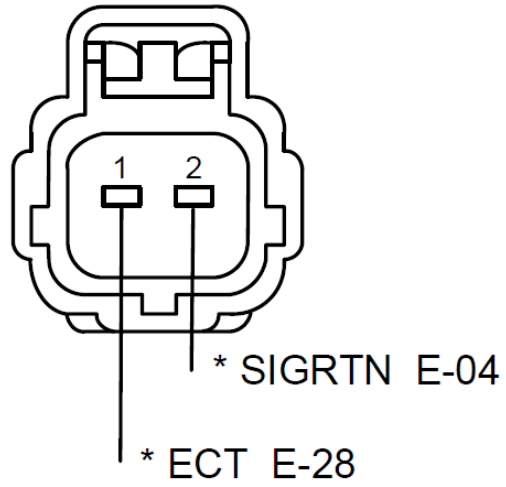

Figure A4.6C Coolant Sensor Pin-out

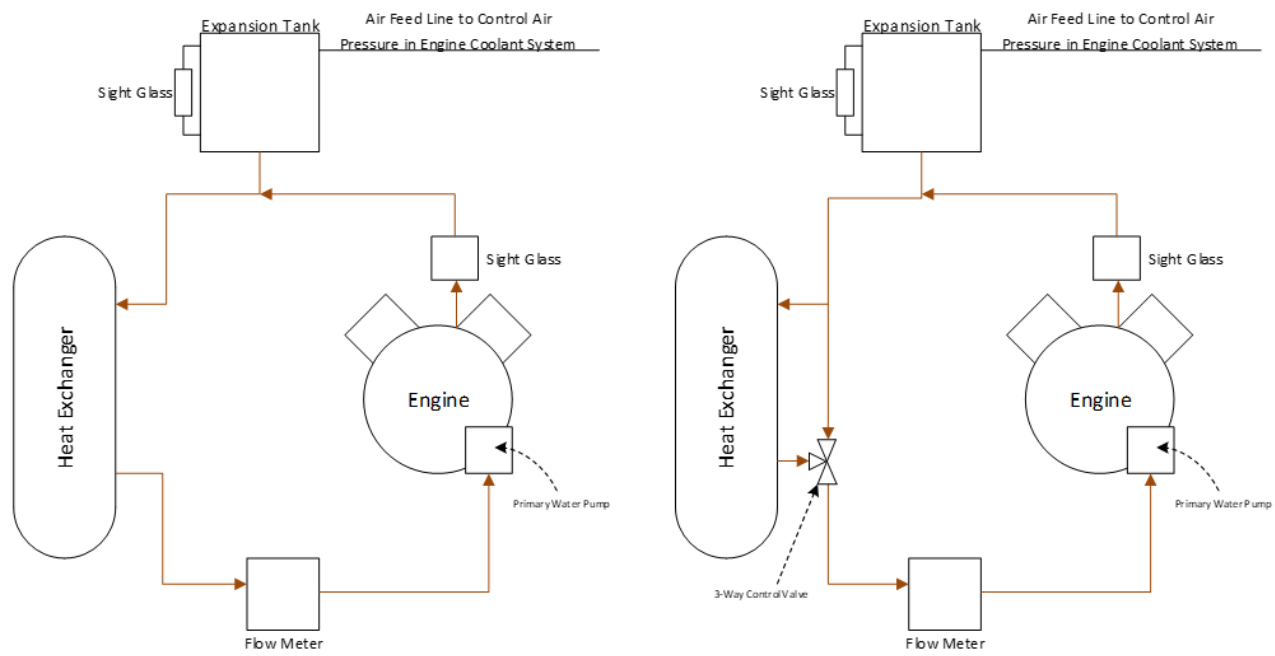

Figure A4.7 Primary Coolant System Schematics (Left: Option 1, Right: Option 2)

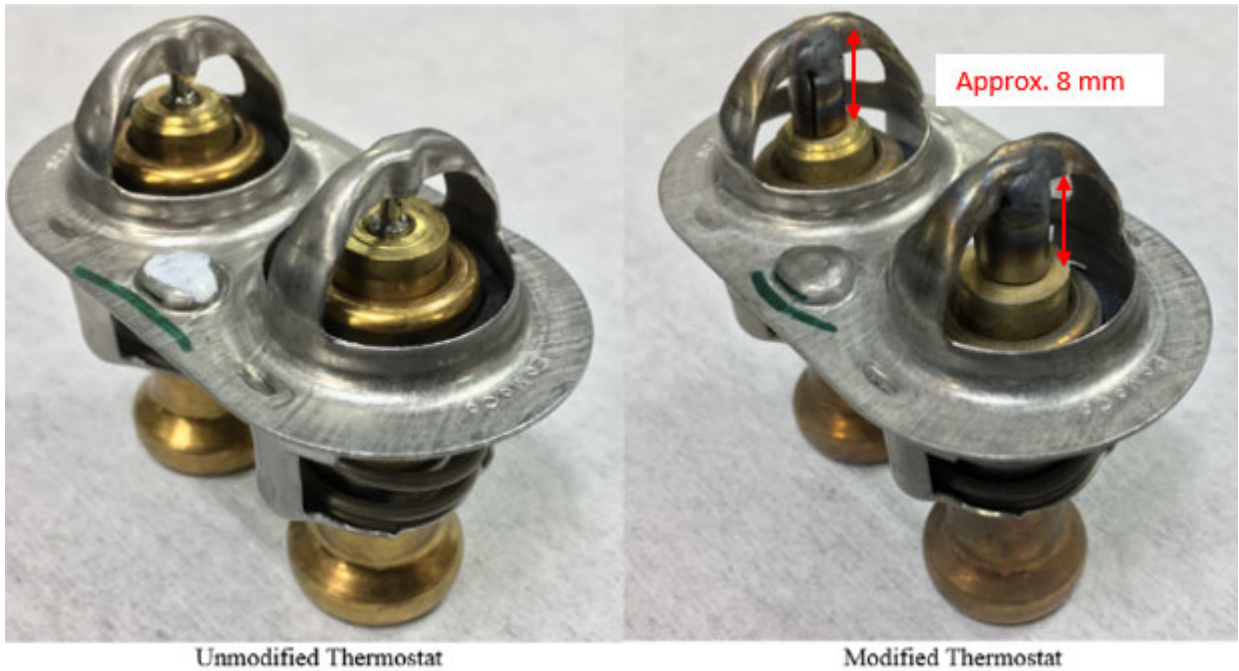

Figure A4.8 Engine Thermostat

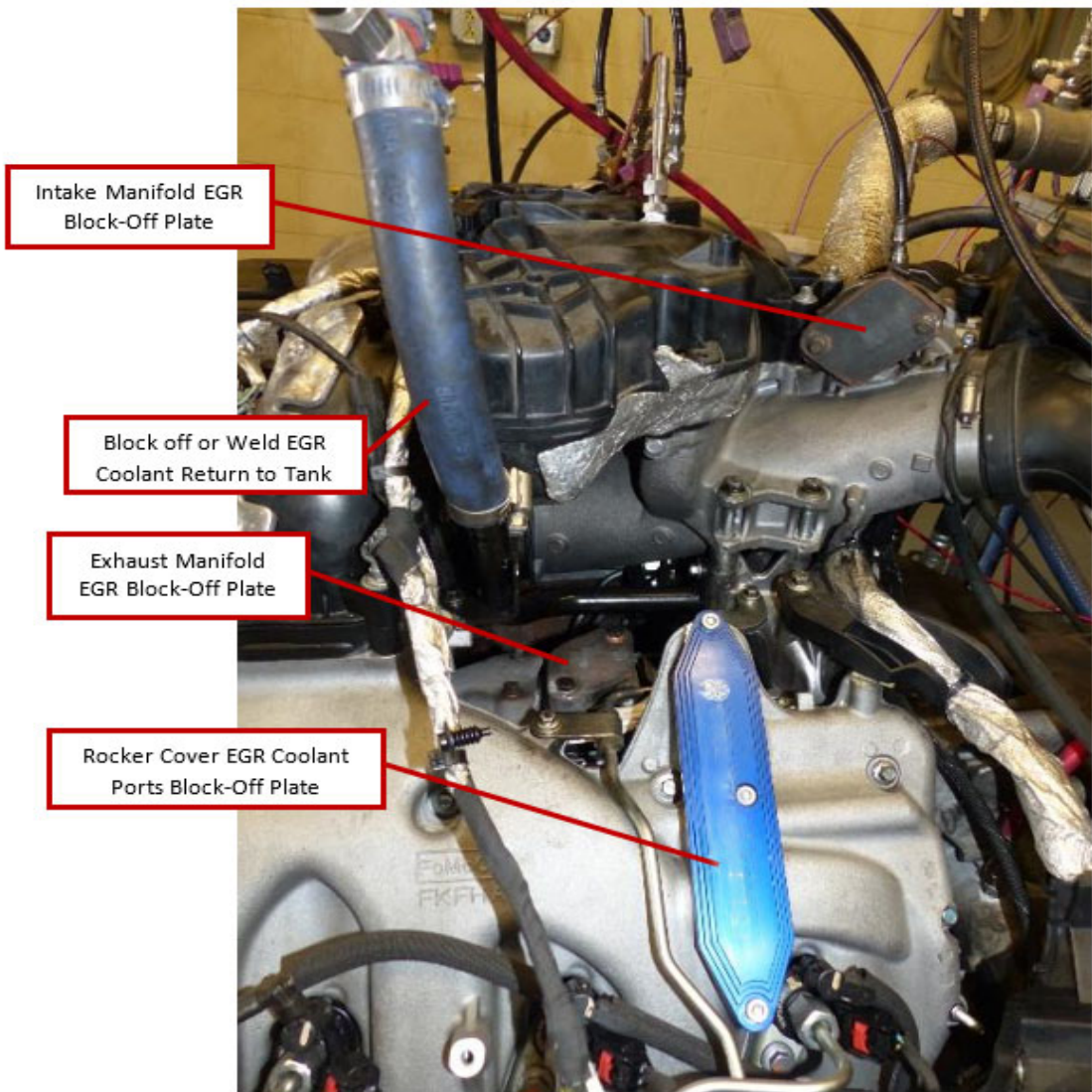

Figure A4.9 EGR System Modifications

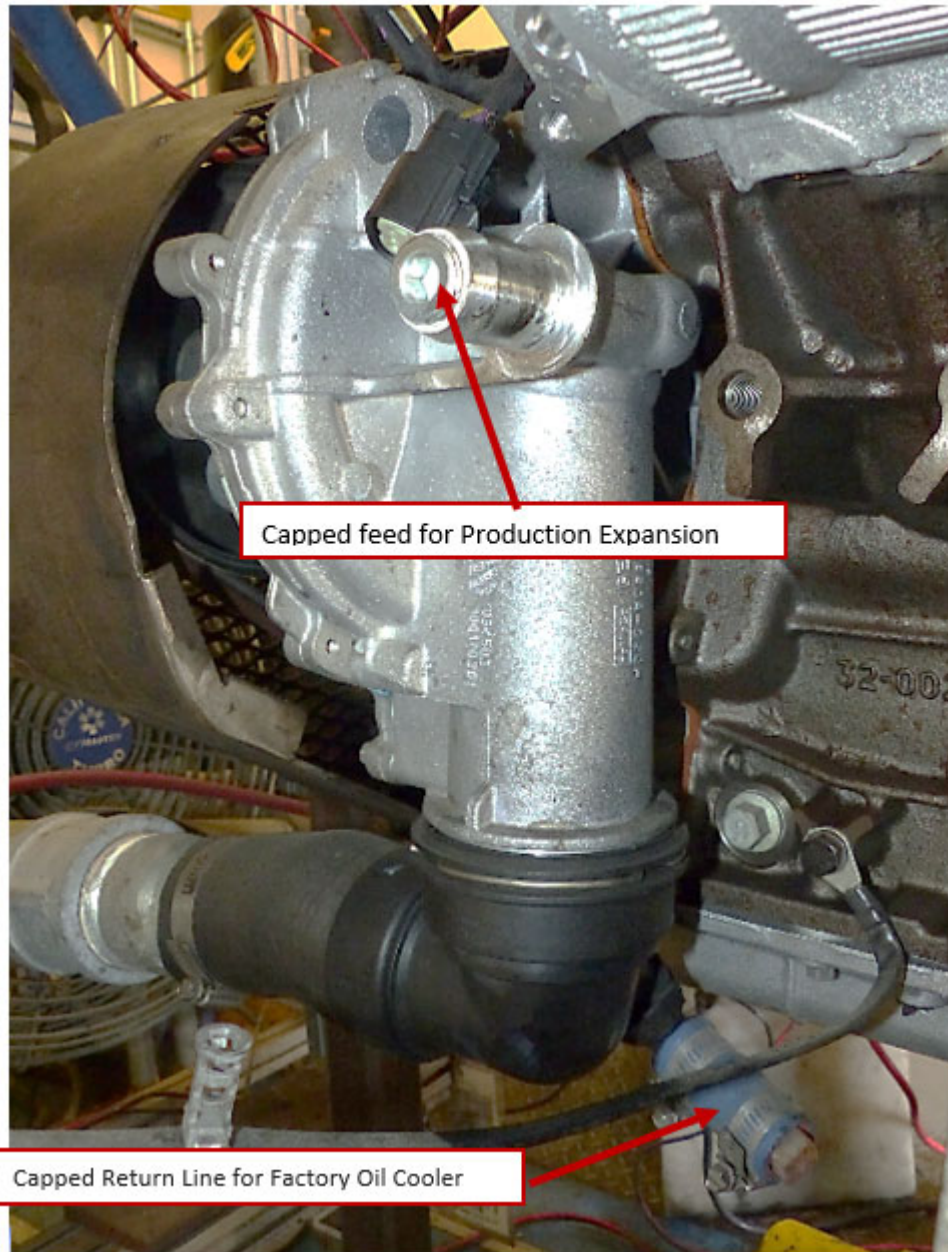

Figure A4.10 Capped Production Expansion Tank Feed on Primary Water Pump

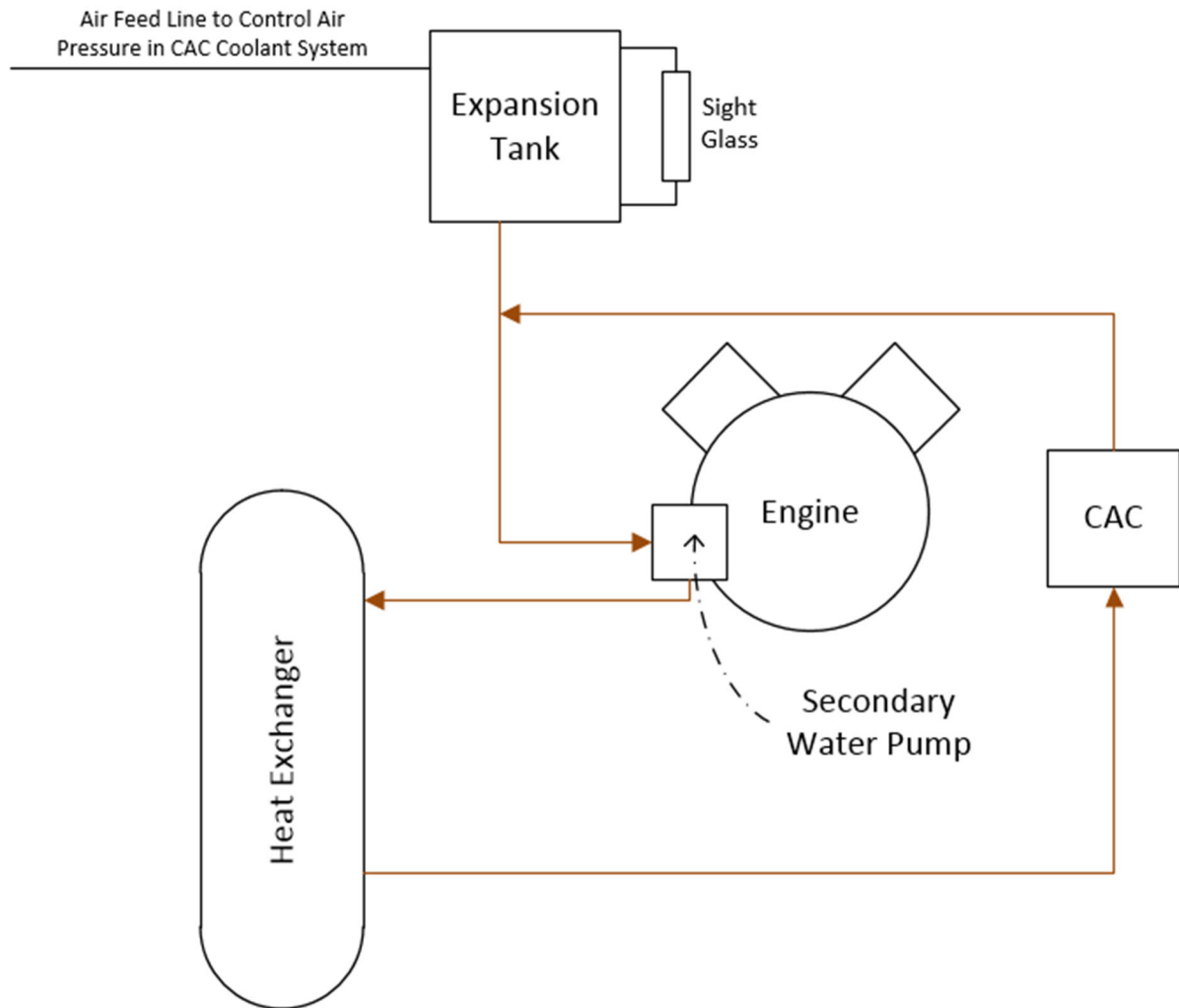

FIGURE A4.11 TYPICAL SECONDARY COOLANT SYSTEM SCHEMATIC

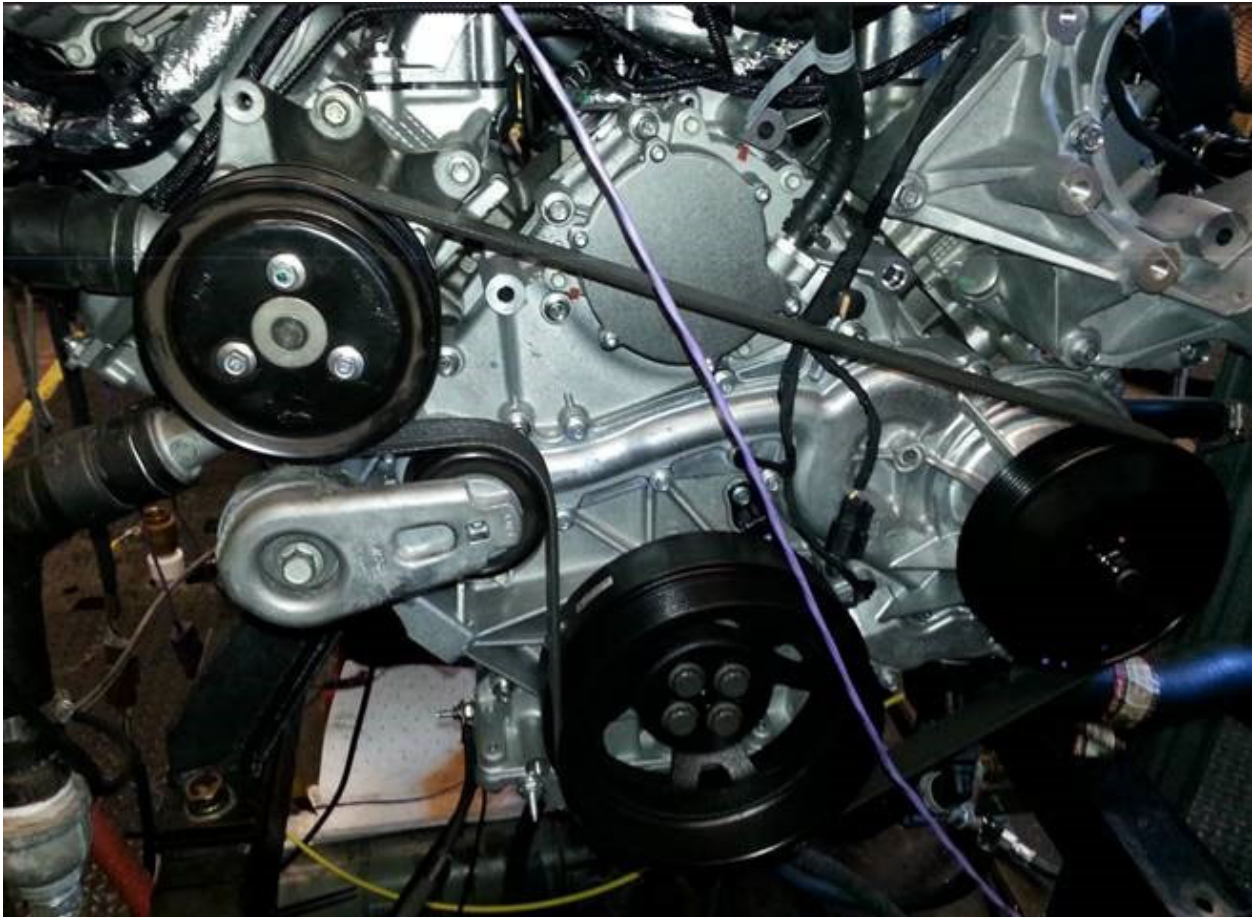

Figure A4.12 Typical Front End Accessory Drive

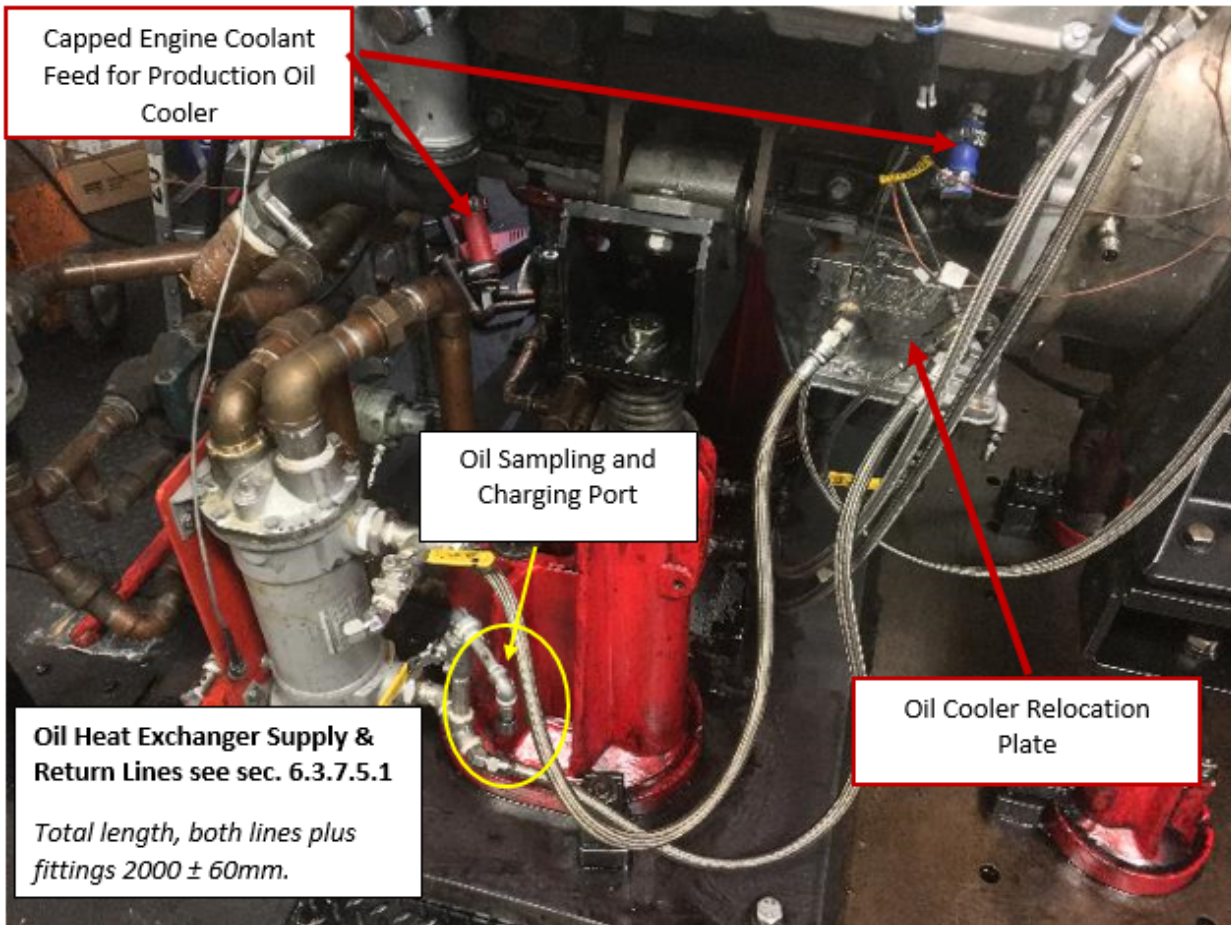

Fig A4.13 Oil-Cooling System

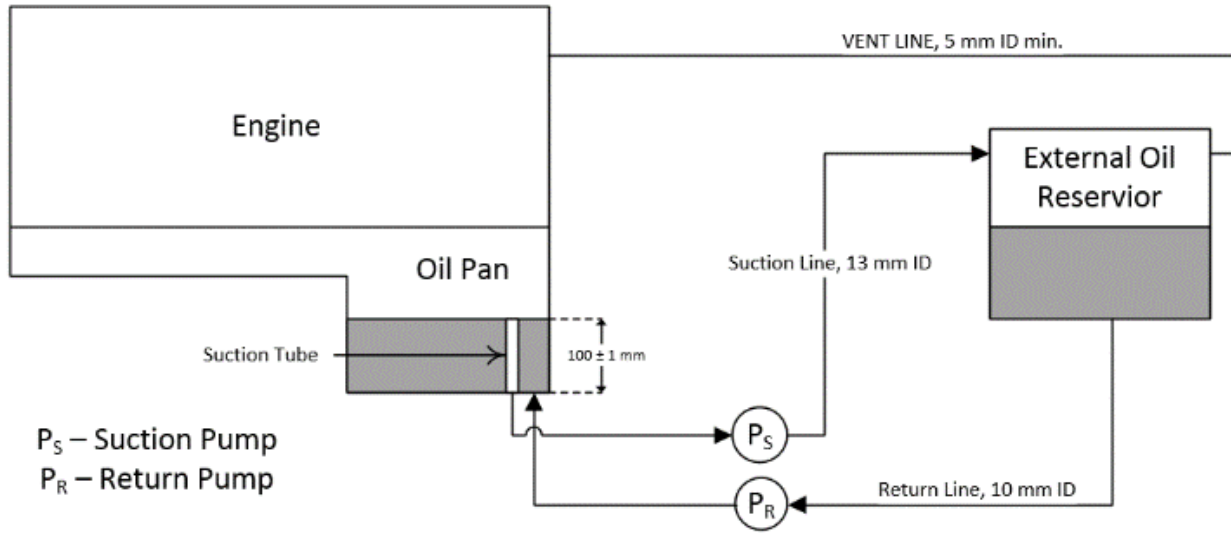

Figure A4.14 Schematic of Auxiliary Oil System

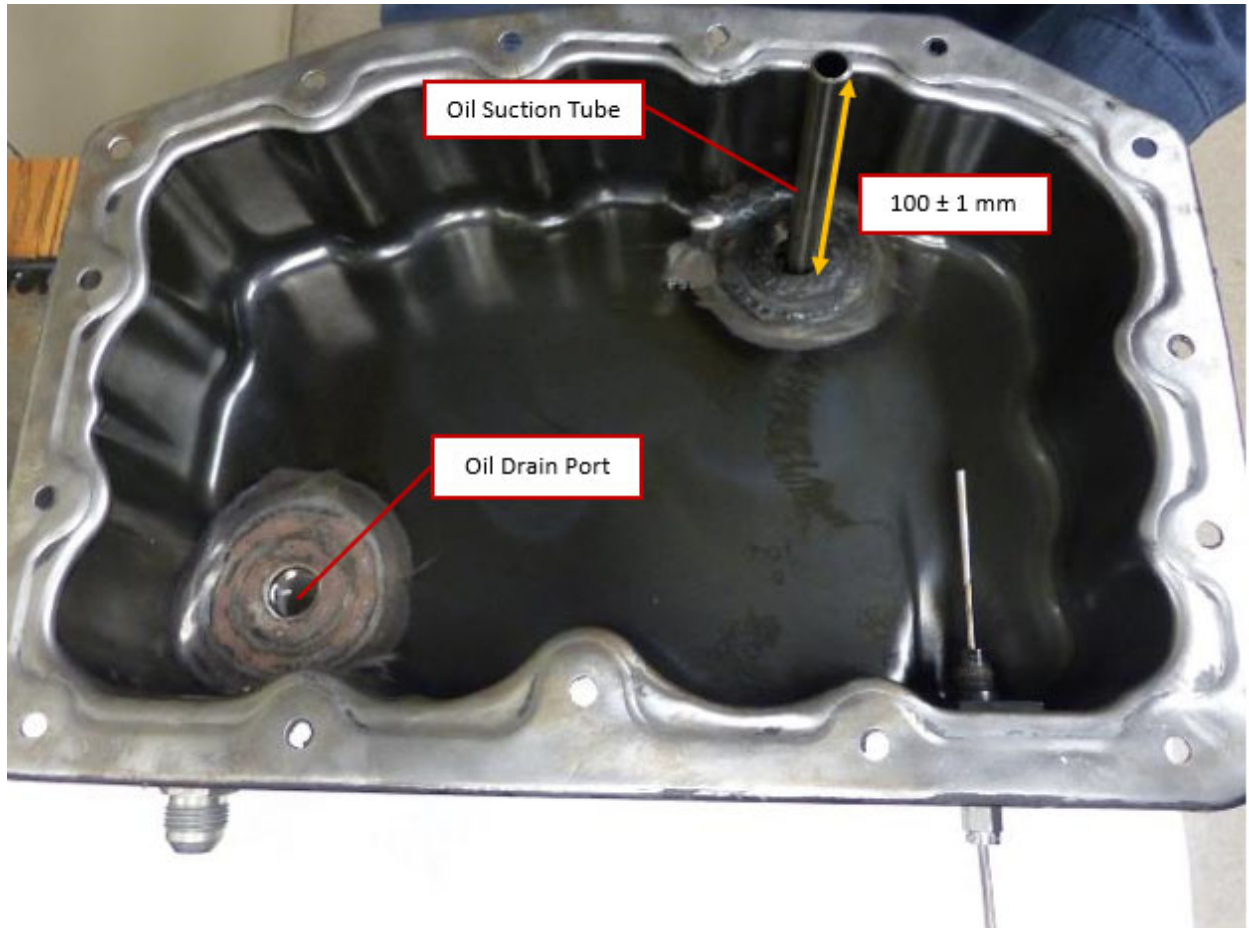
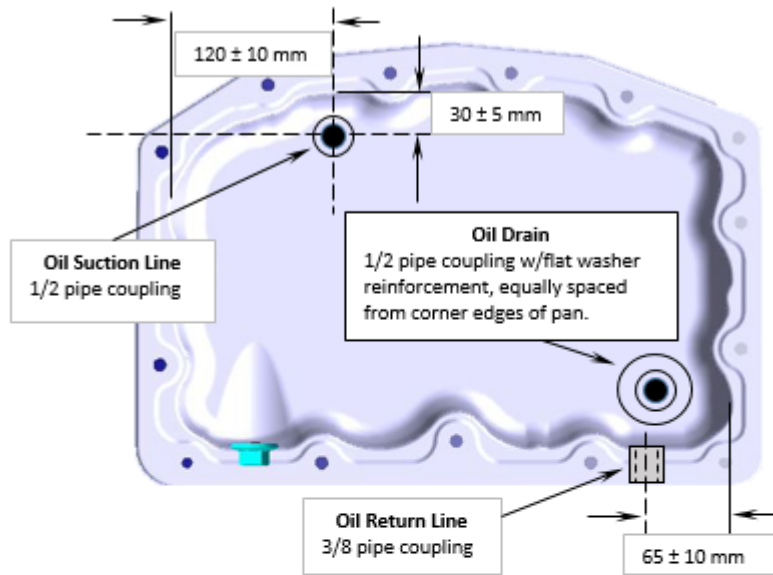

Figure A4.15 Oil Pan Drain and Suction line for Auxiliary Oil-System



Ford 6.7L VTW Test Oil Pan Weldment Modifications

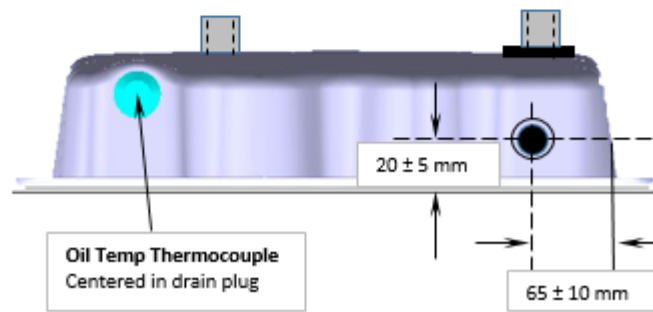

Figure A4.16 Lower Oil Pan Modifications

Call-out as viewed from
rear of upper oil pan

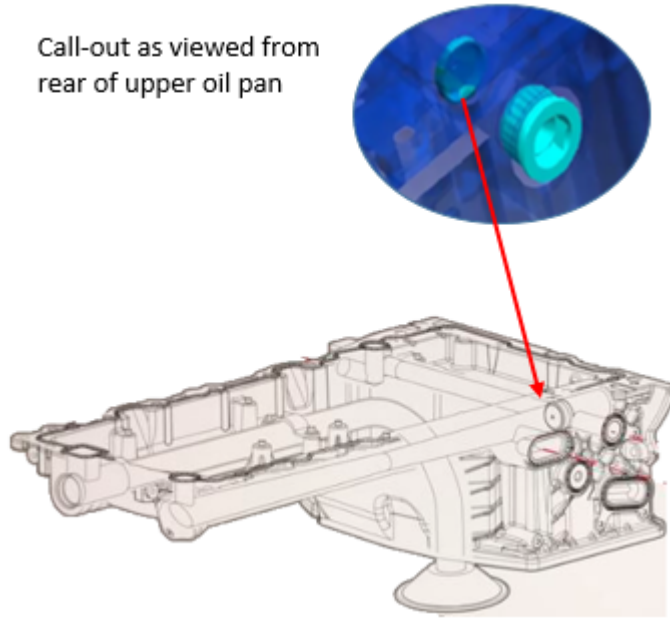

Figure A4.17 Oil Cooler By-Pass Modification

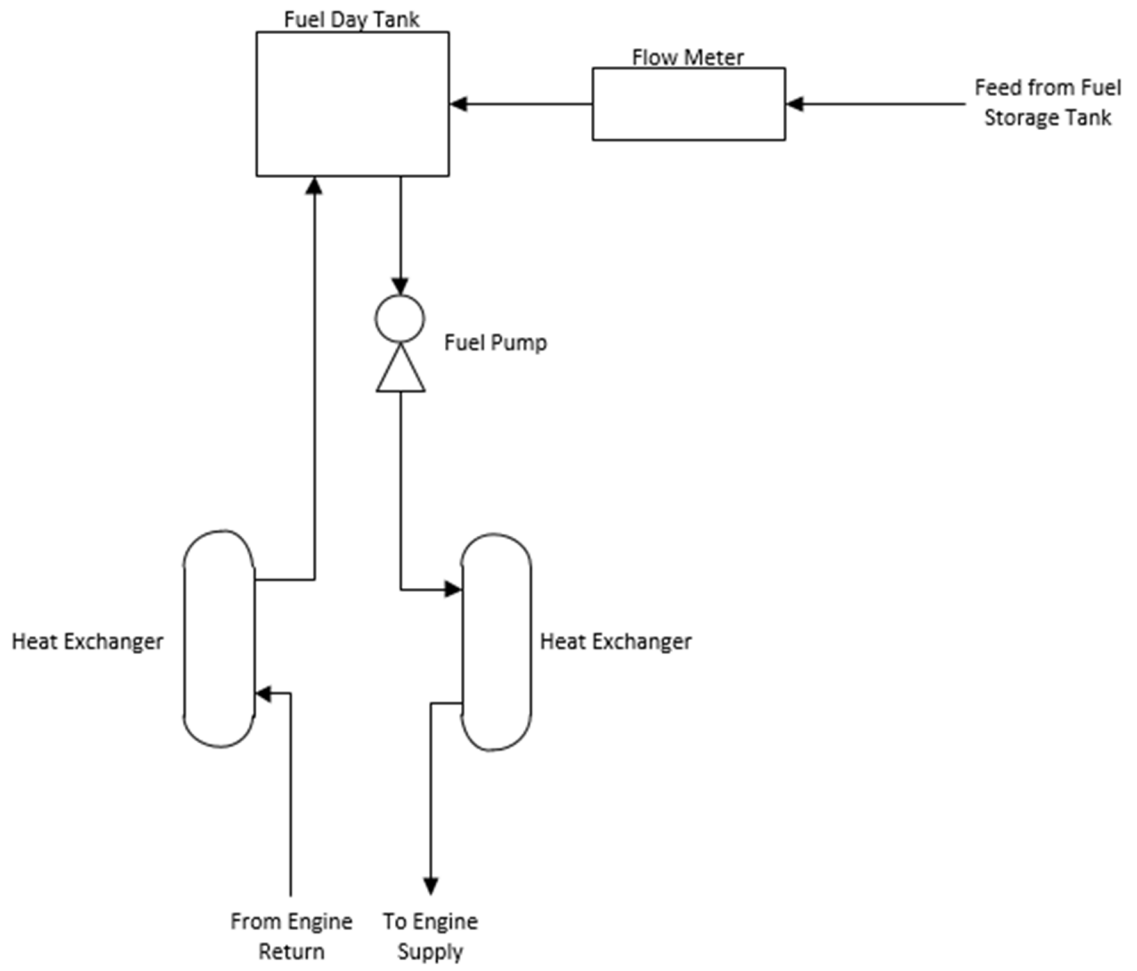

Figure A4.18 Schematic of Typical Fuel System

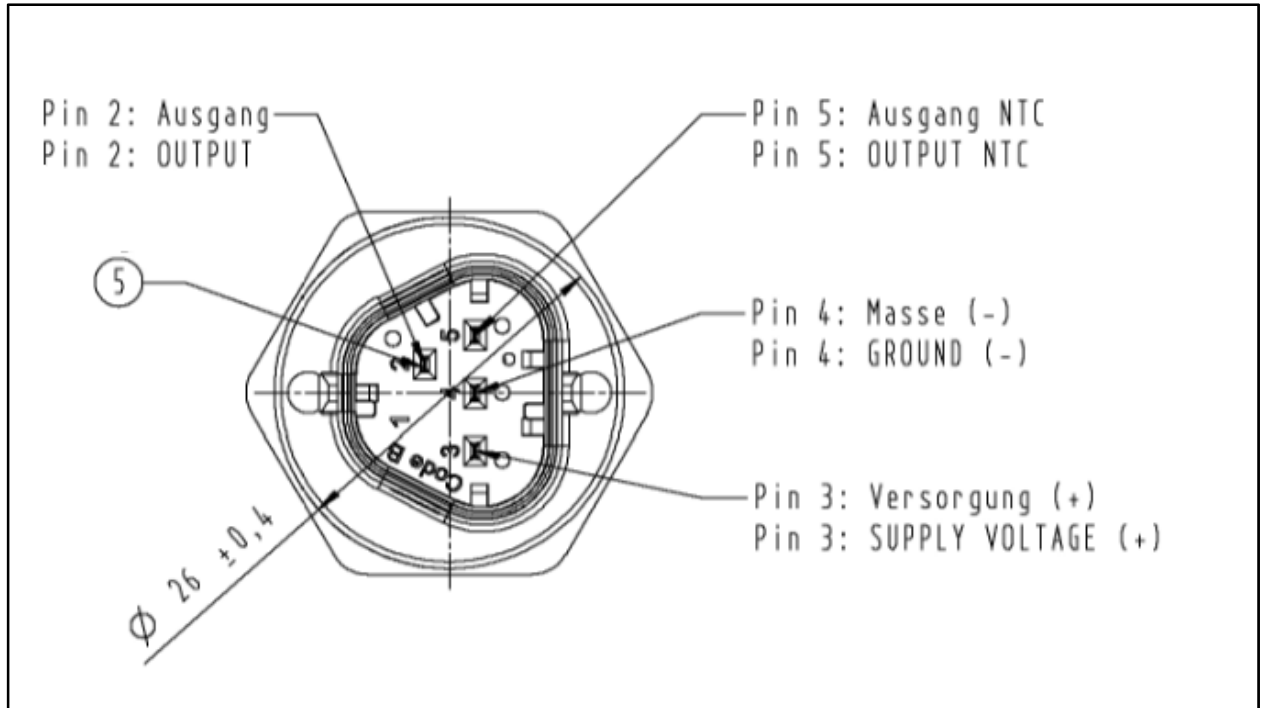

Figure A4.19 Fuel Pressure and Temperature Sensor Pinout

Drawing Available at TCM Website

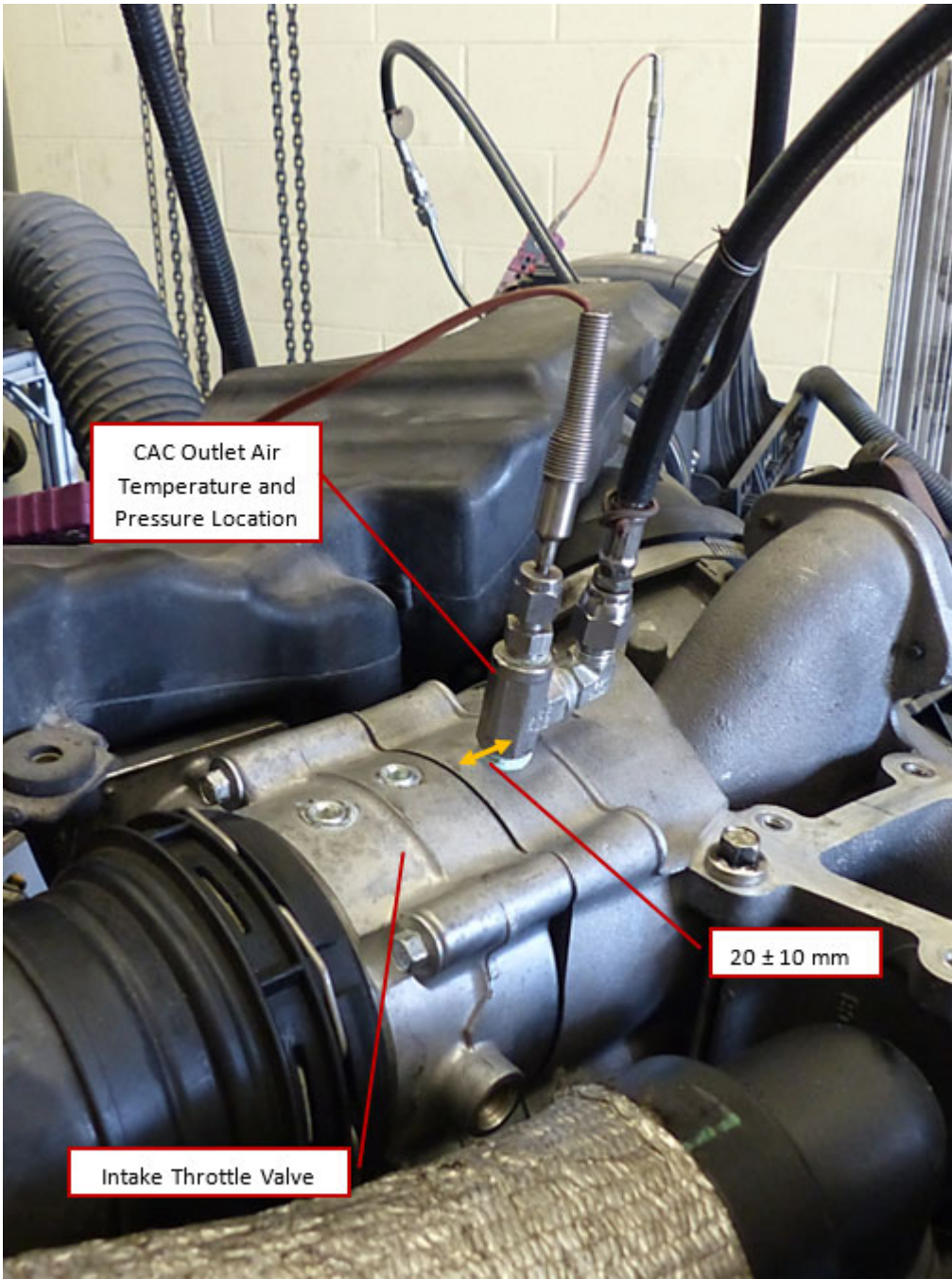

Figure A4.20 Air Temperature at CAC Outlet Thermocouple Location

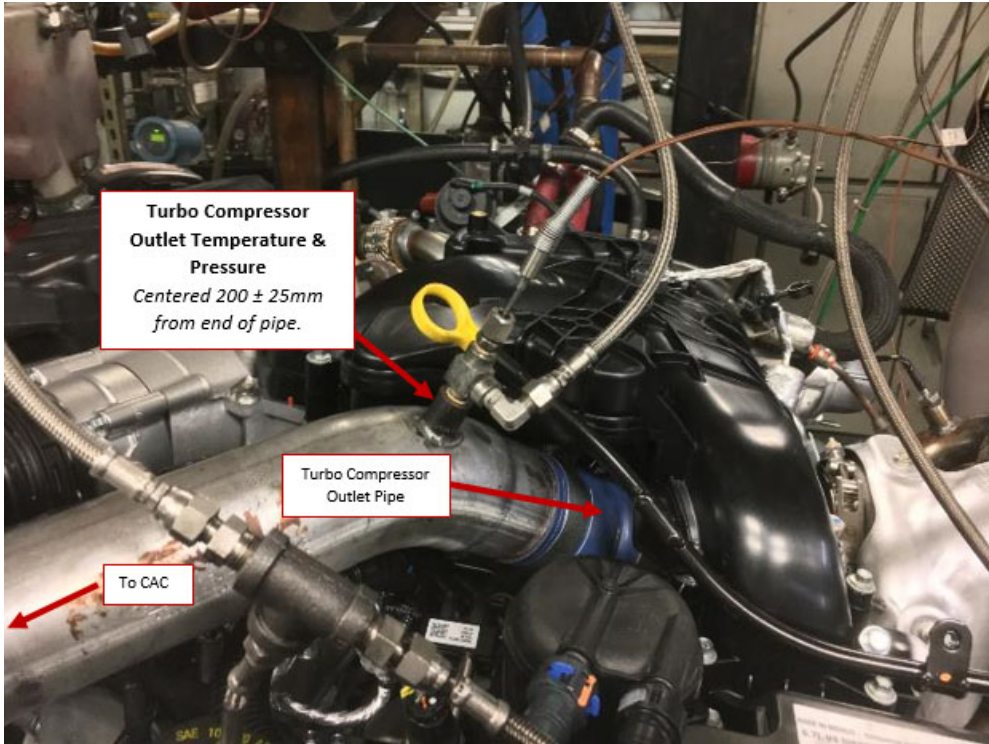

Figure A4.21 Air Temperature at Turbo-Compressor Outlet Thermocouple Location

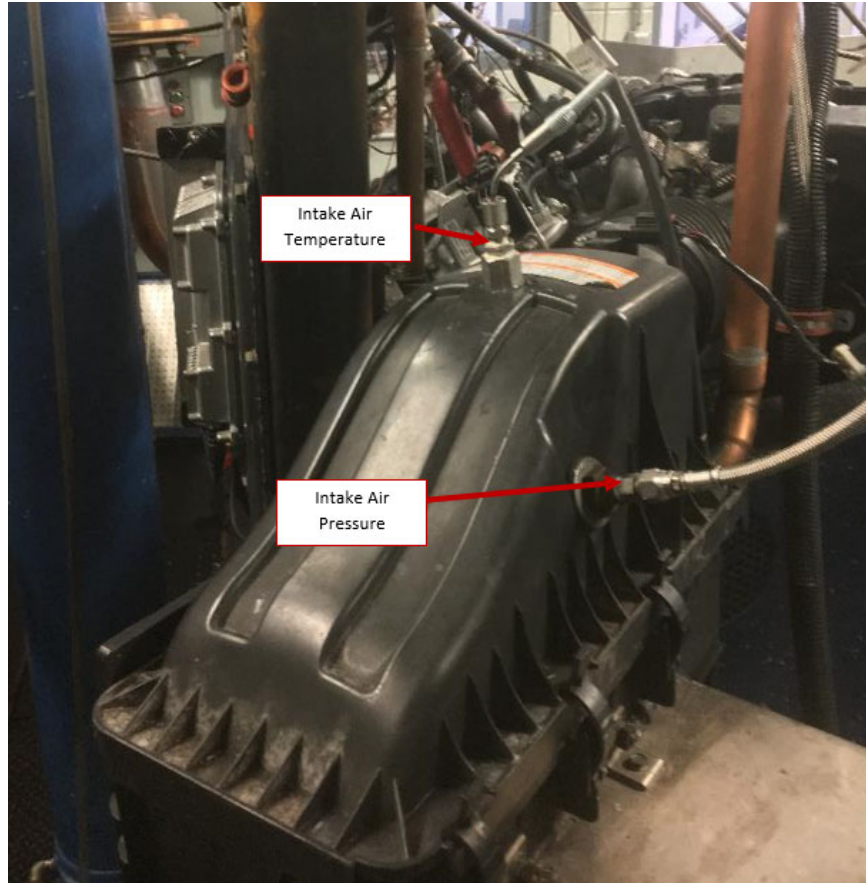

Figure A4.22 Air Temperature and Air Pressure in Engine Intake Sensor Locations

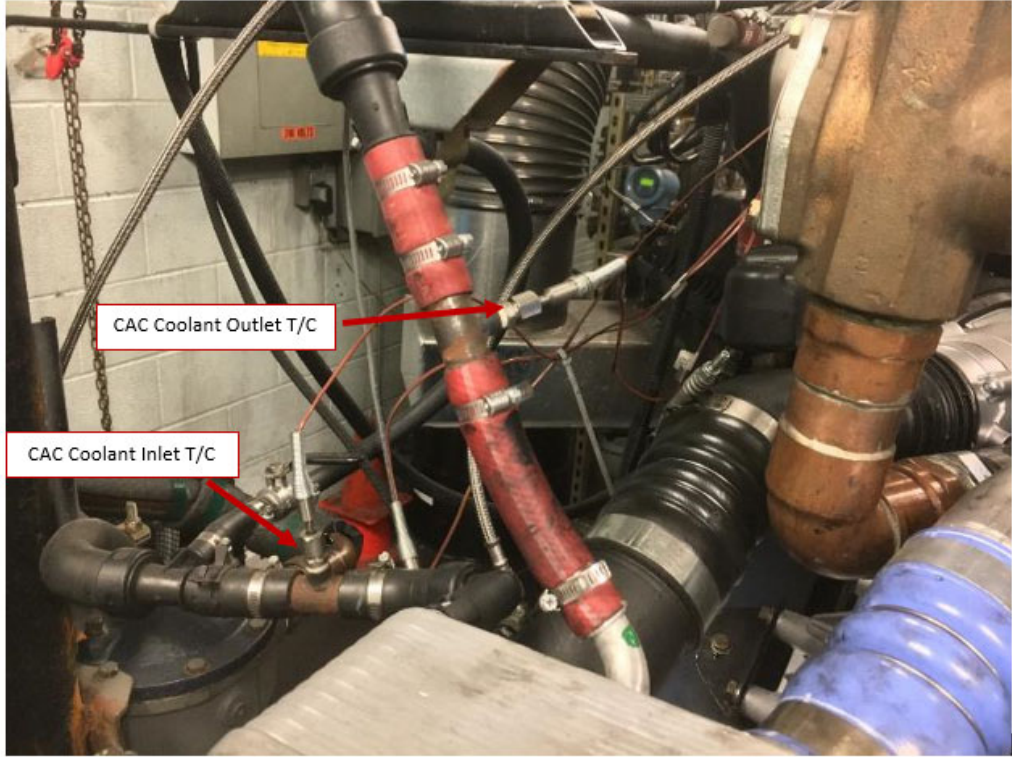

Figure A4.23 Example CAC Coolant-Inlet and Outlet Thermocouple Location

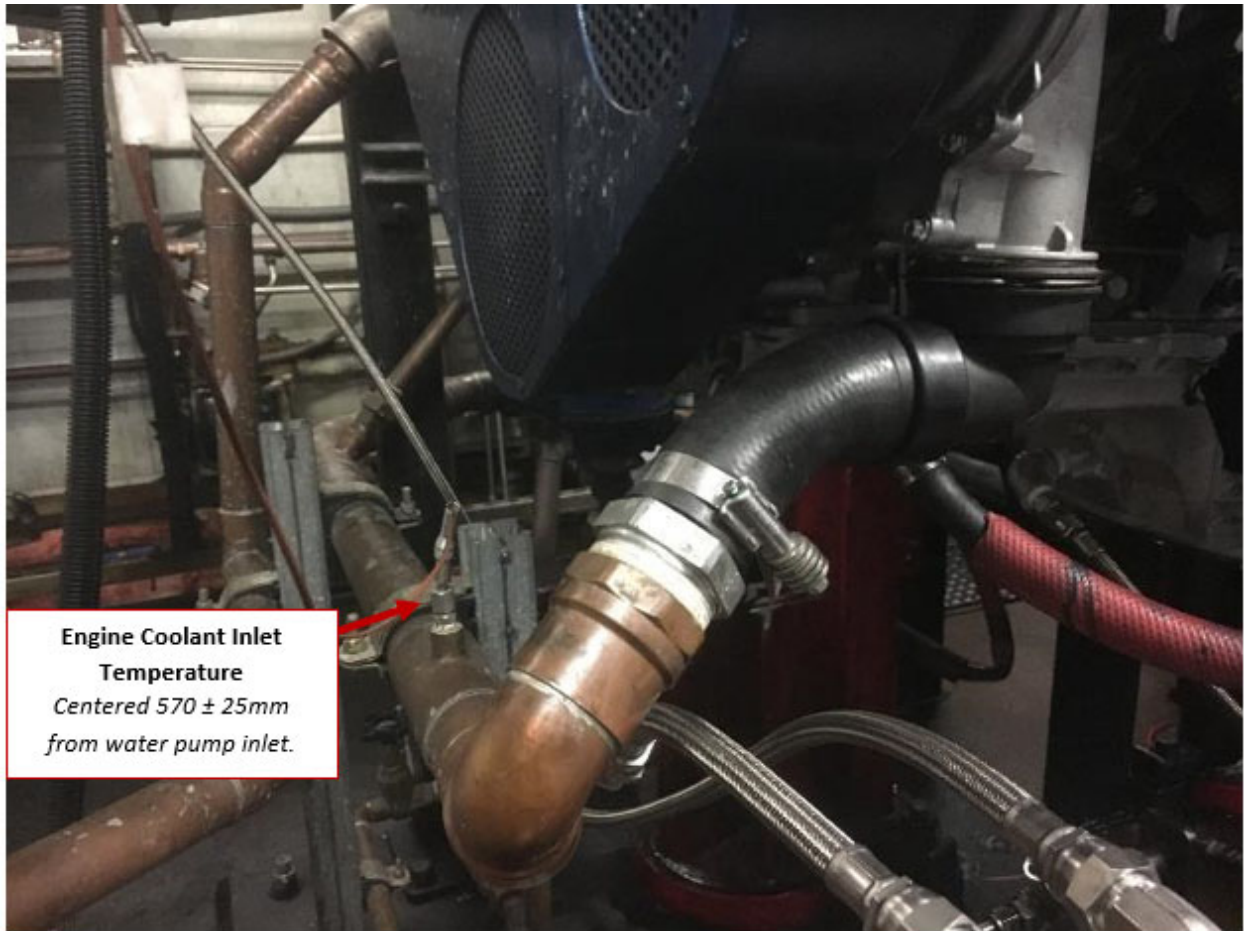

Figure A4.24 Engine Coolant Inlet Thermocouple Location

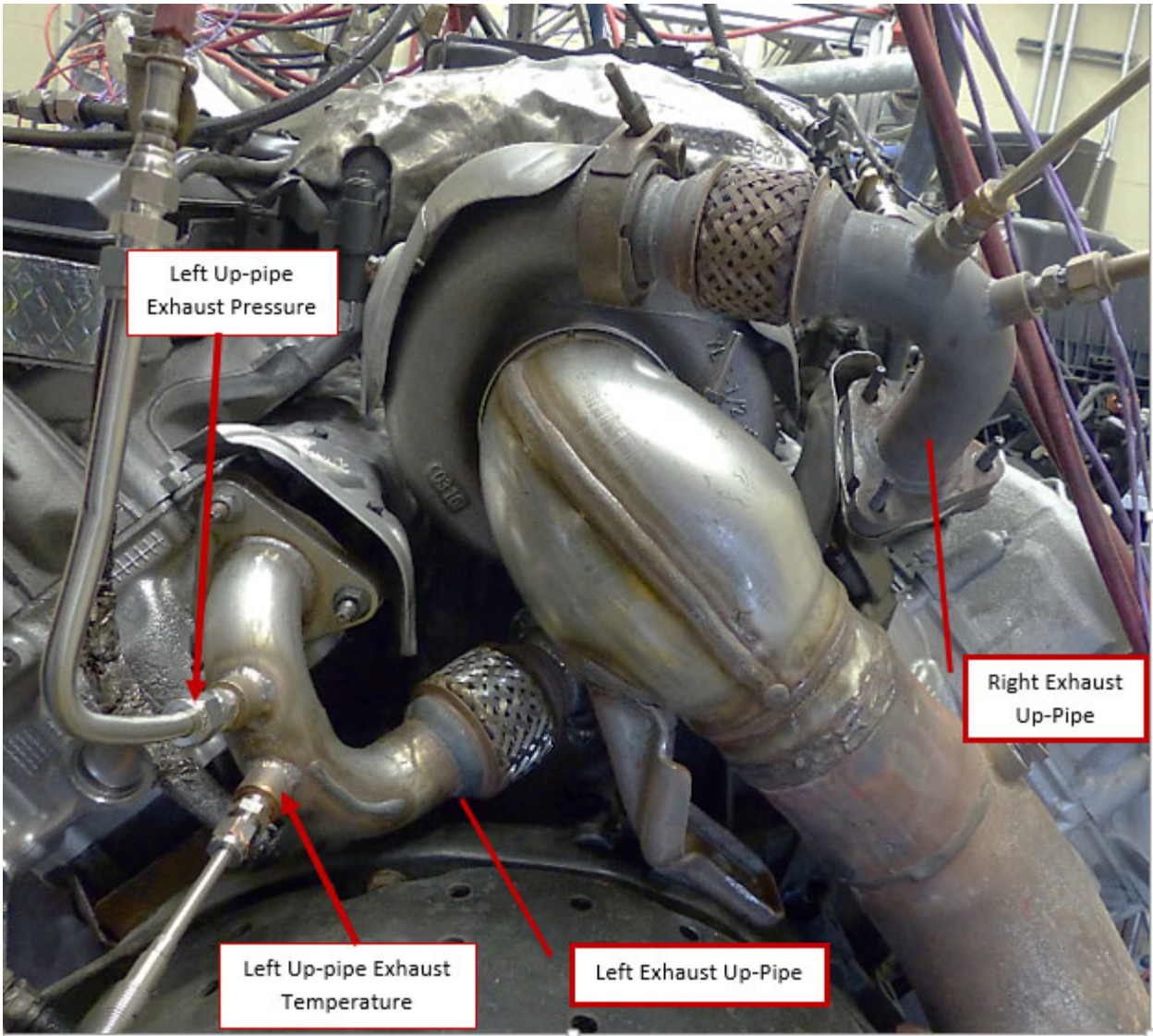

Figure A4.25 Example Left and Right Exhaust Up-Pipe Pressure and Thermocouple Locations

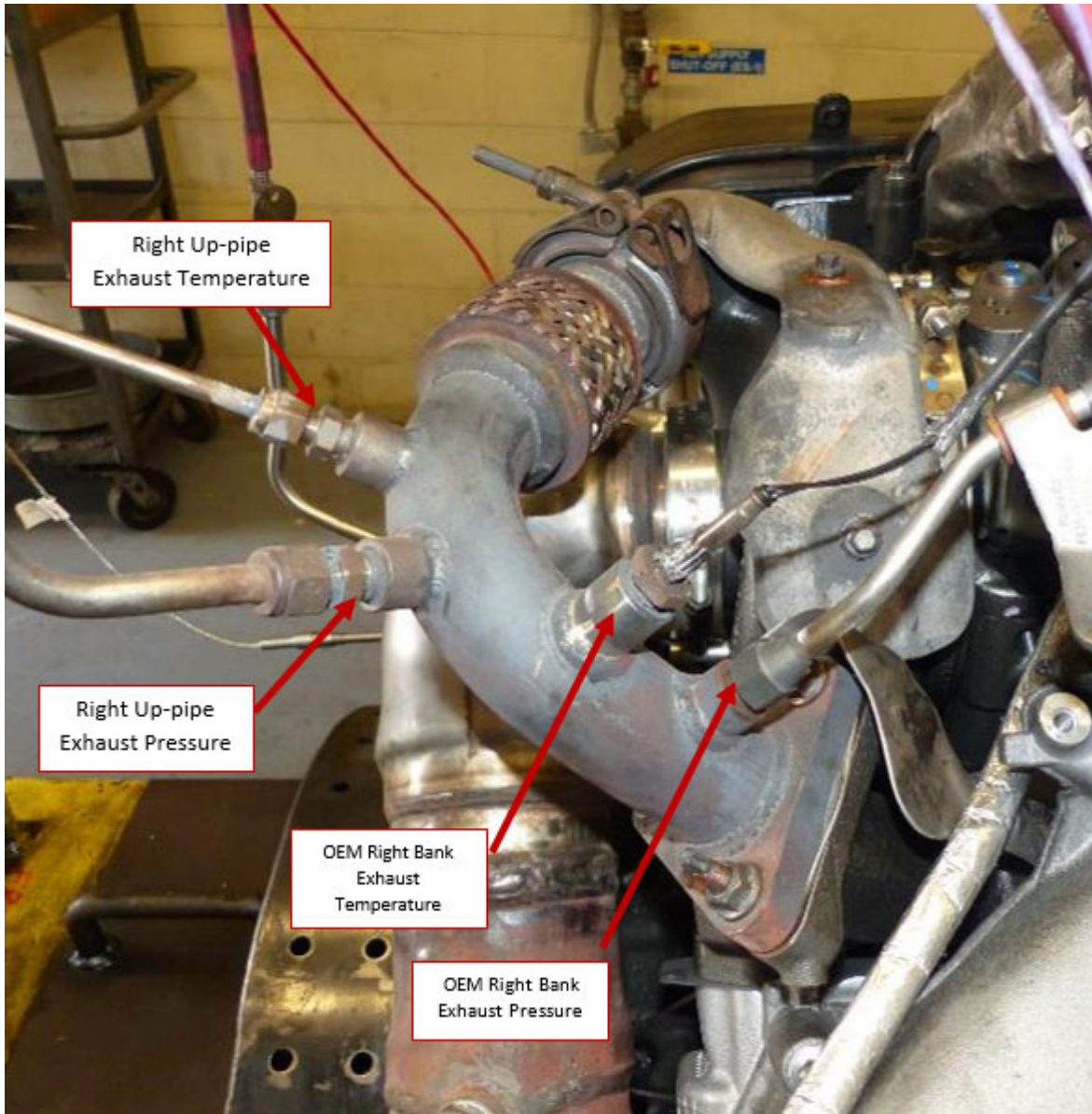

Figure A4.26 Example Right Exhaust Up-Pipe Sensor Locations

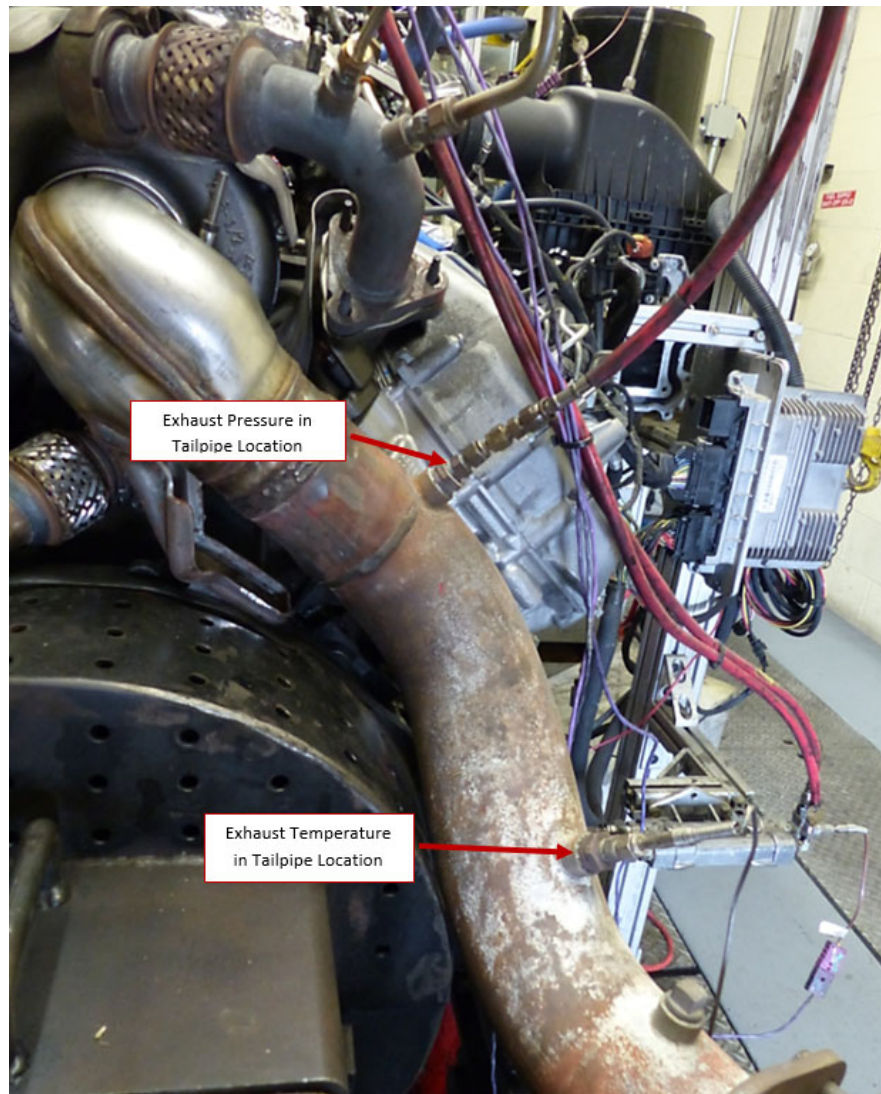

Figure A4.27 Exhaust Pressure and Temperature Sensor Locations



Figure A4.28 Engine Coolant-Outlet Thermocouple Location

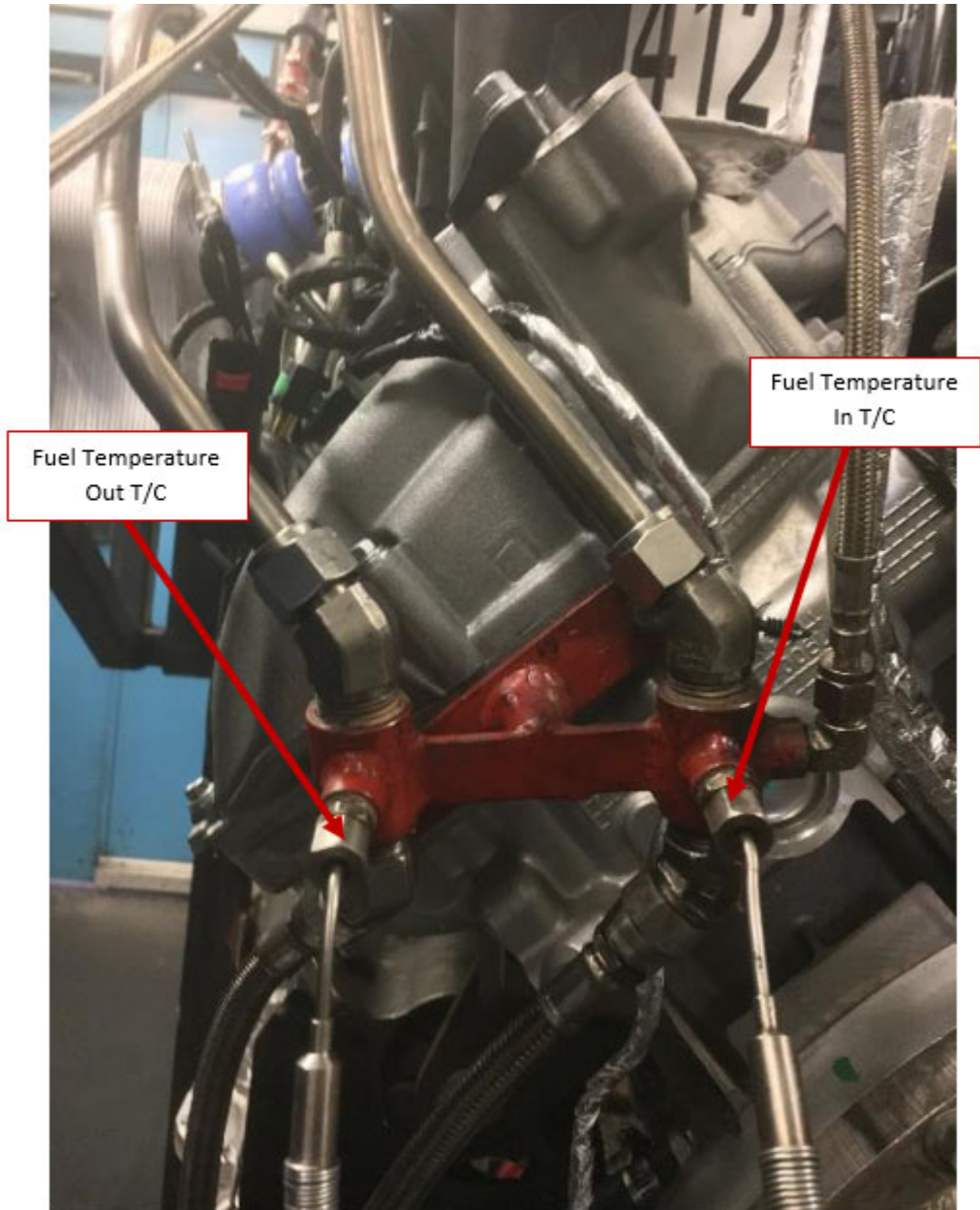

Figure A4.29 Fuel Thermocouple Locations

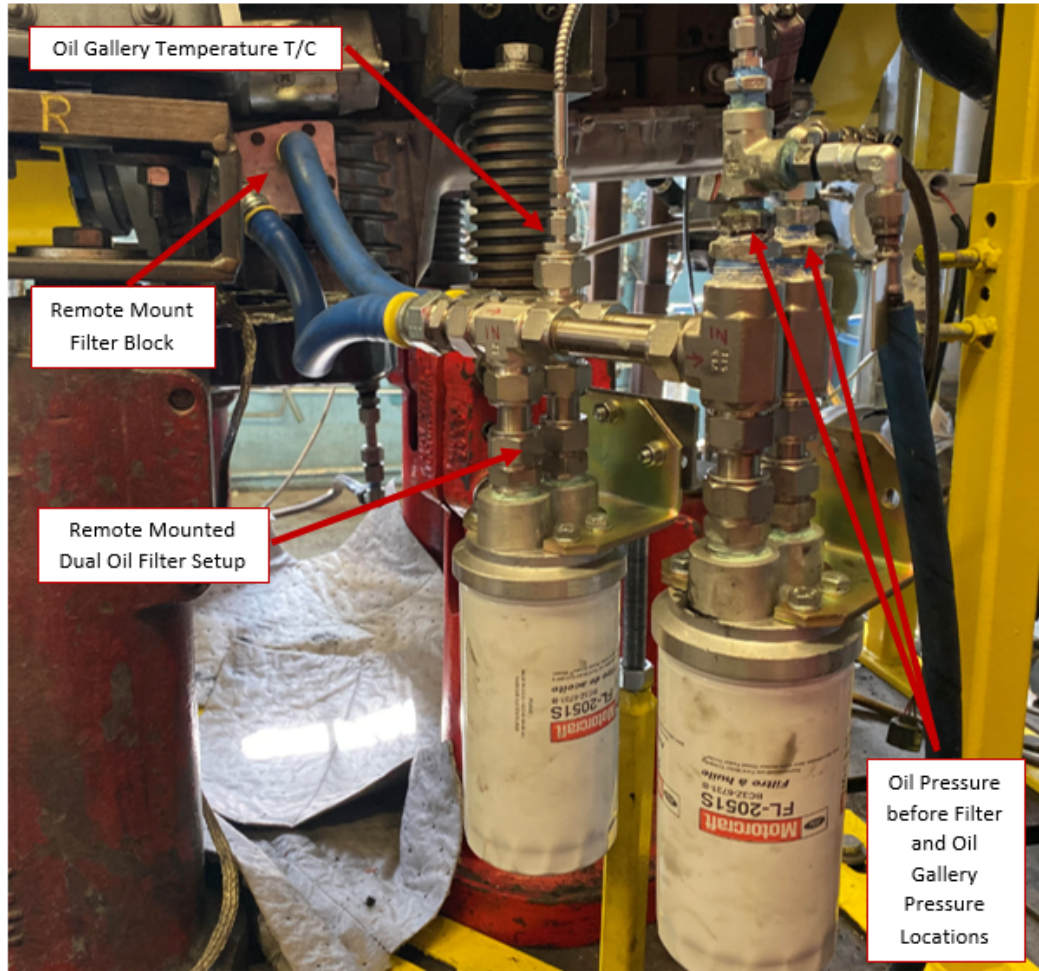
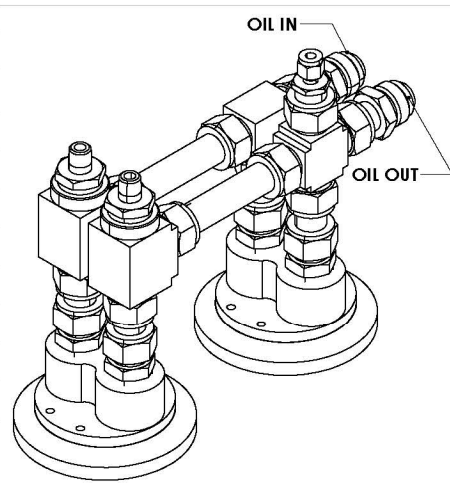

Figure A4.30 Remote Mounted Oil Filter Setup with Oil Gallery Temperature and Pressure Locations

ITEM NO.	PART NUMBER	DESCRIPTION	QTY.
1	WGS Remote Filter Head	P/N: 149-0001-01	2
2	SS-12-TA-1-12AN	AN ADAPTER, 3/4 PORT TO 3/4 AN	2
3	SS-1210-1-12	MALE CONNECTOR, 3/4 NPT TO TUBE	4
4	SS-1210-3TFT	FEMALE RUN TEE, 3/4	2
5	SS-1210-3	UNION TEE, 3/4	1
6	SS-1210-4	UNION CROSS, 3/4	1
7	SS-1211-PC	PORT CONNECTOR, 3/4	4
8	SS TUBE	3/4 SS TUBE	2
9	SS-12-HRN-4	HEX REDUCING NIPPLE, 3/4 TO 1/4	2
10	SS-400-R-12	REDUCER 3/4 TUBE TO 1/4 TUBE	1

*AN -12 LINES AND FITTINGS TO BE USED FROM THE FILTER ASSEMBLY TO THE ENGINE REMOTE OIL FILTER ADAPTER PLATE. USE STAINLESS STEEL FITTINGS ONLY.



EXPLODED VIEW

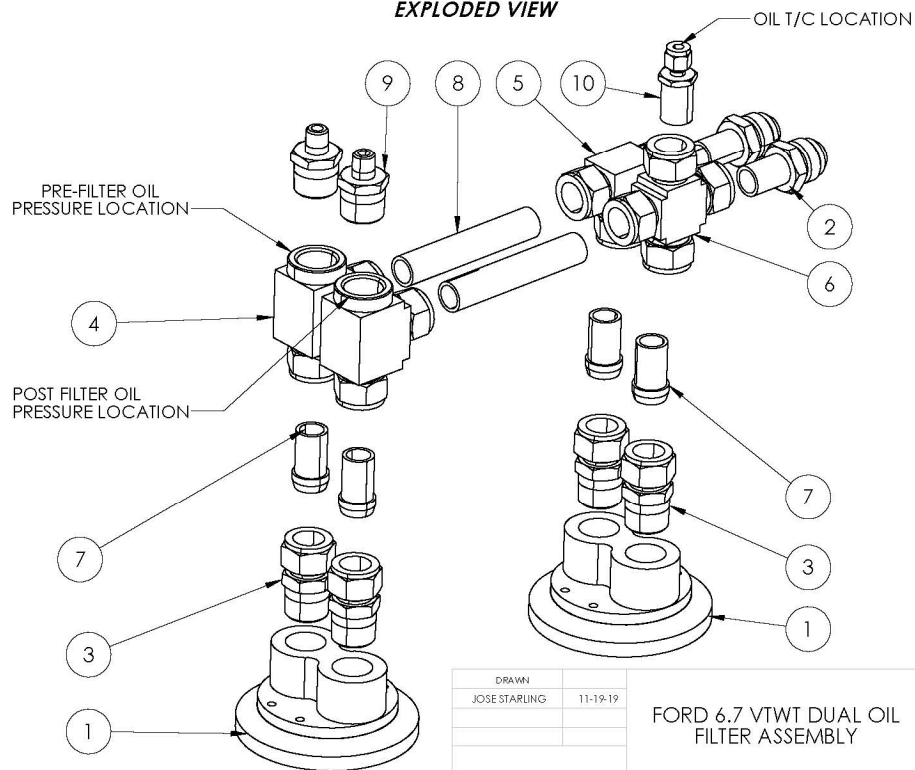

*ITEM NUMBER 9 CAN BE ADJUSTED TO FIT APPROPRIATE PRESSURE LINE TYPE.

DRAWN			
JOSE STARLING	11-19-19		
FORD 6.7 VTWT DUAL OIL FILTER ASSEMBLY			
SIZE	DWG. NO.	REV.	
A	FVTWT-OFA-1	2	
SCALE: 1:1	WEIGHT:	SHEET 1 OF 1	

Figure A4.31 Dual Oil Filter Assembly Detail

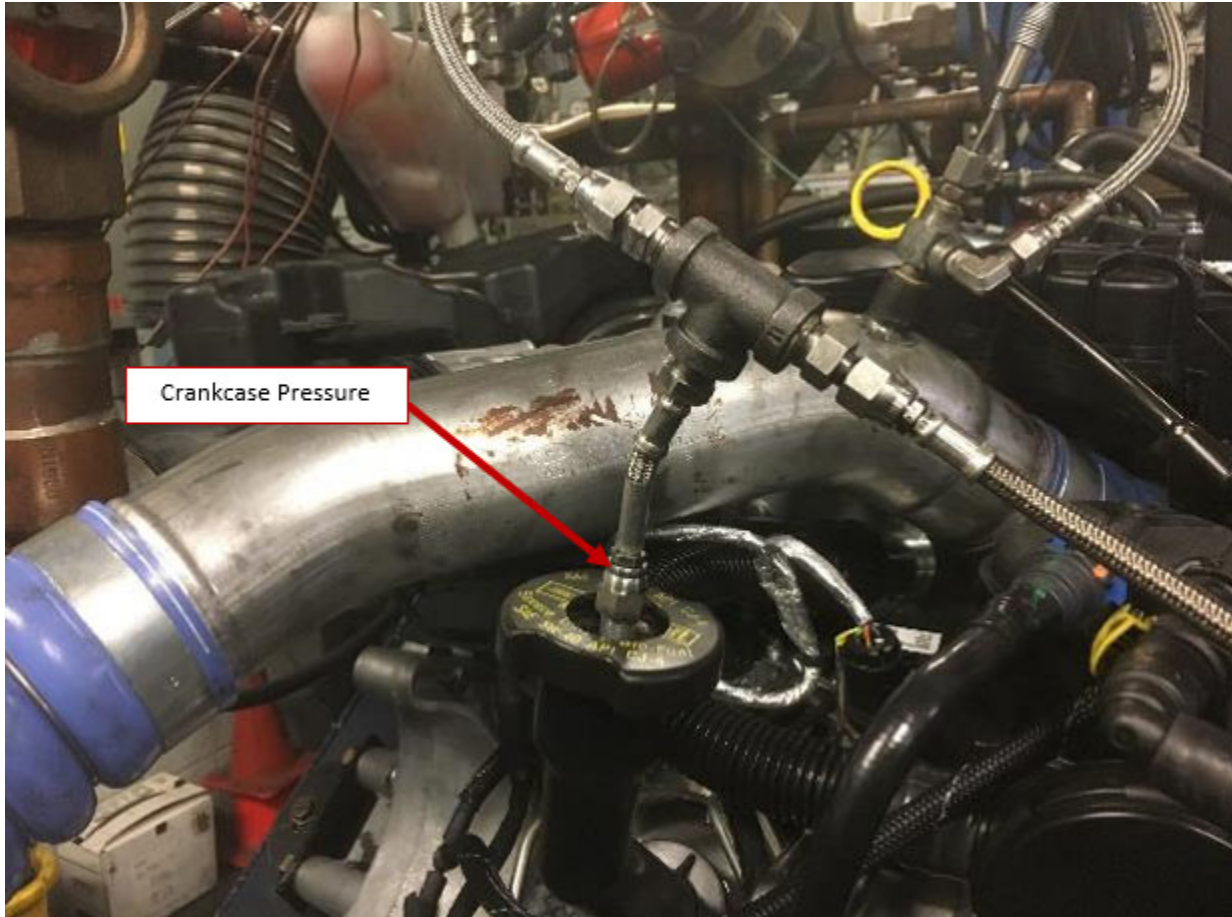

Figure A4.32 Crankcase Pressure Measurement Location



Figure A4.33 Example of Auxiliary Oil Reservoir Suspended from a Load Cell

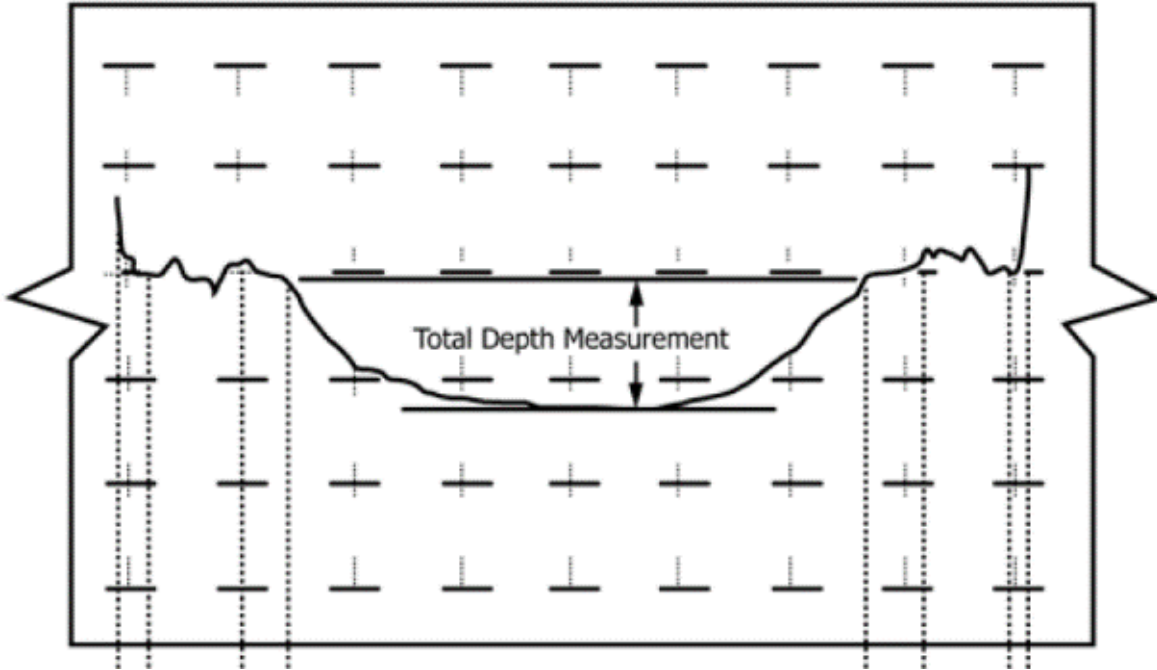
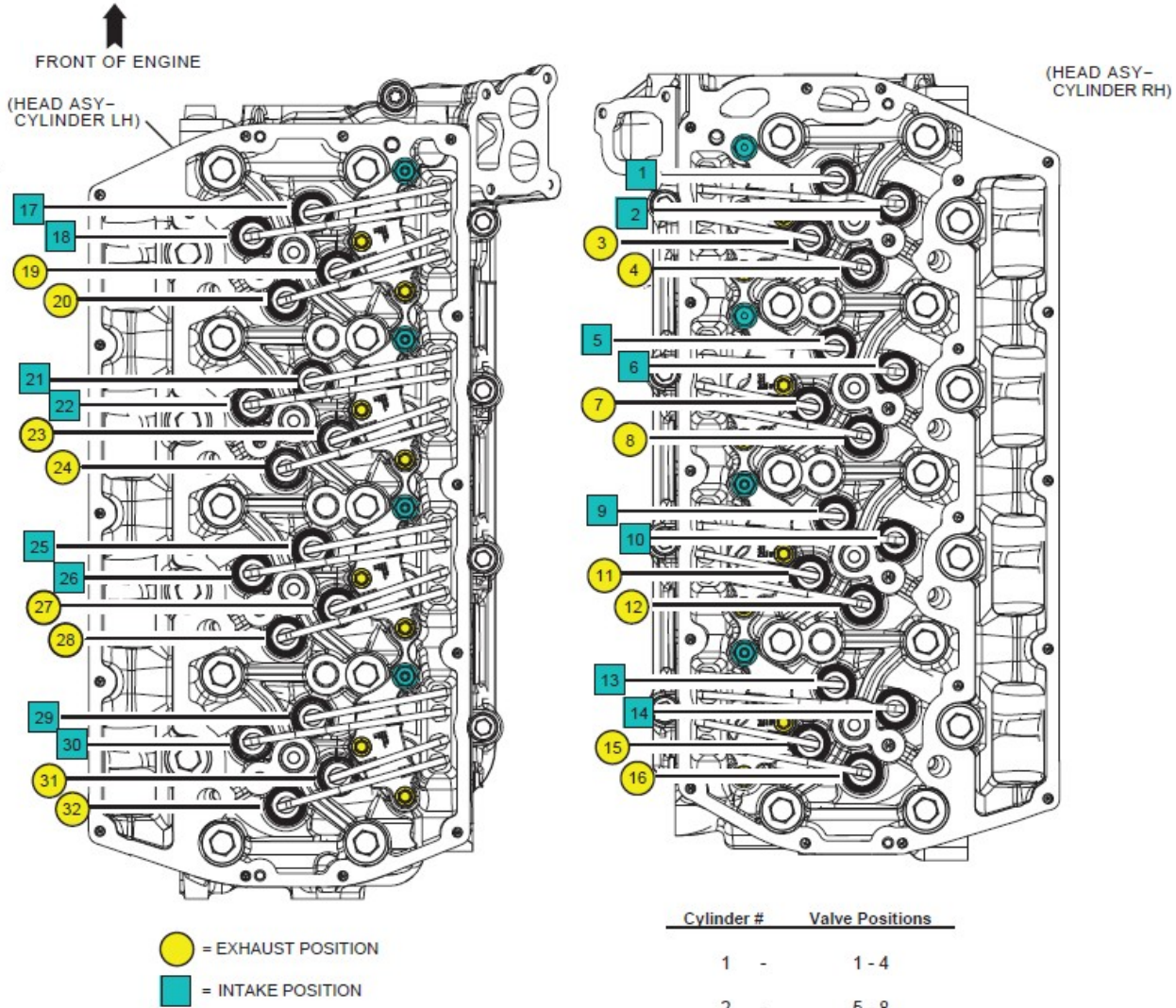

Figure A4-34 Shaft Wear Depth Example

Valve Train Wear Testing Location Information



Cylinder #	Valve Positions
1 -	1 - 4
2 -	5 - 8
3 -	9 - 12
4 -	13 - 16
5 -	17 - 20
6 -	21 - 24
7 -	25 - 28
8 -	29 - 32

Figure A4-35 Valvetrain Location Information

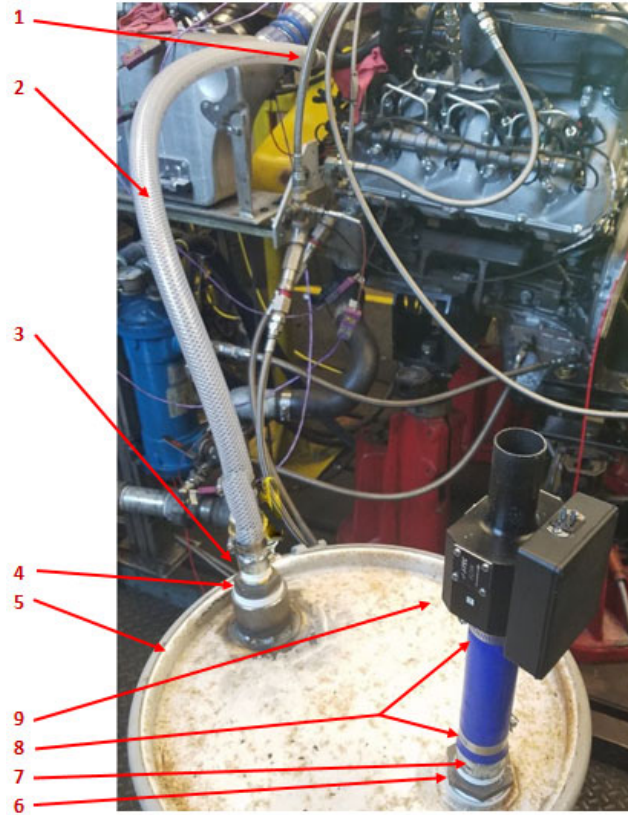

ITEM #	ITEM	DESCRIPTION
1	HOSE BARB	1" X 1" Hose barb with 2 hose clamps to hold tube and hose in place
2	TYGON HOSE	1" ID reinforced Tygon hose, approximately 5' must have downward slope
3	NIPPLE	1" Close Nipple to attach Tygon hose to barrel using micromesh screw clamp
4	BUSHING	2" to 1" reducing bushing
Note:	May use 1" to 1.25" ID Tygon hose for items 1 - 4 with appropriate fittings	
5	DRUM	5 Gallon minimum size
6	BUSHING	2" TO 1.5" reducing bushing
7	BARB	1.5" TO 1.5" Hose barb or nipple
8	HOSE	1.5" ID Silicon hose, 8" (inch) length with 2 hose clamps
9	METER	J-TEC Model #VF563 Blowby Meter

Figure A4.36 Typical Blowby Surge Tank & J-Tec Meter

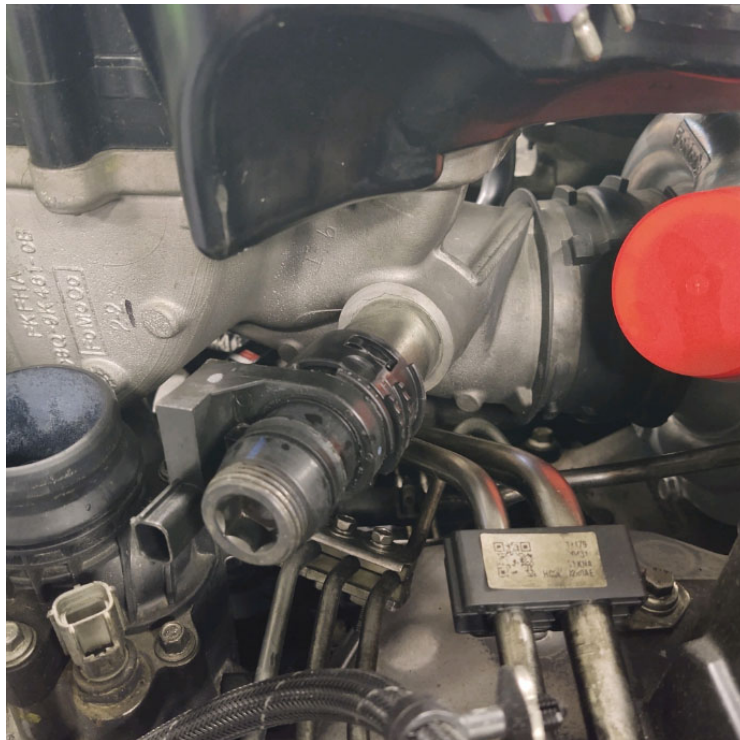

Figure A4.37 Oil Mist Separator Connection Block-Off

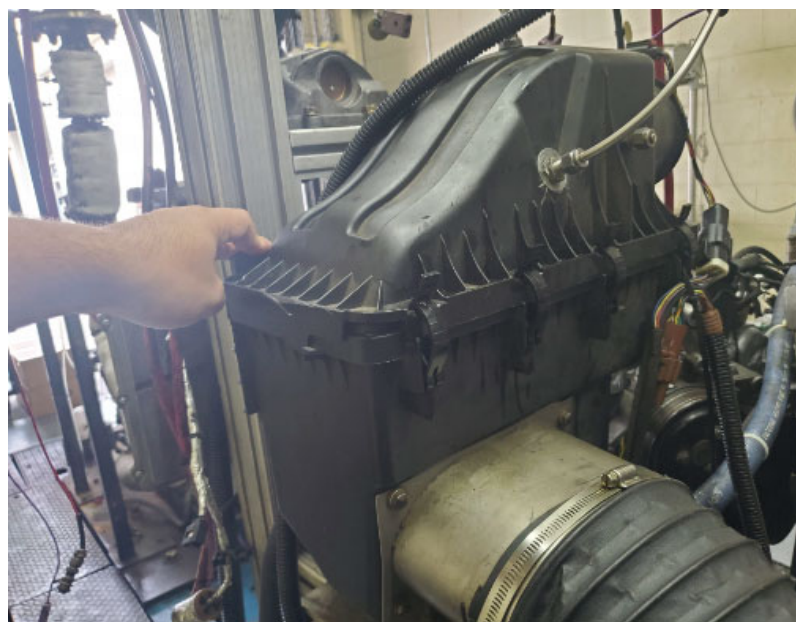

Figure A4.38 Modified Production Air Box



Figure A4.39 Production Air Filter Element With or Without Element Paper



Figure A4.40 External Foam Filter Element

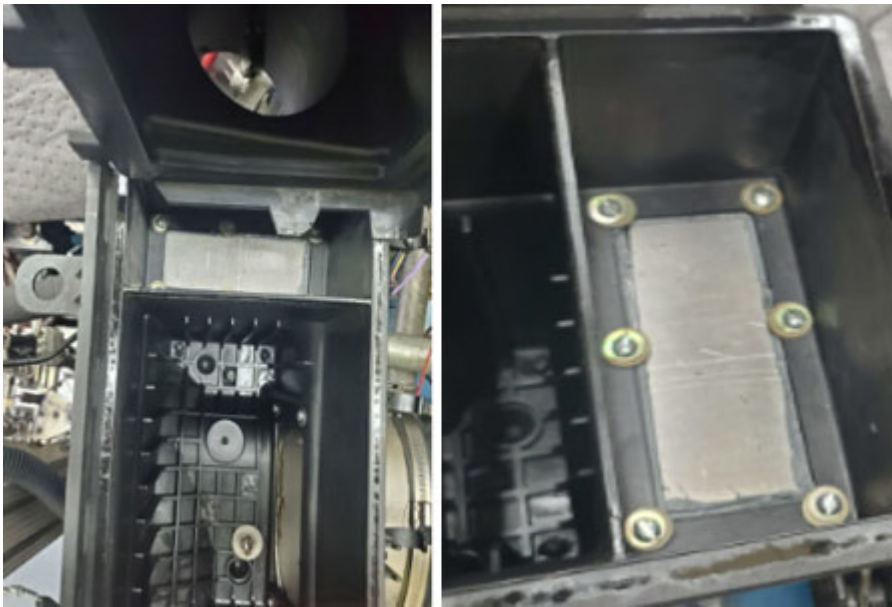

Figure A4.41 Alternate Air Inlet Blocked and Sealed

A5. FUEL SPECIFICATION

The Test Fuel specification is available from the ASTM Test Monitoring Center website

<https://www.astmtmc.org/ftp/docs/fuel/tmc-monitored%20test%20fuel%20specifications.pdf>

A6. BREAK-IN, START-UP, SHUTDOWN, TRANSITION, AND TEST PROCEDURES

A6.1 Use the sequence in **TABLE A6.1** for the pretest flushes.

A6.2 Use the sequence in **TABLE A6.2** for the pretest break-in.

A6.3 Use the sequence in **TABLE A6.10** for the engine power check.

A6.4 Use the sequence in **TABLE A6.8** for initial engine startup and subsequent startups during the Wear Phase.

A6.6 Use the sequence shown in **TABLE A6.7** for a normal shutdown.

TABLE A6.1 Oil Flush Conditions

A6.1 Oil Flush Setpoints													
	Time	Setpoint Ramp	Engine Speed	Air Pressure in CAC Coolant System	Air Pressure in Engine Coolant System	Air Pressure in Engine Intake	Air Temperature at CAC Outlet	Air Temperature in Engine Intake	Engine Coolant Outlet Temperature	Engine Torque	Exhaust Pressure in Tailpipe	Fuel Temperature at Engine Inlet	Oil Temperature in Engine Oil Gallery
Step	h:min	Time,s	r/min	kPa(G)	kPa(G)	kPa(A)	°C	°C	°C	Nm	kPa(A)	°C	°C
1 ^A			650	34	124	95	45	30	60	0	97.5	35	109
2 ^B	0:15	10	1000	34	124	95	45	25	90.5	0	97.5	35	109

^A Consider setpoints as maximums for idle conditions

^B Consider setpoints as maximums for flush conditions

TABLE A6.2 Break-In Sequence

A6.2 Break-In Setpoints													
	Time	Setpoint Ramp	Engine Speed	Air Pressure in CAC Coolant System	Air Pressure in Engine Coolant System	Air Pressure in Engine Intake	Air Temperature at CAC Outlet	Air Temperature in Engine Intake	Engine Coolant Outlet Temperature	Engine Torque	Exhaust Pressure in Tailpipe	Fuel Temperature at Engine Inlet	Oil Temperature in Engine Oil Gallery
Step ^A	h:min	Time,s	r/min	kPa(G)	kPa(G)	kPa(A)	°C	°C	°C	Nm	kPa(A)	°C	°C
1	0:06	10	650	34	131	97	45	25	90.5	54	97.5	35	109
2	0:06	10	1000	34	131	96.75	45	25	90.5	125	97.5	35	109
3	0:30	30	1200	34	131	96.5	45	25	90.5	180	97.5	35	109
4	0:30	30	1400	34	131	95.75	45	25	90.5	244	97.5	35	109
5	0:30	30	1500	34	131	95.25	45	25	90.5	281	98	35	109
6	0:30	30	1600	34	131	95	45	25	90.5	320	98.5	35	109
7	0:30	60	1700	34	131	95	45	25	90.5	362	99	35	109
8	0:30	60	1800	34	131	95	45	25	90.5	404	100	35	109
9	0:30	60	2000	34	131	95	45	25	90.5	499	103	35	109
10	0:30	120	2200	34	131	95	45	25	90.5	620	110	35	109
11	0:30	120	2400	34	131	95	45	25	90.5	717	120	35	109
12	0:30	120	2500	34	131	95	45	25	90.5	781	127	35	109
13	0:30	120	2600	34	131	95	45	25	90.5	843	135	35	109
14	0:30	120	2700	34	131	95	45	25	90.5	910	142	35	109
15	0:54	120	2800	34	131	95	45	25	90.5	979	154	35	109

^A Temperatures and pressures may not reach setpoint during conditions; however, all test operations shall be targeted at setpoints.

TABLE A6.3 Break-in Startup Sequence for Steps 1-7

A6.3 Break-in Startup Sequence for Steps 1-7

	Time	Setpoint Ramp	Engine Speed	Air Pressure in CAC Coolant System	Air Pressure in Engine Coolant System	Air Pressure in Engine Intake	Air Temperature at CAC Outlet	Air Temperature in Engine Intake	Engine Coolant Outlet Temperature	Engine Torque	Exhaust Pressure in Tailpipe	Fuel Temperature at Engine Inlet	Oil Temperature in Engine Oil Gallery
Step	h:min	Time,s	r/min	kPa(G)	kPa(G)	kPa(A)	°C	°C	°C	Nm	kPa(A)	°C	°C
1 ^A			650	34	124	95	45	30	60	0	97.5	35	109
1 ^C	0:05	s	s	s	s	s	s	s	s	s	s	s	s

^A Consider setpoints as maximums for idle conditions.

^B Run break-in conditions that were aborted for specified time, refer to Table A6.2 for setpoints.

^C Temperatures and pressures may not reach setpoint during conditions; however, all test operations shall be targeted at setpoints.

TABLE A6.4 Break-In Startup Sequence for Steps 8-9

A6.4 Break-in Startup Sequence for Steps 8 - 9

	Time	Setpoint Ramp	Engine Speed	Air Pressure in CAC Coolant System	Air Pressure in Engine Coolant System	Air Pressure in Engine Intake	Air Temperature at CAC Outlet	Air Temperature in Engine Intake	Engine Coolant Outlet Temperature	Engine Torque	Exhaust Pressure in Tailpipe	Fuel Temperature at Engine Inlet	Oil Temperature in Engine Oil Gallery
Step	h:min	Time,s	r/min	kPa(G)	kPa(G)	kPa(A)	°C	°C	°C	Nm	kPa(A)	°C	°C
1 ^A			650	34	124	95	45	30	60	0	97.5	35	109
2 ^C	0:05	60	1200	34	131	96	45	25	90.5	400	97.5	35	109
3 ^C	0:05	s	s	s	s	s	s	s	s	s	s	s	s

^A Consider setpoints as maximums for idle conditions.

^B Run break-in conditions that were aborted for specified time, refer to Table A6.2 for setpoints.

^C Temperatures and pressures may not reach setpoint during conditions; however, all test operations shall be targeted at setpoints.

TABLE A6.5 Break-in Startup Sequence for Steps 10-12

A6.5 Break-in Startup Sequence for Steps 10 - 12

	Time	Setpoint Ramp	Engine Speed	Air Pressure in CAC Coolant System	Air Pressure in Engine Coolant System	Air Pressure in Engine Intake	Air Temperature at CAC Outlet	Air Temperature in Engine Intake	Engine Coolant Outlet Temperature	Engine Torque	Exhaust Pressure in Tailpipe	Fuel Temperature at Engine Inlet	Oil Temperature in Engine Oil Gallery
Step	h:min	Time,s	r/min	kPa(G)	kPa(G)	kPa(A)	°C	°C	°C	Nm	kPa(A)	°C	°C
1 ^A			650	34	124	95	45	30	60	0	97.5	35	109
2 ^D	0:05	60	1200	34	131	96	45	25	90.5	400	97.5	35	109
3 ^D	0:05	60 ^B	1600	34	131	95	45	25	90.5	600	102	35	109
4 ^D	0:05	c	c	c	c	c	c	c	c	c	c	c	c

^A Consider setpoints as maximums for idle conditions.

^B Setpoint ramp for exhaust pressure in tailpipe is 75s.

^C Run break-in conditions that were aborted for specified time, refer to Table A6.2 for setpoints.

^D Temperatures and pressures may not reach setpoint during conditions; however, all test operations shall be targeted at setpoints.

TABLE A6.6 Break-in Startup Sequence for Steps 13-15

A6.6 Break-in Startup Sequence for Steps 13 - 15

	Time	Setpoint Ramp	Engine Speed	Air Pressure in CAC Coolant System	Air Pressure in Engine Coolant System	Air Pressure in Engine Intake	Air Temperature at CAC Outlet	Air Temperature in Engine Intake	Engine Coolant Outlet Temperature	Engine Torque	Exhaust Pressure in Tailpipe	Fuel Temperature at Engine Inlet	Oil Temperature in Engine Oil Gallery
Step	h:min	Time,s	r/min	kPa(G)	kPa(G)	kPa(A)	°C	°C	°C	Nm	kPa(A)	°C	°C
1 ^A			650	34	124	95	45	30	60	0	97.5	35	109
2 ^D	0:05	60	1200	34	131	96	45	25	90.5	400	97.5	35	109
3 ^D	0:05	60 ^B	1600	34	131	95	45	25	90.5	600	102	35	109
4 ^D	0:05	60 ^B	2000	34	131	95	45	25	90.5	800	122	35	109
5 ^D	0:05	c	c	c	c	c	c	c	c	c	c	c	c

^A Consider setpoints as maximums for idle conditions.

^B Setpoint ramp for exhaust pressure in tailpipe is 75s.

^C Run break-in conditions that were aborted for specified time, refer to Table A6.2 for setpoints.

^D Temperatures and pressures may not reach setpoint during conditions; however, all test operations shall be targeted at setpoints.

TABLE A6.7 Normal Shutdown Sequence

A6.7 Normal Shutdown Sequence setpoints

	Time	Setpoint Ramp	Engine Speed	Air Pressure in CAC Coolant System	Air Pressure in Engine Coolant System	Air Pressure in Engine Intake	Air Temperature at CAC Outlet	Air Temperature in Engine Intake	Engine Coolant Outlet Temperature	Engine Torque	Exhaust Pressure in Tailpipe	Fuel Temperature at Engine Inlet	Oil Temperature in Engine Oil Gallery
Step	h:min	Time,s	r/min	kPa(G)	kPa(G)	kPa(A)	°C	°C	°C	Nm	kPa(A)	°C	°C
1	0:02	120 ^{A,B}	650	34	124	95	45	25	60	0	97.5	35	109

^A Setpoint ramp time for engine torque is 60s.

^B Setpoint ramp time for engine speed is 100s after a 20s delay.

TABLE A6.8 Wear Phase Startup Sequence

A6.8 Wear Phase Startup Sequence Setpoints

	Time	Setpoint Ramp	Engine Speed	Air Pressure in CAC Coolant System	Air Pressure in Engine Coolant System	Air Pressure in Engine Intake	Air Temperature at CAC Outlet	Air Temperature in Engine Intake	Engine Coolant Outlet Temperature	Engine Torque	Exhaust Pressure in Tailpipe	Fuel Flow Rate	Fuel Temperature at Engine Inlet	Oil Temperature in Engine Oil Gallery
Step	h:min	Time,s	r/min	kPa(G)	kPa(G)	kPa(A)	°C	°C	°C	Nm	kPa(A)	kg/hr	°C	°C
1 ^A			650	34	124	95	45	30	60	0	97.5		35	109
2 ^D	0:05	60	1200	34	131	96	45	25	90.5	400	97.5		35	109
3 ^D	0:05	60 ^B	1600	34	131	95	45	25	90.5	600	102		35	109
4 ^D	0:05	60 ^B	2000	34	131	95	45	25	90.5	800	122		35	109
5 ^D	0:03	60 ^C	2800	34	131	95	50	25	90.5	Full Accelerator W.O.T	194		35	109
6 ^D	0:02		2800	34	131	95	50	25	90.5		194	70.5	35	109

^A Consider setpoints as maximums for idle conditions.

^B Setpoint ramp for exhaust pressure in tailpipe is 75s.

^C Setpoint ramp for exhaust pressure in tailpipe follows a 15s delay

^D Temperatures and pressures may not reach setpoint during conditions; however, all test operations shall be targeted at setpoints.

TABLE A6.9 Power Check Startup Sequence

A6.9 Power Check Startup Sequence Setpoints

	Time	Setpoint Ramp	Engine Speed	Air Pressure in CAC Coolant System	Air Pressure in Engine Coolant System	Air Pressure in Engine Intake	Air Temperature at CAC Outlet	Air Temperature in Engine Intake	Engine Coolant Outlet Temperature	Engine Torque	Exhaust Pressure in Tailpipe	Fuel Temperature at Engine Inlet	Oil Temperature in Engine Oil Gallery
Step	h:min	Time,s	r/min	kPa(G)	kPa(G)	kPa(A)	°C	°C	°C	Nm	kPa(A)	°C	°C
1 ^A			650	34	124	95	45	30	60	0	97.5	35	109
2 ^D	0:05	60	1200	34	131	96	45	25	90.5	400	97.5	35	109
3 ^D	0:05	60 ^B	1600	34	131	95	45	25	90.5	600	102	35	109
4 ^D	0:05	60 ^B	2000	34	131	95	45	25	90.5	800	122	35	109
5 ^D	0:03	60 ^C	2800	34	131	95	50	25	90.5	Full Accelerator W.O.T	194	35	109

^A Consider setpoints as maximums for idle conditions.

^B Setpoint ramp for exhaust pressure in tailpipe is 75s.

^C Setpoint ramp for exhaust pressure in tailpipe follows a 15s delay

^D Temperatures and pressures may not reach setpoint during conditions; however, all test operations shall be targeted at setpoints.

TABLE A6.10 Power Check Sequence

A6.10 Power Check Sequence Setpoints

	Time	Setpoint Ramp	Engine Speed	Air Pressure in CAC Coolant System	Air Pressure in Engine Coolant System	Air Pressure in Engine Intake	Air Temperature at CAC Outlet	Air Temperature in Engine Intake	Engine Coolant Outlet Temperature	Engine Torque	Exhaust Pressure in Tailpipe	Fuel Temperature at Engine Inlet	Oil Temperature in Engine Oil Gallery
Step	h:min	Time,s	r/min	kPa(G)	kPa(G)	kPa(A)	°C	°C	°C	Nm	kPa(A)	°C	°C
1	0:05		2800	34	131	95	50	25	90.5	W.O.T. ^A	194	35	109

^A Wide Open Throttle (W.O.T.) Engine Torque is resultant.

A7. DETERMINATION OF OPERATIONAL VALIDITY

A7.1 *Quality Index Calculations:*

A7.1.1 Calculate QI for all control quantities in accordance with the DACA II Taskforce Report.²⁰ Ensure missing or bad quality data are accounted for in accordance with the DACA II Taskforce Report.²⁰

A7.1.2 Use the U and L values shown in Table 10 for the QI calculations.

A7.1.3 Round the calculated QI values to the nearest 0.001.

A7.1.4 Report the QI values on the appropriate report form.

A7.2 *Averages:*

A7.2.1 Calculate averages for all control, ranged, and non- control quantities and report the values on the appropriate report form.

A7.2.2 The averages for control and non-control quantities are not directly used to determine operational validity but they may be helpful when an engineering review is required (refer to A7.4).

A7.3 *Determining Operational Validity:*

A7.3.1 QI threshold values for operational validity are shown in Table 10.

A7.3.1.1 A test with EOT QI values for all control parameters equal to or above the threshold values and with averages for all ranged parameters within specifications is operationally valid, provided that no other operational deviations that may cause the test to be declared invalid.

A7.3.1.2 Conduct an engineering review (see A7.4) to determine the operational validity of a test with any control quantity QI value less than the threshold value.

A7.4 *Engineering Review:*

A7.4.1 Conduct an engineering review when a control quantity QI value is below the threshold value. A typical engineering review involves investigation of the test data to determine the cause of the below threshold QI. Other affected quantities may also be included in the engineering review. This can be helpful in determining if a real control problem existed and the possible extent to which it may have impacted the test. For example, a test runs with a low QI for fuel flow. An examination of the fuel flow data may show that the fuel flow data contains several over range values. At this point, an examination of exhaust temperatures may help determine whether the instrumentation problem affected real fuel flow versus affecting only the data acquisition.

7.4.2 For reference oil tests, conduct the engineering review jointly with the TMC. For non-reference oil tests, optional input is available from the TMC for the engineering review.

A7.4.3 Determine operational validity based upon the engineering review and summarize the decision in the comment section on the appropriate form. It may be helpful to include any supporting documentation at the end of the test report. The final decision regarding operational validity rests with the laboratory.

Table 10 Quality Index Values

Controlled Quantity, unit	Quality Index Threshold	Quality Index U & L Values	
		U	L
Air Pressure in Engine Intake, kPaA	0	95.5	94.5
Air Temperature at Turbo-Compressor Outlet(CAC Out), °C	0	51	49
Air Temperature in Engine Intake, °C	0	26	24
Engine Coolant-Outlet Temperature, °C	0	91.5	89.5
Engine Speed, r/min	0	2805	2795
Exhaust Pressure in Tailpipe, kPaA	0	196	192
Fuel Flow Rate, kg/hr	0	71	70
Fuel Temperature at Engine Inlet, °C	0	36	34
Oil Temperature in Engine Gallery, °C	0	110	108

A8. ASTM TMC: CALIBRATION PROCEDURES

A8.1 Reference Oils - These oils are formulated or selected to represent specific chemical, or performance levels, or both. They are usually supplied directly to a testing laboratory under code numbers to ensure that the laboratory is not influenced by prior knowledge of acceptable results in assessing test results. The TMC determines the specific reference oil the laboratory shall test.

A8.1.1 Reporting Reference-Oil Data—Test laboratories that receive reference oils for stand calibration shall submit data to the TMC on every sample of reference oil they receive. If a shipment contains any missing or damaged samples, the laboratory shall notify the TMC immediately.

A8.2 Calibration Testing:

A8.2.1 Full scale calibration testing shall be conducted at regular intervals. These full- scale tests are conducted using coded reference oils supplied by the TMC. It is a laboratory's responsibility to keep the on-site reference-oil inventory at or above the minimum level specified by the TMC test engineers.

A8.2.2 Test Stands Used for Non-Standard Tests—If a non- standard test is conducted on a previously calibrated test stand, the laboratory shall conduct a reference-oil test on that stand to demonstrate that it continues to be calibrated, prior to running standard tests.

A8.3 Reference-Oil Storage—Store under cover in locations where the ambient temperature is between $-10\text{ }^{\circ}\text{C}$ and $+50\text{ }^{\circ}\text{C}$.

A8.4 Analysis of Reference Oils—Unless specifically authorized by the TMC, do not analyze TMC reference oils, either physically or chemically. Do not resell ASTM reference oils or supply them to other laboratories without the approval of the TMC. The reference oils are supplied only for the intended purpose of obtaining calibration under the ASTM Test Monitoring System. Any unauthorized use is strictly forbidden. The testing laboratory tacitly agrees to use the TMC reference oils exclusively in accordance with the TMC's published Policies for Use and Analysis of ASTM Reference Oils, and to run and report the reference-oil test results according to TMC guide- lines. Additional policies for the use and analysis of ASTM Reference oils are available from the TMC.

A8.5 Conducting a Reference-Oil Test—When laboratory personnel are ready to run a reference calibration test, they shall request an oil code via the TMC website.

A8.6 Reporting Reference-Oil Test Results—Upon completion of the reference-oil test, the test laboratory transmits the data electronically to the TMC, as described in Section X. The TMC reviews the data and contacts the laboratory engineer to report the laboratory's calibration status. All reference-oil test results, whether aborted, invalidated, or successfully completed, shall be reported to the TMC.

A8.6.1 All deviations from the specified test method shall be reported.

A9. ASTM TEST MONITORING CENTER: MAINTENANCE ACTIVITIES

A9.1 Special Reference-Oil Tests—To ensure continuous severity and precision monitoring, calibration tests are conducted periodically throughout the year. Occasionally, the majority or even all of the industry's test stands will conduct calibration tests at roughly the same time. This could result in an unacceptably large time frame when very few calibration tests are conducted. The TMC can shorten or extend calibration periods as needed to provide a consistent flow of reference-oil test data. Adjustments to calibration periods are made such that laboratories incur no net loss or gain in calibration status.

A9.2 Special Use of the Reference-Oil Calibration System - the reference-oil system to evaluate changes that have potential impact on test severity and precision. This option is only taken when a program of donated tests is not feasible. The surveillance panel and the TMC shall develop a detailed plan for the test program. This plan requires all reference oil tests in the program to be completed as close to the same time as possible, so that no laboratory/stand calibration status is left pending for an excessive length of time. In order to maintain the integrity of the reference-oil monitoring system, each reference-oil test is conducted so as to be interpretable for stand calibration. To facilitate the required test scheduling, the surveillance panel may direct the TMC to lengthen and shorten reference-oil calibration periods within laboratories such that the laboratories incur no net loss or gain in calibration status. To ensure accurate stand, or laboratory, or both severity assessments, conduct non-reference oil tests the same as reference-oil tests.

A9.3 Donated Reference-Oil Test Programs—The surveillance panel is charged with maintaining effective reference-oil test severity and precision monitoring. During times of new parts introductions, new or re blended reference-oil additions, and procedural revisions, it may be necessary to evaluate the possible effects on severity and precision levels. The surveillance panel may choose to conduct a program of donated reference-oil tests in those laboratories participating in the monitoring system, in order to quantify the effect of a particular change on severity and precision. Typically, the surveillance panel requests its panel members to volunteer enough reference-oil test results to create a robust data set. Broad laboratory participation is needed to provide a representative sampling of the industry. To ensure the quality of the data obtained, donated tests are conducted on calibrated test stands. The surveillance panel shall arrange an appropriate number of donated tests and ensure completion of the test program in a timely manner.

A9.4 Intervals Between Reference-Oil Tests—Under special circumstances, such as extended downtime caused by industry wide parts or fuel shortages, the TMC may extend the intervals between reference-oil tests.

A9.5 Introducing New Reference Oils—Reference oils produce various results. When new reference oils are selected, participating laboratories will be requested to conduct their share of tests to enable the TMC to recommend industry test targets. ASTM surveillance panels require a minimum number of tests to establish the industry test targets for new reference oils.

A9.6 TMC Information Letters—Occasionally it is necessary to revise the test method, and notify the test laboratories of the change, prior to consideration of the revision by Subcommittee D02.B0. In such a case, the TMC issues an Information Letter. Information Letters are balloted semi-annually by Subcommittee D02.B0, and subsequently by D02. By this means, the Society due process procedures are applied to these Information Letters.

A9.6.1 Issuing Authority—The authority to issue an Information Letter differs according to its nature. In the case of an Information Letter concerning a part number change which does not affect test results, the TMC is authorized to issue such a letter. Long term studies by the surveillance panel to improve the test procedure through improved operation and hardware control may result in the issuance of an Information Letter. If obvious procedural items affecting test results need immediate attention, the test sponsor and the TMC issue an Information Letter and present the background and data supporting that action to the surveillance panel for approval prior to the semiannual Subcommittee D02.B0 meeting.

A9.7 TMC Memoranda—In addition to the Information Letters, supplementary memoranda are issued. These are developed by the TMC and distributed to the appropriate surveillance panel and participating laboratories. They convey such information as batch approvals for test parts or materials, clarification of the test procedure, notes and suggestions of the collection and analysis of special data that the TMC may request, or for any other pertinent matters having no direct effect on the test performance, results, or precision and bias.

A10. ASTM TEST MONITORING CENTER: RELATED INFORMATION

A10.1 New Laboratories—Laboratories wishing to become part of the ASTM Test Monitoring System will be requested to conduct reference-oil tests to ensure that the laboratory is using the proper testing techniques. Information concerning fees, laboratory inspection, reagents, testing practices, appropriate committee membership, and rater training can be obtained by contacting the TMC Director.

A10.2 Information Letters: COTCO Approval—Authority for the issuance of Information Letters was given by the committee on Technical Committee Operations in 1984, as follows: “COTCO recognizes that D02 has a unique and complex situation. The use of Information Letters is approved providing each letter contains a disclaimer to the effect that such has not obtained ASTM consensus. These Information Letters should be moved to such consensus as rapidly as possible.”

A10.3 Precision Data—The TMC determines the precision of test methods by analyzing results of calibration tests conducted on reference oils. Precision data are updated regularly. Current precision data can be obtained from the TMC.

ASTM International takes no position respecting the validity of any patent rights asserted in connection with any item mentioned in this standard. Users of this standard are expressly advised that determination of the validity of any such patent rights, and the risk of infringement of such rights, are entirely their own responsibility.

This standard is subject to revision at any time by the responsible technical committee and must be reviewed every five years and if not revised, either reapproved or withdrawn. Your comments are invited either for revision of this standard or for additional standards and should be addressed to ASTM International Headquarters. Your comments will receive careful consideration at a meeting of the responsible technical committee, which you may attend. If you feel that your comments have not received a fair hearing you should make your views known to the ASTM Committee on Standards, at the address shown below.

This standard is copyrighted by ASTM International, 100 Barr Harbor Drive, PO Box C700, West Conshohocken, PA 19428-2959, United States. Individual reprints (single or multiple copies) of this standard may be obtained by contacting ASTM at the above address or at 610-832-9585 (phone), 610-832-9555 (fax), or service@astm.org (e-mail); or through the ASTM website (www.astm.org). Permission rights to photocopy the standard may also be secured from the Copyright Clearance Center, 222 Rosewood Drive, Danvers, MA 01923, Tel: (978) 646-2600; <http://www.copyright.com/>