

THIS DOCUMENT IS NOT AN ASTM STANDARD; IT IS UNDER CONSIDERATION WITHIN AN ASTM TECHNICAL COMMITTEE BUT HAS NOT RECEIVED ALL APPROVALS REQUIRED TO BECOME AN ASTM STANDARD. IT SHALL NOT BE REPRODUCED OR CIRCULATED OR QUOTED, IN WHOLE OR IN PART, OUTSIDE OF ASTM COMMITTEE ACTIVITIES EXCEPT WITH THE APPROVAL OF THE CHAIRMAN OF THE COMMITTEE HAVING JURISDICTION AND THE PRESIDENT OF THE SOCIETY.

COPYRIGHT ASTM, 100 BARR HARBOR DRIVE, WEST CONSHOHOCKEN, PA 19428-2959 ALL RIGHTS RESERVED.

ASTM Designation: DXXXX – XX

Standard Test Method for Evaluation of Diesel Engine Oils in the Cummins M11 Engine with Exhaust Gas Recirculation¹

This standard is issued under the fixed designation DXXXX; the number immediately following the designation indicates the year of original adoption or, in the case of revision, the year of last revision. A number in parentheses indicates the year of last reappraisal. A superscript epsilon (ε) indicates an editorial change since the last reappraisal.

1. Scope

1.1 This test method is commonly referred to as the Cummins M11 Exhaust Gas Recirculation Test (EGR)². The test method defines a heavy-duty diesel engine test procedure to evaluate oil performance with regard to valve train wear, cylinder wear, sludge deposits, and oil filter plugging³ in an EGR environment.

1.2 The values stated in SI units are to be regarded as the standard. The values given in parenthesis are for information only.

1.3 *This standard does not purport to address all of the safety concerns, if any, associated with its use. It is the responsibility of the user of this standard to establish appropriate safety and health practices, and determine the applicability of regulatory limitations prior to use. See A1 for general safety precautions.*

1.4 Table of Contents:

Scope	1
Referenced Documents	2
Terminology	3
Summary of Test Method	4
Significance and Use	5
Apparatus	6
Test Engine Configuration	6.1
Test Engine	6.1.1
Oil Heat Exchanger, Adapter Blocks, and Block Off Plate	6.1.2
Oil Filter Head Modification	6.1.3
Oil Pan Modification	6.1.4
Engine Control Module	6.1.5
Engine Position Sensor	6.1.6
Air Compressor and Fuel Pump	6.1.7
Test Stand Configuration	6.2
Engine Mounting	6.2.1
Intake Air System	6.2.2
Aftercooler	6.2.3
Exhaust System	6.2.4
Exhaust Gas Recirculation System	6.2.5
Fuel Supply	6.2.6

Coolant System	6.2.7
Pressurized Oil Fill System	6.2.8
External Oil System	6.2.9
Crankcase Aspiration	6.2.10
Blowby Rate	6.2.11
System Time Responses	6.3
Oil Sample Containers	6.4
Mass Balance	6.5
Engine and Cleaning Fluids	7
Test Oil	7.1
Test Fuel	7.2
Engine Coolant	7.3
Solvent	7.4
Preparation of Apparatus	8
Cleaning of Parts	8.1
Crosshead Cleaning and Measurement	8.1.6
Rod Bearing Cleaning and Measurement	8.1.7
Ring Cleaning and Measurement	8.1.8
Liner Cleaning and Measurement	8.1.9
Adjusting Screw Cleaning and Measurement	8.1.10
Engine Assembly	8.2
General	8.2.1
Parts Reuse and Replacement	8.2.2
Build-Up Oil	8.2.3
Coolant Thermostat	8.2.4
Oil Thermostat	8.2.5
Fuel Injectors	8.2.6
New Parts	8.2.7
Operational Measurements	8.3
Units and Formats	8.3.1
Instrumentation Calibration	8.3.2
Temperatures	8.3.3
Pressures	8.3.4
Flow Rate	8.3.5
Engine/Stand Calibration and Non-Reference Oil Tests	9
General	9.1
New Test Stand	9.2
Stand Calibration Period	9.3
Stand Modification and Calibration Status	9.4
Test Numbering System	9.5
Reference Oil Test Acceptance	9.6
Unacceptable Reference Oil Test	9.7
Reference Oil Accountability	9.8
Non-Reference Oil Tests	9.9
Test Procedure	10
Engine Installation and Stand Connections	10.1
Coolant System Fill	10.2
Oil Fill for Break-in	10.3
Fuel Samples	10.4
Engine Warm-up	10.5
Engine Break-in	10.6
Shutdown and Maintenance	10.7
300-h Test Procedure	10.8
Oil Fill for Test	10.8.2
Zero-h Oil Sample	10.8.3.1

Operating Conditions	10.8.4
Injection Timing Change	10.8.5
%Soot Validity	10.8.6
Test Timer	10.8.7
Operational Data Acquisition	10.8.8
Oil Purge, Sample and Addition	10.8.9
Full and Drain Weight	10.8.9.2
End of Test (EOT)	10.9
Engine Disassembly	10.9.4
Calculations, Ratings and Test Validity	11
Crosshead Mass Loss	11.1
Adjusting Screw Mass Loss	11.2
Rod Bearing Mass Loss	11.3
Sludge Ratings	11.4
Piston Ratings	11.5
Oil Filter Plugging	11.6
Oil Analyses	11.7
Oil Consumption	11.8
Fuel Analyses	11.9
Ring Mass Loss	11.10
EGR % Mass and CO ₂ Probe Locations	11.11
Assessment of Operational Validity	11.12
Assessment of Test Interpretability	11.13
Test Report	12
Precision and Bias	13
Keywords	14
Annexes	
Safety Precautions	Annex A1
Mandatory Supplier List	Annex A2
Engine Build Parts Kit	Annex A3
Sensor Locations and Special Hardware	Annex A4
External Oil System	Annex A5
Fuel Specification	Annex A6
Cummins Service Publications	Annex A7
Specified Units and Formats	Annex A8
Piston Rating Locations	Annex A9
Oil Analyses	Annex A10
Oil Filter Plugging	Annex A11
Determination of Operational Validity	Annex A12
Appendixes	
Non-Mandatory Suppliers List	X1
Typical System configurations	X2

2. Referenced Documents

2.1 ASTM Standards:

D 86 Standard Test Method for Distillation of Petroleum Products⁴

D 92 Standard Test Method for Flash and Fire Points by Cleveland Open Cup⁴

D 97 Standard Test Method for Pour Point of Petroleum Products⁴

D 129 Standard Test Method for Sulfur in Petroleum Products⁴

D 130 Standard Test Method for Detection of Copper Corrosion from Petroleum Products by the Copper Strip Tarnish Test⁴

D 287 Standard Test Method for API Gravity of Crude Petroleum and Petroleum Products (Hydrometer Method)⁴

D 445 Standard Test Method for Kinematic Viscosity of Transparent and Opaque Liquids (and the Calculation of Dynamic Viscosity)⁴

D 482 Standard Test Method for Ash from Petroleum Products⁴

D 524 Standard Test Method for Ramsbottom Carbon Residue of Petroleum Products⁴

D 613 Standard Test Method for Cetane Number of Diesel Fuel Oil⁵

D 664 Standard Test Method for Acid Number of Petroleum Products by Potentiometric Titration⁴

D 1319 Standard Test Method for Hydrocarbon Types in Liquid Petroleum Products by Fluorescent Indicator Absorption⁴

D 2500 Standard Test Method for Cloud Point of Petroleum Products⁴

D 2622 Standard Test Method for Sulfur in Petroleum Products by x-ray Spectrometry⁶

D 2709 Standard Test Method for Water and Sediment in Middle Distillate Fuels by Centrifuge⁶

D 2896 Standard Test method for Base Number of Petroleum Products by Potentionmetric Perchloric Acid Titration⁶

D 4485 Specification for Performance of Engine Oils⁶

D 4737 Standard Test Method for Calculated Cetane Index by Four Variable Equation⁷

D4739 Standard Test method for Base Number Determination by Potentiometric Titration⁷

D 5185 Standard Test Method for Determination of Additive Elements, Wear Metals, and Contaminants in Used Lubricating Oils and Determination of Selected Elements in Base Oils by Inductively Coupled Plasma Atomic Emission Spectrometry (ICP-AES)⁷

D 5302 Test Method for Evaluation of Automotive Engine Oils for Inhibition of Deposit Formation and Wear in a Spark-Ignition Internal Combustion Engine Fueled with Gasoline and Operated Under Low-Temperature, Light Duty Conditions⁷

D 5844 Standard Test Method for Evaluation of Automotive Engine Oils for Inhibition of Rusting (Sequence IID)⁷

D 5967 Standard Test Method for Evaluation of Diesel Engine Oils in T-8 Diesel Engine⁷

E 29 Practice for Using Significant Digits in Test Data to Determine Conformance with Specifications⁸

E178 Standard Practice for Dealing with Outlying Observations

E 344 Terminology Relating to Thermometry in Hydrometry⁹

2.2 Coordinating Research Council:

CRC Manual No. 12¹⁰

CRC Manual No. 18 (Revised May, 1994)¹⁰

3. Terminology

3.1 Definitions:

3.1.1 *blind reference oil, n* - a reference oil, the

identity of which is unknown by the test facility.

D 5844

3.1.1.1 *Discussion* – This is a coded reference oil that is submitted by a source independent of the test facility.

3.1.2 *blowby, n* — in internal combustion engines, the combustion products and unburned air-and-fuel mixture that enter the crankcase.

D 5302

3.1.3 *calibrate, v* - to determine the indication or output of a measuring device with respect to that of a standard.

E 344

3.1.4 *heavy-duty, adj* – in internal combustion engine operation, characterized by average speeds, power output, and internal temperatures that are close to the potential maximum.

D 4485

3.1.5 *heavy-duty engine, adj* – in internal combustion engines, one that is designed to allow operation continuously at or close to its peak output.

D 4485

3.1.6 *non-reference oil, n* — any oil other than a reference oil, such as a research formulation, commercial oil or candidate oil.

D 5844

3.1.7 *non-standard test, n* – a test that is not conducted in conformance with the requirements in the standard test method; such as running in an non-calibrated test stand or using different test equipment, applying different equipment assembly procedures, or using modified operating conditions.

D 5844

3.1.8 *reference oil, n* – an oil of known performance characteristics, used as a basis for comparison.

D 4485

3.1.9 *sludge, n* — in internal combustion engines, a deposit, principally composed of insoluble resins and oxidation products from fuel combustion and the lubricant, that does not drain from engine parts but can be removed by wiping with a cloth.

D 5302

3.1.10 *wear, n* — the loss of material from, or relocation of material on, a surface.

D 5302

3.1.10.1 *Discussion* – Wear generally occurs between two surfaces moving relative to each other, and is the result of mechanical or chemical action or by a combination of mechanical and chemical actions.

3.2 *Descriptions of Terms Specific to This Standard:*

3.2.1 *crosshead, n* — an overhead component, located between the rocker arm and each intake valve and exhaust valve pair, that transfers rocker arm travel to the opening and closing of each valve pair.

3.2.1.1 *Discussion* -- Each cylinder has two crossheads, one for each pair of intake valves and exhaust valves.

3.2.2 *exhaust gas recirculation (EGR), n* - a method by which a portion of engine's exhaust is returned to its combustion chambers via its inlet system.

3.2.3 *overhead, n* – in internal combustion engines, the components of the valve train located in or above the cylinder head.

3.2.4 *overfuel, v* – an operating condition in which the fuel flow exceeds the standard production setting.

3.2.5 *valve train, n* – in internal combustion engines, the series of components such as valves, crossheads, rocker arms, push rods and camshaft, which open and close the intake and exhaust valves.

4. Summary of Test Method

4.1 This test method uses a Cummins M11 400 diesel engine, with a specially modified engine block. Test operation includes a 25-min. warm-up, a 2-h break-in, and 300 h in six 50-h stages. During stages A, C and E, the engine is operated with retarded fuel injection timing and is overfueled to generate excess soot. During stages B, D and F, the engine is operated at conditions to induce valve train wear.

4.2 Prior to each test, the engine is cleaned and assembled with new cylinder liners, pistons, piston rings and overhead valve train components. All aspects of the assembly are specified.

4.3 A forced oil drain, an oil sample and an oil addition, equivalent to an oil consumption of 0.23 g/kW-h, is performed at the end of each 25-h period.

4.4 The test stand is equipped with the appropriate instrumentation to control engine speed, fuel flow, and other operating parameters.

4.5 Oil performance is determined by assessing crosshead wear at 8.5% soot, top ring wear, sludge deposits and oil filter plugging.

5. Significance and Use

5.1 This test method was developed to assess the performance of a heavy-duty engine oil to control engine wear and deposits under operating conditions selected to accelerate soot production, valve train wear, and deposit formation in a turbo-charged and intercooled four-cycle diesel engine equipped with exhaust gas recirculation hardware.

5.2 The design of the engine used in this test method is representative of many, but not all, modern diesel engines. This factor, along with the accelerated operating conditions shall be

considered when extrapolating test results.

6. Apparatus

6.1 Test Engine Configuration:

6.1.1 *Test Engine* -- The Cummins M11 400 is an in-line six-cylinder heavy-duty diesel engine with 11 L of displacement and is turbocharged, aftercooled, has an overhead valve configuration and EGR hardware. It features a 1994 emissions configuration with electronic control of fuel metering and fuel injection timing. Obtain the test engine and the engine build parts kit from the supplier listed in A2.2. The components of the engine build parts kit are shown in Table A3.1.

6.1.2 *Oil Heat Exchanger, Adapter Blocks, and Block-off Plate* — The oil heat exchanger is relocated from the stock position with the use of adapter blocks as shown in Fig. A4.1. Install an oil cooler block-off plate on the back of the coolant thermostat housing as shown in Fig. A4.1. The adapter blocks can be obtained from the supplier listed in X1.3. Control the oil temperature by directing engine coolant through the oil heat exchanger (Fig A4.2).

6.1.3 *Oil Filter Head Modification* – Modify the oil filter head by plugging the filter bypass return to sump line and the engine oil thermostat (Fig A4.8). The thermostat passage should be blocked to route all of the engine oil into the oil cooler.

6.1.4 *Oil Pan Modification* — Modify the oil pan as shown in Fig. A4.3. A modified oil pan can be obtained from the supplier listed in X1.3.

6.1.5 *Engine Control Module (ECM)* — Obtain the ECM from the supplier listed in A2.2. The ECM programming has been modified to provide overfueling and retarded injection timing to increase soot generation and overhead wear. The de-rate protocols have been disabled, however the de-rate messages will still be displayed when using Cummins electronic service tools.

6.1.6 *Engine Position Sensor* – The engine position sensor has two measurement coils. The secondary coil must be disabled by cutting the two external, outside wires colored red and black. The wires are also labeled A and D on the engine position sensor plug. (Fig A4.15)

6.1.6 *Air Compressor and Fuel Pump* -- The engine-mounted air compressor is not used for this test method. Remove the air compressor and install the fuel injection pump in its place (Fig. A4.4). The fuel injection pump is driven with Cummins coupling P/N 208755. The coupling can be obtained from the supplier listed in X1.1.

6.2 Test Stand Configuration:

6.2.1 *Engine Mounting* — Install the engine so that it is upright and the crankshaft is horizontal.

6.2.1.1 *Discussion* - The engine mounting hardware should be configured to minimize block distortion when the engine is fastened to the mounts. Excessive block distortion can influence test results.

6.2.2 *Intake Air System*— With the exception of the air filter and the intake air tube, the intake air system is not specified. A typical configuration is shown in Fig. X2.1. The air filter shall have a minimum initial efficiency rating of 99.2%. Install the intake air tube (Fig A4.5) at the intake of the turbocharger compressor. Construct the system to minimize airflow restriction. To control intake manifold pressure a restriction plate or valve may be used after the aftercooler and before the inlet air tubing. A method to cool the intake air is required.

6.2.2.1 *Discussion* - Difficulty in achieving or maintaining intake manifold pressure or intake manifold temperature, or both, could be indicative of insufficient or excessive restriction.

6.2.3 *Aftercooler* – A Modine aftercooler, P/N 1A012865, will be used for aftercooling. The aftercoolers can be obtained from the supplier listed in X.1.5.

6.2.4 *Exhaust System* – Install the exhaust tube (Fig A4.6) at the discharge flange of the turbocharger turbine housing. The piping downstream of the exhaust tube is not specified. A method to control exhaust pressure is required.

6.2.5 *Exhaust Gas Recirculation System* -- The set-up components for the exhaust gas recirculation system (Fig A4.10) can be obtained from the supplier listed in X.1.2.

6.2.6 *Fuel Supply* – The fuel supply and filtration system is not specified. A typical configuration is shown in Fig. X2.2. The fuel consumption rate is determined by measuring the rate of fuel flowing into the day tank. A method to control the fuel temperature is required.

6.2.7 *Coolant System* – The system configuration is not specified. A typical configuration consists of a non-ferrous core heat exchanger, a reservoir (expansion tank) and a temperature control valve as shown in Fig. X2.3. Pressurize the system by regulating air pressure at the top of the expansion tank. The system should have a sight glass to detect air entrapment.

6.2.7.1 *Discussion* - Although the system volume is not specified, an excessively large volume can increase the time required for the engine fluid temperatures to attain specification. A system volume of 45 L or less (including engine) has proven satisfactory.

6.2.8 *Pressurized Oil Fill System* – The oil fill system is not specified. A typical configuration

includes an electric pump, a 50-L reservoir, and transfer hose. The location for pressurized fill is located on the filter head (Fig A4.8)

6.2.9 *External Oil System* — Configure the external oil system according to Fig. A5.1. The external reservoir shall be Moroso P/N 22660, which can be obtained from the supplier listed in X1.4.

6.2.9.1 *Oil Sample Valve Location* - The oil sample valve shall be located on the return line from the external oil system to the engine. It is recommended that the valve be located as close to the return pump as possible (Fig. A5.1).

6.2.9.1.1 *Discussion* - Brass or copper fittings can influence used oil wear metals analyses and shall not be used in the external oil system.

6.2.10 *Crankcase Aspiration* – Vent the blowby gas at the port located on the left side of the valve cover. The vent line shall proceed downward from the valve cover port to the blowby canister and be of a length between 1.2 and 1.8 meters and of a diameter of 1.588 cm.

6.2.11 *Blowby Rate* — The flowrate device is not specified. The blowby canister shall be 37.88 L in volume. The outlet of the blowby canister to the flowrate device shall be 3.18 cm in diameter. The hose connecting the blowby canister to the flowrate device shall be 3.81 cm in diameter the length of which is not specified.

6.3 *System Time Responses* – The maximum allowable system time responses are shown in Table 1. Determine system time responses in accordance with the Data Acquisition and Control Automation II (DACA II) Task Force Report¹².

6.4 *Oil Sample Containers* — High-density polyethylene containers are recommended for oil samples.

6.4.1 *Discussion* — Glass containers may break and may cause injury or exposure to hazardous materials, or both.

6.5 *Mass Balance* — A balance is required to measure the mass of the crossheads and rod bearings. An electronic or mechanical balance may be utilized. The balance shall have a minimum indication resolution of 0.1 mg.

7. Engine and Cleaning Fluids

7.1 *Test Oil* -- Approximately 115 L of test oil is required to complete the test.

7.2 *Test Fuel* -- Approximately 20,000 L of diesel fuel is required to complete the test. Purchase the fuel from the supplier listed in A2.1. The fuel shall have the properties and tolerances shown in A6.

7.3 *Engine Coolant* – Use pre-mixed Fleetguard Compleat PG. The coolant can be

obtained from the supplier listed in X1.1.

7.4 *Solvent* – Aliphatic naphtha or equivalent.

7.4.1 *Discussion* – Use adequate safety precautions with all solvents and cleaners.

8. Preparation of Apparatus

8.1 *Cleaning of Parts:*

8.1.1 *General* – The preparation of test engine components specific to the Cummins M11 EGR test are indicated in this section. Use the Cummins service publications¹³ listed in A7 for the preparation of other engine components. Take precautions to prevent rusting of iron components.

8.1.2 *Engine Block* – Disassemble the engine - including removal of the crankshaft, camshaft, piston cooling tubes, oil pump, oil gallery plugs – and thoroughly clean the surfaces and oil passages (galleries). It is recommended that the oil passages be cleaned with a brush. Removal of camshaft bearings is at the discretion of the laboratory.

8.1.3 *Cylinder Head* – Disassemble and clean the cylinder head. Use a brush as necessary to remove deposits.

8.1.4 *Rocker Cover and Oil Pan* – Clean the rocker cover and oil pan. Use a brush as necessary to remove deposits.

8.1.5 *External Oil System* -- Flush the internal surfaces of the oil lines and the external reservoir with solvent. Repeat until the solvent drains clean. Flush solvent through the oil pumps until the solvent drains clean.

8.1.6 *Crosshead Cleaning and Measurement*

8.1.6.1 *Handling and Orientation* - Avoid handling the crossheads with bare hands, use gloves or plastic covered tongs. Crossheads shall be oriented in the engine with the elongated slot to the exhaust valve.

8.1.6.2 Clean the crossheads with solvent. Use a non-metallic soft bristle brush if necessary.

8.1.6.3 Spray the crossheads with air until dry.

8.1.6.4 Rinse the crossheads in pentane and dry with air.

8.1.6.5 Measure crosshead mass to a tenth of a milligram (xxx.x mg).

8.1.6.6 If an electronic scale is used for mass measurement, then use the following procedure:

(a) Demagnetize (degauss) each crosshead prior to measurement

(b) Measure the crosshead twice, using two orientations 90° apart. If the difference between the two mass measurements is greater than 0.2 mg, the crosshead shall be demagnetized and the measurement process repeated.

8.1.6.7 Report the crosshead measurements on the

test report.

8.1.7 *Rod Bearing Cleaning and Measurement*

8.1.7.1 *Discussion* – Avoid handling the rod bearings with bare hands, use gloves or plastic covered tongs.

8.1.7.2 Clean the rod bearings with solvent. Use a non-metallic soft bristle brush if necessary.

8.1.7.3 Spray the rod bearings with air until dry.

Table 1 Maximum Allowable System Time Responses

Measurement Type	Time Response (s)
Speed	2.0
Temperature	3.0
Pressure	3.0
Flow	TBD

8.1.7.4 Rinse the rod bearings in pentane and dry with air.

8.1.7.5 Measure the mass of each bearing section to a tenth of a milligram (xxx.x mg).

8.1.7.6 Report the rod bearing measurements on the test report.

8.1.8 *Ring Cleaning and Measurement*

8.1.8.1 *Discussion* – Avoid handling the rod bearings with bare hands, use gloves or plastic covered tongs.

8.1.8.2 Use the procedure as stated in ASTM D 6483.

8.1.9 *Cylinder Liner Measurement*

8.1.9.1 Use the procedure as stated in ASTM D 6483.

8.1.10 *Adjusting Screw Cleaning and Measurement*

8.1.10.1 Clean the adjusting screws with solvent. Use a soft bristle brush if necessary.

8.1.10.2 Spray the adjusting screws with air until dry.

8.1.10.3 Rinse the adjusting screws with pentane and dry with air

8.1.10.2 Measure crosshead mass to a tenth of a milligram (xxx.x mg).

8.1.10.5 If an electronic scale is used for mass measurement, then use the following procedure:

(a) Demagnetize (degauss) each adjusting screw prior to measurement

(b) Measure the adjusting screw twice, using two orientations 90° apart. If the difference between the two mass measurements is greater than 0.2 mg, the adjusting screw shall be demagnetized and the measurement process repeated.

8.2 *Engine Assembly:*

8.2.1 *General* — Except as noted in this section, use the procedures indicated in the Cummins service publications (A7). Assemble the engine with the components from the Engine Build Parts Kit (A3). Other non-kit components are available from the suppliers listed in X1.1 and X1.2.

8.2.2 *Parts Reuse and Replacement* -- Engine components may be reused or replaced at the discretion of the laboratory, except as per 8.2.7.

8.2.3 *Build-Up Oil* – Use Cummins Premium Blue (X1.1) or test oil to lubricate parts for engine build. If test oil is used, then the engine build is valid only for the respective test oil.

8.2.4 *Coolant Thermostat* -- The engine coolant thermostat shall be locked open.

8.2.5 *Oil Thermostat* -- Remove the oil thermostat and plug the coolant passage. This will route all of the oil flow through the oil cooler. (Fig A4.8)

8.2.6 *Fuel Injectors* – The fuel injectors may be reused. The injectors should be dedicated to a particular cylinder. Install the injectors according to the *torque wrench method* as noted in the Cummins service publications (A7).

8.2.7 *New Parts* – The parts listed below are contained in the Engine Build Parts Kit and are not reusable (except as noted in 10.3.3). Clean the parts prior to use. Replacement of any part listed below during a test will invalidate the test.

8.2.7.1 pistons (top, skirt)

8.2.7.2 piston rings (top, second, oil)

8.2.7.3 cylinder liners

8.2.7.4 rocker lever shafts

8.2.7.5 rocker lever assemblies (exhaust, intake, injector)

8.2.7.6 valves (intake, exhaust)

8.2.7.7 valve stem guides

8.2.7.8 valve inserts

8.2.7.9 piston cooling nozzles

8.2.7.10 valve crossheads

8.2.7.11 connecting rod bearings

8.3 *Operational Measurements:*

8.3.1 *Units and Formats* – See Annex A8.

8.3.2 *Instrumentation Calibration*

8.3.2.1 *Fuel Consumption Rate Measurement Calibration* — Calibrate the fuel consumption rate measurement system before every reference oil test. Volumetric systems shall be temperature-

compensated and calibrated against a mass flow device. The flowmeter located on the test stand shall indicate within 0.2% of the calibration standard. The calibration standard shall be traceable to national standards.

8.3.2.2 *Temperature Measurement Calibration* — Calibrate the temperature measurement systems at least once every six months. Each temperature measurement system shall indicate within ± 0.5 °C of the laboratory calibration standard. The calibration standard shall be traceable to national standards.

8.3.2.3 *Pressure Measurement Calibration* — Calibrate the pressure measurement systems at least once every six months. Locate the pressure measurement transducers in a temperature-controlled environment to minimize calibration drift. The maximum temperature variation should not exceed ± 3 °C. The calibration standard shall be traceable to national standards.

8.3.3 *Temperatures:*

8.3.3.1 *Measurement Location* — The temperature measurement locations are specified in this section. The measurement equipment is not specified. Install the sensors such that the tip is located midstream of the flow unless otherwise indicated. The accuracy and resolution of the temperature measurement sensors and the complete measurement system shall follow the guidelines detailed in ASTM Research Report RR: D02-1218¹¹.

8.3.3.2 *Coolant Out Temperature* — Install the sensor upstream of the junction of the EGR coolant return.

8.3.3.3 *Coolant In Temperature* — Install the sensor on the right side of the coolant pump intake housing at the 1-in. NPT port as shown in Fig A4.7.

8.3.3.4 *Fuel In Temperature* — Install the sensor in the fuel pump inlet fitting as shown in Fig. A4.4.

8.3.3.5 *Oil Gallery Temperature* — Install the sensor at the 1/4-in. NPT hole on the left -rear of the engine as shown in Fig. A4.4.

8.3.3.6 *Intake Air Temperature* — Install the sensor as shown on Fig A4.5.

8.3.3.7 *Intake Manifold Temperature* — Install the sensor at the flange on the air inlet tube after the 90 degree elbow as shown in Fig. A4.7.

8.3.3.8 *Exhaust Temperature* — Install the sensor as shown in Fig. A4.6.

8.3.3.9 *Additional* — Monitor any additional temperatures that the laboratory considers beneficial. Measurement of the EGR Cooler gas inlet and outlet and coolant inlet and outlet is

highly recommended.

8.3.3.9.1 *Discussion* - Additional exhaust sensor locations are recommended, such as the exhaust ports and pre-turbine (front and rear). The detection of changes in exhaust temperature(s) is an important diagnostic.

8.3.4 *Pressures:*

8.3.4.1 *Measurement Location and Equipment* — The pressure measurement locations are specified in this section. The measurement equipment is not specified. The accuracy and resolution of the pressure measurement sensors and the complete measurement system shall follow the guidelines detailed in ASTM Research Report RR: D02-1218¹¹.

8.3.4.1.1 *Discussion* — A condensation trap should be installed at the lowest elevation of the tubing between the pressure measurement location and the final pressure sensor for Crankcase Pressure, Intake Air Pressure, and Exhaust Pressure. Route the tubing to avoid intermediate loops or low spots before and after the condensation trap.

8.3.4.2 *Oil Gallery Pressure* — Measure the pressure at the 9/16 in.-18 Compuccheck adapter at the left-front of the engine, as shown in Fig. A4.4.

8.3.4.3 *Oil Filter Inlet Pressure* — Measure the pressure at the 7/8 in.-14 o-ring plug located on the oil filter assembly. (Fig. A4.8).

8.3.4.4 *Oil Filter Outlet Pressure* — Measure the pressure at the 1/4-in. NPT port located on the oil filter assembly. (Fig. A4.8).

8.3.4.5 *Intake Manifold Pressure* — Measure the pressure at the 1/2-in. NPT port at the top-front of the intake manifold as shown in Fig. A4.7.

8.3.4.6 *Crankcase Pressure* — Measure the pressure at the boss on the front, left, top of the rocker cover as shown in Fig. A4.2

8.3.4.7 *Intake Air Pressure* — Measure the pressure on the intake air tube as shown in Fig. A4.5.

8.3.4.8 *Exhaust Pressure* — Measure the pressure on the exhaust tube as shown in Fig. A4.6.

8.3.4.9 *Fuel Pressure* — Measure the pressure at the 9/16-18 Compuccheck adapter on fuel pump body as shown in Fig. A4.4.

8.3.4.10 *Coolant Pressure* — Measure the pressure on top of the expansion tank as shown in Fig. X2.3.

8.3.4.11 *Additional* — Monitor any additional pressures considered to be beneficial. Measurement of the EGR cooler inlet and outlet coolant pressures and inlet and outlet gas

pressure is highly recommended.

8.3.5 Flow Rate:

8.3.5.1 *Flow Rate Location and Measurement Equipment* — The flow rate measurement locations are specified in this section. The equipment for the blowby rate and the fuel rate are not specified. The accuracy and resolution of the flow rate measurement system shall follow the guidelines detailed in ASTM Research Report RR: DO2-1218¹¹.

8.3.5.2 *Blowby* — The device used to measure the blowby flow rate is not specified. See section 6.2.11.

8.3.5.3 *Fuel Flow* — The fuel consumption rate is determined by measuring the fuel flowing to the day tank as shown in Fig. X2.2.

9. Engine/Stand Calibration and Non-Reference Oil Tests

9.1 *General* — Calibrate the test stand by conducting a test with a blind reference oil¹². Submit the results to the ASTM Test Monitoring Center (TMC) for determination of acceptance according to the Lubricant Test Monitoring System (LTMS)¹².

9.2 *New Test Stand* — A new test stand is defined as a test stand that has never been calibrated or has not completed an acceptable reference oil test within 18 months of the end-of-test (EOT) date of the last acceptable reference oil test. Under special circumstances, such as industry-wide parts or fuel shortages, the TMC may extend the time period beyond 18 months. Perform the following to introduce a new test stand.

9.2.1 *New Test Stand Calibration* — New stand calibration is determined according to the LTMS¹².

9.3 *Stand Calibration Period* — The calibration period is 6 months from the EOT date of the last acceptable reference oil test.

9.3.1 At its discretion, the TMC may schedule more frequent reference oil tests or extend the calibration period.

9.4 *Stand Modification and Calibration Status* - Modification of the test stand control systems or the conducting of any non-standard test, or both, can invalidate the calibration status. A non-standard test includes any test conducted under a modified procedure, non-procedural hardware, controller set-point modifications, or a combination thereof. The TMC should be contacted prior to any changes to determine the effect upon the calibration status.

9.5 Test Numbering System:

9.5.1 *General* — The test number has three parts,

X-Y-Z. X represents the test stand number, Y represents the engine serial number and Z represents the engine block run number. For example, test number 27-4B4607-2 indicates stand number 27, engine serial number 4B4607, and the second test on the engine block. Every test start (reference oil and non-reference oil) will increment Z by one, with the exception stated in 9.7.2.

9.5.2 *Reference Oil Tests* — A reference oil test conducted subsequent to an unacceptable reference oil test will include a letter suffix after Z. The letter suffix will begin with A and increment alphabetically until an acceptable reference oil test is completed. For example, if two consecutive unacceptable reference oil tests were conducted and the first test number was 27-4B4607-10, then the second test number would be 27-4B4607-10A. A third calibration attempt would have the test number 27-4B4607-10B. If the third test was acceptable, then 27-4B4607-10B would identify the reference oil test in the test report.

9.5.3 *Non-Reference Oil Tests* — No letter suffix will be added to Z for aborted or operationally invalid non-reference oil tests.

9.6 Reference Oil Test Acceptance:

9.6.1 Reference oil test acceptance and laboratory severity adjustment (SA) are determined in accordance with the LTMS¹².

9.7 Unacceptable Reference Oil Test:

9.7.1 It is recognized that some reference oil test results will not be within the LTMS acceptance limits. The laboratory, in conjunction with the TMC, shall attempt to determine the cause of the deviation. The TMC may solicit input from industry authorities to help determine the cause and extent of the problem.

9.7.2 If the laboratory is not within the LTMS acceptance limits and the TMC has determined that probable cause is isolated to an individual stand, then non-reference oil testing on other calibrated stands may continue.

9.7.3 If the laboratory is not within the LTMS acceptance limits and the TMC has determined that probable cause involves more than one stand, then the TMC may declare the particular stands non-calibrated. Non-reference oil tests in progress at the time of the calibration status change are not effected.

9.7.3.1 The laboratory shall attempt to identify and correct the cause and conduct an acceptable reference oil test in at least one of the stands to demonstrate resolution of the problem.

9.7.4 The TMC will assign reference oil when

satisfied that no particular problems exist or the problem has been resolved. The laboratory shall provide adequate documentation or findings, or both, to support the conclusions reached during this process. The conclusions shall be documented in the acceptable reference oil test report.

9.8 *Reference Oil Accountability:*

9.8.1 Laboratories shall provide a full accounting of the identification and quantities of all reference oils used. With the exception of the oil analyses required in section 11.6, perform no physical or chemical analyses of reference oils without written permission from the TMC. In such an event, include the written conformation and the data generated in the reference oil test report.

9.8.2 Retain used reference oil samples for 90 days from the EOT date.

9.9 *Non-Reference Oil Tests:*

9.9.1 This test method incorporates the use of a Severity Adjustment (SA) for non-reference oil test results. A control chart technique described in the LTMS is used to determine if a significant bias exists for crosshead mass loss, average sludge, or oil filter plugging, or combination thereof. When calibration results indicate a significant bias, an SA is determined according to the LTMS and applied to the non-reference oil test result. The SA and the adjusted result are reported on the report form. The SA will remain in effect until a new SA is determined from subsequent calibration tests.

9.9.1.1 *Discussion* - The report forms and data dictionary can be downloaded from the ASTM Test Monitoring Center (TMC) web page at <http://tmc.astm.cmri.cmu.edu/> or can be obtained in hardcopy format from the TMC.

9.9.2 *Last Start Date* -- A non-reference oil test shall commence engine warm-up (10.5) prior to the expiration of the calibration period (9.4).

10. Test Procedure

10.1 *Engine Installation and Stand Connections* - Install the test engine on the stand and connect the engine to the stand support equipment.

10.1.1 *Discussion* - A final check of valve and injector settings is recommended at this time.

10.2 *Coolant System Fill* - Install a new coolant filter, Cummins WF-2071. Fill the cooling system with pre-mixed Fleetguard Compleat PG. The coolant for non-reference oil tests may be reused provided the level of inhibitors is within specification as determined by DCA Level Test Kit, Cummins P/N CC2602 (X1.1). Use new coolant for each reference oil test.

10.2.1 *Discussion* - The coolant system should be pressurized to specification and checked for

leaks prior to adding the test oil.

10.3 *Oil Fill for Break-in:*

10.3.1 Install a new Cummins LF-3000 oil filter. The filter can be obtained from the supplier listed in X1.1.

10.3.2 Use the pressurized oil fill system, per section 6.2.8, to charge the engine with 24.7 kg of test oil at the location shown in Fig. A4.2.

10.3.3 *Engine Build Committed* - Once the test oil has been introduced into the engine, the engine build and the test number are valid only for the respective test. However, if the engine has not been cranked (whereby, the test parts have not been subjected to wear or injected fuel, or both), then the new parts may be used again. Disassemble and clean the engine according to Section 8.

10.4 *Fuel Samples* - Take a 1.0 L fuel sample at the start of the test and at EOT.

10.5 *Engine Warm-up* -- The engine warm-up conditions are shown in Table 2.

10.5.1 *Shutdown during Warm-up* -- The warm-up timer shall stop at the initiation of shutdown. When ready to resume warm-up, start the engine, and continue warm-up from the stage in which the shutdown occurred. The warm-up timer resumes when the engine speed and the engine torque are within specification.

10.6 *Engine Break-in* - Perform a break-in on each new engine build prior to the start of the 300-h test procedure. The break-in conditions are shown in Table 3.

10.6.1 Start the engine, perform the warm-up (Table 2) and proceed directly to the break-in (Table 3).

10.6.1.1 *Shutdown during Break-in* - The break-in timer shall stop at the initiation of shutdown. When ready to resume break-in, start the engine, perform the warm-up, and proceed to the break-in conditions. The break-in timer resumes when the engine speed and the engine torque are within specification. If a shutdown occurs within the last 10 min of break-in, the break-in can be considered complete. Such an occurrence shall be noted in Other Comments of the Unscheduled Maintenance and Downtime Summary report form.

10.6.2 At the completion of break-in, perform a normal shutdown (Table 4) and shut off the engine.

10.6.3 Drain the oil from the engine and the external oil system.

10.6.4 Remove the LF-3000 oil filter.

10.6.5 Properly dispose of the drain oil and oil

filter.

10.6.6 Once completed, the break-in is not repeated for the respective test.

10.6.6.1 *Discussion* - Use the break-in as an opportunity to confirm engine performance and to make repairs prior to the start of the test procedure.

10.7 *Shutdown and Maintenance* – The test may be shut down at the discretion of the laboratory to perform repairs. However, the intent of this test method is to conduct the test without shutdowns.

10.7.1 *Normal Shutdown* – Proceed directly from the operating conditions to the shutdown schedule in Table 4.

10.7.2 *Emergency Shutdown* – An emergency shutdown occurs when the normal shutdown was not performed, such as an alarm condition. Include “Emergency Shutdown” on the downtime report of the Unscheduled Downtime and Maintenance Summary report form.

10.7.3 *Maintenance* — Engine components or stand support equipment, or both, may be repaired or replaced at the discretion of the laboratory and in accordance with this test method.

10.7.3.1 Removal of the crossheads prior to test completion will invalidate the test.

10.7.3.2 Removal and replacement of the oil filter due to engine gallery pressure below 200 kPa shall be determined solely at the discretion of the laboratory and per these guidelines:

a) if the test is on a non-reference oil test and the test has not completed stage E per Table 5 the test is considered non-interpretable per section 11.13.

b) if the test is on a non-reference oil test and the test has completed stage E per Table 5 the test can be continued with a new filter with the appropriate shutdown correction per section 11.6.2. A filter change shall be noted on the report form.

10.7.4 *Downtime* - The limit for total downtime and number of shutdowns is not specified. Record all shutdowns, pertinent actions, and total downtime during the 300-h test procedure on the report form.

10.8 *300-h Test Procedure:*

10.8.1 Measure and record the mass of a new test oil filter, Cummins P/N 390383200 (Table A3.1), and install on the engine.

10.8.2 *Oil Fill for Test* - Using the pressurized oil fill system (6.2.7), charge the engine with 24.7 kg of test oil at the location shown in Fig. A4.2.

10.8.3 Start the engine and perform the warm-up (Table 2).

10.8.3.1 *Zero-h Oil Sample* – Take a 0.23 kg oil sample of the fresh oil out of the original oil

container.

10.8.4 *Operating Conditions* – After warm-up, proceed directly to the 300-h Test Sequence (Table 5).

20.8.4.1 *Stage Transition Times* – 1 min (RPM only), 15 min (Intake Manifold Temperature)

10.8.5 *Injection Timing Change* – The fuel injection timing may be adjusted during Stage A, C and E only to achieve the soot target window, provided the first 25 hours of the test are run at a timing of 16.1 TVC and the 50-h soot is at least 2.8%. It is recommended that the timing remain at 16.1 TVC for the first 50 hours of the test and only changed if the 25 hour soot reading is greater than 2.0%.

10.8.6 *% Soot Validity:*

10.8.6.1 *Reference Oil Test* -- % soot shall be 8.5 +0.5%/-1.0% @250 h and the average soot shall be $\geq 4.6\%$.

10.8.6.2 *Non-Reference Oil Test* -- % soot shall be $\geq 8.0\%$ @250 h and the average soot shall be $\geq 4.6\%$.

10.8.7 *Test Timer* – The test sequence timer starts when all controlled parameters shown in Stage A of Table 5 are within specification. If a shutdown(s) occurs, the test timer stops immediately at the initiation of the shutdown. The test timer resumes when the test has been returned to the appropriate stage and all controlled parameters are within specification.

10.8.7.1 The test timer continues incrementing through stage transitions.

10.8.8 *Operational Data Acquisition* — Record all operational parameters shown in Table 5, except Blowby Flow, with automated data acquisition at a minimum frequency of once every 6 min. Record Blowby Flow a minimum of once every 8 h. Recorded values shall have minimum resolution in accordance with Annex A8. Report the characteristics of the data acquisition system on the report form.

10.8.8.1 *Discussion* - The report forms and data dictionary can be downloaded from the ASTM Test Monitoring Center (TMC) web page at <http://tmc.astm.cmri.cmu.edu/> or can be obtained in hardcopy format from the TMC.

10.8.8.2 The operational data is reported on the report form .

10.8.9 *Oil Purge, Sample and Addition* — Perform a forced oil drain, oil sample and oil addition at the end of each 25-h period. Add new oil and purge sample returns to the external oil system reservoir.

Table 2 Warm-up Conditions

Parameter	unit	Stage				
		A	B	C	D	E
Stage Length	min	5	5	5	5	5
Speed	r/min	700	1200	1600	1600	1600
Torque	N•m	135	270	540	1085	1470
Coolant Out Temperature ^A	°C	105	105	105	105	105
Oil Gallery Temperature ^A	°C	130	130	130	130	130
Intake Manifold Temperature ^A	°C	70	70	70	70	70

^A Maximum

Table 3 Break-in Conditions

Parameter	Unit	Specification
Stage Length	min	120
Speed	r/min	1600 ± 5 (target)
Torque ^A	N•m	1930
Fuel Flow	kg/h	64.4 ± 0.9 (target)
Coolant Out Temperature	°C	65.5
Fuel In Temperature	°C	40 ± 2
Oil Gallery Temperature	°C	115.5
Turbo Inlet Air Temperature	°C	record
Intake Manifold Temperature	°C	65.5 (target)
Oil Gallery Pressure	kPa	record
Oil Filter Delta Pressure	kPa	record
Intake Manifold Pressure	kPa abs.	≤ 320
Exhaust Pressure	kPa abs.	107 ± 1
Crankcase Pressure	kPa	record
Inlet Air Pressure	kPa abs.	record
EGR Rate	%	9.4 ± 0.4 (target)
Coolant System Pressure	kPa	103 ± 4

^A At standard atmospheric temperature and pressure

Table 4 Normal Shutdown Conditions

Parameter	unit	Stage		
		B	A	Idle
Stage Length	min	5	5	5
Speed	r/min	1200	700	700
Torque	N•m	270	135	<40
Coolant Out Temperature	°C	105 max	105 max	105 max
Intake Manifold Temperature	°C	70 max	70 max	70 max
Oil Gallery Temperature	°C	130 max	130 max	30 max

10.8.9.1 Do not shut down the engine for oil sampling and oil addition. Purge oil samples are retained at the discretion of the laboratory.

10.8.9.2 *Full and Drain Weight* - Record the oil weight indicated by the external oil system at the completion of the first test hour, this value establishes the *full weight*. Subtract 1.4 kg (3.1 lbf) from the full weight, this value establishes the *drain weight*. The full weight and the drain weight are fixed for the test.

10.8.9.3 At the end of each 25-h period, take a 0.23 kg (0.51 lbf) oil purge sample and then a 0.23

kg (0.51 lbf) oil analysis sample. Identify the oil sample container with the test number, oil code, date and test hour.

10.8.9.4 If the remaining oil weight is greater than the drain weight, then remove an additional purge sample of sufficient quantity to equal the drain weight.

10.8.9.5 If the remaining oil weight is less than the drain weight, then add a maximum of 0.23 kg (0.51 lbf) of the current purge oil sample to attain the drain weight. Do not add any new oil or a previous purge oil sample to attain the drain

weight.

10.8.9.6 Add 1.4 kg (3.1 lbf) of new oil, except at 300 h.

10.9 *End of Test (EOT):*

10.9.1 After completing the test procedure, perform a normal shutdown (Table 4), and shut off the engine. Release the coolant system pressure and drain the coolant. Disconnect the stand support equipment.

10.9.1.1 *Discussion* - The coolant and oil could be hot. The installation of a valve to safely vent the coolant system pressure is recommended.

10.9.2 Drain the oil from the engine and the external oil system. Commence the oil drain within 2 h after shutdown and allow a minimum duration of 30 min.

10.9.3 Retain a minimum of two 3.5 L samples of test oil. Identify the oil sample container with the test number, oil code, EOT date and test hour. Properly dispose of any residual oil drain.

10.9.4 Engine Disassembly – Disassemble the engine and remove the following components for ratings or measurements, or both:

10.9.4.1 *Rocker Cover and Oil Pan* - The rocker cover and oil pan may either remain on the engine or be removed from the engine. However, maintain the rocker cover and oil pan in a horizontal position for a minimum of 6 h after the EOT oil drain.

10.9.4.2 *Rocker Cover and Oil Pan Sludge Rating* – After 6 h in a horizontal plane, place the oil pan and rocker cover at a 60° angle from horizontal (lengthwise) with the front end and the inside surface down for a minimum of 8 h in a temperature-controlled environment.

10.9.4.3 Crossheads

10.9.4.4 Adjusting Screws

10.9.4.5 Pistons

10.9.4.6 Piston Rings

10.9.4.7 Rod Bearings

11. Calculations, Ratings and Test Validity

11.1 Crosshead Mass Loss -- Use the procedure shown in 8.1.6 to determine individual EOT crosshead mass. Report the crosshead measurements and calculations on the report form.

11.1.1 Separate the crossheads into intake and exhaust groups.

11.1.2 Calculate the mass loss for each crosshead (pre-test - post test).

11.1.3 Calculate the average mass loss, \bar{x} , and the standard deviation of the mass loss, s , for each group and report as As Measured in the

Intake/Exhaust Summary section

11.1.4 Subtract \bar{x} (11.1.3) from each individual crosshead mass loss in the respective group. Take the absolute value of the difference and divide by the s (11.1.3) of the respective group.

11.1.5 A result in 11.1.4 greater than 1.887 mg is an outlier. Remove the maximum outlier from the

group and recalculate \bar{x} and s for each group and report as Outlier Screened in the Intake/Exhaust Summary section. Remove only one outlier per group.

11.1.7 Calculate the average and the standard deviation of all mass loss values combined (intake and exhaust) and report as As Measured in the Overall Summary.

11.1.8 Calculate the average and the standard deviation of all mass loss values combined (intake and exhaust) with outliers removed and report as Outlier Screened in the Overall Summary.

11.1.9 Calculate the following and report as Adjusted to 4.6% Average Soot in the Overall Summary:

$$10^{[(\log(X) - 0.2575*(AS - 4.6\%)]} \quad (\text{Eq. 1})$$

where:

X = Outlier Screened Crosshead Average Mass Loss value in the Overall Summary

AS = 13 point average of the 25 h reported soot values (calculated)

11.2 Adjusting Screw Mass Loss - Use the procedure shown in 8.1.10 to determine individual EOT adjusting screw mass. Report the adjusting screw measurements and calculations on the report form.

11.2.1 Separate the adjusting screws into injector, intake and exhaust groups.

11.2.2 Calculate the mass loss for each adjusting screw (pre-test - post test).

11.3 *Rod Bearing Mass Loss* -- Use the procedure shown in 8.1.7 to determine individual EOT rod bearing mass. Report the rod bearing measurements and calculations on the report form.

11.3.1 Calculate the mass loss for each rod bearing section (pre-test - post test).

11.3.2 Calculate the average mass loss and the standard deviation of the mass loss.

11.4 *Sludge Ratings:*

11.4.1 Rate the rocker arm cover sludge and the oil pan sludge according to CRC Manual No. 12¹⁰ at the locations specified on the report form, respectively, and report in the test report..

Table 5 300-h Test Sequence

Stage Parameter	unit	A	B	C	D	E	F
Stage Length	h	50	50	50	50	50	50
Speed	r/min	1800 ± 5	1600 ± 5	1800 ± 5	1600 ± 5	1800 ± 5	1600 ± 5
Power	kW	record	record	record	record	record	record
Torque (typical) ^A	N•m	1300	1930	1300	1930	1300	1930
Fuel Flow	kg/h	58 ± 1	64.4 ± 1	58 ± 1	64.4 ± 1	58 ± 1	64.4 ± 1
Intake Manifold Temp.	°C	80	65.5	80	65.5	80	65.5
Blowby Flow	L/min	record	record	record	record	record	record
Coolant Out Temp.	°C	65.5 ± 2	65.5 ± 2	65.5 ± 2	65.5 ± 2	65.5 ± 2	65.5 ± 2
Coolant In Temp.	°C	record	record	record	record	record	record
Coolant Delta Temp.	°C	record	record	record	record	record	record
Fuel In Temp.	°C	40 ± 2	40 ± 2	40 ± 2	40 ± 2	40 ± 2	40 ± 2
Oil Gallery Temp.	°C	115 ± 2	115 ± 2	115 ± 2	115 ± 2	115 ± 2	115 ± 2
Turbo Inlet Temp.	°C	record	record	record	record	record	record
Intake Manifold Press.	KPa abs.	≥ 300	≥ 320	≥ 300	≥ 320	≥ 300	≥ 320
Exhaust Temp.	°C	record	record	record	record	record	record
Fuel Pressure	kPa	record	record	record	record	record	record
Oil Gallery Pressure	kPa	record	record	record	record	record	record
Oil Filter Delta Press.	kPa	record	record	record	record	record	record
Coolant System Press. ^B	kPa	99-107	99-107	99-107	99-107	99-107	99-107
Exhaust Press.	kPa abs.	107 ± 1	107 ± 1	107 ± 1	107 ± 1	107 ± 1	107 ± 1
Crankcase Press.	kPa	record	record	record	record	record	record
Inlet Air Press.	kPa abs.	record	record	record	record	record	record
Intake CO ₂	%	0.97-1.09	0.78-0.85	0.97-1.09	0.78-0.85	0.97-1.09	0.78-0.85
EGR Rate (daily check)	%	record	8.5 – 9.8	record	8.5 – 9.8	record	8.5 - 9.8

^A At standard atmospheric temperature and pressure

^B Measure the coolant pressure on the top of the expansion tank

11.4.2 Average the rocker arm cover sludge and oil pan sludge ratings. Report as *Average Sludge Rating* on the test report.

11.5 *Piston Ratings* — Rate the pistons according to CRC Manual No. 18 (Revised May, 1994)¹⁰ at the locations and with the special instructions noted in Annex A9. Report the ratings on the test report. For the varnish ratings, use the CRC expanded varnish scale and convert to demerits.

11.6 *Oil Filter Plugging* -- Oil filter plugging (ΔP_{FP}) is indicated by the increase of the oil filter differential pressure (ΔP) during the test. The general equation for oil filter plugging is as follows:

$$\Delta P_{FP} = \Delta P_{ADJ(MAX)} - \Delta P_{INIT} \quad (\text{Eq. 2})$$

$$\Delta P = \text{Oil Filter Outlet Pressure} - \text{Oil Filter Inlet Pressure} \quad (\text{Eq. 3})$$

$$\Delta P_{ADJ(MAX)} = \text{maximum adjusted } \Delta P \text{ during the test} \quad (\text{Eq. 4})$$

ΔP_{INIT} = first ΔP reading of the test with target and range parameters within specification

11.6.2.1 *No Shutdowns* – No correction is performed, Eq. 2 becomes:

$$\Delta P_{FP} = \Delta P_{MAX} - \Delta P_{INIT} \quad (\text{Eq. 5})$$

where,

ΔP_{MAX} = maximum ΔP during the test

11.6.3 *Shutdowns* - Separate the test into segments demarcated by shutdowns (see Fig. A11.1). Segment 1 is from the SOT to shutdown 1, segment 2 is from shutdown 1 to shutdown 2, and so on.

11.6.3.1 *ΔP Correction* -- Determine the correction due to each shutdown:

(a) If $\Delta P_{BS(N)} - \Delta P_{AS(N)} < 4$ kPa, then $\Delta P_{CORR(N)} = 0$

(b) If $\Delta P_{BS(N)} - \Delta P_{AS(N)} > 4$ kPa, then $\Delta P_{CORR(N)} = \Delta P_{BS(N)} - \Delta P_{AS(N)}$

where,

N = shutdown number

$\Delta P_{BS(N)}$ = last ΔP reading before initiation of shutdown N

$\Delta P_{AS(N)}$ = first ΔP reading after shutdown N with target and range parameters within specification

$\Delta P_{CORR(N)}$ = ΔP correction due to shutdown N

11.6.4 *Adjusted ΔP* -- Add ΔP_{CORR} to each ΔP reading subsequent to the shutdown. In general, sum the ΔP_{CORR} of prior shutdowns and add to each ΔP reading of the current segment (see Fig. A11.2).

$$\Delta P_{ADJ(N)} = \Delta P_N + [\sum \Delta P_{CORR(N-1)}]_{2, \dots, N} \quad (\text{Eq. 6})$$

where,

N = segment number

$\Delta P_{\text{ADJ}(N)}$ = adjusted ΔP readings during segment N

ΔP_N = individual ΔP readings during segment N

$\Delta P_{\text{CORR}(N)}$ = ΔP correction at shutdown N

$\Delta P_{\text{ADJ}(1)}$ = ΔP_1

11.6.5 Report oil filter plugging (ΔP_{FP}) as *Filter Plugging Delta P* for a non-reference oil test or a reference oil test in the appropriate section of the test report form. Note that 250 h filter plugging and 300 h filter plugging are reported. Separate calculations shall be performed to determine each value as reported.

11.6.6 Plot ΔP vs. test hour on the report form.

11.7 *Oil Analyses* -- Analyze the oil samples for viscosity at 100°C, wear metals (iron, copper, lead, chromium, and aluminum), TAN, TBN, and %soot (TGA) according to the schedule and methods shown in A12 and report on the test report.

11.8 *Oil Consumption* — Sum the weight of the oil consumed for the test and report in the appropriate section of the test report for non-reference oil test or reference oil test. The test is non-interpretable if the oil consumption exceeds 15 kg.

11.9 *Fuel Analyses* — Report the analyses provided by the fuel supplier on the test report. Report the analyses of the final batch if more than one fuel batch was used.

11.9.1 *Additional Analyses* -- Perform the following analyses on the 1 L new and EOT fuel samples, and record on the test report..

11.9.1.1 API Gravity at 15.6 °C (60 °F), Test Method D287 or equivalent

11.9.1.2 Total Sulfur, % wt., Test Method D129 or equivalent

11.10 *Ring Mass Loss and Gap* - Record the piston ring measurements and calculations on the test report.

11.10.1 Calculate the mass loss and gap for the top, second, and oil ring (pre-test - post test).

11.10.2 Calculate the average mass loss, \bar{x} , and the standard deviation of the mass loss, s , for the top, second and oil rings

11.10.3 Subtract \bar{x} (11.10.2) from each individual top ring mass loss. Take the absolute value of the difference and divide by the s (11.10.2).

11.10.4 A result in 11.10.3 greater than 1.887 mg is an outlier. Remove the maximum outlier from

the group and recalculate \bar{x} and s for each group and report as Outlier Screened in the test report. Remove only one outlier.

11.10.5 Calculate the average and the standard

deviation of all mass loss values and report as As Measured in the Overall Summary.

11.10.5 Calculate the average and the standard deviation of all mass loss values with the outlier removed and report as Outlier Screened in the Overall Summary

11.11 *EGR % Mass* – The EGR percent mass calculation is determined by measuring carbon dioxide (CO₂) in the exhaust and intake air streams. A computerized spreadsheet is available from Cummins Inc. in order to correctly calculate the EGR % Mass. The locations of the CO₂ probe for the exhaust and intake are noted in Figures A4.6, A4.13 and A4.14. The exhaust probe should be inserted fully until the probe tip touches the opposing wall then retracted 10 mm.

11.11.1 *Discussion* - If the required EGR rate *cannot* be obtained when a restriction plate on the EGR cooler is *not used*, then the intake manifold pressure should be decreased to no lower than the specified limit using the location specified in Section 6.2.2.

11.12 *Assessment of Operational Validity* – Determine operational validity according to Annex A12. Test validity is reported in the test report.

11.13 *Assessment of Test Interpretability* — A test is non-interpretable when the total oil consumption exceeds 21 kg. A non-reference test is non-interpretable when the 250 h soot is less than 8.0% (10.8.6). A non-reference test is non-interpretable when the oil gallery pressure drops below 200 kPa before 250 h (10.7.3.2) Interpretability is reported in the test report.

12. Test Report

12.1 *Report Forms* – The report forms and data dictionary are available through the TMC. See section 10.8.8.

12.2 *Reference Oil Test* — Send the test report and any other supporting information, to the TMC¹⁴ by facsimile or electronic transmission within five days of the EOT date for test acceptance determination. Reference oil test reports should be mailed or electronically transmitted to the TMC within 30 days of the EOT date.

12.2.1 *Electronic Transmission of Test Results* — Use ASTM Data Communications Committee Test Report Transmission Model (Section 2-Flat File Transmission Format)¹²

13. Precision and Bias

13.1 *Precision:*

13.1.1 Test precision is established on the basis of operationally valid reference test results

monitored by the TMC. Research Report RR:D02-XXXX contains the industry data developed prior to establishment of this test method.

13.1.1.1 Intermediate precision (r) (formerly called repeatability) is the difference between two test results obtained by a laboratory using the same test method and the same oil. For this test method, intermediate precision values are reported in Table 6.

13.1.1.2 Reproducibility (R) is the difference between two test results obtained by different laboratories, within a short time period, using the same test method and the same oil. For this test method, reproducibility values are reported in Table 6.

13.1.2 Test precision, as of

13.1.3 The TMC will be able to update precision data as it becomes available.

13.2 Bias – Bias is determined by applying an accepted statistical technique to reference oil test results. When a significant bias is determined, a severity adjustment is permitted for non-reference oil test results.

14. Keywords

14.1 lubricants, diesel engine oil, Cummins M11 EGR, crosshead wear, top ring weight loss, sludge, oil filter delta pressure, exhaust gas recirculation, valve train

TABLE 6 Test Precision

Test Result	Intermediate Precision, (r)	Reproducibility, (R)
Measured Units		
Adjusted top ring weight loss, mg		
Average sludge ratings, merits		
Transformed Units		
Adjusted crosshead wear, mg		
Oil filter ΔP , kPa		

ANNEXES

(Mandatory Information)

- A1. Safety Precautions
- A2. Mandatory Supplier List
- A3. Engine Build Parts Kit
- A4. Sensor Locations and Special Hardware
- A5. External Oil System
- A6. Fuel Specification
- A7. Cummins Service Publications
- A8. Specified Units and Formats
- A9. Piston Rating Locations
- A10. Oil Analyses
- A11. Oil Filter Plugging
- A12. Determination of Operational Validity

A1. SAFETY PRECAUTIONS

A1.1 The operating of engine tests can expose personnel and facilities to safety hazards. Personnel trained and experienced with engine testing should perform the design, installation, and operation of test stands.

A1.2 Guards (shields) should be installed around all external moving, hot, or cold components. Design the guard to contain the energy level of a rotating component should the component break free. Fuel, oil, coolant and electrical wiring should be properly routed, guarded, grounded and kept in good order.

A1.3 The test stand should be kept free of oil and fuel spills and tripping hazards. Containers of oil or fuel, or both, should not be permitted to accumulate in the testing area. Fire fighting equipment should be immediately accessible. Normal precautions should be observed whenever using flammable solvents for cleaning purposes.

A1.4 Safety masks, glasses, or hearing protection, or a combination thereof, should be worn by personnel working on the test stand. No loose or flowing clothing, including long hair or other accessory to dress, should be worn near rotating equipment. Personnel should be cautioned against working alongside the engine and driveline while the engine is running.

A1.5 Interlocks should automatically shutdown the engine when an anomaly in any of the following occur: engine or dynamometer coolant temperature, engine oil pressure, dynamometer field current, engine speed, exhaust temperature, excessive vibration or when the fire protection system is activated. The interlock should include a method to cut off the fuel supply to the engine at the injector pump (including the return line). A remote fuel cut off station (external to the test stand) is recommended.

A1.6 Employ other safety precautions as required by regulations.

A2. MANDATORY SUPPLIER LIST

A2.1 Obtain the test fuel shall from the supplier listed below:

Phillips Petroleum

Type: RD-9 (PC-9 fuel)

A2.2 Obtain the test engine, the engine build parts kit, and the ECM from the CPD listed below. Direct questions or correspondence concerning Cummins test parts to the CPD listed below.

Test Engineering, Inc.

12718 Cimarron Path

San Antonio, TX 78249-3417

Phone: (210) 690-1958

Fax: (210) 690-1959

A3. ENGINE BUILD PARTS KIT

Table A3.1 Engine Build Parts Kit

Description	Cummins P/N		Per Kit	Critical
Cam Follower Parts				
Injector cam follower assv	3417645		6	Y
Valve cam follower	3161475		12	Y
Cam follower shaft	3417766		2	Y
Cam follower shaft support (end)	3064583		1	Y
Cam follower shaft support	3895831		1	Y
Cam follower shaft support (center)	3895830		5	Y
Cam follower shaft support (end)	3064582		1	Y
Plain washer	3009330		7	
Cylinder Head Parts				
Expansion plug	3895479		2	Y
Expansion plug	206741		2	
Expansion plug	3007635		8	
Valve seat (exhaust)	3088980		12	
Valve insert (intake)	3088978		12	
Valve stem guide	3073512		24	
Valve spring	3895860		24	Y
Intake valve	3417778		12	
Valve collet	3275354		48	
Exhaust valve	3417779		12	
Valve spring retainer	3883512		24	Y
Spring guide	3070072		24	
Pine plug	3008465		16	
Orifice plug	3820749		6	
Valve stem seal, intake	4003966		12	Y
Valve stem seal, exhaust	4003966		12	Y
Overhead Components				
		Casting		
Rocker lever assembly (exhaust)	3400974	4003906	3	Y
Rocker lever assembly (exhaust)	3400971	4003903	3	Y
Rocker lever assembly (intake)	3400973	4003905	3	Y
Rocker lever assembly (intake)	3400972	4003906	3	Y
Rocker lever assembly (injector)	3069020	3068947	6	Y
Rocker lever shaft	3417765		2	Y
Valve crosshead (EGR batch)	3070175		12	Y
Push rod	3068390		12	
Push rod	3076046		6	
Rocker lever support	3893584		4	
Rocker lever support	3079662		2	
Rocker lever support	3079661		2	
Retaining clamp	3077444		8	
Pistons/Rings/Liner				
Piston top	3896030		6	Y
Piston skirt	4070653		6	Y
Piston pin	3063843		6	
Retaining ring	3016652		12	
Top compression ring	K171646		6	Y
Second compression ring	3899413		6	Y
Oil ring	3161808		6	
Cylinder liner	3080760		6	Y
Miscellaneous Components				
Pressure regulator plunger	3068979		1	
Compression spring	3010146		1	
Retainer plug	3895718		1	
Piston cooling nozzle	3080708		6	
Rectangular seal	3047188		6	
Oil cooler	3161781		1	
Connecting rod bearing	3016760		12	Y
Gasket, Stainless Steel EGR	3680850		2	Y
Gasket, Exhaust to EGR Cooler	T4006084		1	Y
EGR Hose			2	Y
Engine Block	4060393		1	Y
Cylinder Head	4004086		1	
Turbo	3594263			
Oil filter			1	Y

A4. SENSOR LOCATIONS AND SPECIAL HARDWARE

A4.1 Figure Description:

A4.1.1 Oil Heat Exchanger Adapter Blocks, Oil Cooler Block-off Plate (Fig. A4.1)

A4.2 Oil Heat Exchanger, Oil Fill Location, Crankcase Pressure (Fig. A4.2)

A4.3 Oil Pan Modification (Fig. A4.3)

A4.4 Fuel In Temperature, Fuel Pressure, Oil Gallery Temperature, Oil Gallery Pressure (Fig. A4.4)

A4.5 Intake Air Tube (Fig. A4.5)

A4.6 Exhaust Tube (Fig. A4.6)

A4.7 Intake Manifold Pressure, Intake Manifold Temperature, Coolant Out Temperature, Coolant In Temperature (Fig. A4.7)

A4.8 Oil Filter Outlet Pressure, Oil Filter Inlet Pressure, Filter Head return to Sump Location, Thermostat Location, Engine Oil Pressure Charge Location (Fig. A4.8)

A4.9 Aftercooler Assembly (Fig. A4.9)

A4.10 EGR Hardware Locations (Fig. A4.10)

A4.11 EGR Hardware Locations (Fig. A4.11)

A4.12 EGR Cooler Temperature and Pressure Locations for Exhaust Gas (Fig. A4.12)

A4.13 Intake Manifold CO₂ Probe Insertion (Fig. A4.13)

A4.14 Intake Manifold CO₂ Probe Location (Fig. A4.14)

A4.15 Engine Position Sensor

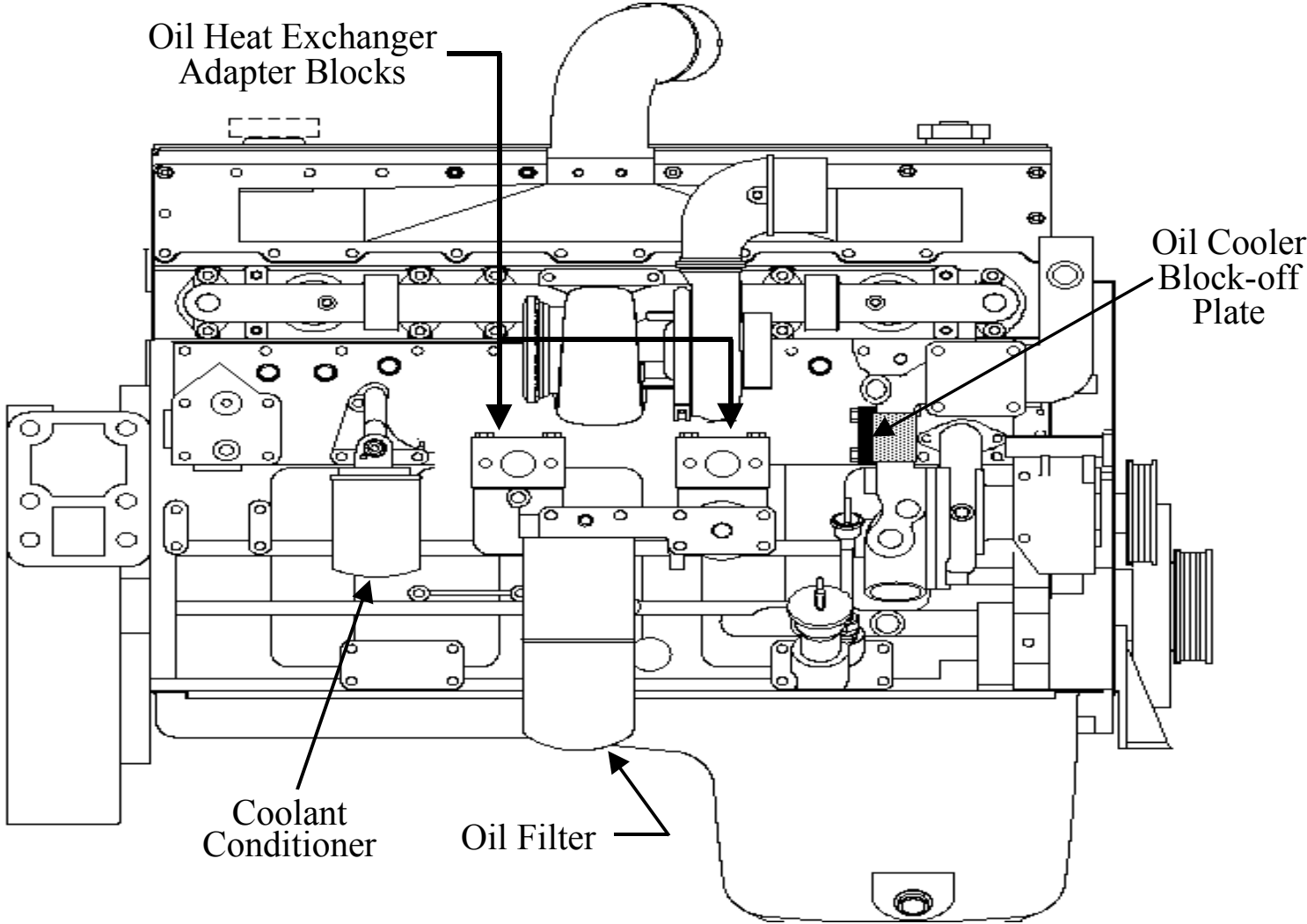

FIG. A4.1

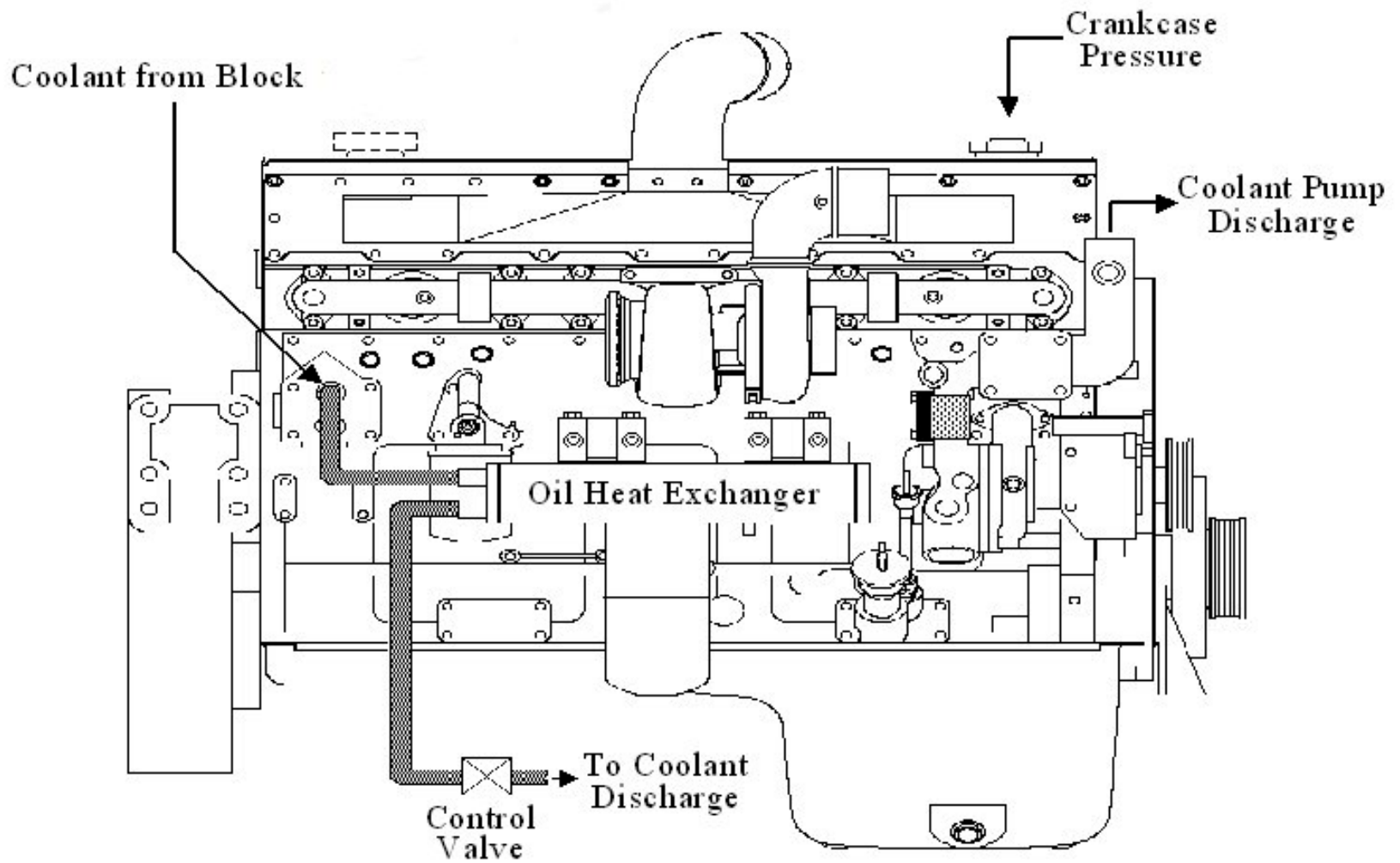

FIG. A4.2

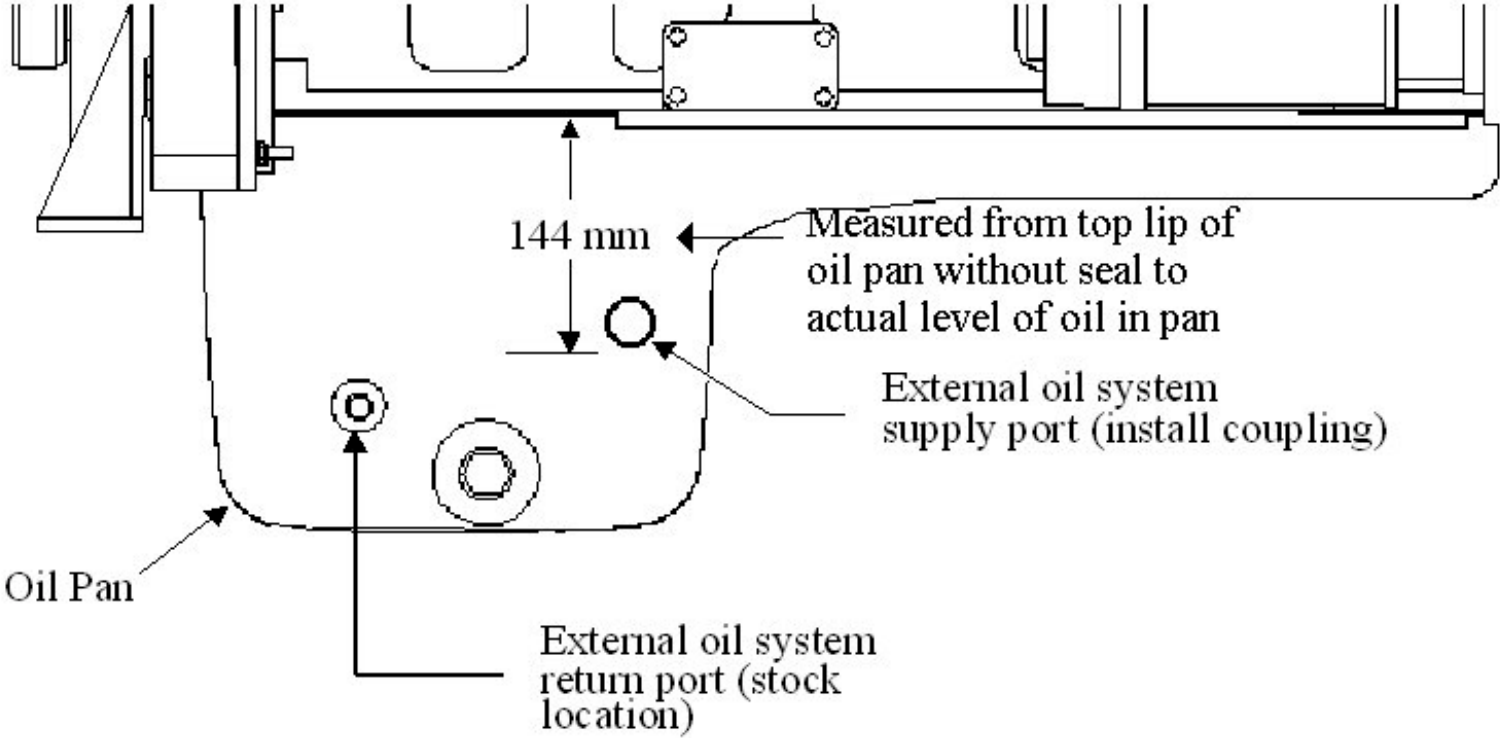

FIG. A4.3

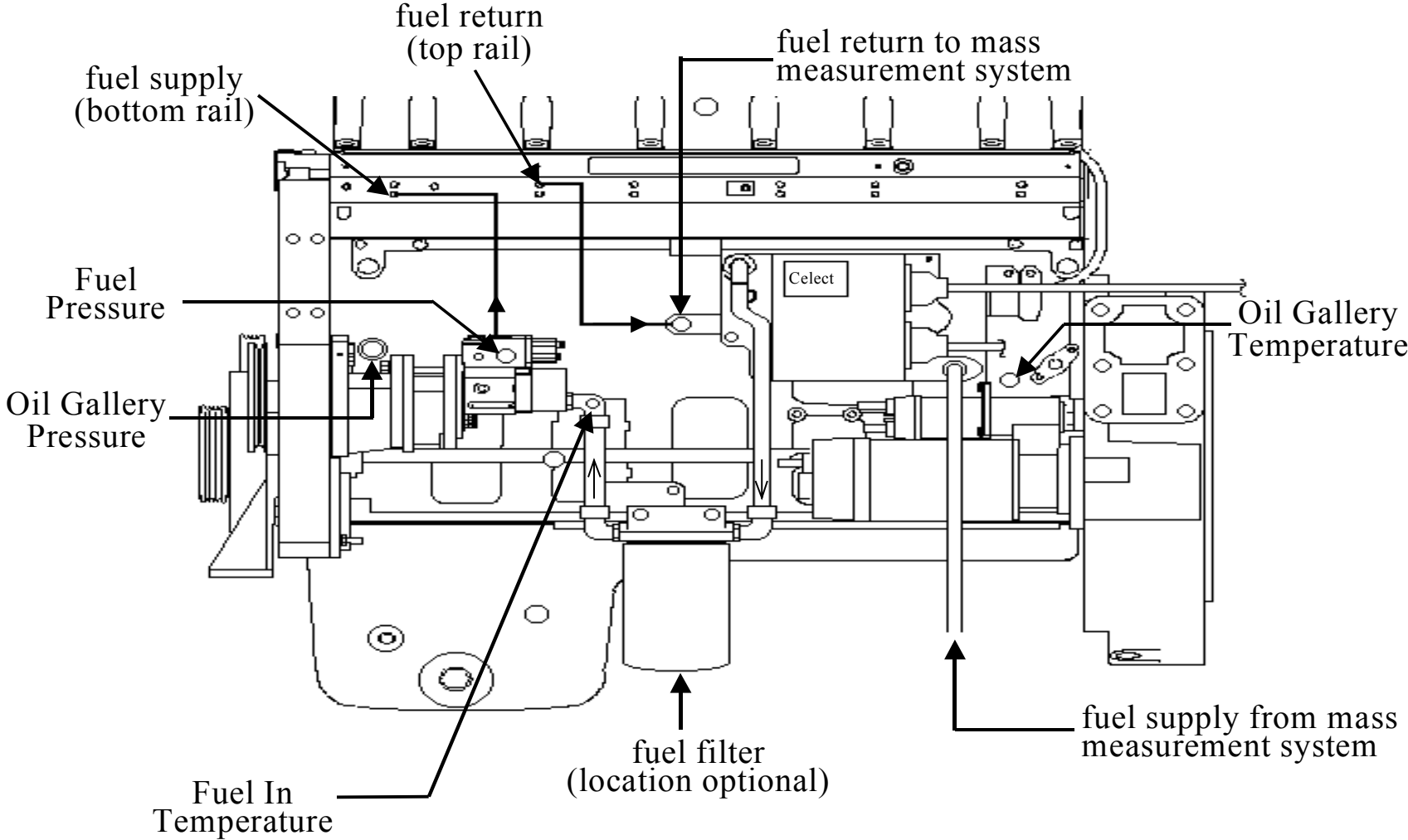
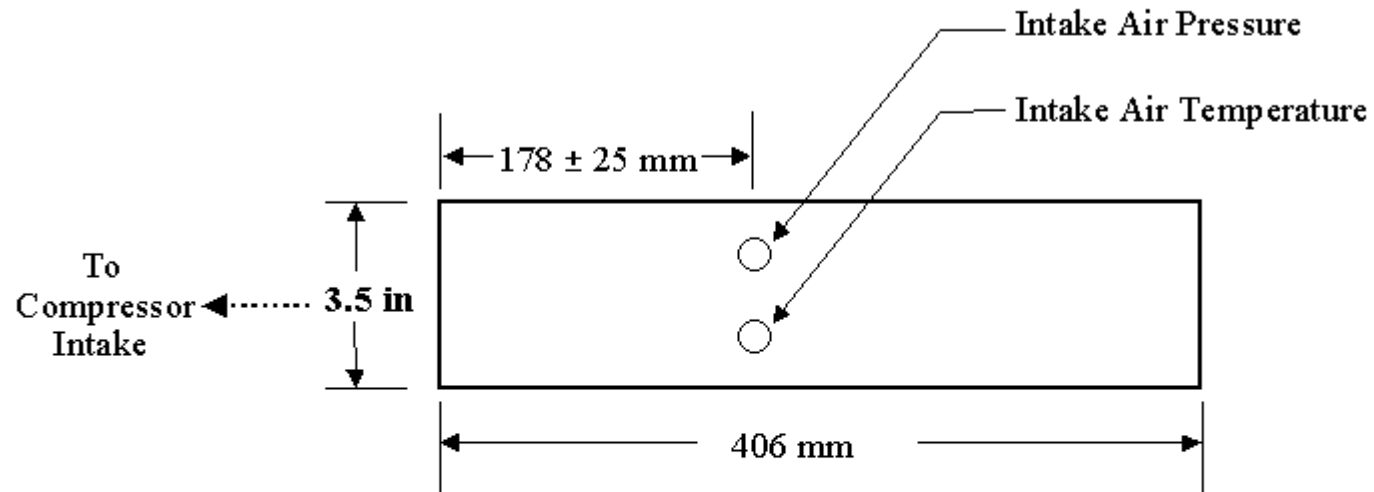

FIG. A4.4



The relative radial position and spacing of Intake Air Restriction and Intake Air Temperature is not specified.

Tubing: 3.5 in. O.D. by 0.0625 in. wall thickness

FIG. A4.5

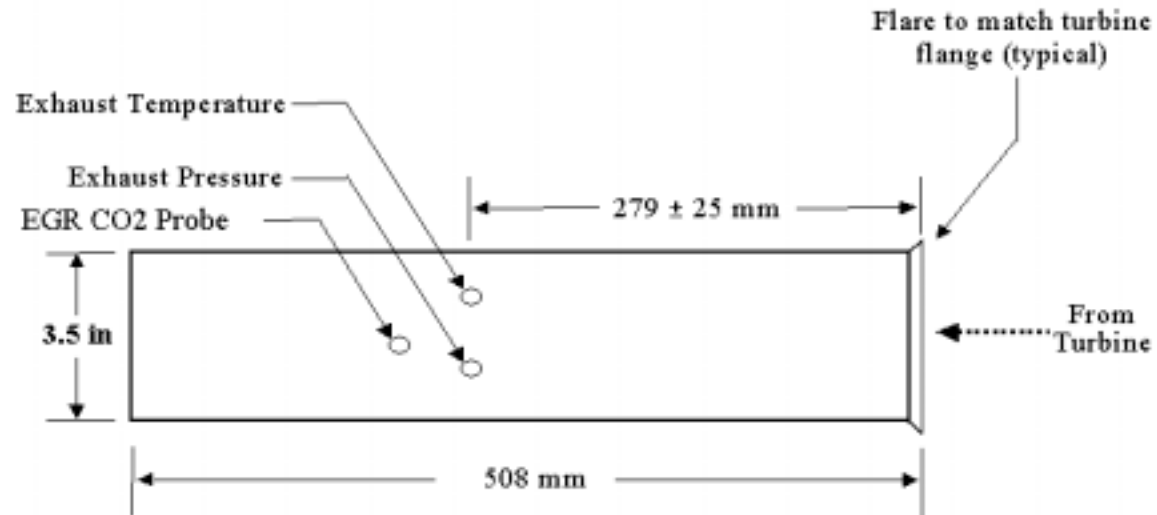

The relative radial position and spacing of Exhaust Pressure and Exhaust Temperature is not specified.

Tubing: 3.5 in. O.D. by 0.0625 in. wall thickness

FIG. A4.6

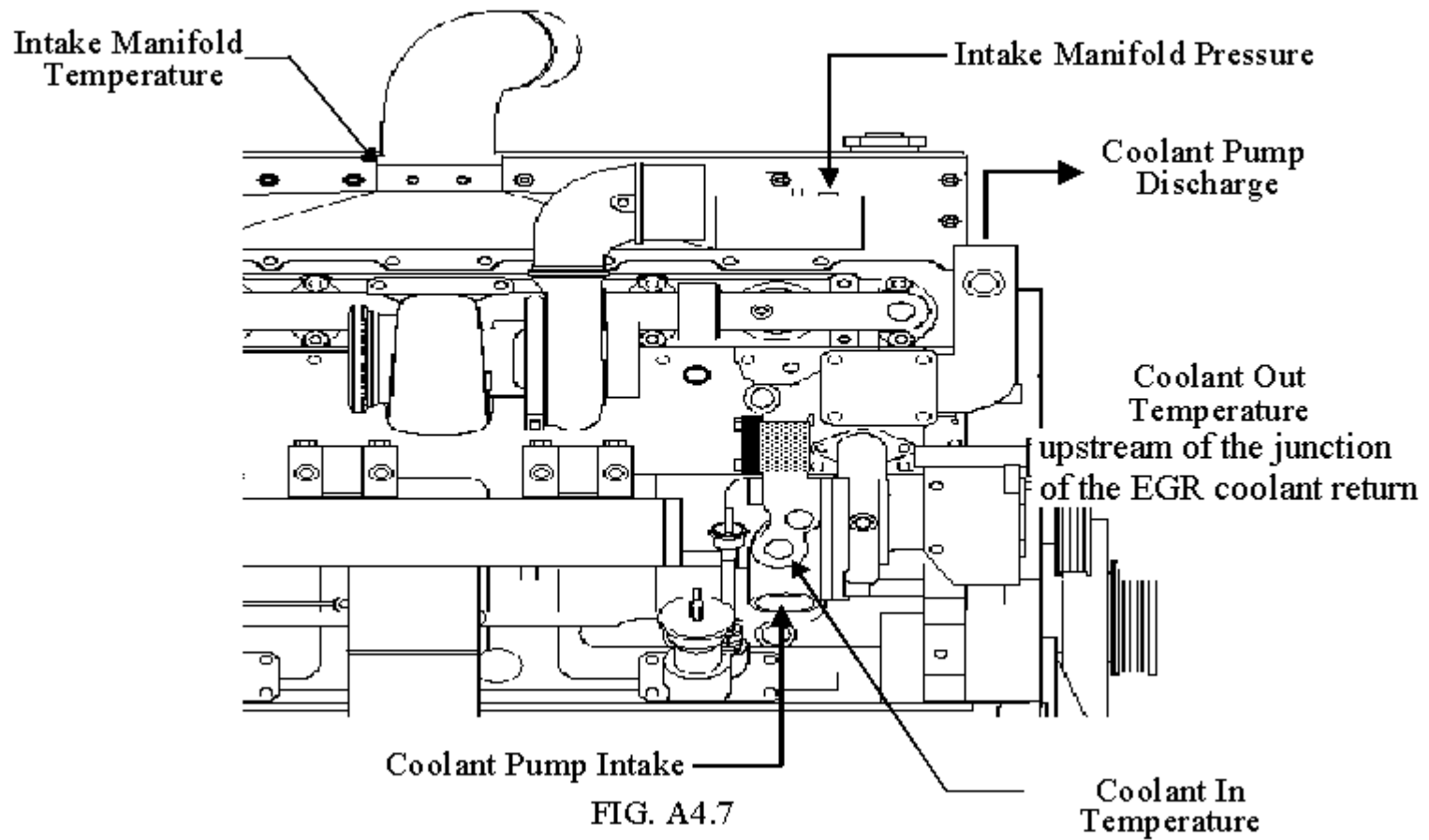

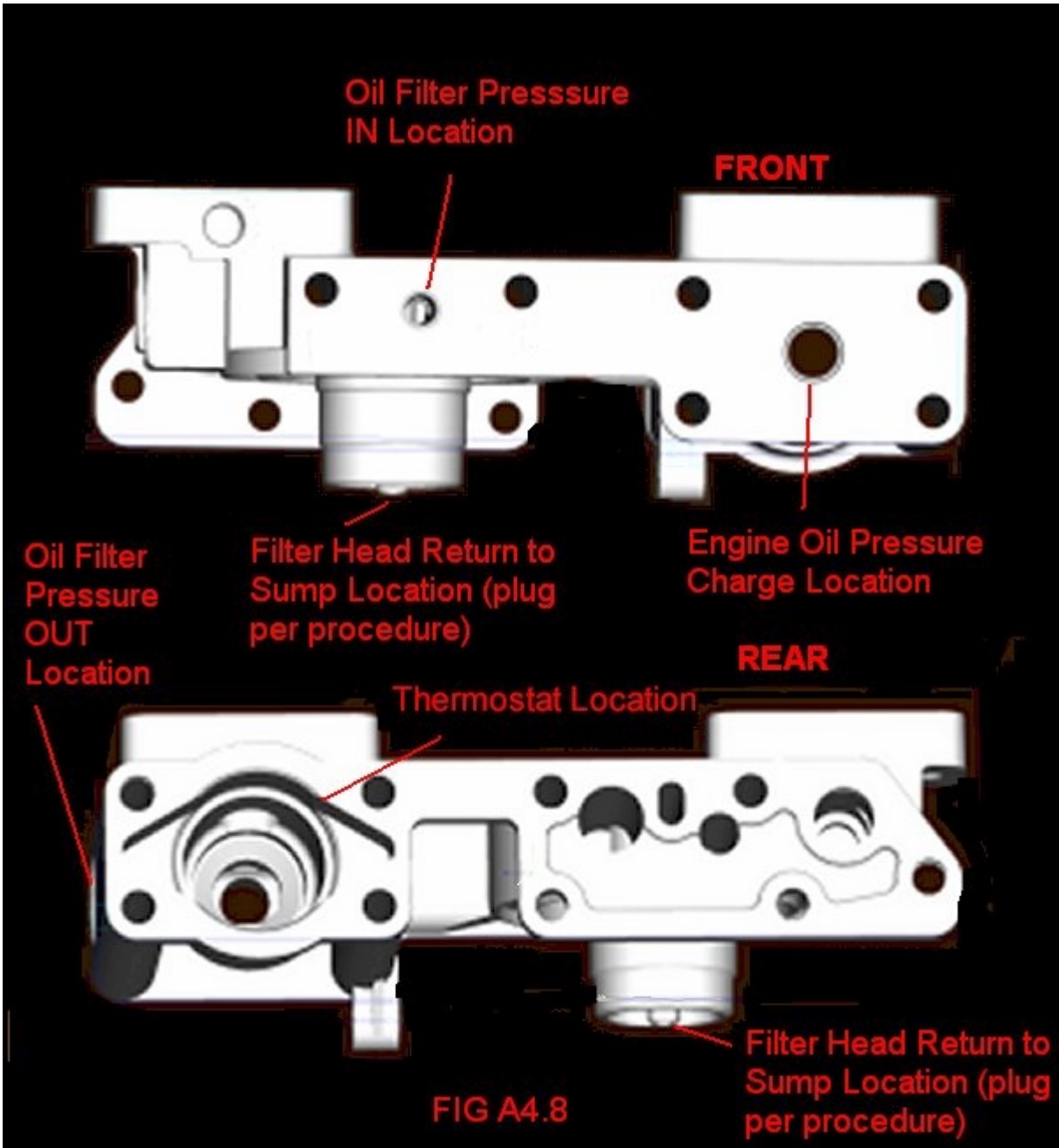

Note: Process water connections
can be reconfigured for laboratory
convenience.

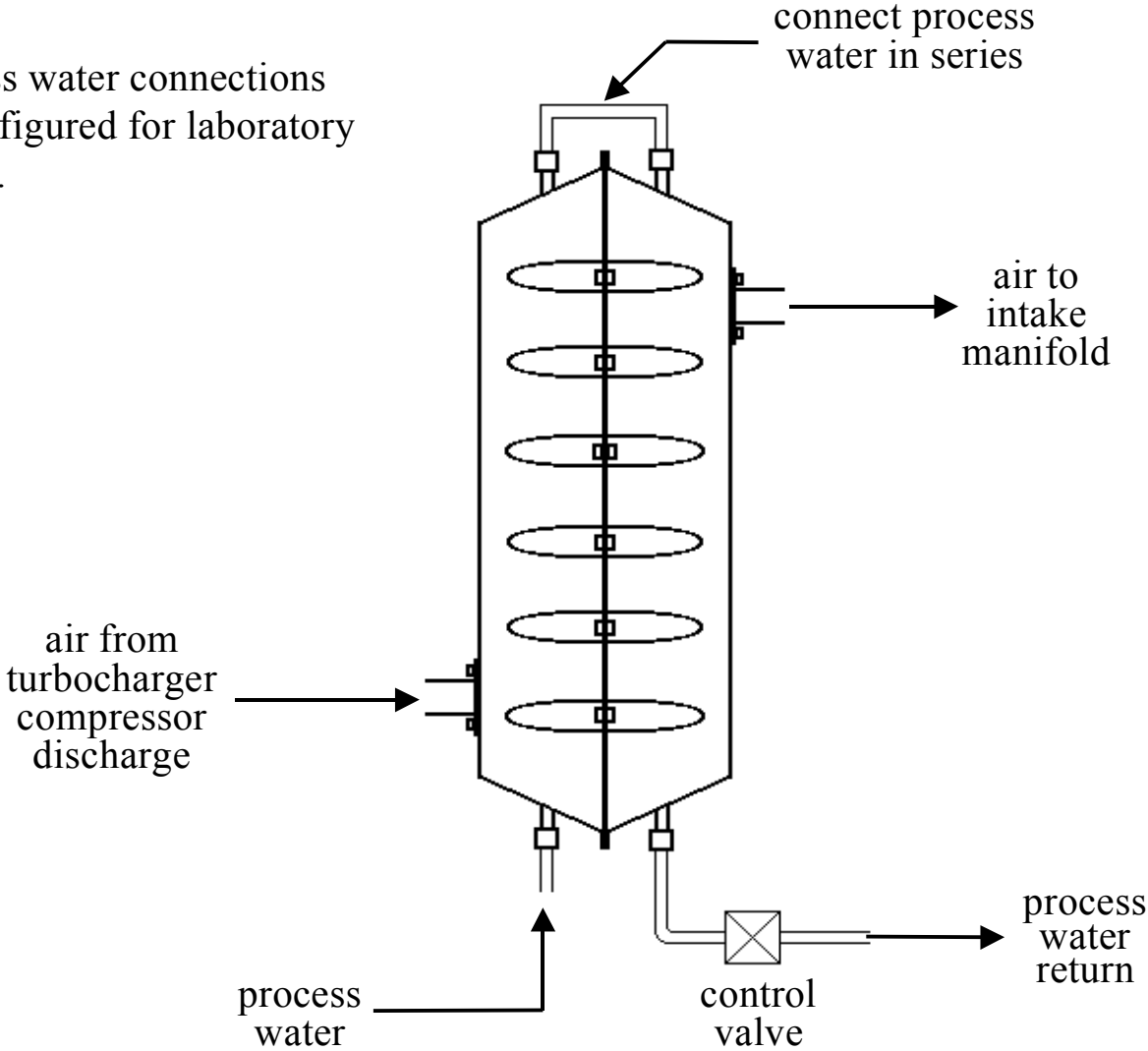
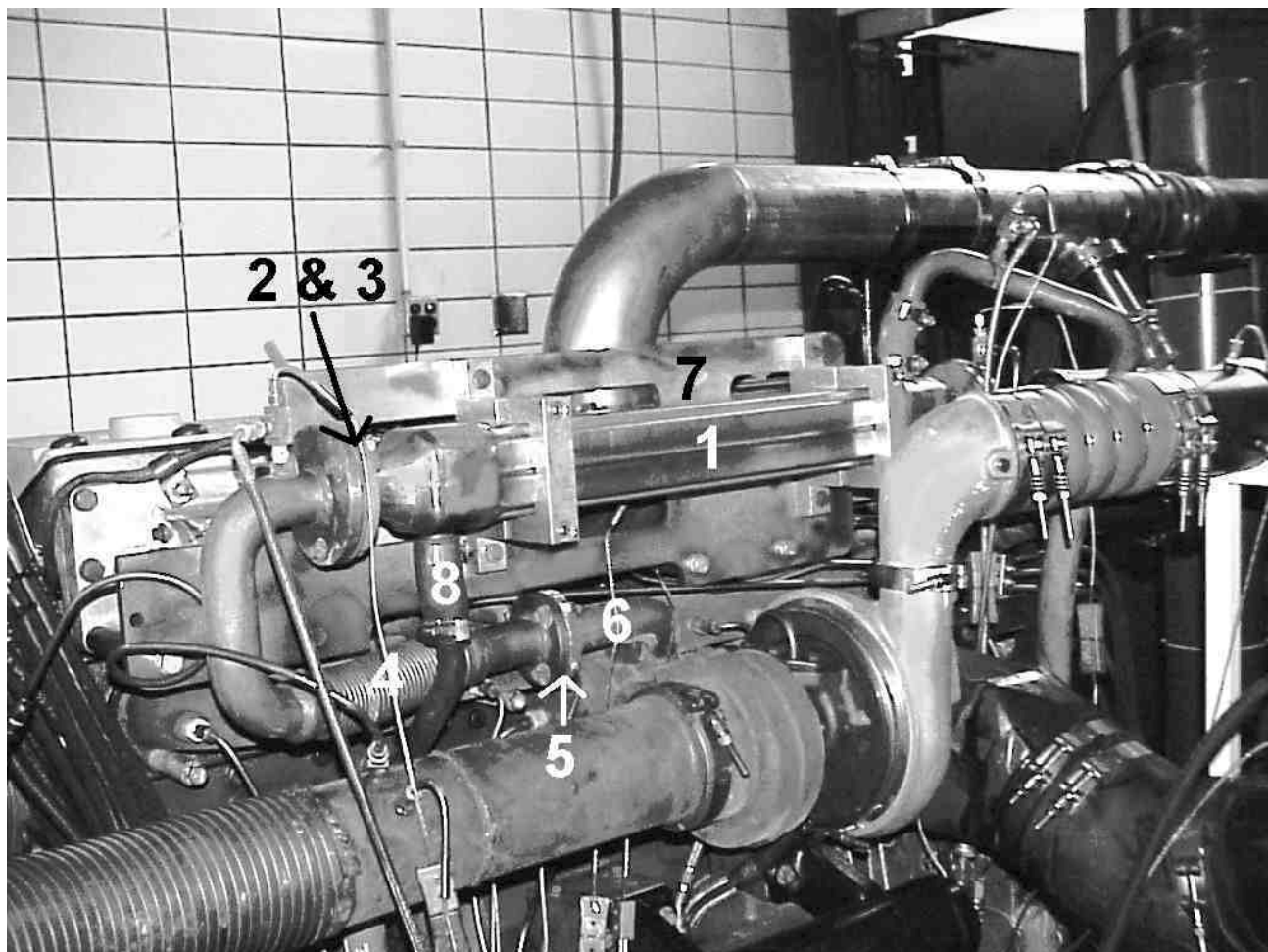

FIG. A4.9



- 1 – P/N Y4006088
- 2 – P/N 3680850
- 3 – Restrictor Plate
- 4 – P/N Y4006151
- 5 – P/N T4006084
- 6 – P/N Y4006116
- 7 – Mounting Plate
- 8 – EGR Coolant In

FIG A4.10



FIG A4.11

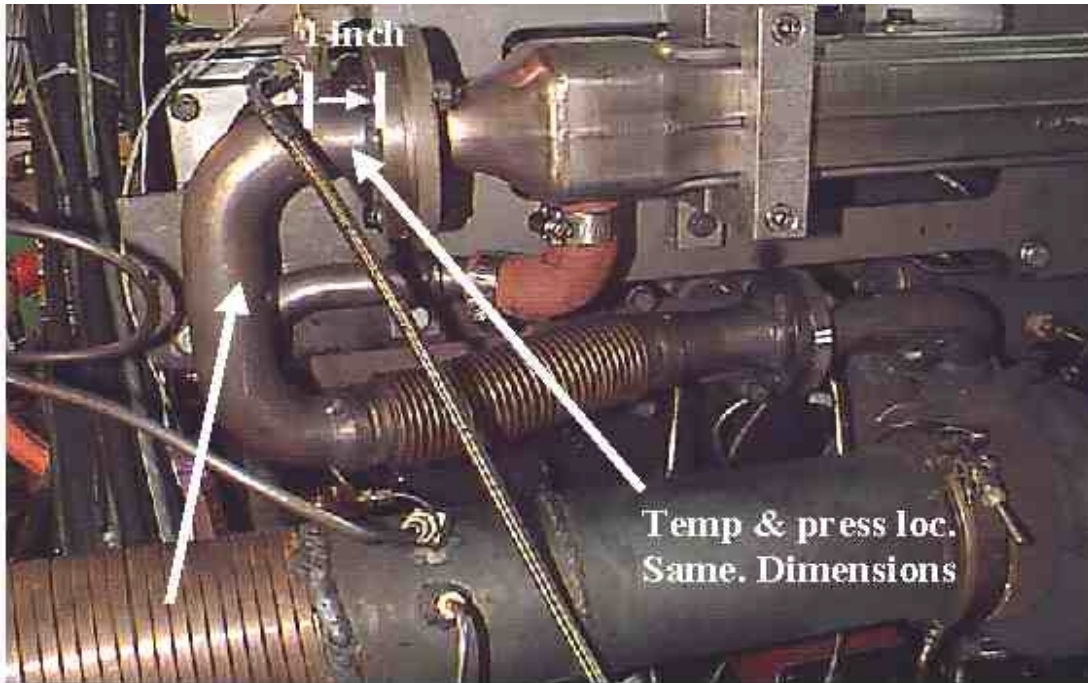

Update on tube from exh. To EGR Cooler pn y4006151
Rev 7/21/99

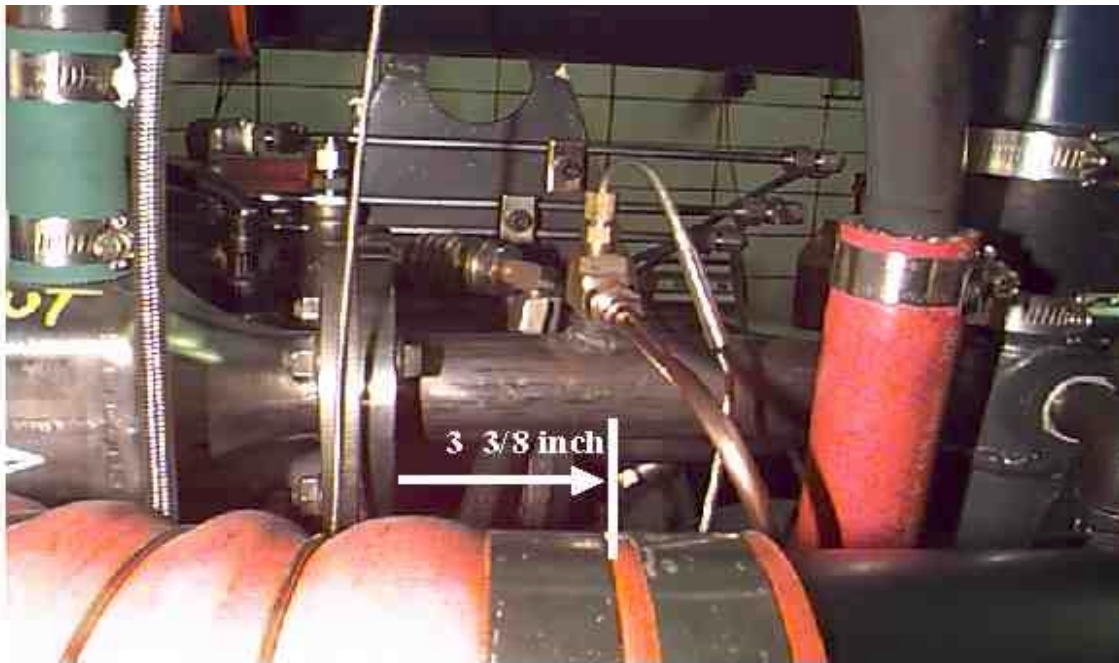

EGR COOLER OUT TEMPERATURE & PRESSURE

FIG A4.12

INTAKE MANIFOLD CO2 PROBE

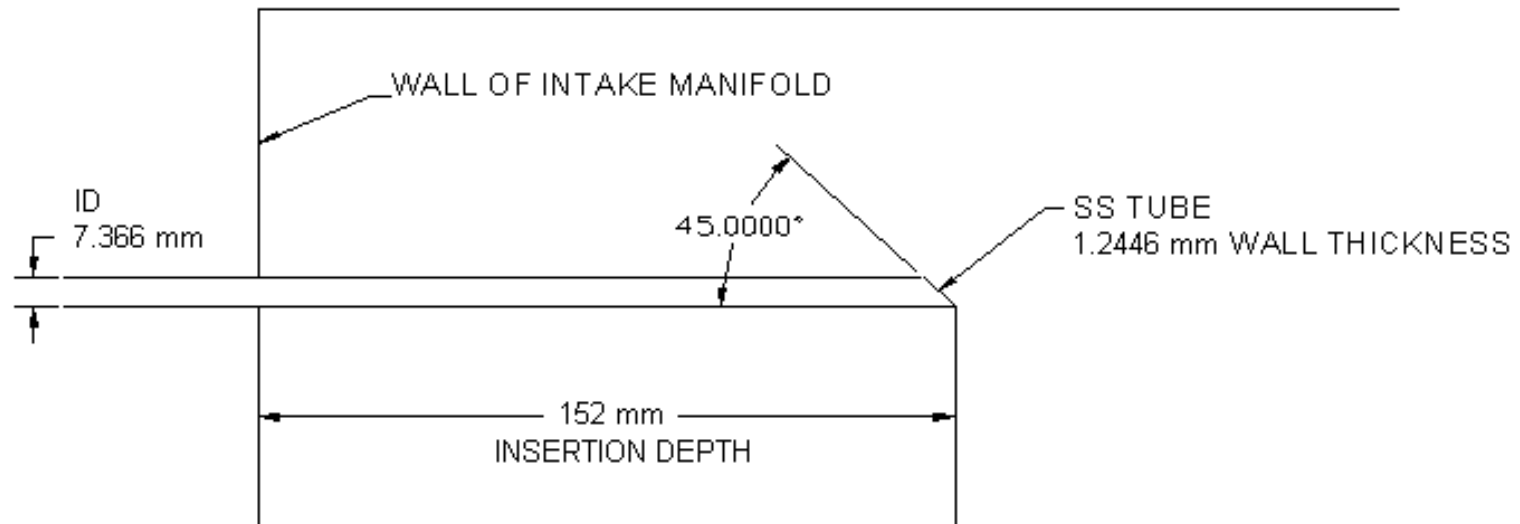

TIP FACES INTAKE MANIFOLD
(away from intake ports)

Probe is installed into the front of the intake manifold behind the engine water outlet

Figure A4.13 Intake Manifold CO2 Probe Diagram

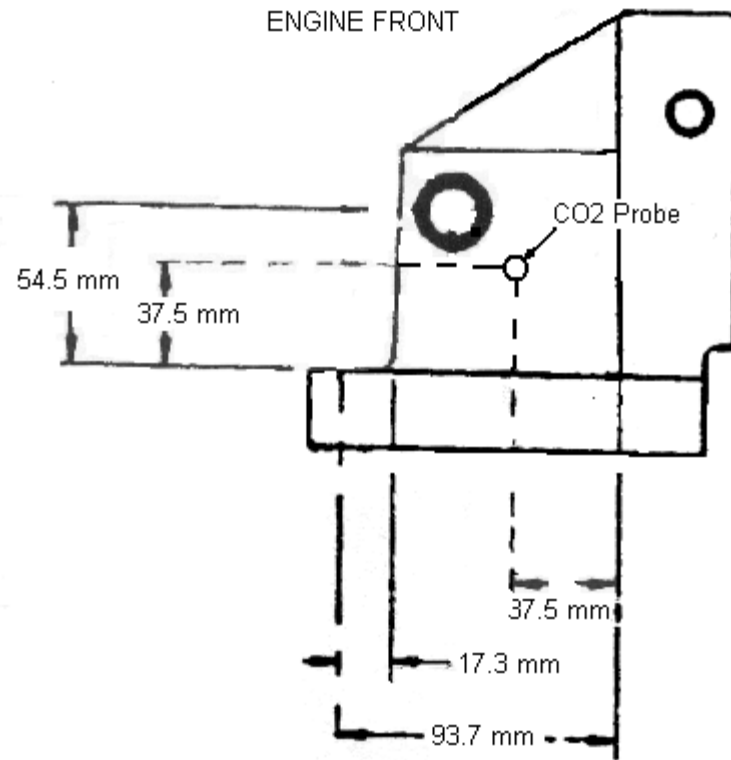

Figure A4.14 Intake Manifold CO2 Probe Location

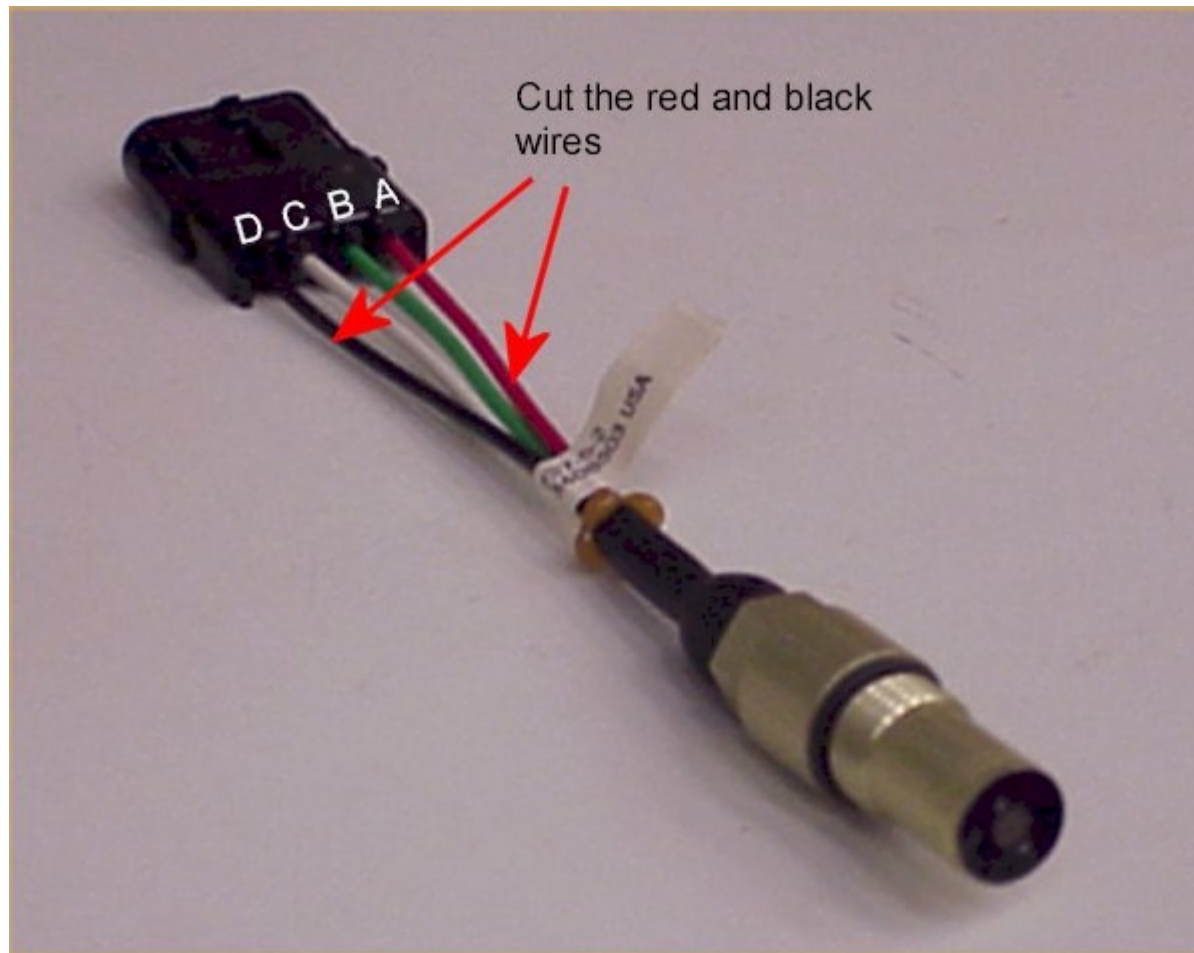

Figure A4.15

A5. EXTERNAL OIL SYSTEM

A5.1 Figure Description:

A5.1.1 External Oil System (Fig. A5.1)

Pump Flowrate:

$P_r = 4 - 8 \text{ L/min (1 - 2 GPM)}$

$P_s = 1.5 * P_r$

Hoses:

Supply - 12 mm (1/2 in.)

Return - 10 mm (3/8 in.)

Vent - 12mm (1/2 in.) minimum

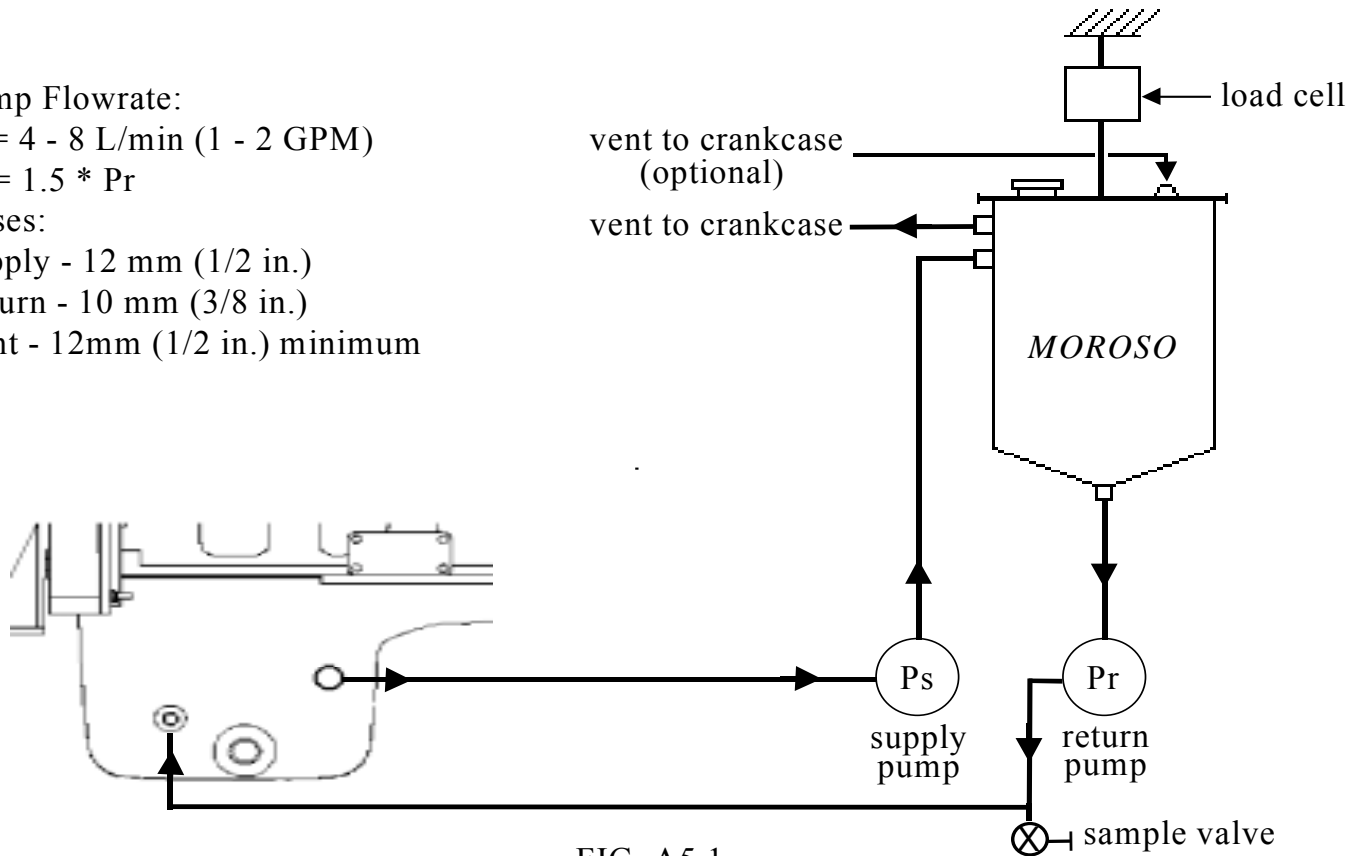

FIG. A5.1

A6. FUEL SPECIFICATION

A7. CUMMINS SERVICE PUBLICATIONS

A7.1 General preparation techniques for Cummins M11 engines are detailed in the Cummins publication titled, Shop Manual - M11 Series Engines, Bulletin No. 3666075-00.

A7.2 Engine specifications, component specifications and torque values can be found in the Cummins publication titled, Specification Manual - M11 Series Engines, Bulletin No. 3666076-00.

A7.3 Troubleshooting and repair information can be found in the Cummins publication titled, Troubleshooting and Repair Manual - M11 Series Engines, Bulletin No. 3666074-00.

A7.4 Valve train overhead adjustments are shown in a video tape titled, N14/L10 Command Select Overhead Adjustments, Bulletin No. 3387746.

A7.5 Information concerning the reuse of overhead components can be found in the Cummins publication titled, Cummins Overhead Reuse Guidelines L-10 Series Engines, Bulletin No. 3810388-00.

A8. SPECIFIED UNITS AND FORMATS

A8.1 Specified Units:

A8.1.1 The parameters in this test method are specified in metric units except for pipe fittings, tubing and tubing fittings, and Compuccheck fittings. Pipe fittings, tubing and tubing fittings are available worldwide and are not interchangeable with metric-sized equivalents because of differences in thread dimensions, therefore, no metric conversion is stated. The Compuccheck fittings are diagnostic ports in the Cummins M11 engine block. The ports are standard straight thread and are not interchangeable with metric-sized equivalents.

A8.1.2 Test Report — Record operational parameters according to Table A8.1. Report test results in the units and with the significant digits shown in Table A8.2. Round test results in

compliance with Practice E29.

A8.1.3 Measurements and Conversions — With the exceptions noted in A8.1.1, all parameters have been specified in S.I. units. The intent of this test method is to measure all parameters directly in S.I. units. If parameters are measured in inch-pound units, then the laboratory shall be able to demonstrate to the TMC that the measurements are within the tolerance after conversion to S.I. units.

Note A8.1: Caution -- Significant error can occur due to rounding or tolerance stacking, or both, when converting from inch-pound units to S.I. units.

Table A8.1 Minimum Resolution of Recorded Measurements

Parameter	Record data to Nearest
Speed	1 r/min
Power	1 kW
Torque	1 N•m
Fuel Flow	0.1 kg/hr
Coolant In Temperature	0.1 °C
Coolant Out Temperature	0.1 °C
Fuel In Temperature	0.1 °C
Oil Gallery Temperature	0.1 °C
Intake Air Temperature	0.1 °C
Exhaust (Tailpipe) Temperature	1 °C
Intake Manifold Pressure	0.1 kPa
Crankcase Pressure	0.01 kPa

Exhaust Pressure	0.1 kPa
EGR Rate	0.01 %

Table A8.2 Significant Digits for Test Results

Parameter	Round off to Nearest
Mass Loss	0.1 mg
Sludge	0.1 merit
Filter Plugging	1 kPa

A8.2 Specification Format — Specifications are listed in three formats: 1) target 2) target and range, and 3) range with no target.

A8.2.1 Target – A target specification has no tolerance, therefore, the only acceptable value is the target. A representative specification format is xx.xx (target). For example, the oil pan oil charge is listed as 24.7 kg.

A8.2.1.1 A parameter with a target shall not be intentionally calibrated or controlled at a level other than the target.

A8.2.2 Target and Range – A target and a range specification implies the correct value is the target and the range is intended as a guide for maximum acceptable variation about the mean. A representative specification format is xx.xx ± x.xx (target ± range). For example, the engine speed is 1800 ± 5 r/min.

Note A8.2: The mean of a random sample should be equivalent to the target. Operation within the range does not imply that parameter will not bias the final test results.

A8.2.3 Range with No Target – A range with no target specification is used when 1) the parameter is not critical and control within the range is sufficient or 2) the measurement technique is not precise, or both. A representative specification format is xx.xx - xx.xx (range_{low} – range_{high}).

For example, the coolant system pressure is 99 – 107 kPa.

A9. PISTON RATING LOCATIONS

Location / Deposit	Special Instructions
Grooves:	
Top Groove Fill	
Second Groove Fill	
Grooves No. 1, No. 3	Rate HC, MC, LC
Groove No. 2	Rate HC, LC
Lands:	
Top Land Heavy Carbon	
Top Land % Flaked Carbon	
Lands No. 1 – No. 4	Rate HC ,LC only
Other:	
Oil Cooling Gallery	Rate separately from grooves and lands
Undercrown	Rate separately from grooves and lands

A10. OIL ANALYSES

Sample Hour	Parameter				
	Metals ^A	TAN ^B	TBN ^C	Vis @ 100 °C ^D	Soot ^E
0	X	X	X	X	X
25	X			X	X
50	X	X	X	X	X
75	X			X	X
100	X	X	X	X	X
125	X	X	X	X	X
150	X	X	X	X	X
175	X	X	X	X	X
200	X	X	X	X	X
225 ^F	X	X	X	X	X
250 ^F	X	X	X	X	X
275 ^F	X	X	X	X	X
300 ^F	X	X	X	X	X

^A D 5185 (Copper, Iron, Lead, Chromium, Aluminum)

^B D 664

^C D 4739 and D 2896

^D D 5967 Annex 3 or D 445

^E D 5967 Annex 4

^F Analyses are for the M11-E

A11. OIL FILTER PLUGGING

A11.1 Figure Description:

A11.1.1 Non-Adjusted ΔP (Fig. A11.1)

A11.1.2 Adjusted ΔP (Fig. A11.2)

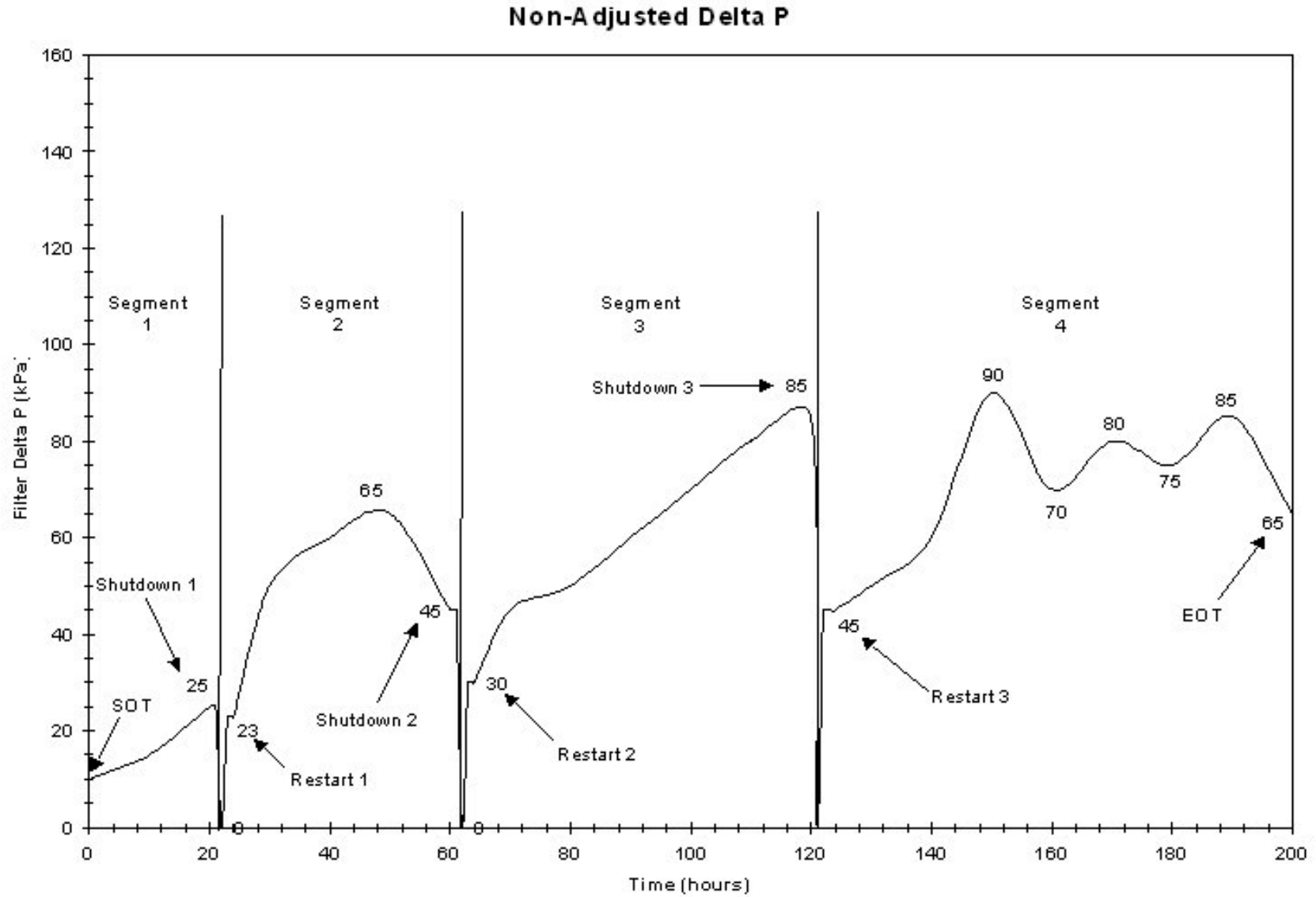

FIG. A11.1

A djusted Delta P
Oil Filter Plugging = 135 kPa

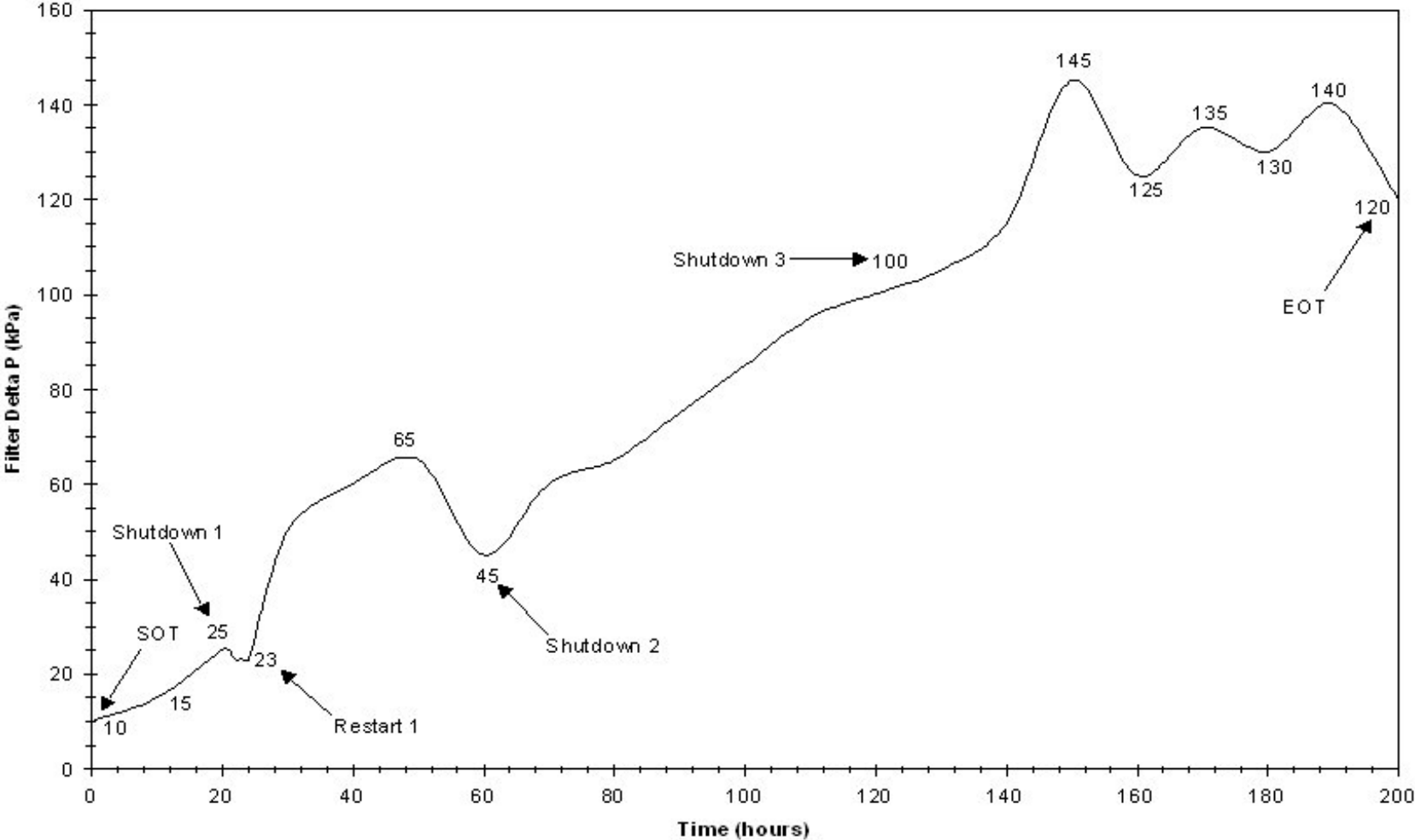

FIG. A11.2

A12. DETERMINATION OF OPERATIONAL VALIDITY

A12.1 Quality Index Calculation

A12.1.1 Calculate Quality Index (QI) for all control parameters according to the DACA II Report. Be sure to account for missing or bad quality data according to the DACA II Report as well.

A12.1.2 Use the U, L, Over Range, and Under Range values shown in Table A14.1 for the QI calculations.

A12.1.3 Round the calculated QI values to the nearest 0.001.

A12.1.4 Report the QI values on Fig. A9.4, Annex A9.

A12.2 Averages

A12.2.1 Calculate the average for control and non-control parameters and report the values in the test report. Note that the averages are not directly used to determine operational validity but they may be helpful when an engineering review is required (refer to section A12.4).

A12.3 Determining Operational Validity

A12.3.1 QI threshold values for operational validity are shown in Table A14.1.

A12.3.1.1 A test with all control parameter QI values greater than or equal to the threshold value is operationally valid.

A12.3.1.2 A test with any control parameter QI value less than the threshold value requires an engineering review to determine operational validity.

A12.4 Engineering Review

A12.4.1 An engineering review is required when a control parameter QI value is below the threshold value. A typical engineering review involves investigation of the test data to determine the cause of the below threshold QI. Affected parameters may also be examined. This can be helpful in determining if a real control problem existed and the possible extent to which it may have impacted the test. For example, a test runs with a low QI for fuel flow. An examination of the fuel flow data may show that the fuel flow data contains several over range values. At this point, an examination of exhaust temperatures may help determine whether the instrumentation problem affected real fuel flow versus affecting only the data acquisition.

A12.4.2 For reference tests, the engineering review shall be conducted jointly with the TMC. For non-reference tests, optional input is available from the TMC for the engineering review.

A12.4.2 Determine operational validity based upon the engineering review and summarize the decision in the comment section in the test report. It may be helpful to include any supporting documentation at the end of the test report. The final decision regarding operational validity rests with the laboratory.

**TABLE A12.1
QUALITY INDEX CALCULATION VALUES**

Control Parameter	Units	Quality Index Threshold	Quality Index U & L Values				Over & Under Range Values	
			U		L		Low	High
Speed ^A	r/min	0.000	1802.5	1602.5	1797.5	1597.5	1489	1911
Fuel Flow ^A	kg/h	0.000	53.5		52.5		31	75
Coolant Out Temp.	°C	0.000	89.0		87.0		44	132
Fuel In Temp.	°C	0.000	40.6		39.4		14	66
Oil Gallery Temp.	°C	0.000	115.7		114.3		84	146
Intake Manifold Temp.	°C	0.000	46.6		45.4		20	72
Exhaust Back Pressure	kPa	0.000	107.6		106.4		81	133

^AU and L values for speed are split by test stage.

APPENDIXES

(Non Mandatory Information)

X1. Non-Mandatory Suppliers List:

X1.1 Available from a Cummins parts distributor.

X1.2 Available from the CPD listed below:

Test Engineering, Inc.

12758 Cimarron Path, Suite 102

San Antonio, TX 78249-3417

Phone: (210) 690-1958

Fax:(210) 690-1959

Table X1.2 Non-Kit Parts Available from the CPD

Description	Cummins P/N	Critical Part
EGR Cooler	Y4006088	Y
Tube – Exhaust Manifold to EGR Cooler, In	Y4006151	Y
Mounting Plate	Y4006095	Y
Tube from EGR Cooler to Intake Pipe	Y4006115	Y
Cylinder Head	4004086	Y
Injector	3411753	Y
Turbocharger	V00382 HX52	Y
Engine Block w/ disabled capacitors	3329058	Y
Timing Sensor	3078151	Y
Cam Shaft	3084568	Y
Gear Housing	3895536	Y

X1.3 The modified oil pan and the oil heat exchanger adapter blocks can be obtained from:

Southwest Research Institute

P.O. Drawer 28510

San Antonio, TX 78228

Phone (210) 522-3567

Fax (210) 522-5913

X1.4 The Moroso oil tank (P/N 22660) can be obtained from:

Moroso Performance Products Inc.

80 Carter Dr.

P.O.Box 1470

Guilford, CT 06437

Phone (203) 453-6571

Fax (203) 453-6906

X.1.5 The Modine aftercooler (P/N 1A012865) can be obtained from:
Modine

X2. Typical System Configurations:

X2.1 Intake Air System (Fig. X2.1)

X2.2 Fuel System (Fig. X2.2)

X2.3 Coolant System (Fig X2.3)

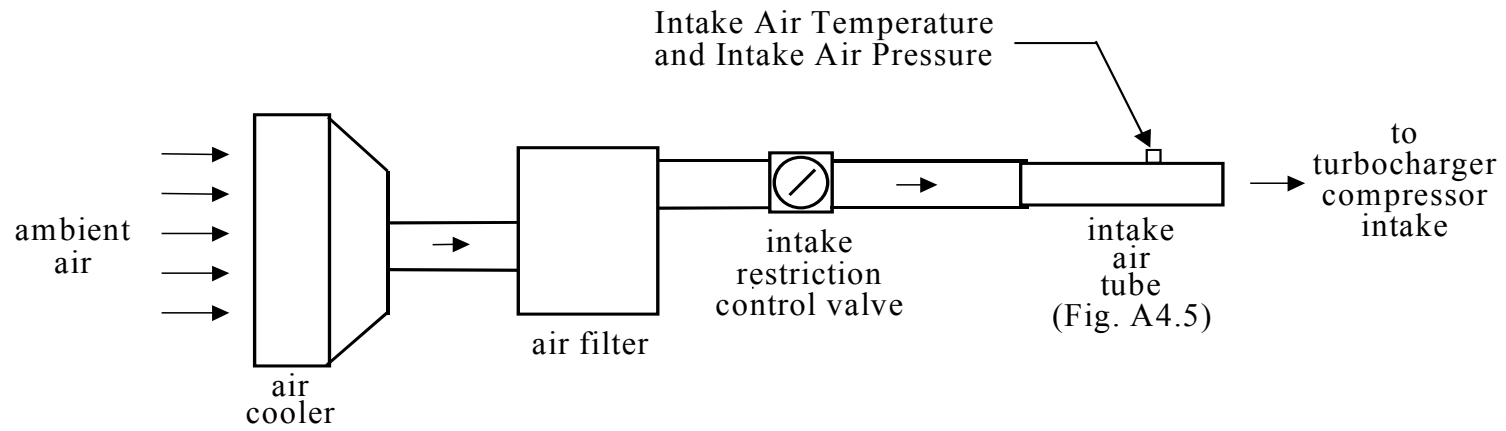
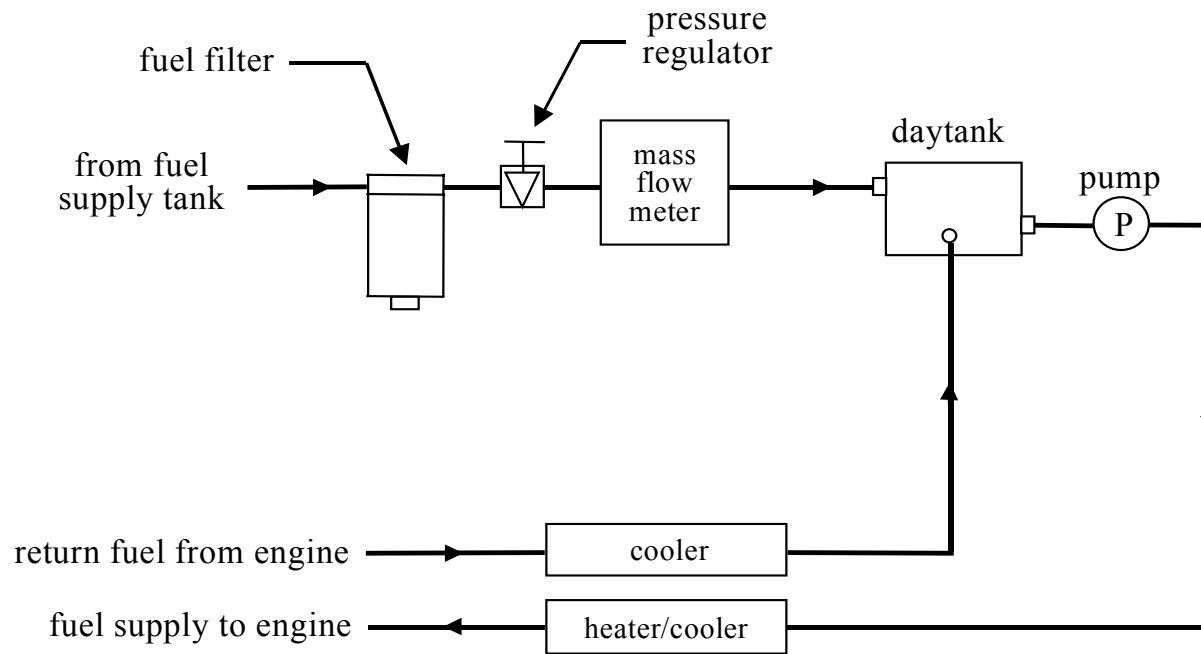

FIG. X2.1



Heating or cooling, or both, may be necessary to maintain fuel temperature.

FIG. X2.2

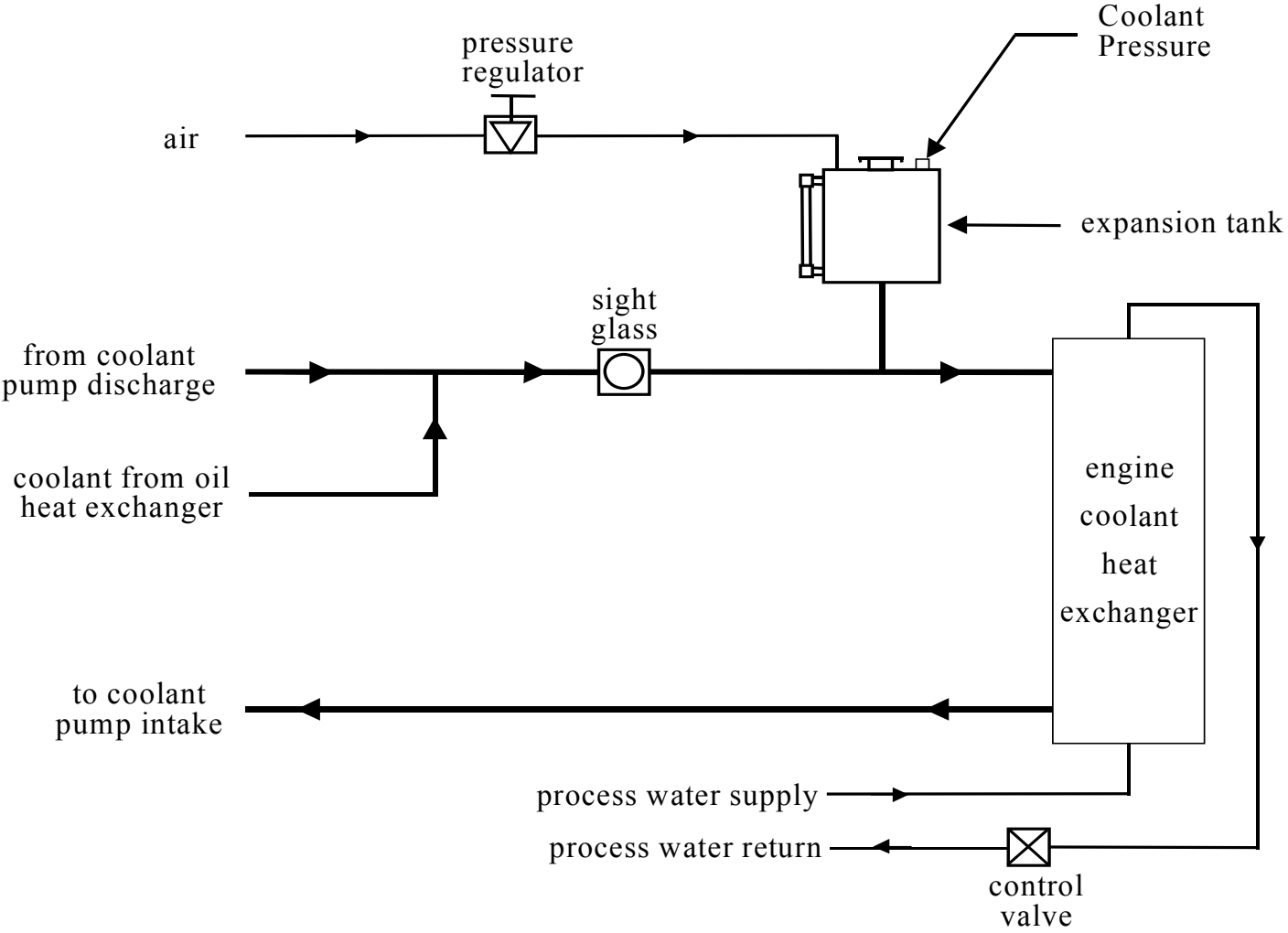

FIG. X2.3

Cummins M11 Footnotes

¹ This test method is under the jurisdiction of ASTM Committee D02 on Petroleum Products and Lubricants and is the direct responsibility of Subcommittee D02.0B on Automotive Lubricants. Current edition approved XXX. Published YYYY.

² American Society for Testing and Materials takes no position respecting the validity of any patent rights asserted in connection with any item mentioned in this standard. Users of this standard are expressly advised that determination of the validity of any such patent rights, and the risk of infringement of such rights, are entirely their own responsibility.

³ The ASTM Test Monitoring Center will update changes in this test method by means of Information Letters. Information letters may be obtained from the ASTM Test Monitoring Center, 6555 Penn Avenue, Pittsburgh, PA 15206-4489, Attention: Administrator.

⁴ Annual Book of ASTM Standards, Vol 05.01

⁵ Annual Book of ASTM Standards, Vol 05.04

⁶ Annual Book of ASTM Standards, Vol 05.02

⁷ Annual Book of ASTM Standards, Vol 05.03

⁸ Annual Book of ASTM Standards, Vol 14.02

⁹ Annual Book of ASTM Standards, Vol 14.03

¹⁰ Available from the Coordinating Research Council, Inc., 219 Perimeter Parkway, Atlanta, Georgia 30346.

¹¹ Available from ASTM, 100 Barr Harbor Drive, West Conshohocken, PA 19428-2959.

¹² Available from the ASTM Test Monitoring Center, 6555 Penn Avenue, Pittsburgh, PA 15206-4489, Attention: Administrator.

¹³ Available from a Cummins parts distributor

¹⁴ ASTM Test Monitoring Center, 6555 Penn Avenue, Pittsburgh, PA 15206-4489 Phone: (412) 365-1000, Fax: (412) 365-1047