

This document is not an ASTM standard; it is under consideration within an ASTM technical committee but has not received all approvals required to become an ASTM standard. You agree not to reproduce or circulate or quote, in whole or in part, this document outside of ASTM Committee/Society activities, or submit it to any other organization or standards bodies (whether national, international, or other) except with the approval of the Chairman of the Committee having jurisdiction and the written authorization of the President of the Society. If you do not agree with these conditions please immediately destroy all copies of the document. Copyright ASTM International, 100 Barr Harbor Drive, West Conshohocken, PA 19428. All Rights Reserved.



INTERNATIONAL Designation: DXXXX

Date: <Enter Date>
To: Subcommittee D02.0B
Tech Contact: Terry Bates, batesterryw@aol.com, +441513421193
Work Item #: WK 51937
Ballot Action: New test method

Rationale: This method, commonly referred to as the Caterpillar C13 Engine Oil Aeration Test, defines a test procedure for a heavy-duty diesel engine operated under high-idle conditions to evaluate engine oil performance with regards to engine lubricant aeration. The method forms part of PC-11 the heavy-duty diesel engine oil category.

Note: This document is a draft procedure submitted for consideration by ASTM and the appropriate sub committees and groups for use in the development of a new ASTM standard. Modifications to this procedure will be made throughout development before being accepted.

Prepared by: Terry Bates

Standard Test Method for Evaluation of Engine Oil Aeration Resistance in a Caterpillar C13 Direct-Injected Turbocharged Automotive Diesel Engine¹¹

This standard is issued under the fixed designation DXXXX; the number immediately following the designation indicates the year of original adoption or, in the case of revision, the year of last revision. A number in parentheses indicates the year of last reapproval. A superscript epsilon (ϵ) indicates an editorial change since the last revision or reapproval.

¹ This test method is under the jurisdiction of ASTM Committee D02 on Petroleum Products, Liquid Fuels, and Lubricants and is the direct responsibility of Subcommittee D02.B0.02 on Heavy-Duty Engine Oils. Current edition approved XXXX. Published YYYY.

INTRODUCTION

Portions of this test method are written for use by laboratories that make use of ASTM Test Monitoring Center (TMC)² services (see [Annex A1](#)).

The TMC provides reference oils, and engineering and statistical services to laboratories that desire to produce test results that are statistically similar to those produced by laboratories previously calibrated by the TMC.

In general, the Test Purchaser decides if a calibrated test stand is to be used. Organizations such as the American Chemistry Council require that a laboratory utilize the TMC services as part of their test registration process. In addition, the American Petroleum Institute and the Gear Lubricant Review Committee of the Lubricant Review Institute (SAE International) require that a laboratory use the TMC services in seeking qualification of oils against their specifications.

The advantage of using the TMC services to calibrate test stands is that the test laboratory (and hence the Test Purchaser) has an assurance that the test stand was operating at the proper level of test severity. It should also be borne in mind that results obtained in a non-calibrated test stand may not be the same as those obtained in a test stand participating in the ASTM TMC services process.

1. Scope

1.1 This test method evaluates an engine oil's resistance to aeration in automotive diesel engine service. It is commonly referred to as the Caterpillar-C13 Engine Oil Aeration Test (COAT). The test is conducted under high-engine-speed (1800 r/min), zero load idling conditions using a specified Caterpillar 320 kW, direct-injection, turbocharged, after-cooled, six-cylinder diesel engine designed for heavy-duty, on-highway truck use. This test method was developed as a replacement for Test Method D6894.

Comment [TB1]: Idling is zero load, low speed and so is incorrect term here for zero load, high speed. Have replaced "idling" by "1 zero load" throughout.

NOTE 1—Companion test methods used to evaluate engine oil performance for specification requirements are discussed in the latest revision of Specification [D4485](#).

1.2 The values stated in SI units are to be regarded as standard. No other units of measurement are included in this standard.

1.2.1 *Exception*—Where there is no direct SI equivalent, for example, screw threads, national pipe threads/diameters, and tubing size.

1.3 *This standard does not purport to address all of the safety concerns, if any, associated with its use. It is the responsibility of the user of this standard to establish appropriate safety and health practices and determine the applicability of regulatory limitations prior to use. See [Annex A2](#) for general safety precautions.*

1.4 This test method is arranged as follows:

	Section
Scope	1
Referenced Documents	2

² ASTM Test Monitoring Center, 6555 Penn Avenue, Pittsburgh, PA 15206-4489. <http://www.astmtmc.cmu.edu>.

Terminology	3	
Summary of Test Method	4	
Significance and Use	5	
Apparatus	6	
Engine Liquids and Cleaning Solvent	7	
Preparation of Apparatus	8	
Engine Stand Calibration and Non-Reference Oil Tests	9	
Procedure	10	
Calculation, Test Validity and Test Results	11	
Report	12	
Precision and Bias	13	
Keywords	14	
ASTM Test Monitoring Center Organization		Annex A1
Safety Precautions		Annex A2
Engine and Engine Build Parts Kit		Annex A3
Oil Temperature Control System		Annex A4
Engine Modification's and Instrumentation		Annex A5
External Oil System		Annex A6
Aeration Measurement System		Annex A7
Specified Units and Formats		Annex A8
ASTM TMC: Calibration Procedures		Annex A9
ASTM TMC: Maintenance Activities		Annex A10
ASTM TMC: Related Information		Annex A11
Engine Break-in and Silicon Passivation Procedure		Annex A12
Criteria for recalibrating FDM		Annex A13
Schedule for Taking Oil Samples and Carrying out Analyses		Annex A14
Determination of Operational Validity		Annex A15
Typical System Configuration		Appendix X1

Comment [TB2]: This Annex has yet to be written **A13**

Comment [sam3]: This item is still to be determined by the task force. I suspect it will be removed.

2. Referenced Documents

2.1 ASTM Standards:³

[D235 Specification for Mineral Spirits \(Petroleum Spirits\) \(Hydrocarbon Dry Cleaning Solvent\)](#)

[D445 Test Method for Kinematic Viscosity of Transparent and Opaque Liquids \(and Calculation of Dynamic Viscosity\)](#)

[D3524 Test Method for Diesel Fuel Diluent in Used Diesel Engine Oils by Gas Chromatography](#)

[D4052 Test Method for Density, Relative Density, and API Gravity of Liquids by Digital](#)

³ For referenced ASTM standards, visit the ASTM website, www.astm.org, or contact ASTM Customer Service at service@astm.org. For *Annual Book of ASTM Standards* volume information, refer to the standard's Document Summary page on the ASTM website.

Density Meter

D4485 Specification for Performance of Active API Service Category Engine Oils

D5185 Test Method for Multielement Determination of Used and Unused Lubricating Oils and Base Oils by Inductively Coupled Plasma Atomic Emission Spectrometry (ICP-AES)

D6894 Test Method for Evaluation Aeration Resistance of Engine Oils in Direct-Injected Turbocharged Automotive Diesel Engine

D7549 Test Method for Evaluation of Heavy-Duty Engine Oils under High Output Conditions—Caterpillar C13 Test Procedure

E29 Practice for Using Significant Digits in Test Data to Determine Conformance with Specifications

3. Terminology

3.1 Definitions:

3.1.1 *automotive, adj*—descriptive of equipment associated with self-propelled machinery, usually vehicles driven by internal combustion engines. **D4175**

3.1.2 *calibrate, v*—to determine the indication or output of a measuring device or a given engine with respect to a standard. **D4175**

3.1.3 *calibrated test stand, n*—a test stand on which the testing of reference material(s), conducted as specified in the standard, provided acceptable test results.

3.1.3.1 *Discussion*—In several automotive lubricant standard test methods, the ASTM Test Monitoring Center provides testing guidance and determines acceptability. **D4175**

3.1.4 *blowby, n*—in internal combustion engines, that portion of the combustion products and unburned air/fuel mixture which leaks past piston rings into the engine crankcase during operation. **D4175**

3.1.5 *candidate oil, n*—an oil that is intended to have the performance characteristics necessary to satisfy a specification and is to be tested against that specification.

3.1.5.1 *Discussion*—These oils are mainly submitted for testing as *candidates* to satisfy a specified performance; hence the designation of the term. **3.1.7D4175**

3.1.6 *engine oil, n*—a liquid that reduces friction or wear, or both, between the moving parts within an engine; removes heat particularly from the underside of pistons; and serves as combustion gas sealant for the piston rings.

3.1.6.1 *Discussion*—It may contain additives to enhance certain properties. Inhibition of engine rusting, deposit formation, valve train wear, oil oxidation, and foaming are examples. **D4175**

3.1.7 *foam, n*—in liquids, a collection of bubbles formed in the liquid or on (at) its surface in which the air (or gas) is the major component on a volumetric basis. **D4175**

3.1.8 *heavy-duty engine, n*—in internal combustion engine types, one that is designed to allow operation continuous at or close to its peak output.

3.1.8.1 *Discussion*—This type of engine is typically installed in large trucks and buses as well as farm, industrial, and construction equipment. **D4175**

Comment [HA4]: Best to remove (at) per 3.2.1below

3.1.9 lubricant, n—any material interposed between two surfaces that reduces the friction or wear, or both, between them. **D4175**

3.1.10 lubricant test monitoring system (LTMS), n—an analytical system in which ASTM calibration test data are used to manage lubricant test precision and severity (bias). **D4175**

LTMS date, n—the date the test was completed unless a different date is assigned by the TMC.

LTMS time, n—the time the test was completed unless a different time is assigned by the TMC.

3.1.11 non-reference oil, n—any oil other than a reference oil; such as a research formulation, commercial oil, or candidate oil. **D4175**

3.1.12 quality index (OI), n—a mathematical formula that uses data from controlled parameters to calculate a value indicative of control performance. **D4175**

3.1.13 reference oil, n—an oil of known performance characteristics, used as a basis for comparison.

3.1.13.1 Discussion—Reference oils are used to calibrate testing facilities, to compare the performance of other oils, or to evaluate other materials (such as seals) that interact with oils.

D4175

3.1.14 test oil, n—any oil subjected to evaluation in an established procedure.

3.1.14.1 Discussion—It can be any oil selected by the laboratory conducting the test. It could be an experimental product or a commercially available oil. Often it is an oil that is a candidate for approval against engine oil specifications (such as manufacturers' or military specifications, and so forth). **D4175**

3.2 Definitions of Terms Specific to This Standard:

3.2.1 aeration, n—in liquids, the action of impregnating with air that forms foam bubbles in or on the surface of a liquid or is entrained as a dispersion in that liquid.

3.2.2 flush, n—the action of cleaning out the engine oil system using new test oil to remove any residues as well as to minimize possible carryover effect from the previous test oil.

3.2.3 mass fraction, n—of a component A in a solution, mass of component A divided by the total mass of all the constituents of the solution.

3.2.4 volume fraction, n—of a component B in a solution, volume of component B divided by the total volume of the all the constituents of the solution prior to mixing.

3.3 Abbreviations and Acronyms:

3.3.1 ACERT—Advanced Combustion Emission Reduction Technology

3.3.2 BOT—Beginning of Test

[3.3.3 Cat⁴—abbreviation for Caterpillar](#)

[3.3.4 COAT—Caterpillar-C13 Oil Aeration Test](#)

[3.3.5 ELC⁵—Extended Life Coolant](#)

[3.3.6 EOAT—Engine Oil Aeration Test](#)

[3.3.7 ET—Engine Technician](#)

[3.3.8 EOT—End of Test](#)

[3.3.9 FDM—Flow and Density Meter](#)

[3.3.10 ICP-AES—Inductively Coupled Plasma Atomic Emission Spectrometry](#)

[3.3.11 ID—Internal Diameter](#)

[3.3.12 LTMS—Lubricant Test Monitoring System](#)

[3.3.13 NPT— National Pipe Thread](#)

[3.3.14 OA—Oil Aeration](#)

[3.3.15 P—Pressure](#)

[3.3.16 P/N—Part Number \(applies only to parts sourced from Caterpillar\)](#)

[3.3.17 QI—Quality Index](#)

[3.3.18 T—Temperature](#)

[3.3.179 TMC—Test Monitoring Center of ASTM](#)

4. Summary of Test Method

4.1 This test method uses a production Caterpillar C13 diesel engine. It is installed on a stand equipped with appropriate instrumentation to record and control various operating parameters. This test is run on an engine that is built with new components and then used for multiple oil evaluations until operational conditions or aeration performance are impacted by the engine condition.

4.2 The test operation involves two test oil flushes of 35 min duration for each test, a test warm-up for 35 min, a baseline reference period for 5 min and then a test length of 50 h at high-engine-speed (1800 r/min), zero load conditions.

4.3 The percent aeration of the engine oil is determined using a flow and density meter to continuously monitor the density of a small portion of diverted gallery oil flow that has controlled pressure, temperature, and flow rate. The density of this oil is used to calculate the percentage of total sample volume that is entrained air.

5. Significance and Use

⁴ [Registered trademark of Caterpillar Inc., 100 North East Adams St., Peoria, IL 61629.](#)

⁵ [Trade mark of Caterpillar Inc., 100 North East Adams St., Peoria, IL 61629.](#)

5.1 *Background*—Prior to this test, the ability of an engine lubricant to resist aeration was measured by Test Method D6894. A study carried out by Caterpillar indicated that this test no longer correlated with the field. There were also concerns about the reliability of the volume aeration measurement and the continued availability of the engine. The Caterpillar C13 EOAT was developed, therefore, to provide a better measurement of the ability of a lubricant to resist aeration during engine operation in field service.

5.2 *Test Method*—This test method evaluates aeration performance under high-engine-speed, zero load operation in a turbocharged, heavy-duty, four-stroke diesel engine.

5.3 *Use:*

5.3.1 The tendency of engine oils to aerate in direct-injection, turbocharged diesel engines is influenced by a variety of factors, including engine oil formulation, oil temperature, sump design and capacity, residence time of the oil in the sump, and the design of the pressurized oil systems. In some engine-oil-activated systems, the residence time of the oil in the sump is insufficient to allow dissipation of aeration from the oil. As a consequence, aerated oil can be circulated to hydraulically activated components, adversely affecting the engine timing characteristics and engine operation.

5.3.2 The results from this test method may be compared against specification requirements such as D4485 to ascertain acceptance.

5.3.3 The design of the test engine used in this test method is representative of many, but not all, diesel engines. This factor, along with the unique operating conditions, needs to be considered when comparing the test results against specification requirements.

6. Apparatus

6.1 *Test Stand*—The test stand consists of the test engine and the aeration measurement system.

6.1.1 *Test Engine*—The test engine is a production 2004 Caterpillar 320 kW C13 engine^{6,7}, designed for heavy-duty, on-highway truck use. It is an electronically controlled, turbocharged, after-cooled, direct-injected, six-cylinder diesel engine with an in-block camshaft and a four-valve per cylinder arrangement. The engine uses Caterpillar's ACERT technology featuring multiple injections per cycle and inlet-valve-actuation control. It features a 2004 US EPA emissions configuration with electronic control of fuel metering, fuel injection timing and inlet valve actuation timing. See Annex A3 for the source of the test engine and critical and non-critical parts.

6.1.2 *Aeration Measurement System*—The aeration measurement system uses the density measurement to calculate the percent entrained air volume within the engine oil at a given pressure and temperature. The system utilizes a coriolis-based flow and density meter (FDM) capable of measuring density to less than 1 kg/m³. The calculation of the percent aeration is based on the difference in density between an un-aerated oil sample (measured by Test Method

Comment [TB5]: Is there a reference for this study

Comment [sam6]: Hind will have to supply this study.

Comment [HA7]: Would it be better to state instead of "better": "more reliable" measurement.. Also, can we add a sentence stating "The engine used is of current technology and the aeration measurement is operator independent."

⁶ The sole source of supply of the apparatus known to the committee at this time is Caterpillar Inc., 100 North East Adams St., Peoria, IL 61629.

⁷ If you are aware of alternative suppliers, please provide this information to ASTM International Headquarters. Your comments will receive careful consideration at a meeting of the responsible technical committee¹ which you may attend.

D4052) and the density of the aerated oil during the test measured by the FDM. The aeration measurement system comprises a heated line, a pressure-control valve, the FDM, a variable-speed pump, and pressure transducers and thermocouples. Assemble the system with the indicated line lengths, fittings and components as shown in Annex A7. The aeration measurement system is enclosed in a cabinet capable of maintaining the internal temperature at 50 °C regardless of ambient temperatures. This temperature is typically maintained by an internal heater and insulation within the cabinet. Include the FDM, FDM-inlet and -outlet thermocouples and pressure transducers in the enclosure.

6.2 Test Engine Configuration:

6.2.1 *Oil Heat Exchanger and Oil Heat System*—Replace the standard Caterpillar oil heat exchanger core with a stainless steel core, Caterpillar P/N 1Y-4026^{6,7}. Additionally install a remotely mounted heat exchanger. Control the oil temperature with a dedicated cooling loop and control system which is separate from the engine coolant (see [Annex A4](#)). Ensure that the oil cooler bypass valve is blocked closed.

NOTE 2—In subsequent text, P/N denotes the part number for parts sourced from Caterpillar. Footnotes 6 and 7 apply.

6.2.2 *Oil Pan Modification*—Modify the oil pan as shown in [Figs. A5.1 to A5.4](#).

6.2.3 *Engine Control Module (ECM)*—The ECM defines the desired engine fuel timing and quantity. It also limits maximum engine speed and power. Caterpillar electronic governors are designed to maintain a speed indicated by the throttle position signal. Speed variation drives fuel demand (rack). Rack and engine speed are input to the injection duration and timing maps to determine duration and timing commands for the fuel injectors. Obtain special oil test engine control software (module P/N 250-6775-03) for correct maps. Contact the Caterpillar oil test representative through TMC for installation of this software. Use the Caterpillar engine technician (ET) service software package, version 2004B or later, to monitor engine parameters, flash software, and to change power and injector trim values. Use the full dealer version purchased from a Caterpillar dealer with a yearly subscription.

6.2.4 *Crankshaft Position Sensor*—Sense the crankshaft position using a primary sensor at the crankshaft gear and a secondary sensor at the camshaft gear. The secondary sensor provides position information during cranking and in the event of a primary sensor position failure. *Calibrate the engine control software before starting the timed test operation.*

6.2.5 *Air Compressor*—*Do not use the engine-mounted air compressor for this test method.* Remove the air compressor and in its place install block-off plates, as shown in [Fig. A5.6](#). P/N 227-2574 (cover group) and P/N 223-3873 (plug group) have been found satisfactory for this purpose.

6.2.6 *Turbocharger*—Modify the turbocharger waste-gate for manual control by replacing the supplied pressure control with a manual linkage - see [Figs. A5.21-A5.23](#).

6.3 Test Stand Configuration:

6.3.1 *For Full-Load Break in*—Configure the stand with a drive-line and dynamometer capable of meeting the conditions described in the break-in and on-test subsections in section 10 of Test Method D7549.

6.3.2 *Engine Mounting*—Install the engine so that it is upright and the crankshaft is horizontal.

6.3.2.1 Configure the engine mounting hardware to minimize block distortion when the engine is fastened to the mounts. Excessive block distortion may influence test results.

6.3.3 *Intake Air System*—With the exception of the air filter and intake air tube, the intake air system is not specified. See [Fig. X1.1](#) for a typical configuration. Use a suitable air filter. Install the intake air tube ([Fig. A5.6](#)) at the intake of the turbocharger compressor. The intake air tube is a minimum 305 mm of straight, nominal 102 mm diameter tubing. The system configuration upstream of the air tube is not specified.

NOTE 3—Difficulty in achieving or maintaining intake manifold pressure or intake manifold temperature, or both, may be indicative of insufficient or excessive restriction.

6.3.4 *Charge Air Cooler*—In addition to the Caterpillar-supplied charge air cooler which is engine mounted, use another cooler to simulate the air-to-air charge air cooler used in most field applications. A Modine^{8,7} cooler (part number 1A012865) has been found suitable for this use⁹. Alternatively, other charge air coolers may be used that provide sufficient cooling capacity to control inlet manifold temperatures in the range specified elsewhere in this test method. All coolers shall be equipped with a drain system to remove condensate continuously from the boost air cooler outlet side. Remove the coolant diverter valve diaphragm for the Caterpillar supplied charge air cooler.

6.3.5 *Exhaust System*—Install the exhaust tube, see [Fig. A5.8](#), at the discharge flange of the turbocharger turbine housing. [Downstream exhaust piping is required but is left to the discretion of the laboratory to fabricate. Include a method to control exhaust back. The piping downstream of the exhaust tube is required, but not specified. Provide a method to control exhaust pressure.](#)

Comment [TB8]: Text revision to improve clarity

Comment [HA9]: this sentence appears incomplete

6.3.6 *Fuel System*—The fuel supply and filtration system is not specified. See [Fig. X1.2](#) for a typical configuration. Determine the fuel consumption rate by measuring the rate of fresh fuel flowing into the day tank. Provide a method to control fuel temperature. Return the excess fuel from the engine into the day tank.

6.3.7 *Coolant System*—The system configuration is not specified. See [Fig. X1.3](#) showing a typical configuration consisting of a non-ferrous core heat exchanger, a reservoir (expansion

⁸ The sole source of supply of this cooler known to the committee at this time is Modine Manufacturing Company. www.modine.com.

⁹ Obtain the Modine cooler from a Mack Truck dealer. Order the aftercooler using part number 5424 03 928 031. This is a non-stocked part in the Mack Parts Distribution System and appears as an invalid part number. Instruct the dealer to expedite the aftercooler on a Ship Direct purchase order. The aftercooler will be shipped directly from Modine, bypassing the normal Mack Parts Distribution System.

tank) and a temperature control valve. Pressurize the system by regulating air pressure at the top of the expansion tank. Ensure the system has a sight glass to detect air entrapment.

6.3.7.1 System volume is not specified. Avoid a very large volume as it may increase the time required for the engine coolant to reach operating temperatures.

6.3.8 *Pressurized Oil Fill System*—The oil fill system is not specified. A typical system includes an electric pump, a 50 L reservoir, and a transfer hose. [Fig. A5.24](#) shows the location of the pressurized oil fill system.

6.3.9 *External Oil System for Full-Load Break-in:*

6.3.9.1 Configure the oil system in [as shown in Fig. A6.1](#). The capacity of the oil reservoir is 10 L to 13 L. Ensure that the oil return is drawn from the bottom of the oil reservoir – see [Fig. A5.10](#). Use Viking Pump Model No. SG053514¹⁰. Locate the external oil pumps at an elevation that is below the pump supply fitting on the oil pan. The nominal oil pump motor speed is 1725 r/min. [Figs. A5.1 to A5.5](#) show the pump supply and return port locations. This system is removed for testing after the break-in and during the aeration tests. The supply and return port locations of the oil pan are capped when this system is not in use.

6.3.9.2 *Oil-Sample Valve Location*—Locate the oil sample valve on the oil sump drain port.

6.3.9.3 *Unacceptable Oil System Materials*—Do not use brass or copper fittings because they can adversely influence oil wear metal analyses in the external oil system.

6.3.10 *Crankcase Aspiration*—Vent the blowby gas at the blowby filter housing located at the left-front side of the cylinder head cover ([Fig. A5.11](#)). Use crankcase breather P/N 9Y-4357. Use breather spacer P/N 221-3934 or equivalent 20 mm thick plate with a fully open center. Use gasket P/N 9Y-1758 on each side of the spacer.

6.3.11 *Blowby Rate*—See the general configuration of this system in [Fig. A5.11](#). The minimum internal volume of the blowby canister is 26.5 L. The inside diameter of the pipe connecting the breather outlet to the blowby canister is 32 mm. Incline the pipe downward to the canister. The hose connecting the blowby canister to the flow-rate measuring device is not specified but shall match closely to the inlet of the device. The flow-rate measurement device is not specified, but must be able to measure approximately 70 L/min. The J-TEC Associates, Inc. Model No. YF563A or YF563B^{11,7} have been found to give satisfactory results under the conditions specified in this test method.

6.4 *System Time Responses*—The maximum allowable system time responses are shown in [Table 1](#). Determine system time responses in accordance with the Data Acquisition and Control

¹⁰ The sole source of supply of the apparatus known to the committee at this time is Viking Pumps, Inc., 406 State Street, Cedar Falls, IA 50613. www.vikingpump.com.

¹¹ The sole source of supply of the apparatus known to the committee at this time is J-TEC Associates, Inc., 5005 Blairs Forest Lane NE, Suite L, Cedar Rapids, IA 52402. www.j-tecassociates.co.

Automation II (DACA II) Task Force Report¹².

¹² Available from ASTM Test Monitoring Center, 6555 Penn Avenue, Pittsburgh, PA 15206-4489, Attention: Administrator.

TABLE 1 Maximum Allowable System Time Responses

Measurement	Time Response
Speed	2.0 s
Temperature	3.0 s
Pressure	3.0 s
Fuel Flow	40.0 s
Oil Sample Flow	<u>4.0</u> s

6.5 *Oil Sample Containers*—Preferably use high-density polyethylene containers for oil samples. (**Warning**—Avoid using glass containers which may break and cause injury or exposure to hazardous materials.)

7. Engine Liquids and Cleaning Solvent

7.1 *Test Oil*—Approximately 115 L of test oil is required to complete the test.

7.2 *Test Fuel*—Approximately 490 L of Chevron Philips PC-10 ultra-low-sulfur diesel fuel¹³ is required to complete the test.

7.3 *Engine Coolant:*

7.3.1 Use a mixture of equal parts by volume of mineral-free water and Caterpillar-brand, coolant concentrate P/N ~~119-5150~~^{6,7}.

7.3.2 As an option, premixed coolant is available and may be used directly.

7.3.2.1 **Table 2** shows Caterpillar part numbers for several sized containers of concentrate and premixed coolant.

7.3.3 The mineral-free water shall have a mineral content not exceeding 34.4 mg/kg of total dissolved solids.

7.3.4 Replace the coolant mixture after 5000 h. The mixture shall remain at equal parts by volume of water and concentrate during the course of the test. Keep the coolant mixture free from contamination.

7.3.5 Keep the total solids below 5000 mg/kg.

7.3.6 Maintain a correct additive concentration.

7.4 *Cleaning Solvent*—Use a solvent meeting the requirements of Specification D235, Type II, Class C for volume fraction aromatics 0 % to 2 % , flash point (61 °C, min), and color (not darker than +25 Saybolt or 25 Pt-Co). Obtain a certificate of analysis for each batch of solvent from the supplier. (**Warning**—Combustible. Health Hazard. Use adequate safety precautions.)

Comment [J10]: Special build RTV is likely going to be recommended.
Terry Bates: Sean to revert to TF and advise.

Comment [HA11]: If an RTV is to be used, it should be Si-free. One product that we recommend is Loctite 5810A sealant, part number 39211

Comment [TB12]: Form 11 of the Data Dictionary has specs for the fuel. We do not have fuel specs here. Should they be included in an Annex?

Comment [HA13]:

Comment [HA14]: Replace with 238-6847

Comment [HA15]: How is this determined? What is the history of this requirement?

Comment [HA16]: This coolant lasts 12000 hours with ELC extender added at 6000 hours. I recommend that we extend this replacement period.

Comment [HA17]: Would like to know the history and how is this determined.

¹³ The sole source of supply of the fuel known to the committee at this time is Chevron Philips Chevron Phillips Chemical Company LP, 10001 Six Pines Drive, Suite 4036B, The Woodlands, TX 77387-4910, www.cpchem.com.

TABLE 2 Part Numbers for Cat^A ELC^B Coolant Concentrate and Premixes

Container Size	3.8 L	19 L	208 L	Tote, ^C 275 g
Concentrate P/N	238-8647
Premix ^D P/N	238-8648	238-8649	238-8650	361-1024

Comment [HA18]: I changed all the part numbers in this table. The old numbers are not valid anymore.

^A Registered Trademark of Caterpillar Inc., 100 North East Adams St., Peoria, IL 61629.

^B Trademark of Caterpillar Inc., 100 North East Adams St., Peoria, IL 61629.

^C A small container.

^D Equal parts by volume of mineral-free water and coolant concentrate.

8. Preparation of Apparatus

8.1 *Cleaning of Parts:*

8.1.1 *General*—Preparation of test engine components specific to the Caterpillar C13 test are indicated in this section. Use the Caterpillar Service Manual Form SEN R 9700¹⁴ for the preparation of other components (except for the piston second ring—see 8.2.7). Take precautions to protect rusting of iron components. Use of an engine parts washer followed by a solvent wash is permitted.

Comment [HA19]: Shouldn't this be "protect iron components from rusting"?

8.1.2 *Engine Block*—Disassemble the engine, including removal of the crankshaft, camshaft, piston cooling tubes, oil pump, and oil gallery plugs. Thoroughly clean the surfaces and oil passages (galleries). Use a nylon brush to clean the oil passages. Removal of camshaft bearings is optional.

8.1.3 *Cylinder Head, Intake System and Duct*—Disassemble and clean these components before each test. Scrub with a nylon brush and solvent. Use of an engine parts washer followed by a solvent wash is permitted.

8.1.4 *Rocker Cover and Oil Pan*—Clean the rocker cover and oil pan. Use a nylon brush, as necessary, to remove deposits.

8.1.5 *External Oil System*—Flush the internal surfaces of the oil lines and the external reservoir with solvent. Repeat until the solvent drains cleanly. Flush the solvent through the oil pumps until the solvent drains cleanly, then air dry.

8.1.6 *High Pressure Turbocharger*—Carefully remove the turbine housing from the turbocharger and clean the waste-gate valve with solvent and a soft, wire brush.

8.1.7 *Cam Follower Assembly*—Take the cam follower assembly apart and inspect the bushings and pins. Replace the parts as necessary.

¹⁴ Available from a Caterpillar parts distributor.

8.2 Engine Assembly:

8.2.1 General:

8.2.1.1 Perform an engine assembly at the laboratory's discretion. Instances when an engine rebuild should be considered include not meeting operational conditions, or when reference limits cannot be met.

8.2.1.2 Except as noted in this section, use the procedures described in the Caterpillar Service Manual Form SEN R 9700¹⁴. Assemble the engine with the components shown in the Engine Build Parts List ([Annex A3](#)).

8.2.2 *Parts Reuse and Replacement*—Reuse engine components, except as noted in [8.2.7](#), and provided that they meet production tolerances as described in the Caterpillar Service Manual.

8.2.3 *Build-up Oils*—For the head, main caps, and rod bolts, use CAT DEO-ULS engine oil¹⁴ as the build-up oil. If test oil is used, the engine build is valid only for the respective test oil.

8.2.4 *Coolant Thermostat*—Lock the engine-coolant thermostat open.

8.2.5 *Fuel Injectors*—Use P/N 239-4908 fuel injectors. If fuel injectors are reused, exercise caution to avoid mechanical damage to or contamination of the nozzles. Dedicate the injectors to a particular cylinder. Install the injectors according to the method described in Caterpillar Service Manual Form SENR9700¹⁴. Use Mobil EF-411^{15,7} engine oil as the build-up oil for the injector o-rings.

8.2.6 *Piston Cooling Tubes*—[Aim the piston cooling tubes at the underside of the pistons according to the specifications on the TMC website](#). Contact the TMC for details

8.2.7 *New Parts*—The following new parts are included in the Engine Build Parts List. They are not reusable. Clean the parts prior to use. A full rebuild parts list is available from the TMC². For piston second rings, follow the [D7549](#) Piston Second Ring Pre-Test Cleaning Procedure, available from the TMC. During a test, a replacement of any of the new parts listed below will invalidate the test:

8.2.7.1 Pistons.

8.2.7.2 Piston rings (top, second and oil).

8.2.7.3 Cylinder liners.

8.2.7.4 Valves (intake, exhaust).

8.2.7.5 Valve guides.

8.2.7.6 Valve seats.

8.2.7.7 Connecting rod bearings, main bearings and thrust plate.

8.2.7.8 Turbochargers

8.2.7.9 Oil pump

8.2.7.10 Oil pressure regulator springs located inside of the oil filter block.

¹⁵ The sole source of this oil known to the committee at this time is Exxon-Mobil Oil Corp., P.O. Box 66940, AMF O'Hare, IL 60666, Attention Illinois Order Board.

8.3 *Operational Measurements:*

8.3.1 *Specified Units and Formats*—See [Annex A8](#).

8.3.2.1 *Fuel Consumption Rate Measurement*—Calibrate the fuel consumption rate measurement system before each reference oil test sequence and within six months after completion of the last successful calibration test. Temperature-compensate volumetric systems, and calibrate them against a standard mass flow device. The flowmeter on the test stand shall agree within 0.2 % of the calibration standard, that standard itself being calibrated against a national standard.

8.3.2.2 *Temperature-Measurement Calibration*—Calibrate the temperature measurement systems before each reference oil test sequence and within six months after completion of the last successful calibration test. Each temperature measurement system shall agree within ± 0.5 °C of the laboratory calibration standard, that standard itself being calibrated against a national standard.

8.3.2.3 *Pressure-Measurement Calibration*—Calibrate the pressure measurement systems before each reference oil test sequence and within six months after completion of the last successful calibration test. Confirm the calibration standard against a national standard.

8.3.2.4 *FDM Calibration:*

(a) The FDM shall only be calibrated by a certified third party according to the manufacturer's suggestion using a specified fluid and precision.

(b) Calibrate the FDM with each engine rebuild or if there are concerns with the accuracy of the density or flow measurements.

(c) Check the flow rate calibration using the method described in 8.3.2.1. Verify the density measurement for relative accuracy by filling the FDM with a fluid of known density.

8.3.3 *Temperature-Measurement Locations:*

8.3.3.1 *General*—The measurement equipment is not specified. Install the sensors such that the tip is located midstream of the flow unless otherwise indicated. The accuracy and measurement of the temperature measurement sensors and the complete measurement system shall follow the guidelines in ASTM Research Report RR:D02-1218¹².

8.3.3.2 *Coolant-Out Temperature*—Install the sensor in the fitting on the thermostat housing ([Fig. A5.13](#)).

8.3.3.3 *Coolant-In Temperature*—Install the sensor on the right side of the coolant pump intake housing at the 1-in. NPT port ([Fig. A5.14](#)).

8.3.3.4 *Fuel-In Temperature*—Install the sensor in the fuel pump inlet fitting ([Fig. A5.16](#)).

8.3.3.5 *Oil-Gallery Temperature*—Install a ~~1/8 in.~~ 3.175 thermocouple at the sensor at the 3/8 in. NPT female boss on the right-rear of the engine ([Fig. A5.15](#)) extending from the cross fitting described in [Table A6.1](#) to the center of the oil gallery flow.

8.3.3.6 *Intake-Air Temperature*—Install the sensor in the inlet air tube 127 mm upstream of the compressor connection ([Fig. A5.7](#)).

8.3.3.7 *Intake-Manifold Temperature*—Install the sensor at the 1/8 in. NPT female boss on the outside radius of the inlet manifold elbow ([Fig. A5.17](#)).

Comment [TB20]: Insufficient information for a yesy method user to know how to contact a certified third party user. **TF to provide more info.**

Comment [TB21]: Have replaced "1/8 in." by "3.175 mm". Is this OK?

8.3.3.8 *Exhaust Temperature*—Install the sensor in the exhaust tube ([Fig. A5.8](#)).

8.3.3.9 *Aeration-System-Enclosure Temperature*—Insert the sensor 75 mm directly above the vertical centerline of the micro motion and extending into the enclosure to the vertical plane of the FDM face.

8.3.3.10 *Oil-sump Temperature*—Insert a thermocouple to a depth of 50 mm into the drain plug port on the right front pan pictured in [Fig A5.6](#).

8.3.3.11 *Additional Temperatures*—It is permissible to measure any additional temperatures that may be useful for test operation or engine diagnostics.

NOTE 4—Additional exhaust sensor locations, at the exhaust ports and pre-turbine (front and rear), are recommended. The detection of changes in exhaust temperatures is an important diagnostic feature.

8.3.4 *Pressure-Measurement Locations:*

8.3.4.1 *General*—The measurement equipment is not specified. Follow the guidelines in ASTM Research Report RR:D02-1218¹² for the accuracy and resolution of the pressure measurement sensors and the complete measurement system. If the laboratory has problems with condensation forming in the pressure lines, install a condensation trap at the lowest elevation of the tubing between the pressure measurement location and the final pressure sensor for crankcase pressure, intake air pressure, and exhaust pressure. Route the tubing to avoid intermediate loops or low spots before and after the condensation trap.

8.3.4.2 *Oil-Gallery Pressure*—Measure the pressure at the $\frac{1}{4}$ in. NPT fitting on the right rear of the engine ([Fig. A5.15](#)).

8.3.4.3 *Oil-Filter-Inlet Pressure*—Measure the pressure at the plug located on the inlet side of the oil filter assembly ([Fig. A5.9](#)).

8.3.4.4 *Inlet-Manifold Pressure*—Measure the pressure at the $\frac{1}{4}$ in. NPT port on the outside radius of the inlet manifold elbow ([Fig. A5.17](#)).

8.3.4.5 *Crankcase Pressure*—Measure the pressure by installing a bulkhead fitting in the valve cover, top-front ([Fig. A5.12](#)).

8.3.4.6 *Intake-Air Pressure*—Measure the pressure at a wall tap on the intake air tube 153 mm upstream of the compressor connection ([Fig. A5.7](#)).

8.3.4.7 *Exhaust Pressure*—Measure the pressure on the exhaust tube ([Fig. A5.8](#)).

8.3.4.8 *Fuel Pressure*—Measure the pressure at the fuel filter head ([Fig. A5.25](#)).

8.3.4.9 *Coolant Pressure*—Measure the pressure on top of the expansion tank ([Fig. X1.3](#)).

8.3.4.10 *Intercooler Delta Pressure*—Measure the pressure drop across the intercooler. Measure the intercooler inlet pressure at the elbow outlet of the CAT charge air cooler ([Fig. A5.19](#)). Use the intake manifold pressure ([8.3.4.4](#)) as the intercooler outlet pressure. The intercooler delta pressure is the difference between the intercooler outlet pressure and the intercooler inlet pressure.

8.3.4.11 *Additional Pressures*—It is permissible to measure any additional pressures that may be useful for test operation or engine diagnostics.

NOTE 5—See [Fig. A5.19](#) and [Fig. A5.20](#) for additional instrument placement information.

8.3.5 Flow-Rate-Measurement Locations:

8.3.5.1 *General*—The equipment for fuel-rate measurements is not specified. Follow the guidelines in ASTM Research Report RR:D02-1218¹² for the accuracy and resolution of the flow-rate-measurement system.

8.3.5.2 *Blowby*—Measure the blowby flow rate using a JTEC model VF563A or VF563B. See 6.3.11 for blowby measurement system configuration.

8.3.5.3 *Fuel Flow*—Determine the fuel consumption rate by measuring the fuel flowing to the day tank (Fig. X1.2).

8.3.6 *Controller outputs and indications of malfunction in the aeration measurement system*—Record the controller output as % for the sample pressure control regulator. If this value is above 50 % for 15W-40 or thinner viscosity oils (that is, for oils with kinematic viscosity at 100 °C less than 12.5 mm²/s) the test is invalid. Oils of higher-thicker viscosity need a statement of validity in the comments section of the report if the controller output exceeds 50 %.

Comment [HA22]: The word thinner can be substituted with "lower". (ex 10W-30) Similarly the word thicker can be substituted with "higher"

Comment [TB23]: We need to clarify what is meant by "thinner than 15W-40" . Please confirm this is correct

8.3.7 *Parameters for Aerated Oil Samples*—Measure temperature, pressure, flow rate, and density using the aeration system shown in Fig. A3.1.

8.3.7.1 Record the oil sample temperature as the average of the inlet and outlet thermocouple temperatures of the FDM. (This temperature is a theoretical temperature at the midpoint of the FDM.)

8.3.7.2 Record the oil sample pressure as the average of the inlet and outlet pressure transducers of the FDM. (This temperature is a theoretical pressure at the midpoint of the FDM.)

9. Engine/Stand Calibration and Non-Reference Oil Tests

9.1 Annex A9 describes calibration procedures using the TMC reference oils, including their storage and conditions of use, the conducting of tests, and the reporting of results."

9.2 Annex A10 describes maintenance activities involving TMC reference oils, including special reference oil tests, special use of the reference oil calibration system, donated reference oil test programs, introducing new reference oils, and TMC information letters and memoranda."

9.3 Annex A11 provides information regarding new laboratories, the role of the TMC regarding precision data, and the calibration of test stands used for non-standard tests."

9.4 Stand Calibration:

9.4.1 Calibrate the test stand by conducting a test with a blind reference oil (see A9.2). Submit the results to the TMC as described in A9.6. Determine reference oil test acceptance according to LTMS.

9.4.2 *New Test Stand*—A new test stand is one that has never been calibrated or has not completed an acceptable reference oil test within 24 months of the end of test (EOT) date of the last acceptable reference oil test. Perform a calibration as described in 9.4.1 to introduce a new test stand.

9.4.3 *Stand Calibration Period*—The calibration period is 6 months and a certain number of operationally valid non-reference oil tests, whichever comes first, from the EOT date of the last

acceptable reference oil test. The number of non-reference oil tests allowed during a calibration period is determined by the number of reference oil tests that have been completed on a test stand. The first calibration period on a new stand is 6 months or 2 non-reference oil tests whichever comes first. The second calibration period on a stand is 6 months or 4 non-reference oil tests. The 3rd calibration period on a stand is 6 months or 6 tests. The 4th and all subsequent calibration periods on a test stand is 6 months or 9 tests.

9.4.4 Stand Modification and Calibration Status—Stand calibration status will be invalidated by conducting any non-standard test or modification of the test and control systems, or both. A non-standard test is any test conducted under a modified procedure, or using non-procedural hardware, or using controller set point modifications, or any combination thereof. If changes are made the current calibration period is terminated. A reference test is required before restarting the current calibration period (see [A9.2.2](#)). If changes are contemplated, contact the TMC beforehand to ascertain the effect on the calibration status.

9.5 Test Numbering System:

9.5.1 The test number for both reference and non-reference oils has three parts: X, Y and Z where X represents the test stand number, Y the sequential test stand run number and Z the number of hours run on the stand since the last reference oil test. For example 27-15-150 indicates test stand number 27 and test stand run number 15 that has been run for 150 hours since the last reference oil test. The test stand run number, Y will increase sequentially by one for each test start (reference oil or non-reference oil). A letter suffix may also be necessary (see [9.5.2](#)).

9.5.2 A reference oil test conducted subsequent to an unacceptable reference oil test shall include a letter suffix after Y. The letter suffix shall begin with A and incremented alphabetically until acceptable reference oil test is completed. For example, if two consecutive unacceptable reference oil tests were conducted and the first number was 27-15-150, the second test number would be 27-16A-150. A third calibration attempt would have the test number 27-17B-150. If the third test were acceptable, then 27-17B-150 would identify the reference oil test in the test report.

9.5.3 Non-Reference Oil Tests—Add no letter suffix to Y for aborted or operationally invalid non-reference oil tests.

9.6 Reference Oil Tests—Carry out reference oil tests as described in A9.5 and report the results to the TMC as described in A9.6. Determine reference oil test acceptance [according to LTMS](#).

9.7 Non-Reference Oil Tests: Last Start Date—when running non-reference oil test during the calibration period; crank the engine prior to the expiration of the calibration period ([9.4.3](#)).

10. Procedure

10.1 Engine Break-in:

10.1.1 Following the engine assembly, install the engine on the stand and connect the engine to the stand support system.

10.1.2 Carry out [the engine](#) break-in as described in Annex A12.

10.1.2.1 Shutdown During Break-in—If a shutdown occurs during the break-in, resume the break-in from the point at which the shutdown occurred. Record such an occurrence in Other

Comments on the appropriate report form.

NOTE 6—Use the break-in as an opportunity to confirm engine performance and to make repairs prior to the start of the 50 h test procedure.

10.1.3 After completion of the engine break-in, shut the engine down, using the normal shutdown procedure described in 10.3.1.

10.1.4 Drain the oil and remove the oil filter.

NOTE 7—After the engine has performed the break-in it can be transferred to the stand equipped with the aeration measurement system and instrumented according to this procedure. Alternatively, both the break-in and the aeration testing can be carried out on the same stand provided as it can meet the break-in procedure conditions and can also maintain the operation conditions defined in this procedure for aeration testing.

10.2 *Pretest Procedure:*

10.2.1 Install a new Caterpillar IR-1808 oil filter¹⁴.

10.2.2 Charge the engine with 32.2 L \pm 0.2 L of test oil.

10.2.2.1 Use the pressurized, oil-fill system described in 6.3.8 or charge manually through the engine-oil, add-tube.

10.2.3 *Warm-up*—Start the engine and perform the warm-up described by Steps 1 and 2 of Table 3. After completion of Step 2, perform a 2 min cool-down at Step 1 conditions before shutting down the engine.

10.2.4 Drain the engine of the initial oil charge while allowing the oil sampling circuit pump to run and drain.

10.2.5 [Repeat 10.2.2 to 10.2.4.](#)

10.2.6 Measure out 36 L \pm 0.2 L of test oil and determine the mass. Record the volume and mass of the oil. Charge the engine as described in 10.2.2.1.

10.3 *Shutdowns and Maintenance*—The test may be shutdown at the discretion of the laboratory to perform repairs. However, the intent of this test method is to conduct the 50 h test procedure without shutdowns. Shutdowns between 30 h and 50 h test time invalidate the test. This period is critical for accurate measurement of the aeration average from 40 h to 50 h.

10.3.1 *Normal Shutdown*—A normal shutdown is accomplished by ramping down to warm-up Step 1 conditions (Table 3), running for 2 min, and then stopping the engine.

10.3.2 *Emergency Shutdown*—An emergency shutdown occurs when the normal shutdown cannot be completed, such as under an alarm condition. During an emergency shutdown ignition can be turned off immediately and the engine allowed to stop. Such an occurrence is described in “Other Comments” of the appropriate report form (see 12.1).

10.3.3 *Maintenance*—Engine components or stand support equipment or both may be repaired or replaced at the discretion of the laboratory and in accordance with this method. It is recommended to monitor the condition of the oil pressure regulator springs within the oil filter housing. These springs may require replacement if the oil gallery pressures are not typical.

10.3.4 *Downtime*—The limit for total downtime is not specified. Record on the appropriate report form all shutdowns, pertinent actions and total downtime during the 50 h test procedure. Downtime is calculated as the period between the engine leaving on-test and until it returns to

on-test. Warm-up periods are included in the downtime period.

10.3.5 *Engine Restarting*—Each time the engine is re-started, perform the warm-up described in 10.2.3 before proceeding onto test.

TABLE 3 Warm-up Conditions

Parameter, units	Step 1	Step 2
Stage Length, min	5	30
Speed, r/min	900	1800
Load, N•m	0	0
Coolant Out Temperature ^A , ° C	90	90
Intake Air Temperature ^A , ° C	25	25
Manifold Temperature ^A , ° C	40	40
Fuel Temperature ^A , ° C	40	40
Gallery Oil Temperature ^A , ° C	90	90
Sample Oil Temperature ^A , ° C	90	90
Sample Oil Flow ^A , L/min	1.5	1.5
Sample Oil Pressure ^A , kPa (absolute)	150	150
Intake Air Pressure ^A , kPa (absolute)	96	96
Fuel Flow Rate, g/min	Record	Record
Blowby Flow Rate, L/min	Record	Record
Intake Manifold Pressure ^B , kPa (gage)	Record	Record
Exhaust After Turbo Temperature ^A , ° C	Record	Record
Fuel Pressure, kPa (gage)	Record	Record
Oil Gallery Pressure, kPa (gage)	Record	Record
Coolant System Pressure, kPa (gage)	100	100
Exhaust Restriction Pressure, kPa (absolute)	104	104
Crankcase Pressure, kPa (absolute)	103	103
Aeration Enclosure Temperature, ° C	50	50

^A This is the control set-point. It can require up to 30 min of operation to achieve.

^B With turbocharger waste-gate fully closed.

10.4 Determination of Baseline Densities:

10.4.1 General—The percent aeration of the test oil is based on a comparison of the densities of the fresh, un-aerated oil and the aerated oil sampled during the engine operation (see Table 5). To ensure the results are not vitiated by the effects of temperature, all densities are calculated at a reference temperature of 90 °C. For this purpose, the temperature dependence of the density of the un-aerated fresh oil is determined by Test Method D4052 and is used to calculate, from density temperature regressions, the density at 90 °C of the both the un-aerated fresh oil and the

Comment [TB24]: Sections 10.4 and 10.5 have been extensively rewritten. The TF is requested to endorse the current text or to revise as appropriate.

Comment [HA25]: Can you please use a different word – “vitate” is very uncommon. Options are “impair” or so simply state: “to eliminate the effects of temperature on the density results, all...”

aerated sample oil. The D4052 density of the un-aerated fresh oil and its temperature dependence are referred to as baseline values and are determined after completion of the pretest procedure described in 10.2 and before carrying out the 50 h test procedure described in 10.6. The baseline data are also used to check the accuracy of the FDM-determined densities.

10.4.2 Baseline D4052 Density and its Temperature Dependence:

10.4.2 Measure the density of the fresh test oil between 30 °C to 90 °C at 10 °C increments using Test Method D4052.

10.4.3 Use these seven data points to calculate the first order, linear regression of density versus temperature using the least squares method. R^2 values shall be greater than 0.99990. Repeat the density measurements as necessary until the required value is obtained.

10.4.4 The slope of this line quantifies the effect of temperature on the D4052 density of the fresh, un-aerated oil and is denoted by $\frac{d}{dT}\rho_{BL}$; the intercept at 90 °C is the D4052 density of the un-aerated fresh oil at 90 °C and is denoted by ρ_{BL} . (Here ρ and T are used as the symbols for density and temperature, respectively, and BL denotes “baseline”.)

10.5 Checks to Determine if the FDM Needs Recalibration:

10.5.1 General—Before initiating the 50 h test it is necessary to check if the FDM calibration carried out in 8.3.2.4 is still valid. This check is carried out by comparing the D4052 baseline density of the fresh oil at 90 °C, ρ_{BL} , and its temperature sensitivity, $\frac{d}{dT}\rho_{BL}$, with the corresponding FDM values for the un-aerated oil sampled during warm-up operation. Using criteria described in Annex A13, the magnitude of the difference between the FDM and D4052 densities is used to determine the need to recalibrate the FDM.

10.5.2 After 10.2.5, start the engine and perform the 30 min warm-up described in Table 3.

10.5.2.1 Record the oil sample density, as measured by the FDM, and its corresponding temperature for all data points between 80 °C and 90 °C as the engine is warming up. This temperature window is typically seen during the last 10 min of warm-up Step 2. This data allows calculation of the temperature dependence of the FDM density of the unaerated oil.

10.5.2.2 Immediately following the end of step 2, run the engine for 5 min under Step 2 warm-up conditions to provide data for calculating the FDM-density at 90 °C. All controlled parameters defined in the Table 3 shall be within limits and stable. Record the oil sample density and its corresponding temperature during this 5 min period.

10.5.3. Temperature Dependence of the FDM Density of the Un-aerated Oil—Use the data generated in 10.5.2.1 to calculate the first order, linear regression of FDM-determined density versus FDM temperature using the least squares method.

10.5.3.1 The slope of this linear regression quantifies the effect of temperature on the FDM density of the un-aerated oil for the temperature range 80 °C to 90 °C. This slope is denoted by $\frac{d}{dT}\rho_{FDM}$.

10.5.3.4 Do not use $\frac{d}{dT}\rho_{FDM}$ in the calculation of oil aeration in Table 5.

10.5.4 FDM Density at 90 °C of the Un-aerated Oil:

Comment [TB26]: Have made it mandatory.

Do we need to define “stable”?

Comment [sam27]: This is ongoing

10.5.4.1 Use the temperature data generated in 10.5.2.2 to calculate the average inlet and outlet thermocouple temperatures during the 5 min period. This temperature is a theoretical temperature at the midpoint of the FDM. It is denoted here by T_{WARMUP} .

10.5.4.2 Calculate the average FDM density from the data generated in 10.5.2.2. This is the FDM density of the un-aerated oil at the warm-up temperature and is denoted by ρ_{WARMUP} .

10.5.4.4 Do not use ρ_{WARMUP} in the calculation of oil aeration in Table 5.

10.5.4.5 Correct ρ_{WARMUP} for any deviation of the sample temperature, T_{WARMUP} , from 90 °C, using the following relationship:

$$\rho_{\text{FDM}} = \rho_{\text{WARMUP}} + (90 - T_{\text{WARMUP}}) \times \frac{d}{dT} \rho_{\text{D4052}} \quad (1)$$

where:

ρ_{FDM} is the calculated FDM density of the unaerated oil at 90 °C.

10.5.5 Compare base line and FDM-densities and their temperature dependencies:

10.5.5.1 Compare ρ_{BL} with ρ_{FDM} and $\frac{d}{dT} \rho_{\text{BL}}$ with $\frac{d}{dT} \rho_{\text{FDM}}$. Use Annex A13 to interpret the results to determine if the FDM needs to be recalibrated. Support modifications to this coefficient calculation or data set with comments if the test laboratory calculates this value in any other manner.

Comment [TB28]: Annex A13 is currently blank. Please provide the necessary info.

Comment [sam29]: This is an ongoing discussion. Keep this comment open.

Comment [sam30]: Again waiting on a decision from the task force

10.6 50 h Test Procedure:

10.6.1 Immediately after completing the warmup and baseline reference procedure described in 10.4 and without shutting down the engine, start the 50 h test procedure described in Table 4.

10.6.3 *Test Timer*—The 50 h test timer starts immediately following the warmup and baseline reference described in 10.4. If a shutdown occurs, stop the test timer immediately at the initiation of the shutdown. The test timer shall resume after the warm-up described in Table 3 and when the test has been returned to the test operation schedule and all controlled parameters are within specification requirements.

10.6.4 *Operational Data Acquisition*—Record all operational parameters shown in Table 4 with automated data acquisition at a minimum frequency of once every 30 s. Recorded values shall have a minimum resolution in accordance with Annex A8.

10.6.4.1 Record the operational data on the appropriate test report form.

10.6.5 *Oil Sampling and Analyses:*

10.6.5.1 *New Oil Sample*—Take a 240 mL sample of the fresh test oil from the original oil container. Measure and report the parameters shown A14.2.

10.6.5.2 Take oil samples and carry out analyses according to the schedule and methods shown in Annex A14.

10.6.5.3 Record the results on the appropriate test report form.

10.6.6 *Parameters for Aerated Oil Samples*—Measure the sample oil temperature, pressure, flow rate, and FDM density using the aeration system shown in Fig. A7.1.

10.6.6.1 Record the oil sample temperature as the average of the inlet and outlet thermocouple

temperatures of the FDM. (This temperature is a theoretical temperature at the midpoint of the FDM.)

10.6.6.2 Record the oil sample pressure as the average of the inlet and outlet pressure transducers of the FDM. (This pressure is a theoretical pressure at the midpoint of the FDM.)

10.6.7 After completion of the 50 h test perform a normal shutdown as described in 10.3.1.

10.6.8 Drain the test oil charge from the engine with the oil sample circuit pump running, weigh the drained oil and calculate the total oil consumed during the test as the difference in mass between the initial charge (as recorded in 10.2.5) and the drained oil.

TABLE 4 Schedule of Conditions for the 50 h Test

Parameter, unit	Step 1
Stage Length, h	50
Speed, r/min	1800
Load, N•m	0
Coolant Out Temperature, ° C	90
Air Intake Temperature, ° C	25
Intake Manifold Temperature, ° C	40
Fuel-in Temperature, ° C	40
Oil Gallery Temperature, ° C	90
Sample Oil Temperature ^A , ° C	90
Sample Oil Flow Rate ^A , L/min	1.5
Sample Oil Pressure ^A , kPa (absolute),	84
Intake Air Pressure, kPa (absolute),	96 ± 1.5
Fuel Flow Rate, g/min	Record
Blowby Flow Rate, L/min	Record
Intake Manifold Pressure ^B , kPa (gage)	Record
Crankcase Pressure, kPa (gage)	103
Intercooler Delta Pressure, kPa (gage)	15 max.
Exhaust After Turbo Temperature, ° C	Record
Fuel Pressure, kPa (gage)	Record
Oil Gallery Pressure, kPa (gage)	Record
Coolant System Pressure, kPa (gage)	100 99 to 107
Exhaust Restriction Pressure, kPa (absolute)	104
Pressure Regulator Controller Output ^{C,D} , %	<50_ %
Micropump Controller Output ^{C,D} , %	<50_ %

^A Micro Motion parameter

^B With turbocharger waste-gate fully closed.

^C If this value is above 50 % output for 15W-40 or thinner viscosity oils the test is invalid. Oils of higher viscosity need a statement of validity in the comments section of the report if they exceed 50 % output.

^D Average value over the length of the test.

11. Calculation, Test Validity and Test Results

11.1 *Oil Aeration Calculations*—Calculate the oil aeration from the data acquired in 10.6.6 using the relations described in **Table 5**. Report on the appropriate test report form. Report the aeration percentage to two decimal places.

Table 5 Parameters and equations used for calculating oil aeration

Parameter, unit	Symbol	Definition
<u>Sample oil density, kg/m³</u>	ρ_{SAMPLE}	<u>FDM density of the aerated oil at the sample oil temperature, T_{SAMPLE}</u>
<u>Sample oil temperature, °C</u>	T_{SAMPLE}	<u>Average of the FDM inlet and outlet temperatures</u>
<u>Sample oil pressure, kPa (absolute)</u>	P_{SAMPLE}	<u>Average of the FDM inlet and outlet pressures</u>
<u>Air density^{A,B}, kg/m³</u>	ρ_{AIR}	<u>(Sample Oil Pressure) [287.003(Sample Oil Temp. + 273.15)]</u>
<u>Baseline oil density kg/m³,</u>	ρ_{BL}	<u>The calculated D4052 density of the fresh, un-aerated oil at 90 °C (see 10.4.4)</u>
<u>Temp. dependence of baseline oil density, kg/(m³ °C)</u>	$\frac{d}{dT}\rho_{\text{BL}}$	<u>The calculated dependence of the baseline oil density on temperature (10.4.4)</u>
<u>Temperature corrected density^C, kg/m³</u>	$\rho_{\text{SAMPLE } 90}$	<u>The calculated sample density at 90 °C</u>
<u>Oil aeration^D, %</u>	OA	<u>$\frac{100(\text{Baseline oil density})}{(\text{Temp. corrected density} - \text{Air density})}$</u>

Comment [TB31]: This Table has been extensively revised. The TF is requested to endorse it or to revise as appropriate.

^A In the definition, 273.15 is the ice point in °C and 287.003 is the specific gas constant for dry air with units $\text{J kg}^{-1} \text{K}^{-1}$, where K is the symbol for kelvin.

^B In symbols: $\rho_{\text{AIR}} = P_{\text{SAMPLE}} / [287.003 \times (T_{\text{SAMPLE}} + 273.15)]$.

^C This is the calculated oil sample density at 90 °C and is denoted by $\rho_{\text{SAMPLE } 90}$. It is the sample oil density, ρ_{SAMPLE} , corrected for the deviation of the oil sample temperature, T_{SAMPLE} , from 90 °C. The correction uses the temperature dependence of the baseline oil density, $\frac{d}{dT}\rho_{\text{BL}}$, established in 10.4.4.

^D In symbols: $OA = 100\rho_{\text{BL}} / (\rho_{\text{SAMPLE } 90} - \rho_{\text{AIR}})$.

11.1.1 Do not include any values obtained within a 4 h period following an engine shutdown and restart in the calculation of oil aeration averages.

11.2 Test Results:

11.2.1 Report the average aeration value for the operational period 40 h to 50 h.

11.2.2 Calculate the first order linear regression of oil aeration versus time for the test period

from 40 h to 50 h using the least squares method

11.2.3 Report these results on the appropriate form of the test report.

11.3 *Assessment of Operational Validity:*

11.3.1 *Controller outputs and indications of malfunction in the aeration measurement system*—Record the controller output percentage for the sample pressure control regulator. If this value is above 50 % output for ~~15W-40 or thinner viscosity oil~~ oil viscosities thinner than XW-40 the test is invalid. Oils of with viscosities thicker than XW-40 need a statement of validity in the comments section of the appropriate report form if they exceed 50 % output.

Comment [TB32]: 15W-40 or thinner is vague. Suggest wording shown. Please confirm it is correct.

11.3.2 Calculate and report the quality index as described in A15.1.

11.3.3 Calculate and report averages as described in A15.2.

11.3.4 Determine operational validity as described in A15.3.

11.3.5 Perform an engineering review and report the results as described in A15.4.

12. Report

12.1 For reference oil results, use the standardized report form set available from the ASTM TMC and data dictionary for reporting test results and for summarizing operational data.

NOTE 8—Report the non-reference oil test results on these same forms if the results are intended to be submitted as candidate oil results against a specification.

12.1.1 Fill out the report forms according to the formats shown in the data dictionary.

12.1.2 Transmit results to the TMC within 5 working days of test completion.

12.1.3 Transmit the results electronically as described in the ASTM Data Communications Committee Test Report Transmission Model (Section 2—Flat File Transmission Format) available from the ASTM TMC. Upload files via the TMC's website.

12.2 Report all reference oil test results, whether aborted, invalidated, or successfully completed, to the TMC.

12.3 *Deviations from Test Operational Limits*—Report all deviations from specified test operational limits.

12.4 *Precision of Reported Units*—Use the Practice E29 rounding-off method for critical pass/fail test result data. Report the data to the same precision as indicated in data dictionary.

12.5 In the space provided, note the time, date, test hour, and duration of any shutdown or off-test condition. Document the outcome of all prior reference oil tests from the current calibration sequence that were operationally or statistically invalid.

12.6 If a calibration period is extended beyond the normal calibration period length, make a note in the comment section and attach a written confirmation of the granted extension from the TMC to the test report. List the outcomes of previous runs that may need to be considered as part of the extension in the comment section.

13. Precision and Bias

13.1 Precision:

13.1.1 Test precision is established on the basis of operationally valid reference oil test results monitored by the TMC.

13.1.2 *Intermediate Precision Conditions*—Conditions where test results are obtained with the same test method using the same test oil, with changing conditions such as operators, measuring equipment, test stands, test engines, and time.

NOTE 9—Intermediate Precision is the appropriate term for this test method, rather than repeatability, which defines more rigorous within laboratory conditions.

13.1.2.1 *Intermediate Precision Limit (i.p.)*—The difference between two results obtained under intermediate precision conditions that in the long run, in the normal and correct conduct of the test method, exceed the value shown in Table 6 in only one case in twenty.

13.1.3 *Reproducibility Conditions*—Conditions where test results are obtained with the same test method using the same test oil in different laboratories with different operators using different equipment.

13.1.3.1 *Reproducibility Limit (R)*—The difference between two results obtained under reproducibility conditions that would, in the long run, in the normal and correct conduct of the test method, exceed the values in Table 6 in only one case in twenty.

13.1.4 The test precision for [the COAT](#) as of June 12, 2015 is shown in Table 6. [The TMC updates precision data frequently, and this information can be obtained by contacting the TMC.](#)

13.2 *Bias*—Bias is determined by applying an accepted statistical technique to reference oil test results and, when a significant bias is determined, a severity adjustment is permitted for non-reference oil test results (refer to the TMC for details).

Comment [HA33]: This sentence seems incomplete: rigorous what?

TABLE 6 Test precision for COAT^A

Parameter	Intermediate Precision, i.p.	Reproducibility, R.
Average Engine Oil Aeration from 40 h to 50 h, %	0.672	0.872

^A These statistics are based on 39 tests conducted on three stands (one at each of three laboratories) on six ASTM TMC Reference Oils (832, PC11H, PC11I, PC11J, 833, PC11L) and were calculated on June 12, 2015.

14. Keywords

14.1 Caterpillar C13, diesel engine oil, lubricants, oil aeration; automotive; COAT; heavy-duty diesel engine.

A1. ASTM TEST MONITORING CENTER ORGANIZATION

A1.1 Nature and Functions of the ASTM Test Monitoring Center (TMC)—The TMC is a non-profit organization located in Pittsburgh, Pennsylvania and is staffed to: administer engineering studies; conduct laboratory inspections; perform statistical analyses of reference oil test data; blend, store, and ship reference oils; and provide the associated administrative functions to maintain the referencing calibration program for various lubricant tests as directed by ASTM Subcommittee D02.B0 and the TMC Executive Committee. The TMC coordinates its activities with the test sponsors, the test developers, the surveillance panels, and the testing laboratories. Contact TMC through the TMC Director at:

ASTM Test Monitoring Center
6555 Penn Avenue
Pittsburgh, PA 15206-4489
www.astmtmc.cmu.edu

A1.2 Rules of Operation of the ASTM TMC—The TMC operates in accordance with the ASTM Charter, the ASTM Bylaws, the Regulations Governing ASTM Technical Committees, the Bylaws Governing ASTM Committee D02, and the Rules and Regulations Governing the ASTM Test Monitoring System.

A1.3 Management of the ASTM TMC—The management of the Test Monitoring System is vested in the Executive Committee elected by Subcommittee D02.B0. The Executive Committee selects the TMC Director who is responsible for directing the activities of the TMC.

A1.4 Operating Income of the ASTM TMC—The TMC operating income is obtained from fees levied on the reference oils supplied and on the calibration tests conducted. Fee schedules are established by the Executive Committee and reviewed by Subcommittee D02.B0.

A2. SAFETY PRECAUTIONS

A2.1 The operation of engine tests may expose personnel and facilities to safety hazards. Personnel trained and experienced with engine testing shall perform the design, installation and operation of the test stands.

A2.2 Install guards (shields) around all external moving, hot, or cold components. Design the guard to contain the energy level of a rotating component should the component break free. Properly route fuel, oil and electrical wiring, and guard, ground and keep in good order.

A2.3 Keep the test stand free of oil and fuel spills and tripping hazards. Do not permit containers of oil or fuel, or both, to accumulate in the testing area. Fire fighting equipment shall be immediately accessible. Observe normal precautions whenever using combustible solvents for cleaning purposes.

A2.4 Safety masks, glasses or hearing protection, or a combination thereof, shall be worn by personnel working on the test stand. Do not wear loose or flowing clothing, including neither long hair nor other accessory to dress, near rotating equipment. Caution personnel against working alongside the engine and driveline while the engine is running.

A2.5 Interlocks shall automatically shut down the engine when an anomaly in any of the

following occurs: engine or dynamometer coolant temperature, engine oil pressure, dynamometer field current, engine speed, exhaust temperature, excessive vibration, or when the fire protection system is activated. The interlock shall include a method to cut off the fuel supply to the engine at the injector pipe (including the return line). A remote fuel cutoff station (external to the test stand) is recommended.

A2.6 Employ other safety precautions as required by regulations.

A3. ENGINE AND ENGINE BUILD PARTS KIT

A3.1 Obtain the Caterpillar C13 Engine Arrangement Number 244-4803 or 249-8361 by contacting the Caterpillar Oil Test Engine Representative. Current contact information is maintained at the ASTM TMC².

A3.2 Critical parts are shown in [Table A3.1](#).

TABLE A3.1 Engine Build Parts (Critical)

Item	Part Number
Piston	1Y-4106
Liner – Cylinder	1Y-4107
Ring – Top	1Y-4108
Ring – Intermediate	1Y-4109
Ring – Oil	1Y-4110
Valve – Intake	224-3028
Valve – Exhaust	224-3030
Valve Guide	259-2186
Valve Seat – Intake	224-2410
Valve Seat – Exhaust	224-1270
Connecting Rod Bearing	116-1089
Main Bearing	211-0587 and 211-0588
Thrust Plate	1Y4118 or 116-1107

Comment [HA34]: Add the two new Si-free gaskets:
Gasket, Oil Pan - 481-7229
Gasket, Rocker Cover - 481-7230

Comment [HA35]: Add a note to each of the new gaskets above so that we can add the spacers as notes. The spacers will be made available by the labs and should be made according to the Cat prints shared with TMC:
Spacer, oil pan - 489-7398
Spacer, rocker cover - 489-7397

A3.2.1 Obtain critical parts by contacting the Caterpillar Oil Test Engine Representative. Current contact information is maintained at the TMC **Error! Bookmark not defined.**

A3.3 A list of non-critical engine build parts and their current part numbers is available from the TMC. Obtain the parts directly from a Caterpillar dealer.

A4 OIL TEMPERATURE CONTROL SYSTEM

A4.1 *System Details*—See [Figs. A4.1 to A4.4](#) for details of the auxiliary oil heat exchanger setup.

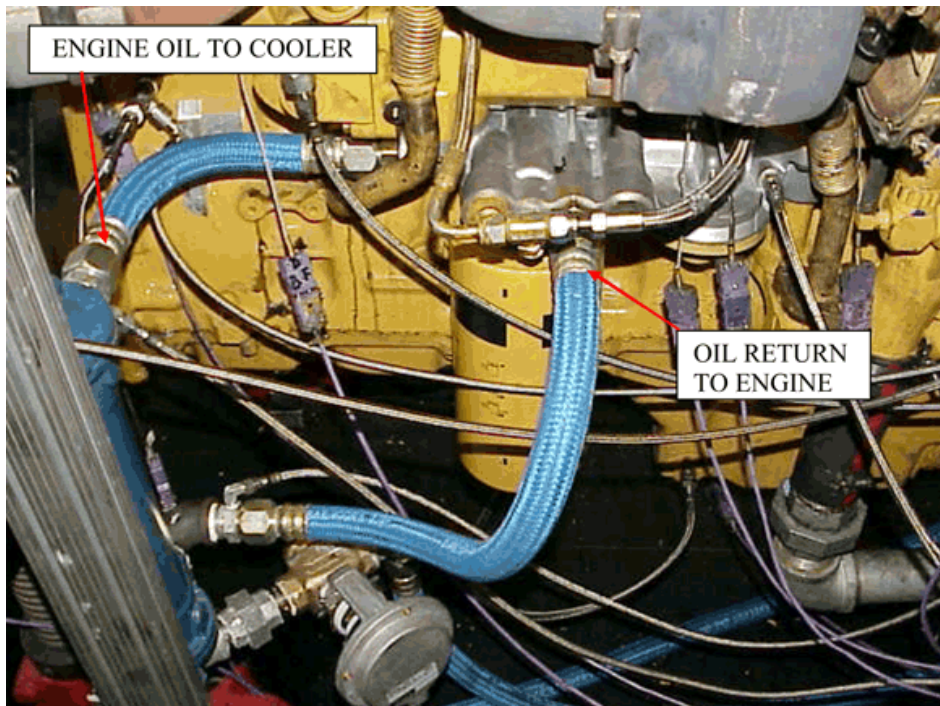

FIG. A4.1 Remote Oil Heat Exchanger

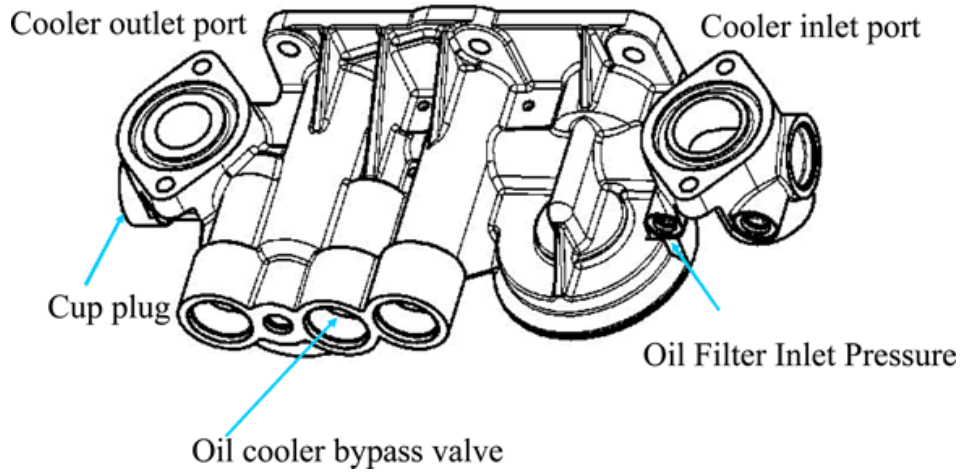

FIG. A4.2 Filter Base (P/N 251-6668) View

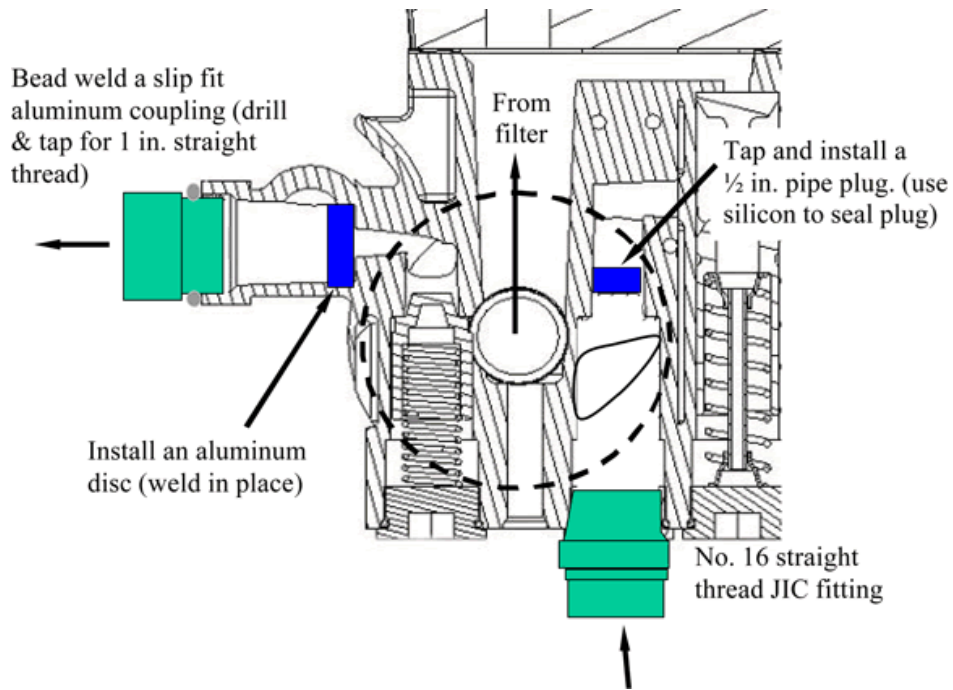

FIG. A4.3 Filter Base Modifications

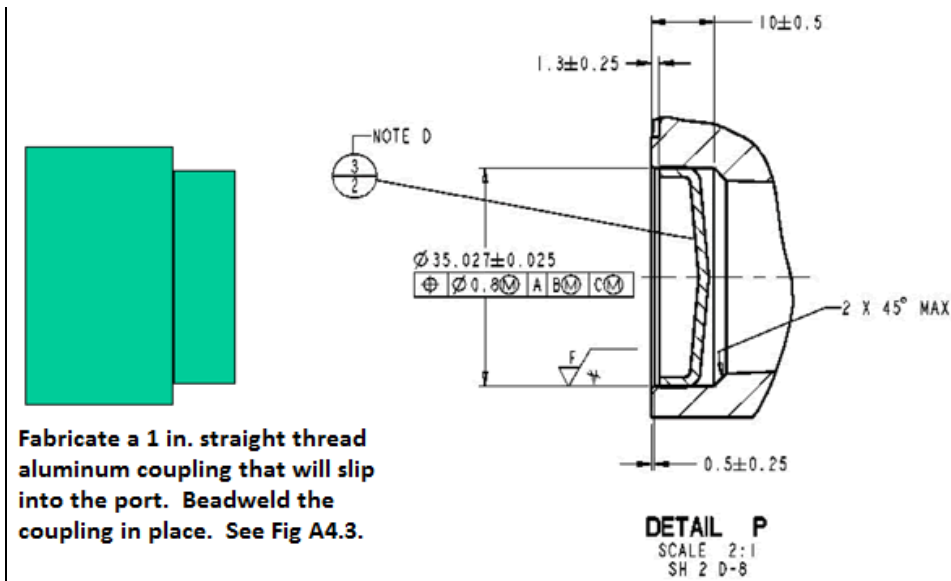

FIG. A4.4 Details of Cup Plug Feature at Back End of Filter Base

NOTE 1—Dimensions are in millimeters unless otherwise stated.

A4.2 *Heat Exchanger*—Use an ITT Standard SSCF heat exchanger, P/N SN5160030014004^{16,7}.

A4.3 *Oil Lines and Fittings* —Use two NPT size No.16 oil lines with a maximum length of 914 mm (Total of both lines), preferably made from stainless steel braided hose. Use NPT size No.16 threaded fittings for the line connections.

¹⁶ The sole source of supply of the apparatus known to the committee at this time is Standard Xchange, 176 Standard Parkway, Cheektowaga (Buffalo), NY 14227.

A5. ENGINE MODIFICATIONS AND INSTRUMENTATION

A5.1 Engine modifications and instrumentation are shown in Figs. A5.1 to A5.25.

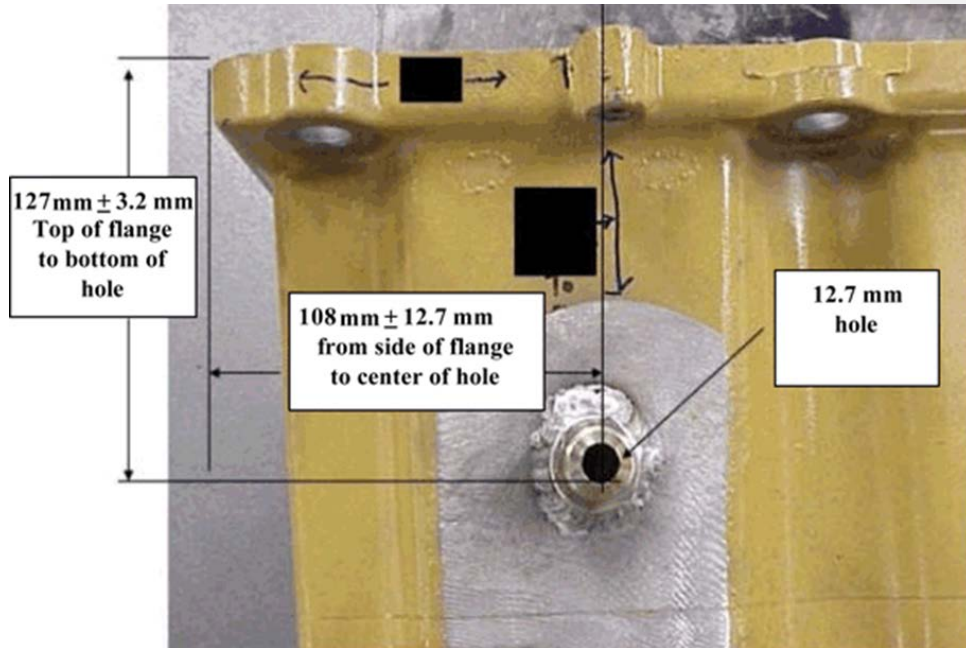
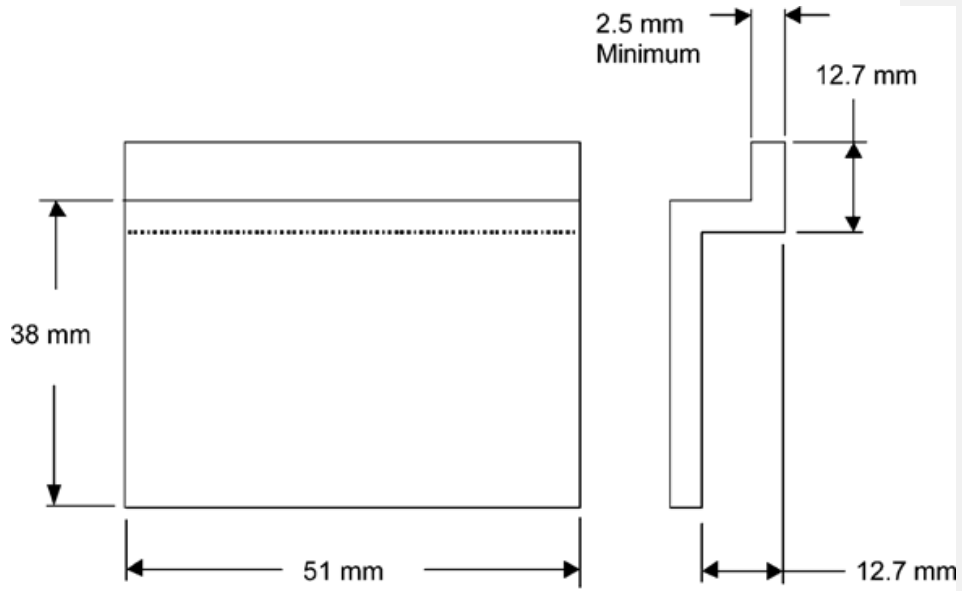

FIG. A5.1 Oil Pan Modifications for External Oil System—Auxiliary Oil System Suction Port Location (see 6.3.9.1)



NOTE 1—Bend radii to be compatible with material thickness.

FIG. A5.2 Oil Pan Modifications for External Oil System—Suction Port Baffle Design

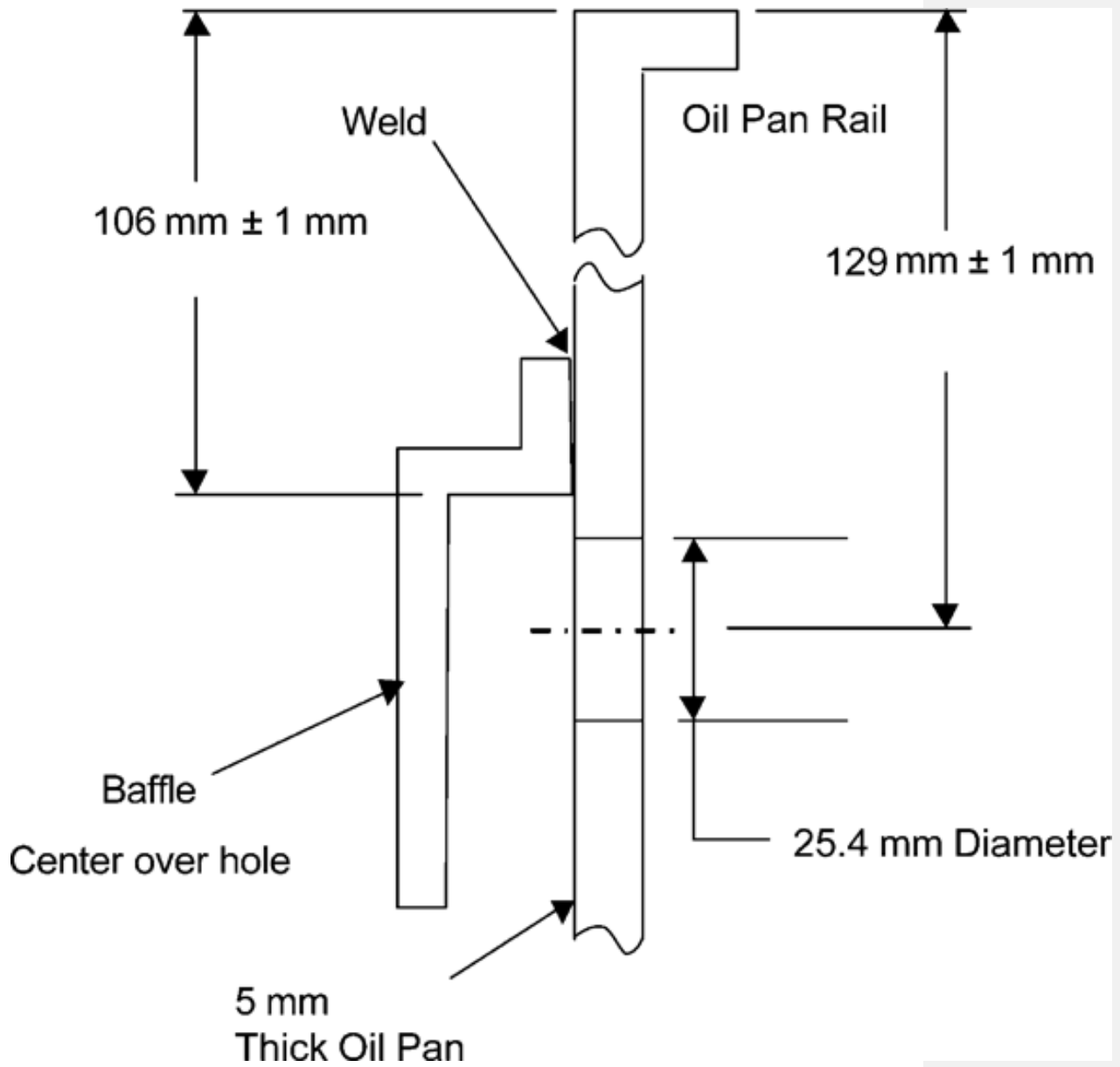

FIG. A5.3 Oil Pan Modifications for External Oil System—Baffle Placement on Oil Pan

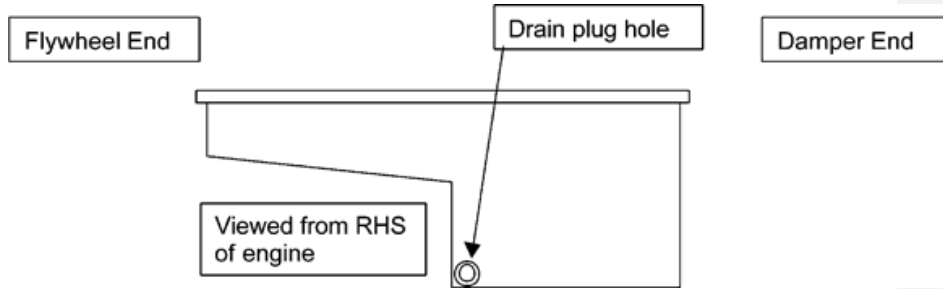

FIG. A5.4 Oil Pan Modifications for External Oil System—Auxiliary Oil System Return Port Location

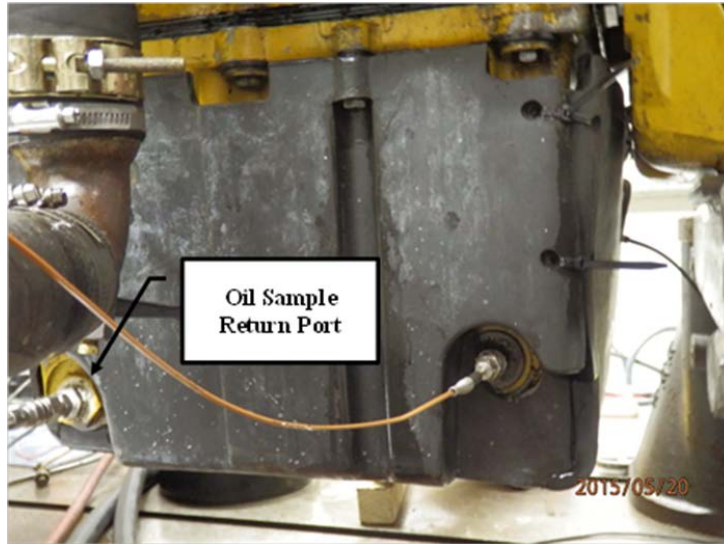

FIG. A5.5 Oil Sample Return Location

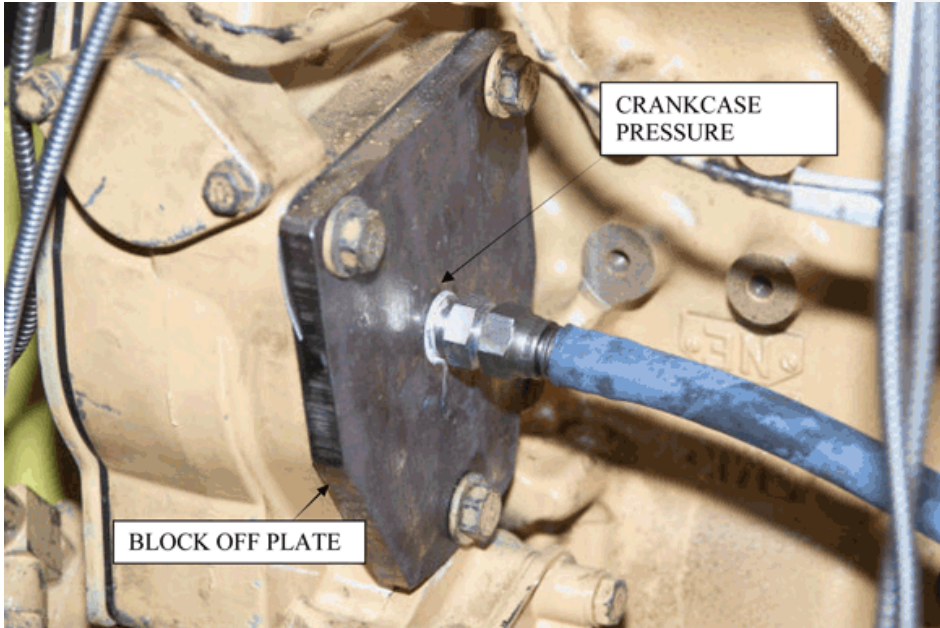

FIG. A5.6 Compressor Block-off Plate and Crankcase Pressure Balance Connection

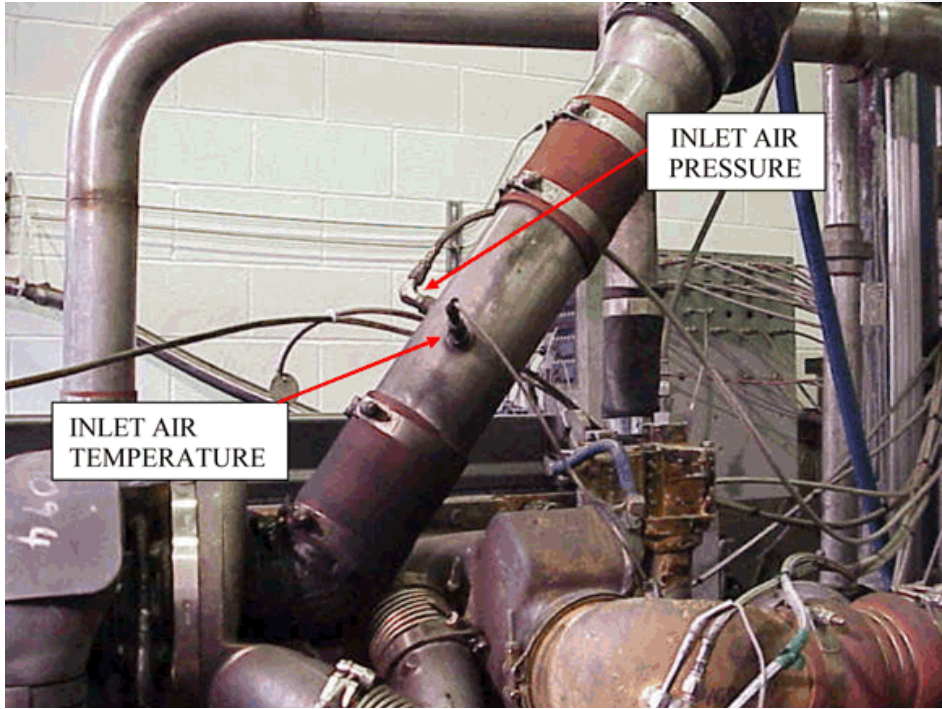

FIG. A5.7 Inlet Tube

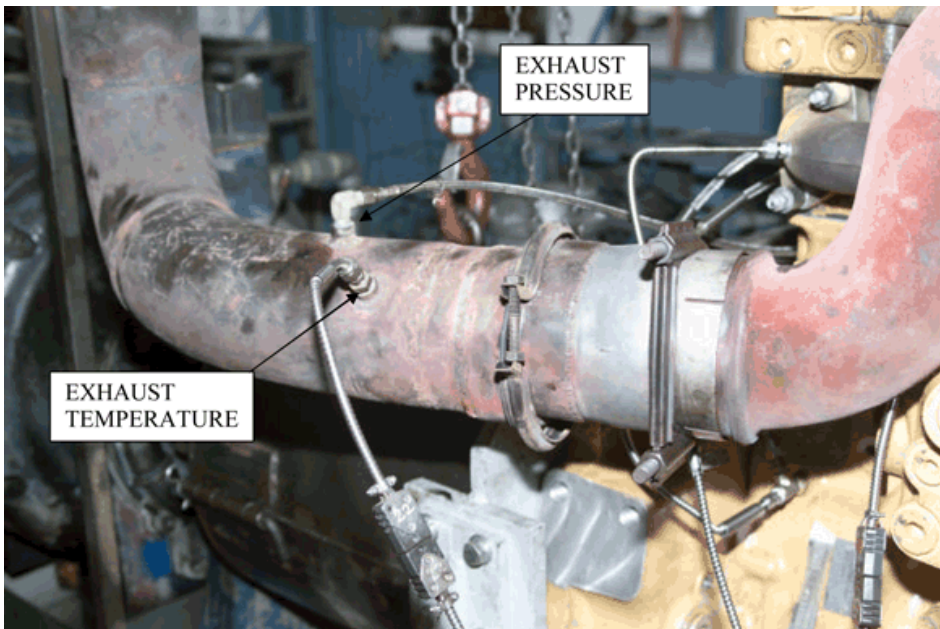

FIG. A5.8 Exhaust Tube

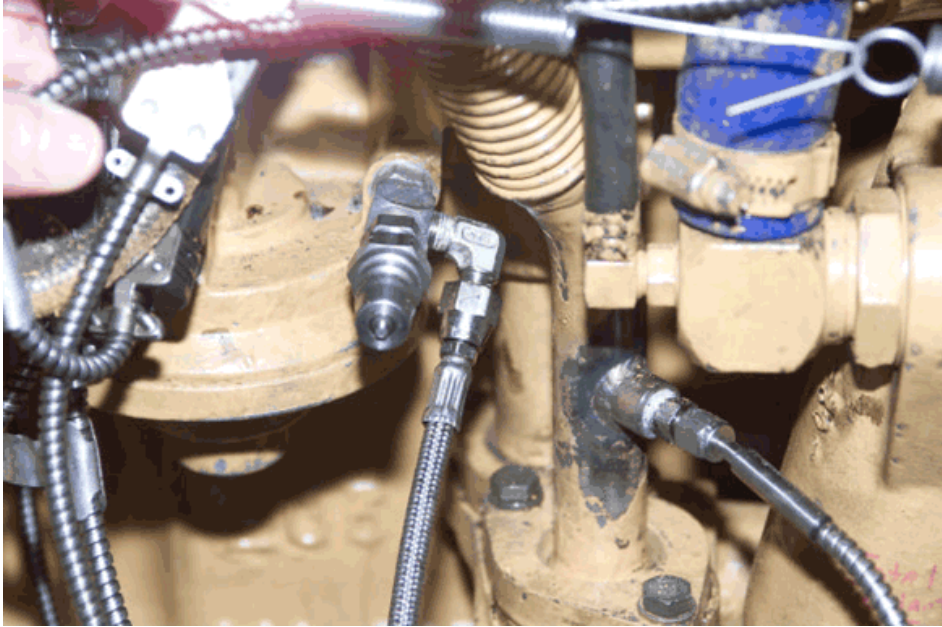

FIG. A5.9 Port for Oil Filter Inlet Pressure



FIG. A5.10 Oil Weight Cart

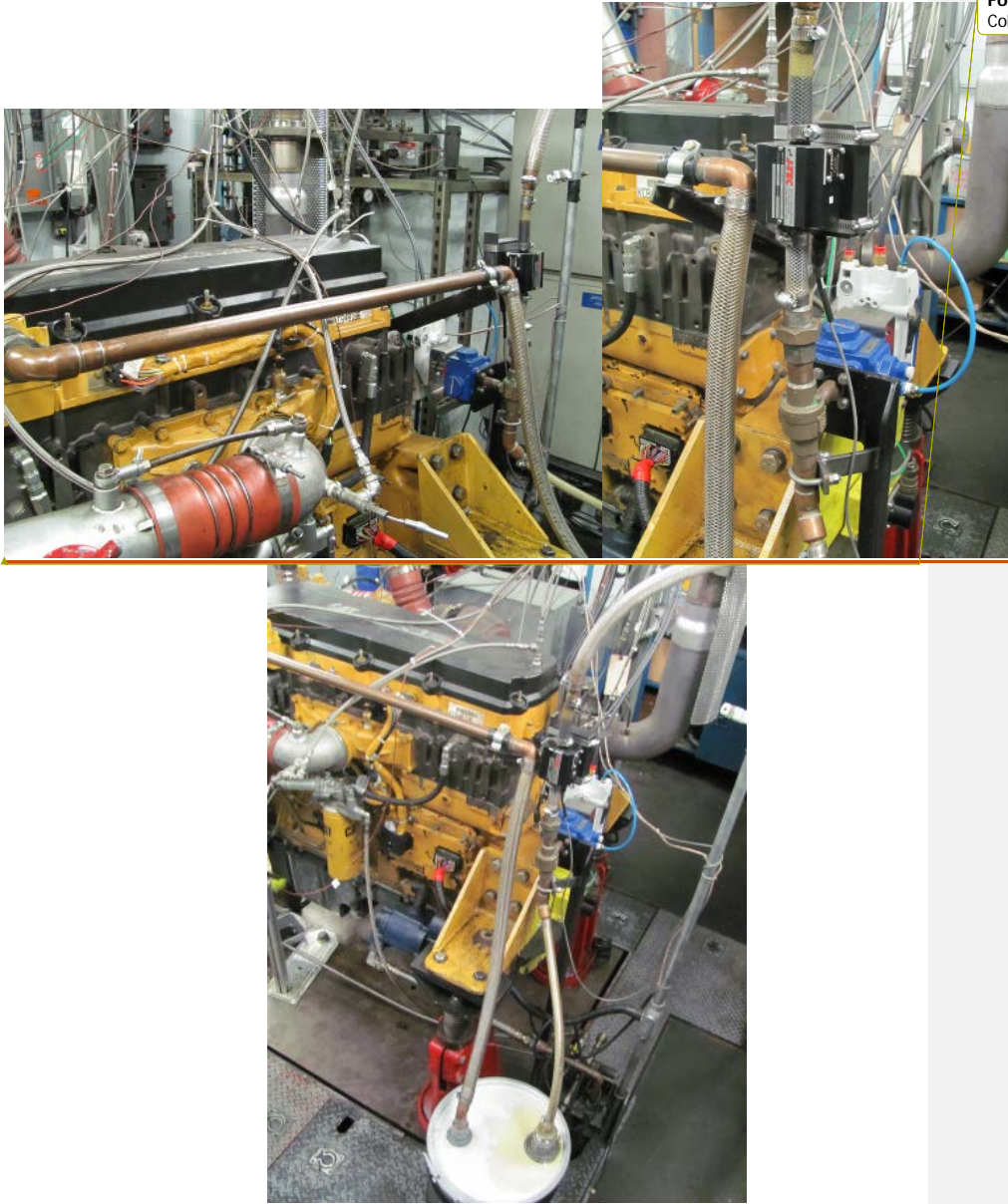

FIG. A5.11 Blowby Flow and Crankcase Pressure Control System

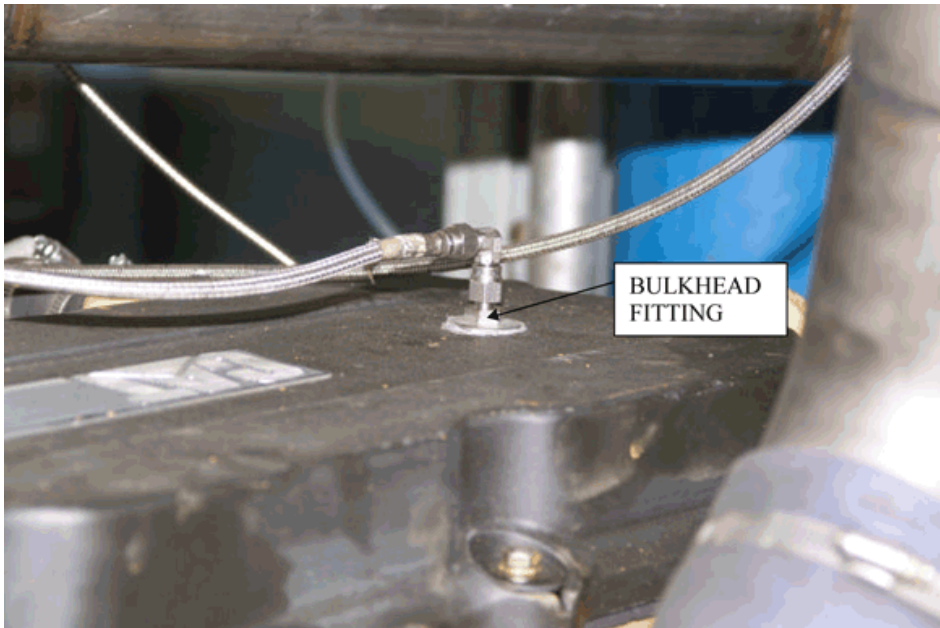

FIG. A5.12 Crankspace-Pressure Connection

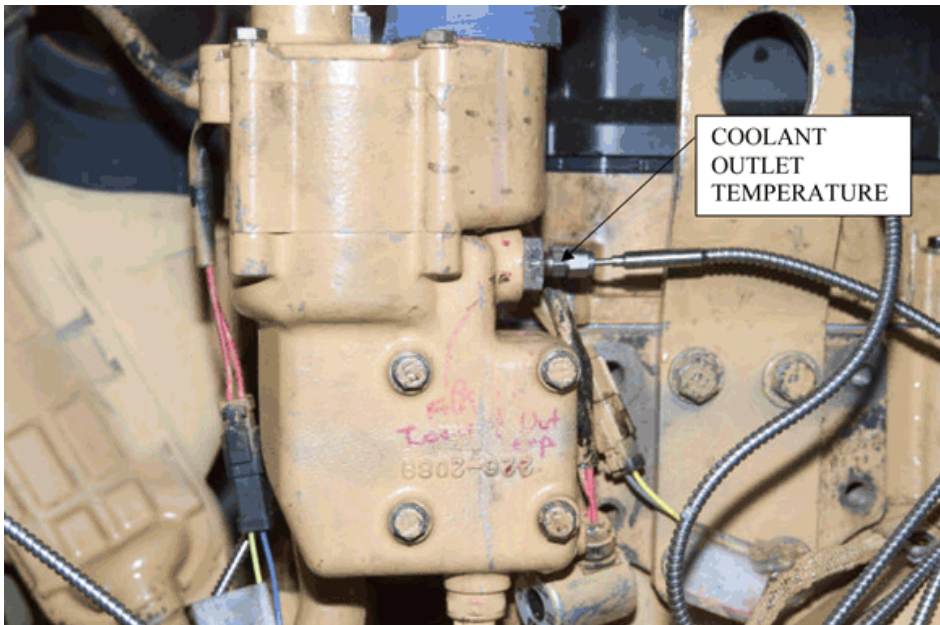

FIG. A5.13 Coolant-Outlet Temperature

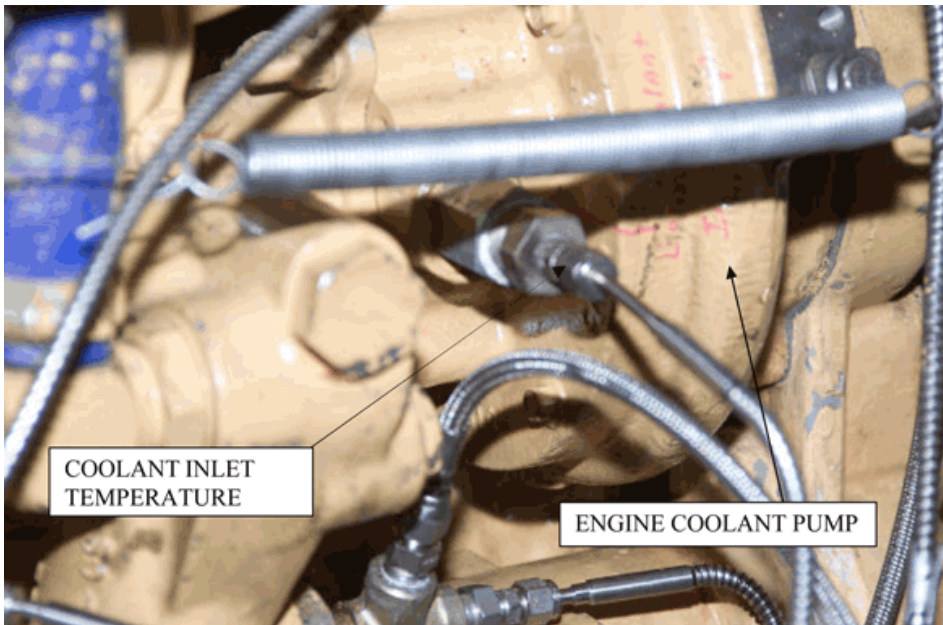

FIG. A5.14 Coolant to Engine

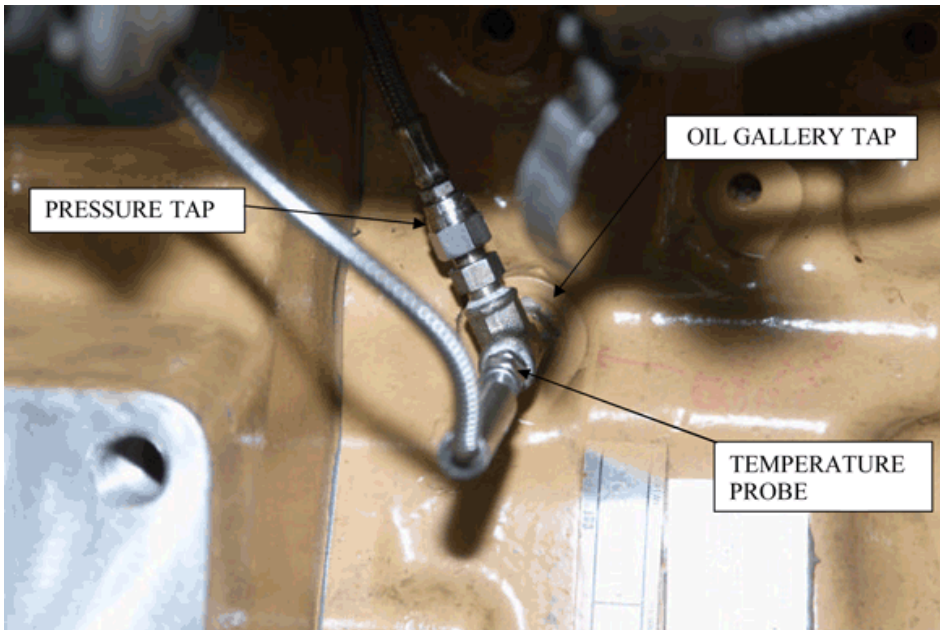

FIG. A5.15 Oil-Gallery Pressure and Temperature Measurement

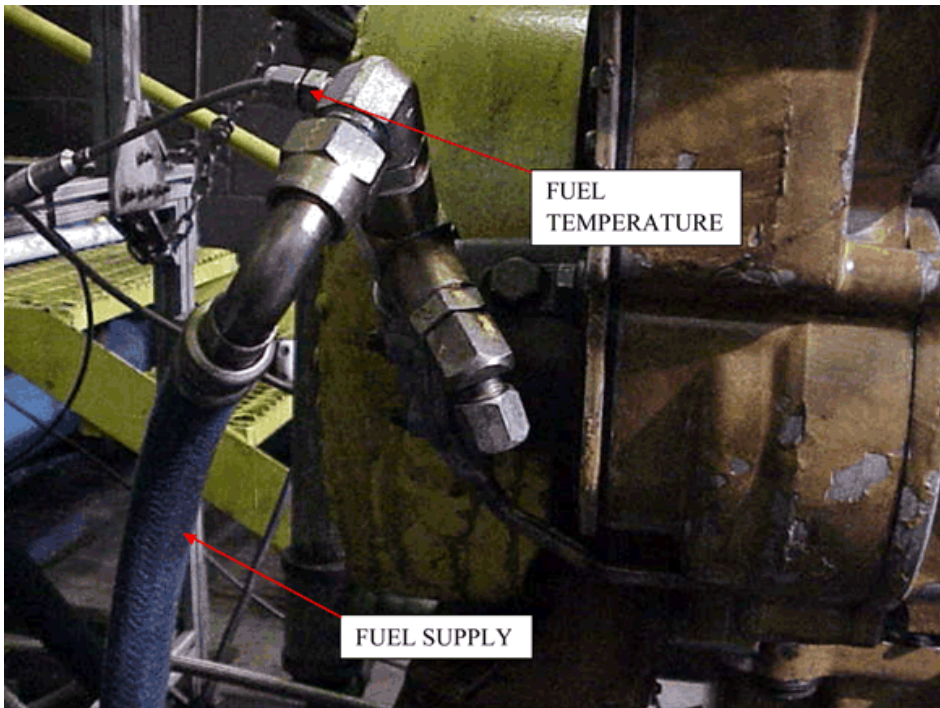

FIG. A5.16 Fuel-to-Engine Temperature Measurement

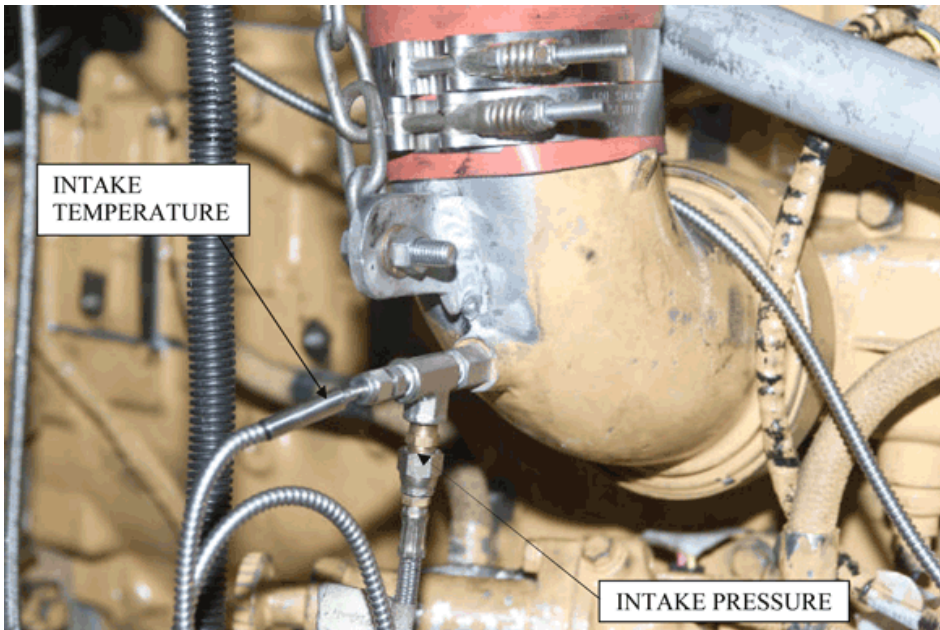

FIG. A5.17 Intake-Manifold Pressure and Temperature Measurement

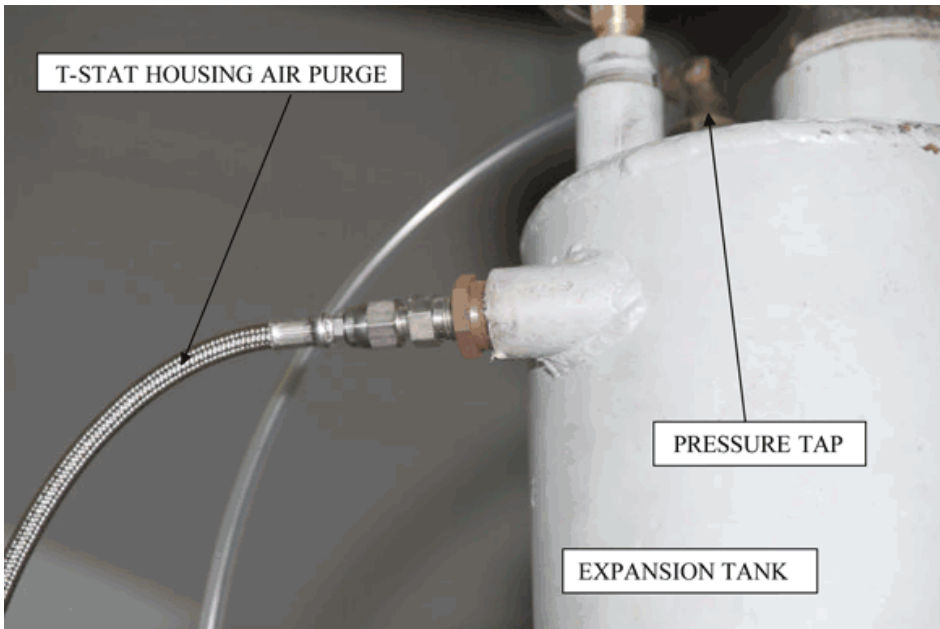

FIG. A5.18 Cooling-System Pressure Measurement



FIG. A5.19 Right-Hand Side of Installed Engine



FIG. A5.20 Left-Hand Side of Installed Engine



FIG. A5.21 Turbo-Waste-gate Control

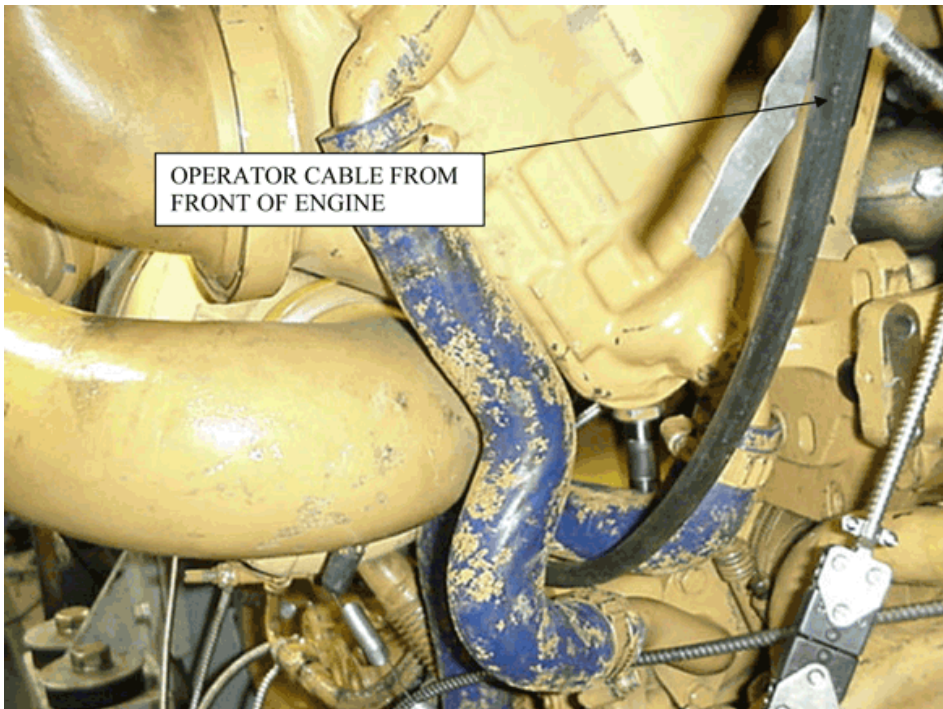

FIG. A5.22 Turbo-Waste-gate Control Cable

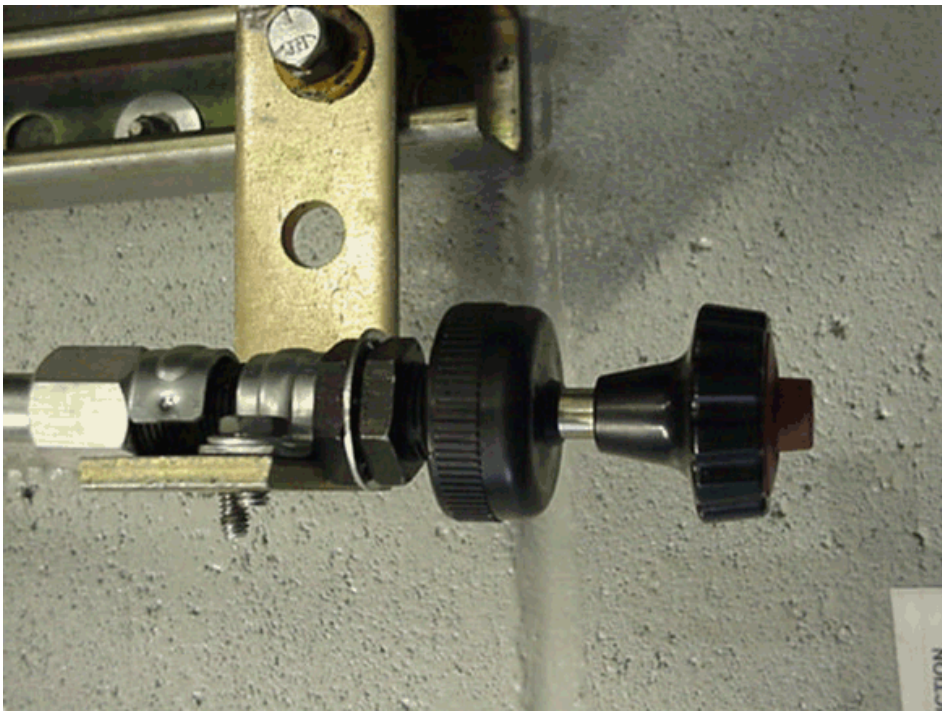

FIG. A5.23 Manual Adjuster for Turbo Waste-gate Control

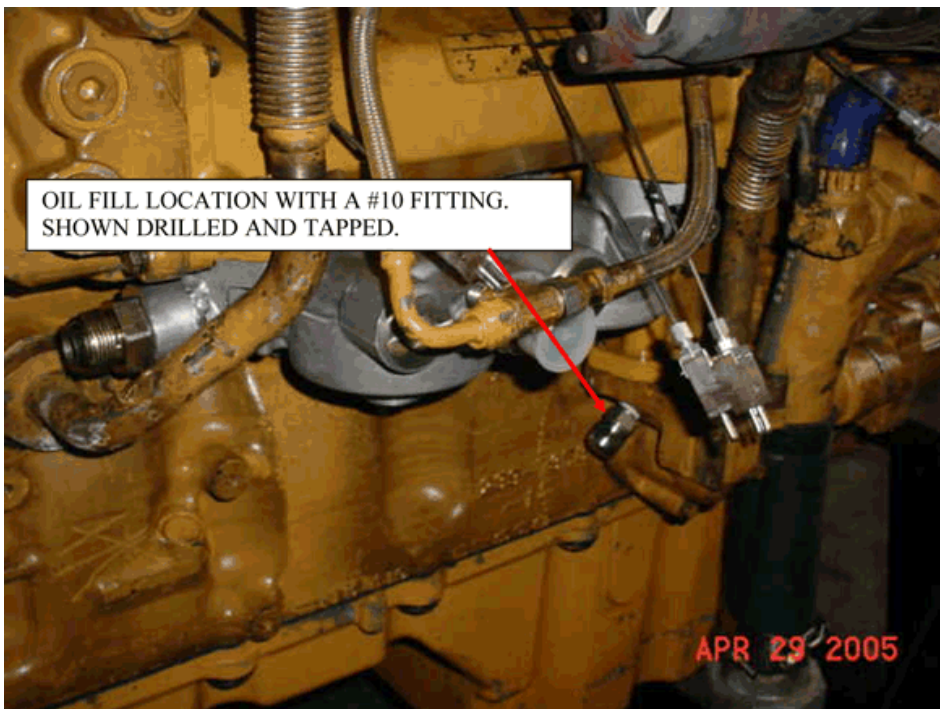

FIG. A5.24 Pressurized Oil-Fill Location



FIG. A5.25 Fuel-Pressure-Measurement Location

A6. EXTERNAL OIL SYSTEM

A6.1 See Fig. A6.1.

Hoses:

Supply - Nominal 12 mm; max length 2.7 m

Return - Nominal 10 mm; max length 2.7 m

Vent - 12 mm minimum

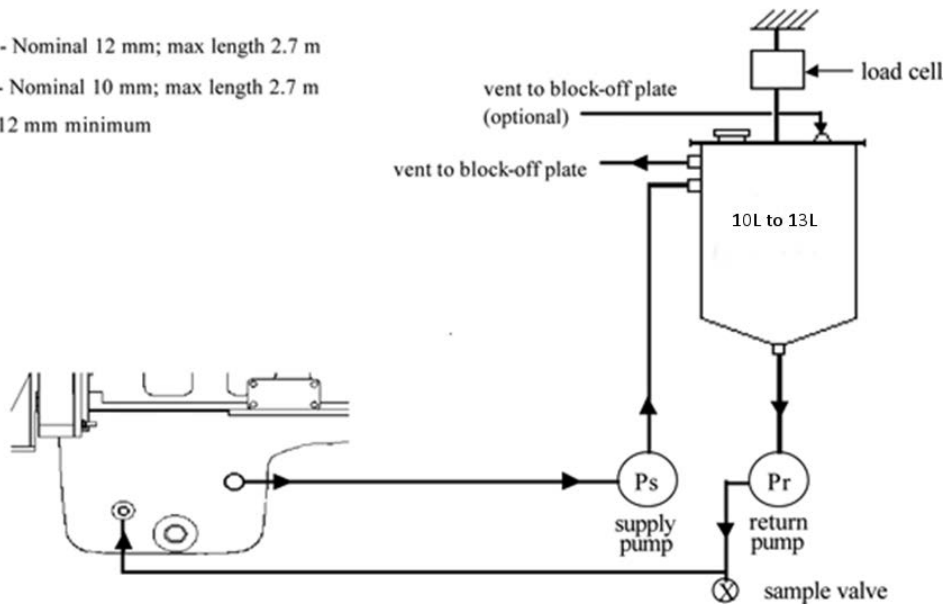

FIG. A6.1 External Oil System

A7. AERATION MEASUREMENT SYSTEM

A7.1 The general layout is shown in Figs. A7.1 and A7.2.



FIG A7.1 General Layout of the Engine and Aeration System

Comment [TB36]: Suggest we add some labels so user can identify the various components



FIG A7.2 Aeration Measurement System and Enclosure

Comment [TB37]: Suggest we add some labels so user can identify the various components

A7.2 Aeration System Piping —The following sections are numbered in the order of flow:

A7.2.1 Oil Gallery Outlet—Pull the system inlet oil from the right-hand, upper-rear gallery port using a NPT 3/8 in. straight-thread-male fitting. Connect the latter to a NPT 3/8 in. cross fitting by a NPT 3/8 in. male-to-male nipple. This cross fitting is used for gallery pressure, temperature, and the aeration oil sample flow.

A7.2.2 *Heated Line*—Connect a 5 ft x 1/2 in. heated line to the lower port of the cross fitting. See A7.2.2.1 (This is a critical part - see A7.3.1.) Bend this line to accommodate the orientations and locations shown in Fig. A7.2. See A7.2.2.2

Comment [TB38]: Can we replace 5 ft by SI equivalent, eg 1.5 m? see A.8.1.2

Comment [TB39]: Suggest we identify these "orientations and locations" in Fig A7.2

A7.2.2.1 Fittings needed to convert between pipe sizing or thread types are not defined. Select these fittings to maintain a minimum amount of additional length and as constant an internal diameter as possible.

A7.2.2.2 Take care when bending this item as it can kink or break. Use the manufacturer's recommended bend radius and methods.

Comment [HA40]: Add here something to indicate that this should not happen: "...can kink or break, which result in erroneous results."

Comment [HA41]:

A7.2.3 *Pressure Regulator*—Mount a pressure regulator to the heated line and orient it for vertical flow. This is a critical part described in A7.3.2.

A7.2.4 *FDM Inlet Line*—Run a 9.2 mm internal diameter (ID) nominal tubing line not to exceed 305 mm. in length from the outlet of the regulator. See A7.2.2.1.

A7.2.5 *4-way Coupling*—Place a 1/2 in. NPT cross fitting with the pressure line facing upwards and thermocouple fitting downwards. See A7.2.2.1.

A7.2.6 *Flow and Density Meter (FDM)*—Orient a Micro Motion Elite FDM (this is a critical part as described in A7.3.3) and a Micro Motion Elite Transmitter with the FDM inlet centerline horizontal and the unit plane vertical. See A7.2.2.1.

A7.2.7 *Mount*—Use a height-adjustable mount for mounting the FDM (9 in. ± 2 in. in from oil pan gasket to FDM centerline).

Comment [TB42]: Can we use SI units, eg, 23 cm ± 3 cm

A7.2.8 *4-way Coupling*—Place a 1/2 in. NPT cross fitting with the pressure line facing upwards and thermocouple fitting downwards. See A7.2.2.1.

A7.2.9 *FDM Outlet Line* —Run a 121.9cm. x 7 mm ID nominal tubing line from the temperature/pressure coupling to the pump. See A7.2.2.1.

A7.2.10 *Pump*—Mount the pump to the motor with the inlet centerline horizontal. This is a critical part as described in A7.3.4.

A7.2.11 *Sump Return*—Run a 121.9 cm. x 7 mm ID nominal tubing line from the pump to the right-side, rear drain plug.

A7.3 *Aeration System Critical Parts List and Sourcing:*

A7.3.1 *Heated Line*—5ft by 1/2 in. Unique Heated Products insulated and heated stainless steel line, model number SII-B-8-060-S-E8-PPO-A-AK-D72-000.^{17,7}

Comment [TB43]: Can we replace 5 ft by SI equivalent, eg 1.5 m? see A.8.1.2

¹⁷ The sole source of supply of the apparatus known to the Committee at this time is Unique Heated Products Inc., 51925 Gratiot Avenue, Chesterfield, MI 48051. www.heatedproducts.com.

A7.3.2 *Regulator*—2-way Badger Meter Research Control Valve (1/4 in., H_Trim, Air-to-Open), model number 1001GCN36SVOHLN36.^{18,7}

A7.3.3 *Flow and Density Meter (FDM)*—Micro Motion Elite, Model CMF 025, stainless steel¹⁹.

A7.3.4 *Variable Speed Pump*—Micro Motion Pump model number S-74014-40, gear pump system 115V 14.700 LBS 38^{19,7}.

A8. SPECIFIED UNITS AND FORMATS

A8.1 Specified Units:

A8.1.1 *Test Report*—Record operational parameters according to Table A8.1. Report test results in the units and with the significant digits shown in Table A8.2. Round test results in compliance with Practice E29.

TABLE A8.1 Units and precision

Parameter	Record Data to Nearest
Speed	1 r/min
Fuel Flow	1 g/min
Coolant In Temperature	0.1 °C
Coolant Out Temperature	0.1 °C
Fuel In Temperature	0.1 °C
Oil Gallery Temperature	0.1 °C
Intake Air Temperature	0.1 °C
Exhaust (Tailpipe) Temperature	1 °C
Intake Manifold Pressure	0.1 kPa
Crankcase Pressure	0.01 kPa
Exhaust Pressure	0.1 kPa

TABLE A8.2 Significant Digits for Test Results

Parameter, <u>unit</u>	Round Off to Nearest
------------------------	----------------------

¹⁸ The sole source of supply of the apparatus known to the Committee at this time is Badger Meter Inc. www.badgermeter.com.

¹⁹ The sole source of supply of the apparatus known to the Committee at this time is Emerson Process Management Micro Motion Americas, Boulder, Colorado, USA, 83010. www.emersonprocess.com.

Parameter, <u>unit</u>	Round Off to Nearest
<u>Oil Aeration, %</u>	0.01 %

A8.1.2 *Measurements and Conversions*—Except for the exceptions noted in 1.2.1, all parameters have been specified in SI units. The intent of this test method is to measure all parameters directly in SI units. If parameters are measured in inch-pound units, then the laboratory shall show to the TMC that the measurements are within the tolerances after conversion to SI units.

A8.1.2.1 Significant error may occur due to rounding or tolerance stacking, or both, when converting from inch-pound units to SI units.

A8.2 *Specification Format*—Specifications are listed in three formats: (1) target; (2) target and range; and (3) range with no target.

A8.2.1 *Target*—A target specification has no tolerance. Therefore, the only acceptable value is the target. A representative specification format is xx.xx (target). For example, the oil pan charge is listed as 30.8 kg.

A8.2.1.1 Do not intentionally calibrate or control a parameter with a target at a level other than the target.

A8.2.2 *Target and Range*—A target and a range specification implies that the correct value is the target and the range is intended as a guide for maximum acceptable variation about the mean. A representative specification format is xx.xx ± x.xx (target ± range). For example, the engine speed is 1800 r/min ± 5 r/min.

NOTE A8.1—The mean of a random sample should be equivalent to the target. Operation within the range does not imply that the parameter will not bias the final test results.

A8.2.3 *Range with No Target*—A range with no target specification is used when: (1) the parameter is not critical and control within the range is sufficient; or (2) the measurement technique is not precise, or both. A representative format is xx.xx to xx.xx (range_{low} to range_{high}). For example, the system coolant pressure is 99 kPa to 107 kPa.

A9. ASTM TMC: CALIBRATION PROCEDURES

A9.1 *Reference Oils*—These oils are formulated or selected to represent specific chemical, or performance levels, or both. They are usually supplied directly to a testing laboratory under code numbers to ensure that the laboratory is not influenced by prior knowledge of acceptable results in assessing test results. The TMC determines the specific reference oil the laboratory shall test.

A9.1.1 *Reference Oil Data Reporting* – Test laboratories that receive reference oils for stand calibration shall submit data to the TMC on every sample of reference oil they receive. If a shipment contains any missing or damaged samples, the laboratory shall notify the TMC immediately.

A9.2 *Calibration Testing:*

A9.2.1 Full-scale calibration testing shall be conducted at regular intervals. These full-scale tests are conducted using coded reference oils supplied by the TMC. It is a laboratory's responsibility to keep the on-site reference oil inventory at or above the minimum level specified by the TMC test engineers.

A9.2.2 *Test Stands Used for Non-Standard Tests*—If a non-standard test is conducted on a previously calibrated test stand, the laboratory shall conduct a reference oil test on that stand to demonstrate that it continues to be calibrated, prior to running standard tests.

A9.3 *Reference Oil Storage*—Store reference oils under cover in locations where the ambient temperature is between -10 °C and +50 °C.

A9.4 *Analysis of Reference Oil*—Unless specifically authorized by the TMC, do not analyze TMC reference oils, either physically or chemically. Do not resell ASTM reference oils or supply them to other laboratories without the approval of the TMC. The reference oils are supplied only for the intended purpose of obtaining calibration under the ASTM Test Monitoring System. Any unauthorized use is strictly forbidden. The testing laboratory tacitly agrees to use the TMC reference oils exclusively in accordance with the TMC's published Policies for Use and Analysis of ASTM Reference Oils, and to run and report the reference oil test results according to TMC guidelines. Additional policies for the use and analysis of ASTM Reference Oils are available from the TMC.

A9.5 *Conducting a Reference Oil Test*—When laboratory personnel are ready to run a reference calibration test, they shall request an oil code via the TMC website.

A9.6 *Reporting Reference Oil Test Results*—Upon completion of the reference oil test, the test laboratory transmits the data electronically to the TMC, as described in Section 12. The TMC reviews the data and contacts the laboratory engineer to report the laboratory's calibration status. All reference oil test results, whether aborted, invalidated, or successfully completed, shall be reported to the TMC.

A9.6.1 All deviations from the specified test method shall be reported.

A10. ASTM TEST MONITORING CENTER: MAINTENANCE ACTIVITIES

A10.1 *Special Reference Oil Tests*—To ensure continuous severity and precision monitoring, calibration tests are conducted periodically throughout the year. Occasionally, the majority or even all of the industry's test stands will conduct calibration tests at roughly the same time. This could result in an unacceptably large time frame when very few calibration tests are conducted. The TMC can shorten or extend calibration periods as needed to provide a consistent flow of reference oil test data. Adjustments to calibration periods are made such that laboratories incur no net loss or gain in calibration status.

A10.2 *Special Use of the Reference Oil Calibration System*—The surveillance panel has the option to use the reference oil system to evaluate changes that have potential impact on test severity and precision. This option is only taken when a program of donated tests is not feasible. The surveillance panel and the TMC shall develop a detailed plan for the test program. This plan requires all reference oil tests in the program to be completed as close to the same time as possible, so that no laboratory/stand calibration status is left pending for an excessive length of

time. In order to maintain the integrity of the reference oil monitoring system, each reference oil test is conducted so as to be interpretable for stand calibration. To facilitate the required test scheduling, the surveillance panel may direct the TMC to lengthen and shorten reference oil calibration periods within laboratories such that the laboratories incur no net loss or gain in calibration status. To ensure accurate stand, or laboratory, or both severity assessments, conduct non-reference oil tests the same as reference oil tests.

A10.3 Donated Reference Oil Test Programs—The surveillance panel is charged with maintaining effective reference oil test severity and precision monitoring. During times of new parts introductions, new or re-blended reference oil additions, and procedural revisions, it may be necessary to evaluate the possible effects on severity and precision levels. The surveillance panel may choose to conduct a program of donated reference oil tests in those laboratories participating in the monitoring system, in order to quantify the effect of a particular change on severity and precision. Typically, the surveillance panel requests its panel members to volunteer enough reference oil test results to create a robust data set. Broad laboratory participation is needed to provide a representative sampling of the industry. To ensure the quality of the data obtained, donated tests are conducted on calibrated test stands. The surveillance panel shall arrange an appropriate number of donated tests and ensure completion of the test program in a timely manner.

A10.4 Intervals Between Reference Oil Tests—Under special circumstances, such as extended downtime caused by industry-wide parts or fuel shortages, the TMC may extend the intervals between reference oil tests.

A10.5 Introducing New Reference Oils—Reference oils produce various results. When new reference oils are selected, participating laboratories will be requested to conduct their share of tests to enable the TMC to recommend industry test targets. ASTM surveillance panels require a minimum number of tests to establish the industry test targets for new reference oils.

A10.6 TMC Information Letters—Occasionally it is necessary to revise the test method, and notify the test laboratories of the change, prior to consideration of the revision by Subcommittee D02.B0. In such a case, the TMC issues an Information Letter. Information Letters are balloted semi-annually by Subcommittee D02.B0, and subsequently by D02. By this means, the Society due process procedures are applied to these Information Letters.

A10.6.1 Issuing Authority—The authority to issue an Information Letter differs according to its nature. In the case of an Information Letter concerning a part number change which does not affect test results, the TMC is authorized to issue such a letter. Long-term studies by the surveillance panel to improve the test procedure through improved operation and hardware control may result in the issuance of an Information Letter. If obvious procedural items affecting test results need immediate attention, the test sponsor and the TMC issue an Information Letter and present the background and data supporting that action to the surveillance panel for approval prior to the semiannual Subcommittee D02.B0 meeting.

A10.7 TMC Memoranda—In addition to the Information Letters, supplementary memoranda are issued. These are developed by the TMC and distributed to the appropriate surveillance panel and participating laboratories. They convey such information as batch approvals for test parts or materials, clarification of the test procedure, notes and suggestions of the collection and analysis of special data that the TMC may request, or for any other pertinent matters having no direct effect on the test performance, results, or precision and bias.

A11. ASTM TEST MONITORING CENTER: RELATED INFORMATION

A11.1 *New Laboratories*—Laboratories wishing to become part of the ASTM Test Monitoring System will be requested to conduct reference oil tests to ensure that the laboratory is using the proper testing techniques. Information concerning fees, laboratory inspection, reagents, testing practices, appropriate committee membership, and rater training can be obtained by contacting the TMC Director.

A11.2 *Information Letters: COTCO Approval*—Authority for the issuance of Information Letters was given by the committee on Technical Committee Operations in 1984, as follows: “COTCO recognizes that D02 has a unique and complex situation. The use of Information Letters is approved providing each letter contains a disclaimer to the affect that such has not obtained ASTM consensus. These Information Letters should be moved to such consensus as rapidly as possible.”

A11.3 *Precision Data*—The TMC determines the precision of test methods by analyzing results of calibration tests conducted on reference oils. Precision data are updated regularly. Current precision data can be obtained from the TMC.

A12. ENGINE BREAK-IN AND SILICON PASSIVATION PROCEDURE

A12.1 General—The purpose of this break-in is to properly stabilize engine performance by breaking-in new engine components and to passivate any engine-build silicon and fluid remnants. Such silicon can leach into the engine oil and cause elevated aeration levels.

~~A12.2 Measure oil consumption, crankcase pressure and blowby. Aeration measurement equipment is optional.~~

A12.2~~3~~ Measure the mass fraction of silicon in the fresh oil using the ICP-AES Test Method D5185.

A12.3~~4~~ Install a new Caterpillar IR-1808 oil filter.

A12.4 Charge the engine, as described in 10.2.2.1, with the Cat DEO-ULS 15W-40 oil or an equivalent Caterpillar certified CJ-4 10W-40 oil.

A12.5 *Engine Warm-up and Break-in*—Prior to firing the engine, ensure that the oil temperature is at least 15 °C. The oil gallery startup pressure shall be at least 350 kPa. Perform a timing calibration for the engine control software and timing sensor components as specified in Caterpillar Service Manual Form SEN R 9700 and Caterpillar Parts Manual C-13 On-Highway Engine, Media number SEBP3735¹⁴. If the coolant temperature is less than 18 °C, the engine will operate under cold mode thereby preventing the timing calibration procedure from being performed. When this happens, start the engine and allow it to idle until the speed drops from 1000 r/min to 600 r/min, signaling that the coolant temperature has exceeded 18 °C. After the timing calibration is completed, continue break-in conditions as shown in Table A12.1. Turn on the external oil weigh system pumps at the beginning of stage 2.

A12.5.1 At the completion of the initial 60 min break-in, shut the engine down as follows:

Comment [HA44]: Add the following (this can be added as A12.1 instead):
Use the recommended Si-free oil pan and rocker cover gaskets along with the spacers to reduce the time for Si passivation and hence to reduce the effect of Si leaching on the aeration. Part numbers of the gaskets and spacers are given in Table A3.1

Comment [TB45]: This is the warm-up and break-in from D7549, section 10.5. I have included it here for completeness and to avoid the user having to refer to another method.

Comment [TB46]: Is this correct for COAT?

[A12.5.2 Ramp in 30 s from test conditions to stage 2 of the warm-up conditions \(Table A12.2\), running for 5 min at stage 2, ramping in 30 s to stage 1, running for 5 min at stage 1, and then stopping the engine.](#)

Comment [TB47]: These are the shut down conditions in 10. 7.1 of D7549. I have included them here for completeness.

NOTE 1—[This shutdown differs from that described in 10.3.1.](#)

Comment [TB48]: Suggest we add this note (and also Notes 2 & 3) for clarification

A12.6 *Valve Lash Adjustment*—Allow the engine to cool for a minimum of 4 h and then perform the valve lash adjustment as described in Caterpillar Service Manual Form SEN R 9700 and Caterpillar Parts Manual C-13 On-Highway Engine, Media number SEBP3735¹⁴.

A12.7 *Monitoring the Amount of Silicon in the Engine:*

A12.7.1 *Engine warm-up*—Start the engine and run for 30 min under the [warm-up conditions described in Table A12.2.](#)

NOTE 2—These warm-up conditions are the same as those described in 10.6 of Test Method D7549. They differ from those described in 10.2.3 of this method.

Comment [TB49]: This is the warm-up from D7549. Suggest the table is included here to avoid having to refer to another method.it is included

A12.7.2 *Engine running hours 0 to 25*—After the end of the 30 min warm-up, proceed directly, without shutting down the engine, to the test conditions described in [Table A12.3.](#)

Comment [TB50]: These are the D7549 50 h deposit test conditions. Have included Table A12.3 for completeness.

NOTE 3—These test conditions are the same as those described in 10.6 of Test Method D7549. They differ from those described in [10.6.1](#) of this method.

A12.7.2.1 Take oil samples at 1 h and 25 h and determine the mass fraction of silicon in the oil as described in A12.2. **After 25 h:**

A12.7.3 Carry out the following steps:

A12.7.3.1 Shut the engine down [as described in A12.5.2.](#)

A12.7.3.2 Drain the oil from the engine, the oil cooler, and the oil weigh system. Remove the oil filter.

A12.7.3.3 Install a new Caterpillar IR-1808 oil filter and charge the engine, as described in 10.2.2.1, with the Cat DEO-ULS 15W-40 oil or an equivalent Caterpillar certified CJ-4 10W-40 oil.

A12.7.3.4 Start the engine, run for 30 min under the warm-up conditions described in Table A12.2.

A12.7.4 *Engine running hours 25 to 50*—Proceed directly, without stopping the engine, to the Table A12.3 test conditions.

A12.7.4.1 Take oil samples at 30 h, 40 h, and 50 h and determine the mass fraction of silicon in the oil as described in A12.2.

A12.7.4.2 **After 50 h**, shut the engine down [as described in A12.5.2](#), drain the oil, install a new filter, charge the engine with fresh oil, and run the 30 min warm up, as described in A12.7.3.

A12.7.5 *Engine running hours 50 to 75*—Proceed directly, without stopping the engine, to the Table A12.3 test conditions.

A12.7.5.1 Take oil samples at 51 h, 60 h, 70 h, and 75 h and determine the mass fraction of silicon in the oil as described in A12.2.

A12.7.5.2 **After 75 h**, shut the engine down [as described in A12.5.2](#), drain the oil, install a new filter, charge the engine with fresh oil, and run the 30 min warm up, as described in A12.7.3.

A12.7.6 *Engine running hours 75 to 85:*

A12.7.6.1—Proceed directly, without stopping the engine, to the Table A12.3 test conditions.

A12.7.6.2 Take an oil sample at 80 h and determine the mass fraction of as per A12.2.

A12.7.6.3 **After 80 h**, shut the engine down [as described in A12.5.2](#), drain the oil, install a new filter, charge the engine with fresh oil, and run the 30 min warm up, as described in A12.7.3.

A12.7.7 Proceed directly, without stopping the engine, to the Table A12.3 test conditions.

A12.7.7.1 Take an oil sample at 85 h and determine the mass fraction of silicon in the oil as A12.2.

A12.7.7.2 **After 85 h**, shut the engine down [as described in A12.5.2](#), drain the oil, install a new filter, charge the engine with fresh oil, and run the 30 min warm up, as described in A12.7.3.

NOTE 4—The mechanical break-in of the engine is completed at 85 h. All further running after 85 h, whether to passivate the engine or for the 50 h test run, is under no load conditions.

A12.7.8 *50 h Passivation run(s):*

A12.7.8.1 *General*—After the mechanical break-in has been completed, the engine is run in [segments](#) of 50 h under no-load conditions until the silicon is deemed passivated, that is, until the decrease in the mass fraction of silicon in the oil between the 1 h and 50 h samples is ≤ 3 mg/kg.

A12.7.8.2 After the end of the 30 min warm-up in A12.7.7.2, proceed directly, without shutting down the engine, to the test conditions described in Table A12.3 *but with zero load*.

NOTE 5—Because the mechanical break-in is completed at 85 h (see **Note 4**), all of the engine is under lo-load conditions.further running

A12.7.8.3 Take oil samples at 0 h, 1 h, 5 h, 25 h, and 50 h and determine the mass fraction of silicon in the oil as described in A12.2.

A12.7.8.5 After 50 h, shut the engine down, drain the oil, install a new filter, and charge the engine with fresh oil, as described in A12.7.3.1 to A12.7.3.3.

A12.7.9 Calculate the difference in mass fraction of silicon in the oil for the samples taken at 1 h and 50 h.

A12.7.9.1 If this difference is 3 mg/kg or less, proceed to the pre test procedure described in 10.2.

A12.7.9.2 If this difference exceeds 3 mg/kg, repeat A12.7.8.2 to A12.7.9 until the difference in mass fraction of silicon between the 1 h and 50 h samples is 3 mg/kg or less.

Comment [TB51]: Have added this to draw a line between the mechanical break in and subsequent no load running to passivate and for the aeration 50 h test.

Comment [TB52]: Have added this note for emphasis. Is it correct.

A12.7.10 Record the final engine hours.

TABLE A12.1 60 min. Break-in Conditions

Parameter, <u>unit</u>	Stage				
	1	2	3	4	5
Stage Length, <u>min</u>	5	5	10	20	20
Speed, <u>r/min</u>	1100	1200	1600	1800	1800 ± 5
Fuel Flow Rate, <u>g/min</u>	Record	Record	Record	Record	1200 ± 6
Torque, <u>N·m</u>	0	480	1000	1160	Record
Coolant Out Temperature ^A , <u>°C</u>	88	88	88	88	88 ± 2
Oil Gallery Temperature ^A , <u>°C</u>	Record	Record	Record	Record	98 ± 2
Intake Manifold Temperature ^A , <u>°C</u>	40	40	40	40	40 ± 2

^AThis is the control set-point. It can require up to 30 min of operation to achieve.

TABLE A12.2 Warm-up Conditions

Parameter, <u>unit</u>	Stage				
	1	2	3	4	5
Stage Length, <u>min</u>	2.5	2.5	5	10	10
Speed, <u>r/min</u>	1100	1200	1600	1800	1800
Fuel Flow Rate, <u>g/min</u>	Record	Record	Record	Record	1200
Torque, <u>N·m</u>	0	480	1000	1160	Record
Coolant Out Temperature ^A , <u>°C</u>	88	88	88	88	88
Oil Gallery Temperature ^A , <u>°C</u>	Record	Record	Record	Record	98 ± 2
Intake Manifold Temperature ^A , <u>°C</u>	40	40	40	40	40

^AThis is the control set-point. It can require up to 30 min of operation to achieve.

TABLE A12.3 Test Conditions used to Check Silicon Concentration

Parameter	Requirement
Speed, <u>r/min</u>	1800
Power, <u>kW</u>	Record
Torque (Typical) ^A , <u>N·m</u>	1760
Fuel Flow Rate, <u>g/min</u>	1200

Parameter	Requirement
Intake Manifold Temperature, <u>°C</u>	40
Blowby Flow Rate, <u>L/min</u>	Record
Coolant-Out Temperature, <u>°C</u>	88
Coolant-In Temperature, <u>°C</u>	Record
Coolant Delta Temperature, <u>°C</u>	Record
Fuel-In Temperature, <u>°C</u>	40
Oil Gallery Temperature, <u>°C</u>	98
Inlet Air Temperature, <u>°C</u>	25
Intake Manifold Pressure, <u>kPa (gage)</u>	275 to 285
Exhaust Temperature, <u>°C</u>	Record
Fuel Pressure, <u>kPa</u>	Record
Oil Gallery Pressure, <u>kPa</u>	Record
Oil Filter Delta Pressure, <u>kPa</u>	Record
Coolant System Pressure ^B , <u>kPa</u>	99-107
Exhaust Restriction, <u>kPa</u>	6
Crankcase Pressure, <u>kPa</u>	Record
Inlet Air Pressure, <u>kPa (absolute)</u>	93.0 ± 1.5
Intercooler Delta Pressure, <u>kPa</u>	15 max
Humidity, <u>g/kg</u>	Record

^A At standard atmospheric temperature and pressure.

^B As measured at the top of the expansion tank.

A13. CRITERIA FOR RECALIBRATING FDM

Comment [TB53]: We need the text for this Annex.

Comment [sam54]: I am still waiting on input from the task force. No one is willing to make a decision.

A14. SCHEDULE FOR TAKING OIL SAMPLES AND CARRYING OUT ANALYSES

A14.1 At test hours 0, 1, 5, 25 and 50 remove a 125 mL purge sample, followed by a 250 mL sample for testing. Return the 125 mL purge sample to the engine through the oil-add tube.

A14.2 Carry out the following tests on all the test samples:

A14.2.1 Kinematic Viscosity at 100 °C, mm²/s (Test Method D445)

A14.2.2 Al, Cr, Cu, Fe, Na, Pb, Si, Sn, mass fraction, mg/kg (ICP-AES Test Method D5185).

A14.3 Determine Soot by TGA Analysis, mass fraction, % (Test Method D5967, annex A4) on the 1 h, 5 h, 25 h, and 50 h samples:

A14.4 Measure Diesel Fuel Dilution, mass fraction, % (Test Method D3524) on all the test samples:

Comment [TB55]:
Please confirm this Annex is now correct.

Comment [TB56]: Please confirm TGA is required.

Comment [TB57]: Please confirm that diesel fuel dilution is carried out on all samples, not just the 50 h sample.

A15. DETERMINATION OF OPERATIONAL VALIDITY

A15.1 Quality Index Calculation

A15.1.1 Calculate Quality Index (QI) for all control parameters in accordance with the DACA II Report. Ensure missing or bad quality data are accounted for in accordance with the DACA II Report.

A15.1.2 Use the U, L, Over Range, and Under Range values shown in Table A15.1 for the QI calculations.

TABLE A15.1 Quality Index and Average Calculation Values

Control Parameter, <u>unit</u>	Quality Index Threshold	Quality Index U & L Values		Over & Under Range Values	
		U	L	High	Low
Speed, <u>r/min</u>	0.000	1802.5	1797.5	1993.6	1606.4
Coolant Out Temperature, <u>°C</u>	0.000	90.4	89.6	121.0	59.0
Inlet Air Temperature, <u>°C</u>	0.000	26.2	23.8	118.0	-68.0
Inlet Manifold Temperature, <u>°C</u>	0.000	40.5	39.5	78.7	1.3
Fuel In Temperature, <u>°C</u>	0.000	40.4	39.6	71.0	9.0
Oil Gallery Temperature, <u>°C</u>	0.000	90.2	89.8	105.5	74.5
Sample Measurement System Enclosure Temperature, <u>°C</u>	0.000	50.75	49.25	108.1	-8.1
Sample Oil Temperature, <u>°C</u>	0.000	90.2	88.8	143.7	35.3
Sample Oil Flow, <u>L/min</u>	0.000	1.53	1.47	3.8	-0.8
Sample Oil Pressure, <u>kPa (absolute)</u>	0.000	84.35	83.65	111.1	56.9
Exhaust Back Pressure, <u>kPa (absolute)</u>	0.000	104.3	103.7	127.2	80.8
Crankcase Pressure, <u>kPa (absolute)</u>	0.000	103.25	102.75	122.4	83.6
Ranged Parameter, <u>unit</u>	Range			Over & Under Range Values	
				High	Low
Inlet Air Pressure, <u>kPa (absolute)</u>	96.0 ± 1.5			212.2	0.0

Control Parameter, <u>unit</u>	Quality Index Threshold	Quality Index U & L Values		Over & Under Range Values	
		U	L	High	Low
Inlet Manifold Pressure, <u>kPa (absolute)</u>	TBD			TBD	TBD

Comment [TB58]: Please advise values.
 Sean to advise
 Comment [sam59]: Waiting on the task force

A15.1.3 Round the calculated QI values to the nearest 0.001.

A15.1.4 Report the QI values on the appropriate form.

A15.2 Averages

A15.2.1 Calculate averages for all control, ranged, and non-control parameters and report the values on the appropriate form.

A15.2.2 The averages for control and non-control parameters are not directly used to determine operational validity but they may be helpful when an engineering review is required (refer to A15.4).

A15.3 Determining Operational Validity

A15.3.1 QI threshold values for operational validity are shown in Table A15.1. Specifications for all ranged parameters are shown in Table A15.1.

A15.3.1.1 A test with EOT QI values for all control parameters equal to or above the threshold values and with averages for all ranged parameters within specifications is operationally valid, provided that no other operational deviations exist that may cause the test to be declared invalid.

A15.3.1.2 Conduct an engineering review (see A15.4) to determine the operational validity of a test with any control parameter QI value less than the threshold value.

A15.3.1.3 A test with a ranged parameter average value outside the specification is invalid.

A15.4 Engineering Review

A15.4.1 Conduct an engineering review when a control parameter QI value is below the threshold value. A typical engineering review involves investigation of the test data to determine the cause of the below threshold QI. Other affected parameters may also be included in the engineering review. This can be helpful in determining if a real control problem existed and the possible extent to which it may have impacted the test. For example, a test runs with a low QI for fuel flow. An examination of the fuel flow data may show that the fuel flow data contains several over range values. At this point, an examination of exhaust temperatures may help determine whether the instrumentation problem affected real fuel flow versus affecting only the data acquisition.

A15.4.1.1 During an engineering review, give special consideration to a deviation that might affect the oil aeration measurement for either the duration of the test or during the critical measurement period of 40 h to 50 h. For example, a negative QI generated for Sample Oil Pressure for an operational deviation that occurs during the first 10 h of the test may result in declaring the test to be valid. Conversely, the same deviation that occurs from 40 h to 50 h may result in declaring the test to be invalid.

A15.4.2 For reference oil tests, conduct the engineering review jointly with the TMC. For non-reference oil tests, optional input is available from the TMC for the engineering review.

A15.4.3 Determine operational validity based upon the engineering review and summarize the decision in the comment section on the appropriate [report](#) form. It may be helpful to include any supporting documentation at the end of the test report. The final decision regarding operational validity rests with the laboratory.

APPENDIX

(Nonmandatory Information)

X1. Typical System Configurations

X1.1 See Figs. X1.1 to X1.3.

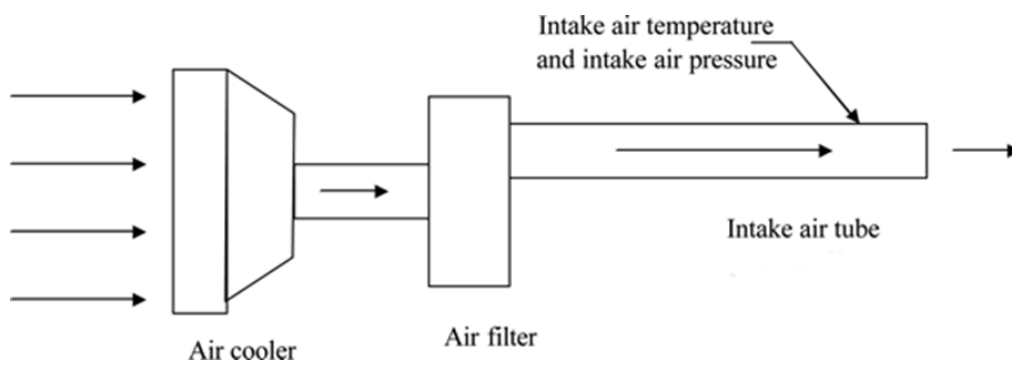

[NOTE 1—See Fig. A5.7.](#)

FIG. X1.1 Intake Air System (Typical)

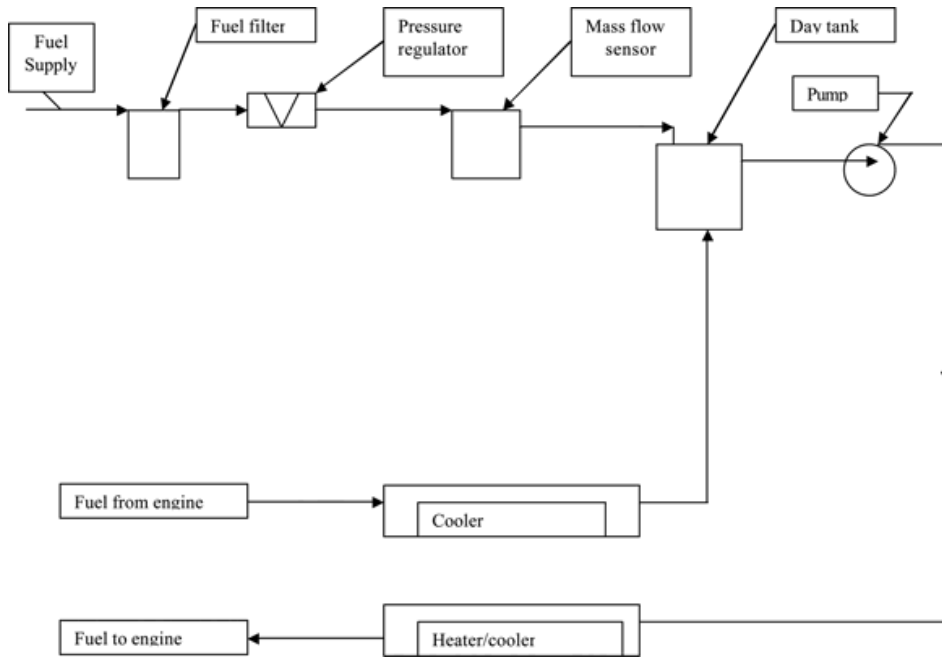

FIG. X1.2 Fuel System (Typical)

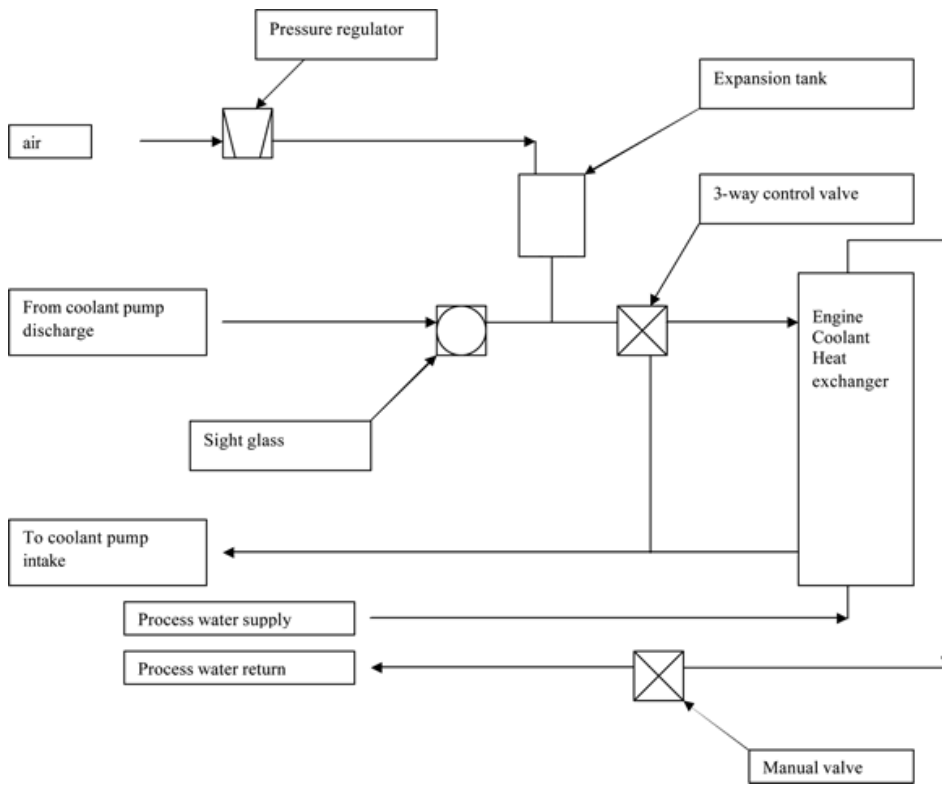

FIG. X1.3 Coolant System (Typical)